

# ESSENTIAL ALL GRAIN BREWING STARTER KIT

## THE ESSENTIAL ALL GRAIN BREWING STARTER KIT CONTAINS:

### MASH/LAUTER TUN

- 7 or 10 gallon Fermenter's Favorites™ Cooler
- 10" or 12" stainless false bottom
- Cooler valve and bulkhead
- 2, 1/2" MPT to 3/8" barbed fittings
- 3.5 feet of 3/8" ID high-temp tubing (clear)

### SPARGE WATER TANK

- 7 or 10 Fermenter's Favorites™ Cooler
- Cooler valve and bulkhead
- 1/2" MPT to 3/8" barbed fitting
- 3.5 feet of 3/8" ID thermoplastic tubing (beige)
- Siphon sprayer



## SETUP

### CLEANING

Rinse and sanitize all components before they come into contact with wort or brewing water. After the initial use, it will not be necessary to sanitize mashing equipment before use as long as it is surface-clean.

### ASSEMBLE THE MASH/LAUTER TUN

1. Insert the false bottom, elbow up, in the cooler. Thread the 1/2" MPT to 3/8" barbed fitting into the FPT port of the cooler bulkhead (the side that will be inside the cooler).
2. Install the cooler bulkhead and valve assembly as specified in the cooler conversion instructions.
3. Connect the barbed elbow fitting on the false bottom to the barbed fitting on the bulkhead using a few inches of 3/8" ID thermoplastic tubing.

### ASSEMBLE THE SPARGE WATER TANK

1. Install the cooler bulkhead and valve assembly as specified in the cooler conversion instructions.
2. Attach one end of a 3.5-foot section of 3/8" ID thermoplastic tubing to the sprayer; the other end of the tubing will connect to the barb on the ball valve on the outside of the tank.

## CONNECTING & TESTING

1. Get set up. Your All-grain system is powered by gravity. The sparge water tank will need to be the highest point of your system, with the boiling kettle the lowest point. The mash/lauter tun will need to be in between. Place the sparge water tank (SWT) on a table or counter; place the mash/lauter tun (MLT) on a chair or stool beneath it. The boiling kettle will rest on the floor beneath the MLT to collect the wort.
2. Connect the tubing with the sprayer to the sparge water tank valve. Let the sprayer hang several inches down into the mash/lauter tun.
3. Attach the remaining length of tubing to the mash/lauter tun valve, and let the free end hang inside the boiling kettle.
4. Close the valves on both vessels. Fill the sparge water tank with a couple gallons of water.
5. Open the valve on the sparge water tank – the sprayer should deliver a gentle drizzle of water to the mash/lauter tun (you can adjust the flow rate using the valve on the sparge water tank).
6. When a few inches of water have collected in the mash/lauter tun, open the MLT valve. You should be able to easily adjust the flow of the water going into the boiling kettle.

## GETTING READY TO BREW

This battle station is operational, commander. Please read through the entire mashing and sparging instructions before starting to brew! And remember – be careful! All-grain brewing involves working with heavy vessels full of very hot liquids.

# MASHING AND SPARGING

## CRASH COURSE IN MASHING

The information below is for a single-step infusion mash. This is the simplest mash schedule and is used extensively in ale brewing.

### PROCEDURE

**COLLECT THE STRIKE WATER.** You will need 1.3 quarts of water for every pound of grain to be mashed.

**HEAT THE STRIKE WATER TO 175° F.** Pour the heated water into the mash tun. Slowly add the grist (crushed grain) to the water in the mash tun. Stir well to prevent clumping. The temperature should stabilize at 154° F. Hot or cold water can be added to correct the temperature, but a 5° variation is fine. **DO NOT EXCEED 168° F DURING THIS STEP**, or you may destroy the enzymes needed for starch conversion.

- **NOTE** – if you are following an all-grain recipe, use the mash temperature specified in the recipe, and adjust the strike water temperature accordingly.

**REST AT THIS TEMPERATURE FOR 60 MINUTES.** During this saccharification rest, malt enzymes convert the grain's starch into fermentable sugars.

**WHILE THE MASH IS RESTING, COLLECT SPARGE WATER.** You will need 1/2 gallon of sparge water per pound of dry grist in the recipe. Heat the sparge water to 175° F

**MASH-OUT BY RAISING THE TEMPERATURE TO 168-170° F.** Add very hot (200° F) water to the mash, stirring constantly. Do not allow the mash temperature to exceed 170° F as hot temperatures can leach harsh-tasting tannins from the grain.

**REST AT THIS TEMPERATURE FOR 5-15 MINUTES.**

- **NOTE** - The main benefit of mashing-out is to raise the temperature of the mash in preparation for sparging, or the rinsing of sugars out of the mash. If the temperature of the mash gets too cold, the sugars will gum up making it exceedingly difficult for water to flow through the grain bed. Mashing-out also destroys the enzymes in the mash, preventing any additional starch conversion.

**AT 170° F TRANSFER THE SPARGE WATER.** Move water to the sparge water tank and continue with the procedure for sparging given below.

### PRINCIPLES AND ADVICE

At a mash temperature range of 150° to 158°F, enzymes in the malt activate and convert complex starches to simple sugar molecules that are fermentable.

Avoid temperatures greater than 168° F until you are ready to mash-out, or finish the mashing process. If you measure temperatures greater than 168°F in your mash, quickly cool the mash by adding cold water.

If you undershoot the target mash temperature by more than 5° F you may raise the mash temperature by adding heat. Stir the mash constantly while you are applying heat.

In order to increase the accuracy at which you hit mash temperatures, it is absolutely essential that you take good notes. At a minimum, you should log the time and temperature before and after every significant heat input.

## CRASH COURSE IN SPARGING

### PROCEDURE

**RECIRCULATE!** The initial runoff from the lauter tun is cloudy and filled with draff - small solid grain particles. The runoff should be clarified by recirculating the runoff through the grain in the lauter tun. To recirculate, open the valve on the lauter tun slightly and collect the runoff in an intermediate vessel(s) – two 1 quart measuring cups or pitchers work well. Fill one vessel and pour it gently down the side of the lauter tun. While you are pouring the wort back into the lauter tun fill the other vessel. Switch back and forth, filling and dumping, until the wort appears clear. At this point the wort can be drained into the boiling kettle. Make sure you keep the grain bed wet during the recirculation. Usually, after 5-15 minutes of recirculation, clarity improves dramatically.

**SPARGING.** Open the valve on the sparge water tank to gently disperse the 170° F sparge water over the top of the grain bed. As in recirculating, do not allow the grain bed to go dry until sparging is complete. Avoid sparge water temperatures in excess of 175° F, as this promotes the extraction of tannins from the grain and leads to a harsh, astringent flavor in the finished beer. Stop sparging once you have collected an adequate amount of wort, or when the runoff reaches a specific gravity of 1.008-1.012.

**MOVE THE KETTLE TO A BURNER.** When the sparge is finished and the wort collected, (it's very heavy and hot - be careful!) move the kettle and proceed with the boil. Clean the mash/lauter tun and thoroughly rinse it with hot water; store components dry to keep them ready for the next brewing day!

### PRINCIPLES AND ADVICE

The process of separating the newly created wort from the mash is called sparging or lautering. The objectives of sparging are to collect as much sugar from the mash as possible while leaving behind as many undesirable compounds as possible.

Sparging is conducted in a specialized container called a lauter tun. A lauter tun is essentially a strainer. Wort collects in the foundation space beneath the false bottom and exits through the valve, where it collects in the boiling kettle.

### A NOTE ON STUCK MASHES

A stuck mash occurs when the runnings from the lauter tun slow to a trickle and stop because the filter bed of husks has clogged. This may be caused by crushing the grain too fine, putting too much sparge water on the grain bed, losing too much heat in the lauter tun, and/or using glutinous adjuncts like wheat, oats or unmalted barley. Running wort off too quickly can compact the grain bed and exacerbate the problem.

To remedy a stuck mash, close the valve and stop adding sparge water. Gently stir the bed up into suspension (adding a bit of sparge water may help a thick bed). Slowly begin to draw wort off, repeating the recirculation step before recollecting wort. In extreme instances you may have to remove the mash, clean the lauter tun, put the mash back in the lauter tun, reheat the mash to 168° F and start over.

**FERMENTER'S FAVORITE**

# **STAINLESS FALSE BOTTOM**

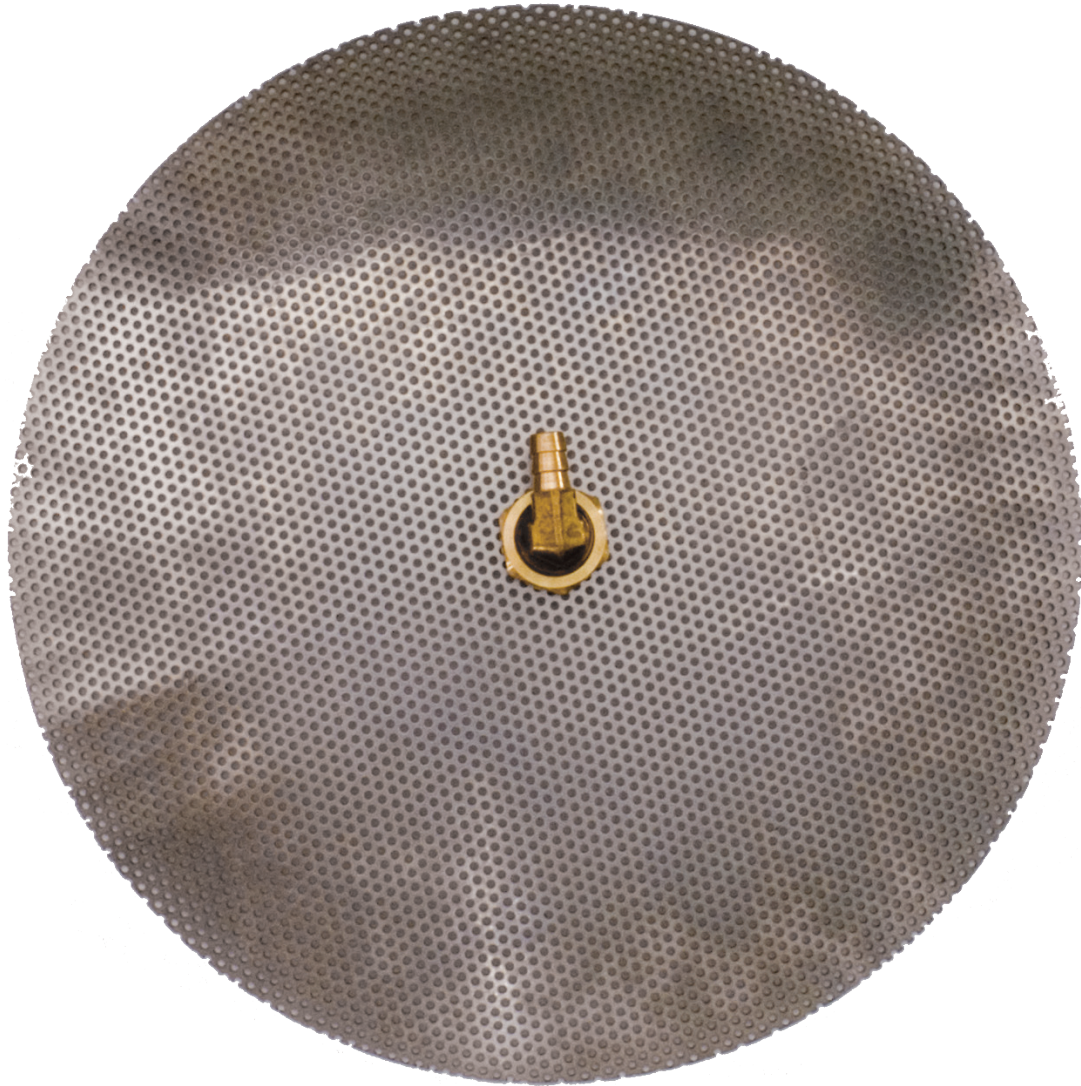

## **BEFORE USE**

Hand-wash the false bottom with a mild dishwashing detergent to remove any oil from the manufacturing process. Rinse thoroughly with warm water.

## **CARE AND MAINTENANCE**

Wash with hot water after every use; store dry. It should not be necessary to remove the false bottom after each use.

## **INSTALLATION**

**FOLLOW THESE STEPS TO INSTALL A STAINLESS FALSE BOTTOM IN A 7 OR 10 GALLON FERMENTER'S FAVORITES™ MASH/LAUTER TUN.**

1. Insert the false bottom, elbow up, in the cooler.
2. Install the bulkhead and/or valve assembly as specified in the conversion kit's instructions.
3. Connect the barbed elbow fitting to the barbed fitting on the bulkhead using a few inches of  $\frac{3}{8}$ " ID high-temp tubing.



# VALVE & BULKHEAD ASSEMBLY FOR COOLERS

1. Begin by disassembling the valve and bulkhead assembly. Separate the coupler, steel washer, and both silicone O-rings. This will leave you with only the nipple and locknut to remove from the valve.

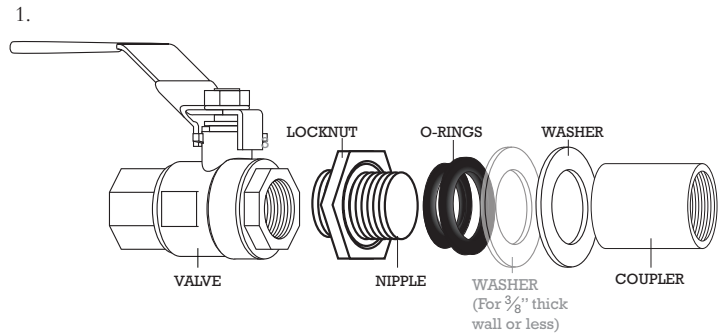

2. Ensure the locknut is threaded on to the nipple as far as it will go. Apply 3 wraps of thread tape to the nipple (on the side where fewer threads are showing), and then thread into the ball valve.

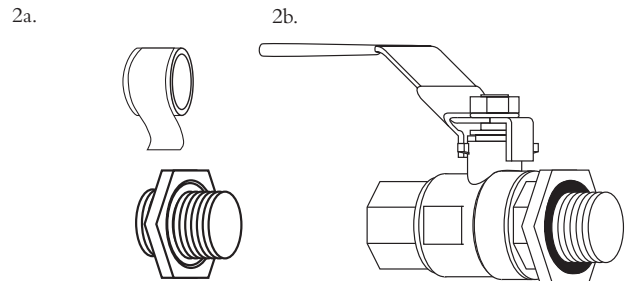

3. Place the small O-ring on the nipple and push it all the way into the groove of the locknut, then insert the assembly through the hole in the cooler. The O-ring should be resting on the outside of the cooler.

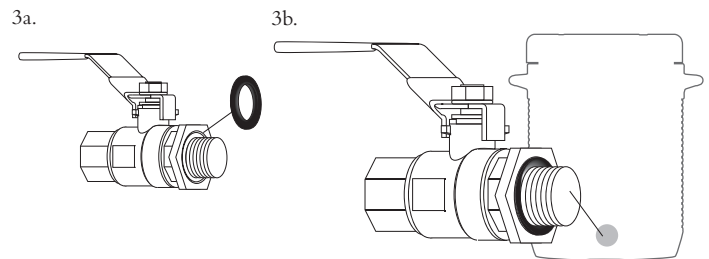

4. On the inside of the cooler, place the large O-ring on the nipple and push it against the inside wall of the cooler.

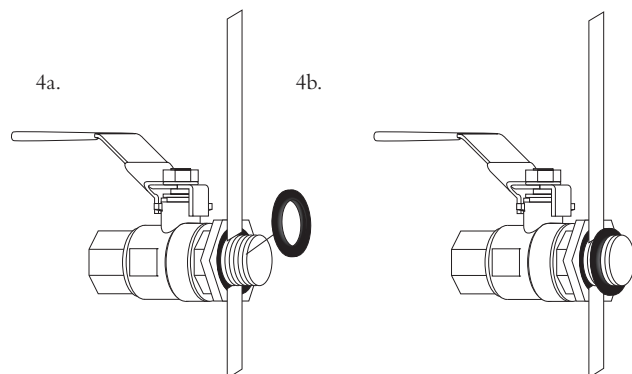

5. Slide the Washer(s) onto the nipple, then thread on the coupler. Hand tighten the coupler until snug, then tighten further by holding the coupler in place and rotating the valve until hand tight.

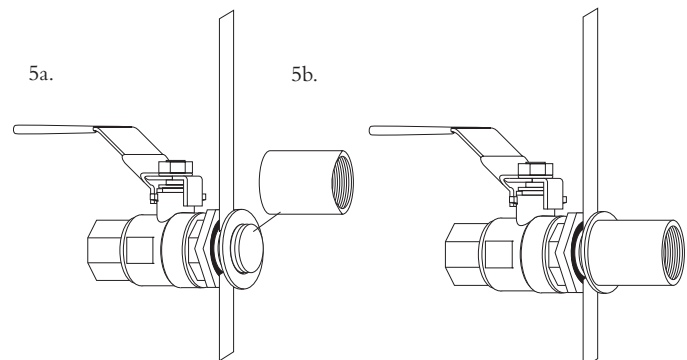

**PRO TIP**

Fill with water to leak test. If leaking from the O-rings next to the cooler wall, ensure that the O-rings are properly seated and try slightly tightening the locknut. If leaking from the ball valve, remove and apply more thread tape.

# STEP INFUSION MASHING

THESE INSTRUCTIONS ASSUME FAMILIARITY WITH ALL-GRAIN BREWING USING A SINGLE INFUSION MASH.

## PROCEDURE

**1. COLLECT THE STRIKE WATER** - you will need 1 qt. of water for every pound of grain to be mashed (more water will be needed if there is a large foundation space, empty space between the false bottom and the bottom of the mash vessel). In a kettle, heat the strike water to 134°F. Pour the heated water into the mash tun. Slowly add the grist (crushed grain) to the water in the mash tun, stirring well to prevent clumping. The temperature should stabilize at 122°F. Proteolytic enzymes are active from 113° to 131°F. Do not exceed 150°F during this step, or you may destroy the enzymes needed for protein breakdown.

**2. REST AT THIS TEMPERATURE FOR 20 TO 30 MINUTES.** During the protein rest, malt enzymes break up large protein molecules to improve head retention and body and reduce haze.

**3. WHILE THE MASH IS RESTING, COLLECT THE INFUSION WATER** - you will need 0.5 to 0.75 qt. of water for every pound of grain used in the mash. In a kettle, heat the infusion water to 200°F.

**4. ADD HOT WATER.** When the protein rest is finished, add the hot infusion water, 1 qt. at a time, to the mash to raise the temperature to the saccharification range. Stir and measure the temperature after each addition. The temperature should stabilize between 149° and 158°F - refer to your recipe for the exact saccharification rest temperature to be used. Do not exceed 168°F during this step, or you may destroy the enzymes needed for starch conversion.

**5. REST AT THIS TEMPERATURE FOR 60 MINUTES.** During the saccharification rest malt enzymes convert the grain's starch into fermentable sugars.

**6. COLLECT AND HEAT SPARGE WATER.** While the mash is resting, collect and heat sparge water. When the saccharification rest is finished, proceed sparging as with an infusion mash.

**NOTE:** You may proceed with a mash-out (brief rest at 168°-170°F) before sparging, but this may require a large amount of boiling water to reach desired temperature.

## PRINCIPLES AND ADVICE

What makes a multiple-step infusion mash different from a single-step infusion mash is the inclusion of a protein rest of 20-30 minutes at or near 122°F. The purpose of a protein rest is to use proteolytic enzymes within the grain to break down large protein molecules in the mash, which achieves four important things:

- Reduces protein haze when the beer is chilled
- Reduces body and head retention by creating small molecular-weight proteins which remain in the beer
- more thoroughly releases starch from grain's endosperm, giving higher mash yields
- Creates a nutrient-rich wort for yeast

A protein rest is used when brewing with low or moderately-modified malts, or high-protein grains like wheat or corn. Modification refers to the degree of protein breakdown that is carried out during malting. Low- or moderately-modified malts are often made from high-nitrogen barley; these kinds of malts are usually for lager brewing and are made from barley grown in continental Europe, especially Germany and the Czech Republic.

- **NOTE:** Since English and American malts are fully modified, the proteolytic enzymes have already been used and destroyed during malting, so there is no benefit from including a protein rest when brewing with these malts.

## MULTIPLE STEP INFUSIONS

The keys to multiple-step infusion mashing are raising the temperature of the mash evenly and preventing heat loss during the rests. As with a single-infusion mash, a multiple-step infusion begins when water is heated to a given strike temperature, then mixed with the grist to reach the protein rest. After a 20 to 30 minute protein rest, the temperature of the mash is raised to the saccharification range, where it rests for 60 minutes at 150° to 158°F. From this point onward, the procedure for a multiple-step infusion mash is the same as for a single-step infusion.

Adding infusions of hot water to the mash to raise the temperature is the most common method; remember to stir thoroughly. This method allows you to mash in an insulated vessel like a picnic cooler, which minimizes heat loss. If you mash in a kettle, you can apply direct heat to raise the temperature of the mash. It is important to start with a more dilute mash and stir constantly when direct-heating your mash. The drawbacks to this method are the risk of scorching the mash and the risk of destroying the enzymes with uneven heat.

# DECOCTION MASHING

The steps below describe the procedure for conducting a double decoction mash, a traditional European technique still used today by many Czech and German breweries. These instructions assume familiarity with all grain brewing using a multiple-step infusion mash.

## TO CONDUCT A DECOCTION MASH, YOU WILL NEED:

(in addition to a mash/lauter tun and other standard all-grain equipment)

- a small kettle (at least 3 gallons) for boiling the decoctions.
- A 1 qt. measuring cup with a handle or a small strainer is ideal for separating the thick mash.
- a well-insulated mash tun to prevent heat loss. Decoction mashes take longer than other mash schedules, it's very important to have good insulation.

## PROCEDURE

**1. COLLECT THE STRIKE WATER** - you will need 1.75 qt. of water for every pound of grain to be mashed (more water will be needed if there is a large foundation space, empty space between the false bottom and the bottom of the mash vessel). In a kettle, heat the strike water to 134°F. Pour the heated water into the mash tun. Slowly add the grist to the water in the mash tun, stirring well to prevent clumping. The temperature should stabilize at 122°F. Proteolytic enzymes are active from 113° to 131°F. Do not exceed 150°F during this step, or you may destroy the enzymes needed for protein breakdown. **NOTE:** to add an optional acid rest, strike 1 qt. of water per pound of grist at 100°F and rest for 15 minutes; add hot water to raise the mash temperature to the protein rest and proceed as below.

### 2. PROTEIN REST FOR 20 TO 30 MINUTES.

**3. REMOVE 1st DECOCTION.** When the protein rest is complete, remove the first decoction. Using a measuring cup or strainer, collect in the decoction kettle 1 qt. of thick mash for every pound of grain used in the mash. Leave behind as much liquid as possible - there should be just enough liquid in the thick mash to fill up the spaces between the kernels. Gently heat the decoction, stirring to prevent sticking and scorching - use very low heat. If necessary, a small amount of water can be added to reduce the risk of scorching and make stirring easier. Boil the decoction for up to 30 minutes.

**TIP:** Scorching will occur early in the decoction if at all! Heat very slowly to start, and increase the rate of heating later as needed.

**4. RETURN 1ST DECOCTION.** When the first decoction has been boiled, return about 75% of the decoction to the mash to raise the temperature to the saccharification range. Stir and measure the temperature, and add more decoction to further raise the temperature as needed. Stir and measure the temperature after each addition - you may not need to add the entire decoction back to the mash. The temperature should stabilize between 149° and 158°F - refer to your recipe for the exact saccharification rest temperature to be used. Do not exceed 168°F during this step, or you may destroy the enzymes needed for starch conversion.

**NOTE:** if you reach the correct saccharification rest temperature before the entire decoction is returned to the main mash, add cold water to the remaining portion of the decoction to cool it to saccharification temperature, then add it back to the main mash.

### 5. SACCHARIFICATION REST FOR 60 MINUTES.

**6. REMOVE 2nd DECOCTION.** When the saccharification rest is complete, remove the second decoction. You will need to collect in the decoction kettle enough thin mash to equal about half of the volume of mash water that you started with - i.e., if you started with 12 qt. of strike water, collect about six qt. of thin mash. It will be easiest to remove this portion using a spigot on the mash vessel - don't worry if the thin mash is cloudy or contains particles of grain. Gently heat the decoction, stirring occasionally - scorching shouldn't be a problem with the thin mash. Boil the decoction for up to 30 minutes.

**7. COLLECT AND HEAT SPARGE WATER.** While the decoction is heating, collect and heat sparge water.

**8. RETURN 2ND DECOCTION.** When the second decoction has been boiled, return about 75% of the decoction to the mash; repeat the procedure for the first decoction to raise the temperature to mash-out. Proceed with sparging as with an infusion mash.

## PRINCIPLES AND ADVICE

A decoction mash uses the same rests as a multiple-step infusion mash; the difference with decoction mashing is that a portion of the mash - the decoction - is removed from the mash tun, slowly heated to boiling, and then added back to the main mash to raise the temperature to the next rest. In addition to the results achieved with multiple-step infusion mashes, decoction mashing also has these effects:

- Physically breaks down unconverted starches and proteins, making them more accessible to enzymes and increasing extraction
- Enhances malt aroma and flavor in the finished beer
- Boiling the decoction degrades the most complex starch and protein molecules, speeding up conversion and increasing the creation and extraction of sugars from the grain. Also, a boiled decoction is very dense and low in pH, so it does not extract astringent compounds from the grain.
- Triggers chemical reactions that form melanoidins. These same reactions occur when caramelizing onions or searing a steak. For brewing purposes, melanoidins deepen the color of the wort and provide a more intense malt aroma and flavor.
- Some decoction mash schedules include an acid rest of 15 - 20 minutes at 95°F, prior to the protein rest. An acid rest is used to lower the pH of very pale, low-modified malts and extremely soft, low-calcium water by creating phytate, a malt enzyme. This optional step helps thoroughly solubilize the grist, washing enzymes out of the malt and into solution and hydrating the proteins and starches in the kernels; a well-solubilized mash makes for fast conversion and easy mixing.
- Because the decoction is heated to boiling, any enzymes contained in it are destroyed before they can be added back to the main mash. To ensure complete breakdown of protein and conversion of starches, it's important that the thick mash is predominantly grain. The great majority of the enzymes will be contained in the liquid portion, the thin mash, once the grain is mixed with water. Most of the thin mash should remain in the mash vessel when the decoction is removed.
- The final decoction, for both double and triple decoctions, raises the mash temperature from saccharification to mash-out. Because conversion is complete and the enzymes will not be needed after this point, the final decoction consists of thin mash - it's easier to collect and boil.

## DOUBLE DECOCTION

Protein Rest --> Decoction 1 (Thick Mash) --> Saccharification Rest --> Decoction 2 (Thin Mash) --> Mashout

## ALTERNATE DOUBLE DECOCTION W/ ACID REST

Acid Rest --> Infusion --> Protein Rest --> Decoction 1 (Thick Mash) --> Saccharification Rest --> Decoction 2 (Thin Mash) --> Mashout

## TRIPLE DECOCTION

Acid Rest --> Decoction 1 (Thick Mash) --> Protein Rest --> Decoction 2 (Thick Mash) --> Saccharification Rest --> Decoction 3 (Thin Mash) --> Mashout

How long to boil a decoction depends on the beer being brewed. A decoction for a pilsner-style lager needs to be boiled only very briefly to preserve the pale color, while a doppelbock mash will become darker and richer by boiling the decoction for up to 30 minutes.

Is decoction mashing worth the trouble? Its detractors argue that there isn't enough difference between a decoction-mashed beer and an infusion-mashed beer to justify the extra time and labor. Its proponents argue that the rich maltiness of many German and Czech beers can't be reached without it, and that breweries like Erdinger, Ayinger, Bitburger, Plzensky Prazdroj (the brewers of Pilsner Urquell), Paulaner, et al., wouldn't decoction mash if it wasn't important to the character of their beers.

## FURTHER READING

**BREWING LAGER BEER (2ND EDITION)** Gregory Noonan

**HOW TO BREW** John Palmer

**THE BREWER'S COMPANION** Randy Masher