

SHIMANO FD-MOUNT

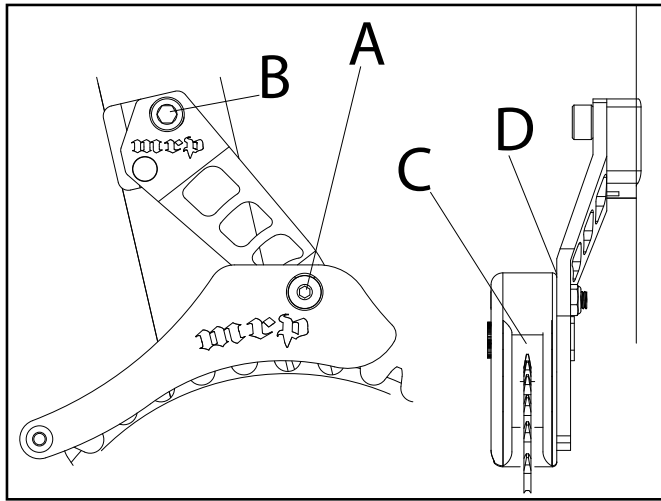

The Shimano FD-Mount 1X will accommodate chainrings from 32-40T. As with any MRP chainguide, the chainring should be mounted in the middle position on the crank spider (usually on the inside of the mounting tabs).

mrp

1X

This version of the 1X has two points of adjustment, the mounting bolt and upper guide bolt. Adjust the 1X vertically by moving the upper guide bolt (A) up and down on the guide track. Adjusting the mounting bolt (B) will affect the tilt of the guide. You will want to leave approximately 3-4mm of clearance between the chainring teeth and the ceiling of the 1X (C). The chainring should be aligned with the seam in the upper guide. There are two 1mm nylon spacers installed on the upper guide bolt between the guide and the bracket, you may remove one or both of the spacers as needed to achieve this alignment (D).

For optimal performance MRP recommends using single-ring specific chainrings - like our Podium rings - with the 1X guide.

FOR MORE INFORMATION PLEASE VISIT US ON THE
WEB AT **MRPBIKE.COM**
OR CALL US AT (970)241-3518 AND WE'LL BE GLAD TO
ASSIST YOU



580 NORTH WESTGATE DR.
GRAND JUNCTION, CO 81505

INSTRUCTIONS FOR
MTB SEAT TUBE &
SHIMANO FD-MOUNT
MODELS

IMPORTANT CONSUMER SAFETY INFORMATION

WARNING: RIDING A BIKE IS DANGEROUS. NOT PROPERLY MAINTAINING OR INSPECTING YOUR BIKE AND IT'S COMPONENTS IS EVEN MORE DANGEROUS. IT IS ALSO DANGEROUS TO NOT READ AND FOLLOW THESE INSTRUCTIONS.

1. Do not perform any modifications or adjustments that are not outlined in this manual.
2. Inspect your chain guide before every ride. Inspect areas for any signs of excessive rubbing, bending, cracking or other damage. If you notice anything abnormal, do not ride it. Return it to your dealer or contact MRP for a complete inspection and necessary repair.
3. MRP recommends that you wear proper safety equipment every time you ride, including approved bicycle helmet. Never ride at night without lights.
4. Always use genuine MRP parts. Use of aftermarket replacement parts and upgrades voids the warranty and could cause structural failure.

MRP highly recommends that you have your new guide installed by a professional mechanic at your favorite local bike shop. If you have ANY doubts about how to install your guide, take it to a bike shop. You'll be glad you did.

READ THE INSTRUCTIONS COMPLETELY BEFORE YOU BEGIN

PLEASE NOTE:

THE FOLLOWING DIRECTIONS ASSUME THAT THE FRONT DERAILLEUR, SHIFTER, AND ANY ADDITIONAL CHAINRINGS HAVE BEEN REMOVED FROM THE BIKE IF RETROFITTING THE 1X TO A BIKE PREVIOUSLY FITTED WITH MULTIPLE FRONT GEARS. ALL DRIVETRAIN COMPONENTS BUT THE CHAIN SHOULD BE INSTALLED BEFORE INSTALLING THE 1X GUIDE.

THE 1X GUIDE IS NOT COMPATIBLE WITH CRANK-MOUNTED BASH GUARDS.

MTB SEAT TUBE MOUNT

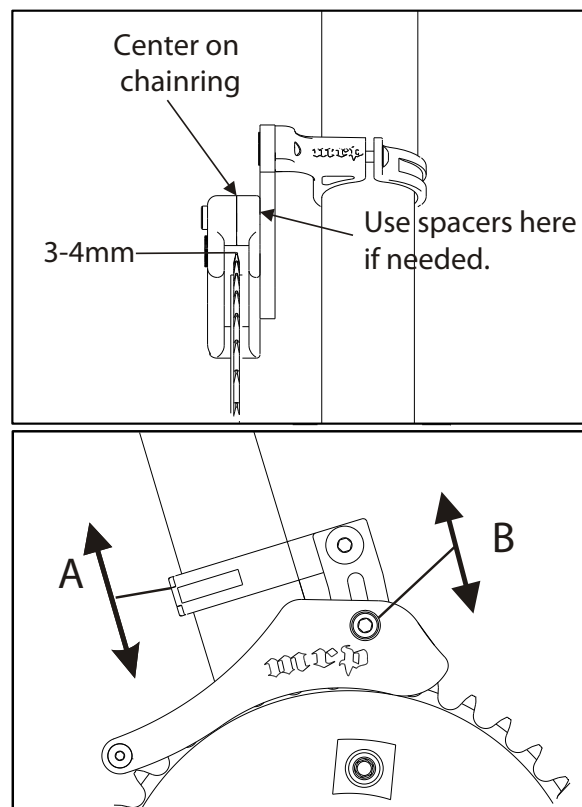

The MTB Seat Tube 1X is designed for 72-74 degree seat tube angles and will accommodate the following seat tube diameters:

**34.9MM
USE NO RUBBER SHIM**

**31.8MM
USE THIN RUBBER SHIM**

**28.6MM
USE THICK RUBBER SHIM**

The MTB Seat Tube Mount 1X will accommodate chainrings from 32-40T. As with any MRP chainguide, the chainring should be mounted in the middle position on the crank spider (usually on the inside of the mounting tabs). The chainring should be aligned with the seam in the upper guide. There are two 1mm nylon spacers installed on the upper guide bolt between the guide and the bracket, you may remove one or both of the spacers as needed to achieve this alignment.

Adjust the 1X vertically by moving the clamp (A) up and down the seat tube, or by moving the guide up and down on the guide track (B). You will want to leave approximately 3-4mm of clearance between the chainring teeth and the ceiling of the 1X. Install the chain and check for rubbing on the ceiling and tail of the guide, adjusting accordingly.

For optimal performance MRP recommends using single-ring specific chainrings - like our Podium rings - with the 1X guide.