

HARKEN[®]

Battcar Installation Manual
System B CB and Slider Cars
6mm Clevis Pin

CB/Slider Systems

Parts List

Thank you for purchasing Harken's B Battcar system. Please read manual before assembling system.

Headboard Cars (Assembly)

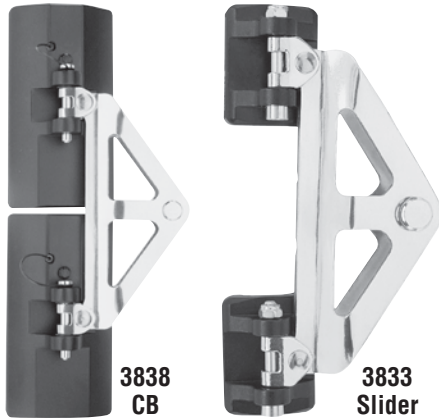

Intermediate Cars



Universal Battcar



Reef Car



Batten Cars without Receptacle

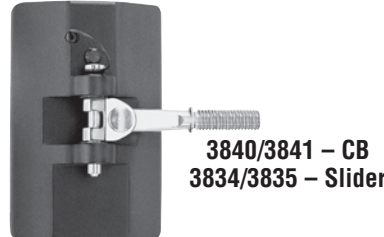

You will need these tools:

- Tape Measure
- Phillips Screwdriver
- Power screwdriver
- Drill / Drill Bit: 17/64" (6.5 mm)
- Hex wrench: 5 mm
- Nut Driver: 10 mm or Open/Box Wrench
- Centerpunch / Hammer
- Putty knife / Hacksaw / File / Tape

Mast-Up Installation: Stepladder secured to the boat.
Work Height: 7' (2.13 m) above boom.

Track Mounting Kit 3845, 3846

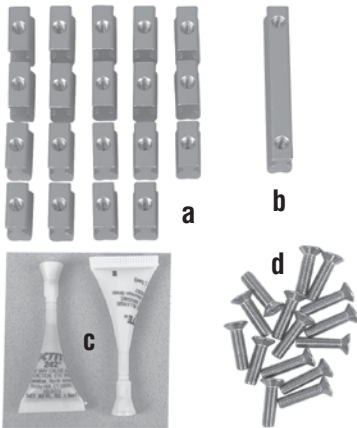

Spare Car Screws



Screwpin Endstop Kits 3847, 3848



Endstop Kits 3850, 3851

Track (Mounting Slug Type)

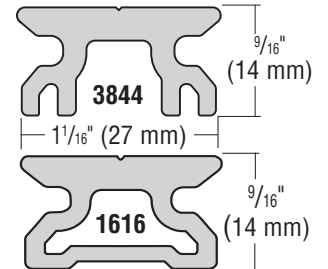

Track (Drill and Tap Type)

CB/Slider System Parts

CB System Part No.	Slider System Part No.	Description	Comments
3838	3833	Headboard cars	
3839	3836	Intermediate cars	If battens are close enough intermediate cars are not needed.
3840	3834	Batten car	10 mm Threaded stud. Purchase batten receptacle separately.
3841	3835	Batten car	12 mm Threaded stud. Purchase batten receptacle separately.
3842	—	Universal Battcar	Purchase batten receptacle and threaded stud separately.
3843	—	Reef Tack car	Requires special track with closer hole spacing

Track and Accessories

Part No.	Description	Includes
3845, 3846	Track Mounting Kit	(a) 19 mounting slugs 7/8" (22 mm); (b) 1 connector slug 3" (76 mm); (c) 2 Tubes Blue Loctite®; (d) 21 HFS321 Flathead screws 6 x 20 mm.
3847 3848	Screwpin Endstop Kit	(e) 1 end track with screwpin stop; (f) 1 top stop slug 1 1/16" (36 mm); (g) 1 top endstop 1522A; (h) 1 mounting slug 7/8" (22 mm); (i) 2 HFS321 flathead screws 6 x 20 mm; (j) 2 HFS1037 flathead screws 6 x 30 mm; (k) 1 tube blue Loctite®.
3850, 3851	Endstop Kit	(g) 2 endstops 1522A; (i) 4 HFS1037 flathead screws 6 x 30 mm; (f) 2 stop slugs 1 1/16" (36 mm)
3844	Track (slug type)	Section length: 6'9 1/8" (2.06 m). Number of track sections depends on luff length of your mainsail.
1616	Track (drill and tap type)	Use for masts without grooves or when slugs will not fit. Purchase stainless steel 1/4" (6 mm) screws separately. Do not use 3844 track. It requires mounting slugs. See page 8 for drill/tap sizes and mounting instructions.

Sizing

Make sure that you have the correct size battcar system for your boat.

Maximum Sail Area Monohull	Maximum Sail Area Multihull	Part No. Headboard	Part No. Battcars	Part No. Intermediate Cars
CB System				
900 ft ² 83 m ²	700 ft ² 65 m ²	3811	3840, 3841	3839
Slider System				
900 ft ² 83 m ²	700 ft ² 65 m ²	3833	3834, 3835	3836

Sail Modifications

See page 12.

- Mainsail Headboard
 - Drill new halyard location
 - Drill Attachment to accept clevis pin for #3833 or 3838 headboard car coupler.
- Batten receptacle on sail to accept 10 mm threaded stud. **Note:** Harken does not supply receptacle.
- Becket spacer on sail for 3839 (CB) or 3836 (slider) intermediate cars.

CB/Slider Systems

Track Length

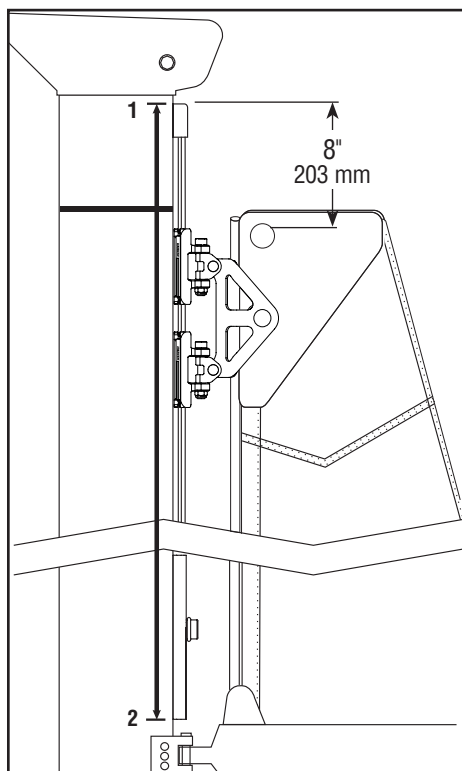

Number of Track Sections

Bottom endstop track and variable length top track included.

Track Length	Number of 6'9 1/8" (2.06m) Track Sections
41'6" to 48'2" 12.649 m to 14.681 m	7
48'3" to 54'11" 14.707 m to 16.739 m	8
55'0" to 61'8" 16.764 m to 18.796 m	9
61'9" to 68'5" 18.821 m to 20.853 m	10
68'6" to 75'2" 20.879 m to 22.911 m	11

Determine Track Length

Measure track length from point 1 to point 2. See diagram at left. Use this measurement in two charts to follow.

1. Upper End—8" (203 mm) above black band. Track is longer than sail luff length to allow for stretch as sail ages. Track *must not* block halyard exit.

2. Lower End, Using 3847, 3848—Bottom of track will be approximately 3/8" (10 mm) above gooseneck fitting. When installed, track should be as low as possible yet you should still be able to install long headboard cars. Test measurement by using long headboard car. See photo above.

3850, 3851 Endstop Kit—Cut a 9 3/8" (238 mm) piece from finished end of one of the 6'9 1/8" (2.06 m) 3844 tracks. You will remove this track when loading cars so it can be lower on mast. See page 7, step 11. Drill lower hole for stop. See page 5, step 3.

Round track length to nearest 1" (25 mm).

NOTE: Chart is based on using a 9³/₈" (238 mm) or 9¹/₂" (241 mm) lower end track.

Total Track Length (as defined on page 3)									Top Track Length	
41' 6"	12.649 m	48' 3"	14.707 m	55' 0"	16.764 m	61' 9"	18.821 m	68' 6"	20.879 m	1 ¹ / ₂ " 38 mm
41' 7"	12.675 m	48' 4"	14.732 m	55' 1"	16.789 m	61' 10"	18.847 m	68' 7"	20.904 m	2 ³ / ₈ " 60 mm
41' 8"	12.700 m	48' 5"	14.757 m	55' 2"	16.815 m	61' 11"	18.872 m	68' 8"	20.930 m	3" 76 mm
41' 10"	12.751 m	48' 7"	14.808 m	55' 4"	16.866 m	62' 1"	18.923 m	68' 10"	20.980 m	5" 127 mm
42' 0"	12.802 m	48' 9"	14.859 m	55' 6"	16.916 m	62' 3"	18.974 m	69' 0"	21.031 m	7" 178 mm
42' 2"	12.852 m	48' 11"	14.910 m	55' 8"	16.967 m	62' 5"	19.025 m	69' 2"	21.082 m	9" 229 mm
42' 4"	12.903 m	49' 1"	14.961 m	55' 10"	17.018 m	62' 7"	19.075 m	69' 4"	21.133 m	11" 279 mm
42' 6"	12.954 m	49' 3"	15.011 m	56' 0"	17.069 m	62' 9"	19.126 m	69' 6"	21.184 m	1' 1" 330 mm
42' 8"	13.005 m	49' 5"	15.062 m	56' 2"	17.120 m	62' 11"	19.177 m	69' 8"	21.234 m	1' 3" 381 mm
42' 10"	13.056 m	49' 7"	15.113 m	56' 4"	17.170 m	63' 1"	19.228 m	69' 10"	21.285 m	1' 5" 432 mm
43' 0"	13.106 m	49' 9"	15.164 m	56' 6"	17.221 m	63' 3"	19.279 m	70' 0"	21.336 m	1' 7" 483 mm
43' 2"	13.157 m	49' 11"	15.215 m	56' 8"	17.272 m	63' 5"	19.329 m	70' 2"	21.387 m	1' 9" 533 mm
43' 4"	13.208 m	50' 1"	15.265 m	56' 10"	17.323 m	63' 7"	19.380 m	70' 4"	21.438 m	1' 11" 584 mm
43' 6"	13.259 m	50' 3"	15.316 m	57' 0"	17.374 m	63' 9"	19.431 m	70' 6"	21.488 m	2' 1" 635 mm
43' 8"	13.310 m	50' 5"	15.367 m	57' 2"	17.424 m	63' 11"	19.482 m	70' 8"	21.539 m	2' 3" 686 mm
43' 10"	13.360 m	50' 7"	15.418 m	57' 4"	17.475 m	64' 1"	19.533 m	70' 10"	21.590 m	2' 5" 737 mm
44' 0"	13.411 m	50' 9"	15.469 m	57' 6"	17.526 m	64' 3"	19.583 m	71' 0"	21.641 m	2' 7" 787 mm
44' 2"	13.462 m	50' 11"	15.519 m	57' 8"	17.577 m	64' 5"	19.634 m	71' 2"	21.692 m	2' 9" 838 mm
44' 4"	13.513 m	51' 1"	15.570 m	57' 10"	17.628 m	64' 7"	19.685 m	71' 4"	21.742 m	2' 11" 889 mm
44' 6"	13.564 m	51' 3"	15.621 m	58' 0"	17.678 m	64' 9"	19.736 m	71' 6"	21.793 m	3' 1" 940 mm
44' 8"	13.614 m	51' 5"	15.672 m	58' 2"	17.729 m	64' 11"	19.787 m	71' 8"	21.844 m	3' 3" 991 mm
44' 10"	13.665 m	51' 7"	15.723 m	58' 4"	17.780 m	65' 1"	19.837 m	71' 10"	21.895 m	3' 5" 1.041 m
45' 0"	13.716 m	51' 9"	15.773 m	58' 6"	17.831 m	65' 3"	19.888 m	72' 0"	21.946 m	3' 7" 1.092 m
45' 2"	13.767 m	51' 11"	15.824 m	58' 8"	17.882 m	65' 5"	19.939 m	72' 2"	21.996 m	3' 9" 1.143 m
45' 4"	13.818 m	52' 1"	15.875 m	58' 10"	17.932 m	65' 7"	19.990 m	72' 4"	22.047 m	3' 11" 1.194 m
45' 6"	13.868 m	52' 3"	15.926 m	59' 0"	17.983 m	65' 9"	20.041 m	72' 6"	22.098 m	4' 1" 1.245 m
45' 8"	13.919 m	52' 5"	15.977 m	59' 2"	18.034 m	65' 11"	20.091 m	72' 8"	22.149 m	4' 3" 1.295 m
45' 10"	13.970 m	52' 7"	16.027 m	59' 4"	18.085 m	66' 1"	20.142 m	72' 10"	22.200 m	4' 5" 1.346 m
46' 0"	14.021 m	52' 9"	16.078 m	59' 6"	18.136 m	66' 3"	20.193 m	73' 0"	22.250 m	4' 7" 1.397 m
46' 2"	14.072 m	52' 11"	16.129 m	59' 8"	18.186 m	66' 5"	20.244 m	73' 2"	22.301 m	4' 9" 1.448 m
46' 4"	14.122 m	53' 1"	16.180 m	59' 10"	18.237 m	66' 7"	20.295 m	73' 4"	22.352 m	4' 11" 1.499 m
46' 6"	14.173 m	53' 3"	16.231 m	60' 0"	18.288 m	66' 9"	20.345 m	73' 6"	22.403 m	5' 1" 1.549 m
46' 8"	14.224 m	53' 5"	16.281 m	60' 2"	18.339 m	66' 11"	20.396 m	73' 8"	22.454 m	5' 3" 1.600 m
46' 10"	14.275 m	53' 7"	16.332 m	60' 4"	18.390 m	67' 1"	20.447 m	73' 10"	22.504 m	5' 5" 1.651 m
47' 0"	14.326 m	53' 9"	16.383 m	60' 6"	18.440 m	67' 3"	20.498 m	74' 0"	22.555 m	5' 7" 1.702 m
47' 2"	14.376 m	53' 11"	16.434 m	60' 8"	18.491 m	67' 5"	20.549 m	74' 2"	22.606 m	5' 9" 1.753 m
47' 4"	14.427 m	54' 1"	16.485 m	60' 10"	18.542 m	67' 7"	20.599 m	74' 4"	22.657 m	5' 11" 1.803 m
47' 6"	14.478 m	54' 3"	16.535 m	61' 0"	18.593 m	67' 9"	20.650 m	74' 6"	22.708 m	6' 1" 1.854 m
47' 8"	14.529 m	54' 5"	16.586 m	61' 2"	18.644 m	67' 11"	20.701 m	74' 8"	22.758 m	6' 3" 1.905 m
47' 10"	14.580 m	54' 7"	16.637 m	61' 4"	18.694 m	68' 1"	20.752 m	74' 10"	22.809 m	6' 5" 1.956 m
48' 0"	14.630 m	54' 9"	16.688 m	61' 6"	18.745 m	68' 3"	20.803 m	75' 0"	22.860 m	6' 7" 2.007 m
48' 2"	14.681 m	54' 11"	16.739 m	61' 8"	18.796 m	68' 5"	20.853 m	75' 2"	22.911 m	6' 9 ¹ / ₈ " 2.060 m

CB/Slider Systems

Cut Top Track to Length

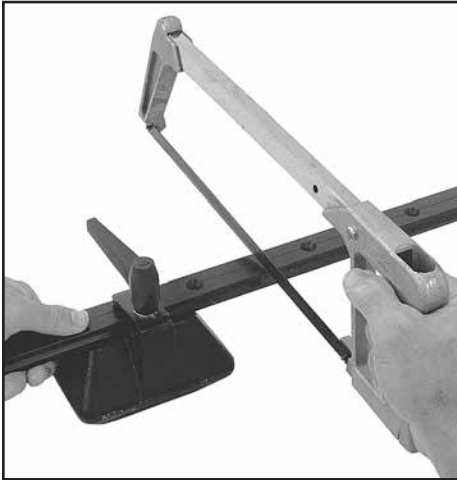

1. Cut special length top track from 6'9 1/8" (2.06 m) track.



2. Deburr cut.

Slightly round track corners that will slide against mast.

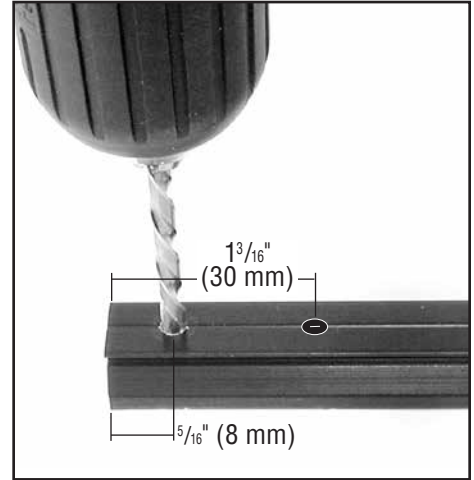

3. Drill two 17/64" (6.5 mm) holes in cut end of track. Center at 5/16" (8 mm) and 1 3/16" (30 mm)

Short top track lengths

1 1/2" (38 mm)	Use existing hole. Do not drill second hole.
2 3/8" (60 mm)	Use existing hole, drill hole 5/16" (8 mm) from cut end.

CB/Slider Systems

Check Fit of Mounting Slugs & Car

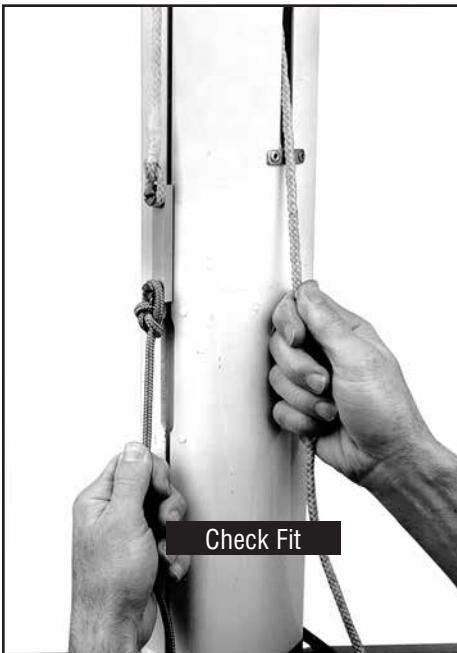

3" (76 mm) connector slug must fit feeder opening. File opening to make longer.

Use halyard with retrieval line to run 3" (76 mm) connector slug up mast to check for burrs in groove.

Mast prebend: May require straightening before installation.

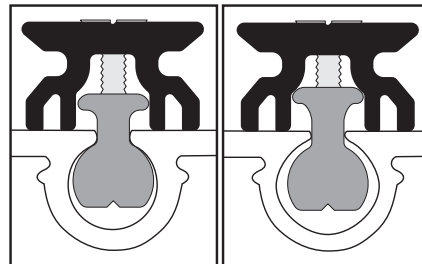

Test track: Put mounting slug in groove, track section on mast. Tighten with screw.

Mounting screw must be long enough for mast groove. If necessary, purchase longer screws.

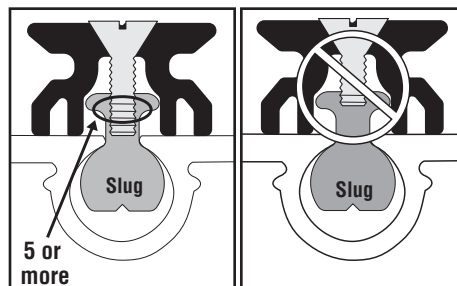

Warning! Screws need minimum 5 threads (turns) engaged to hold track to mast.

Turn screw 360° five times after threads engage slug.

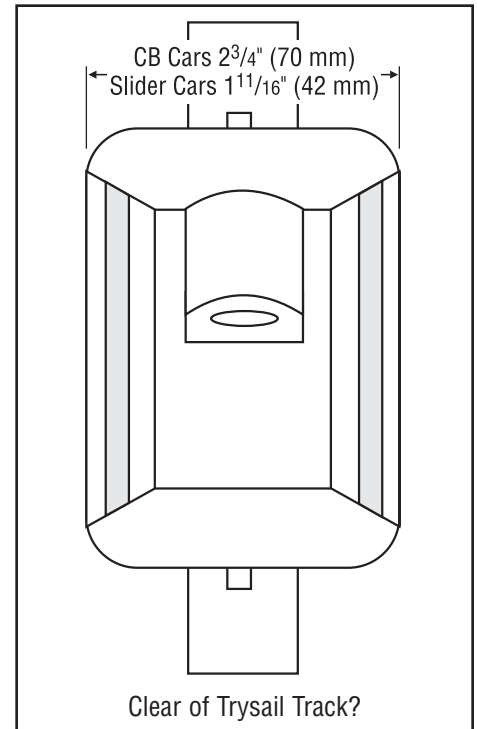

Cars must clear storm trysail track. Tracks often converge above spreaders.

Aft face of mast must be flat or convex.



1. Slip top track slugs into mast groove. Use 1 7/16" (36 mm) mounting slug for top stop.

Short top track lengths	Top slug
1 1/2" (38 mm)	3" (76 mm)
2 3/8" (60 mm)	7/8" (22 mm)

Install 3" (76 mm) connector slug at bottom.

Mast up: Tape 1 7/16" (36 mm) slug even with top of upper track. Tape other slugs in place.

2. One drop blue Loctite® into each connector slug hole.

3. Thread a 6 x 20 mm screw through endstop, track, and into endstop slug.

Short top track lengths

1 1/2" (38 mm)	Use one screw in stop
2 3/8" (60 mm)	Use both screws

Mast up: Remove tape. Tighten screw to hold track.

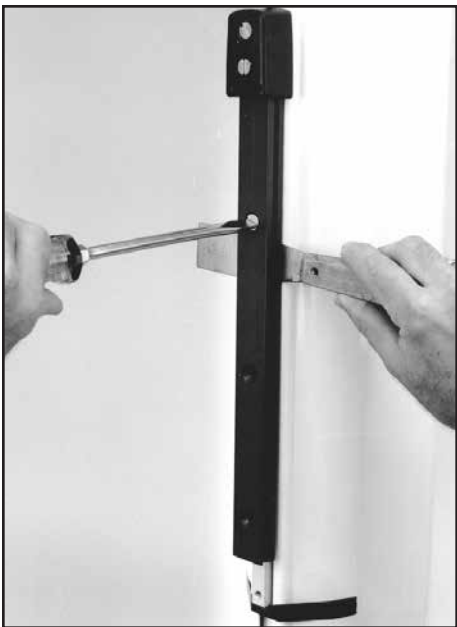

4. Slide slugs into place with putty knife. Loosely install 6 x 20 mm screws.

5. Loosen top screw. Slide top track up and position next 6'9 1/8" (2.06 m) track.

Mast up: Tighten bottom screw to hold track.

6. Slide 19 mounting slugs and connector slug into mast groove.

Mast up: Tape in place.

Put one drop blue Loctite® into each hole.

TIP: Use putty knife to see if screws are loose enough to slide in groove.

REMEMBER: Tracks may stick when reaching a spliced area on mast.



7. Hold full-length track piece up to mast. Loosely install top screw.

Use putty knife to slide additional slugs and connector slug into place. Loosely install all nineteen 6 x 20 mm screws.



8. Slide tracks up enough to fit next track.

Mast up: Hold upper tracks. Loosen screw that holds tracks. Slide track up. If screws bind in mast groove opening, loosen them until track slides. Tighten new bottom screw securely.

WARNING! Do not let tracks drop. Severe injury can result.

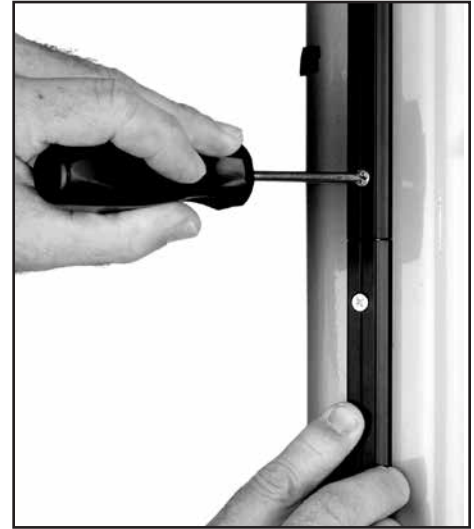

9. Repeat until full-length tracks installed.

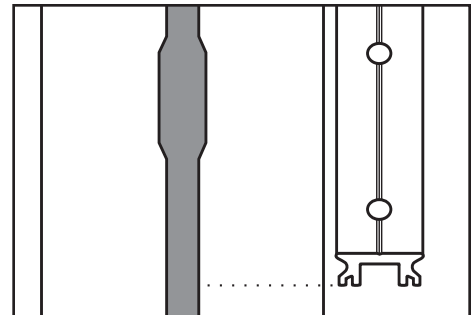

NOTE: If bottom full-length track blocks feeder gap, load bottom track slugs before installing track.

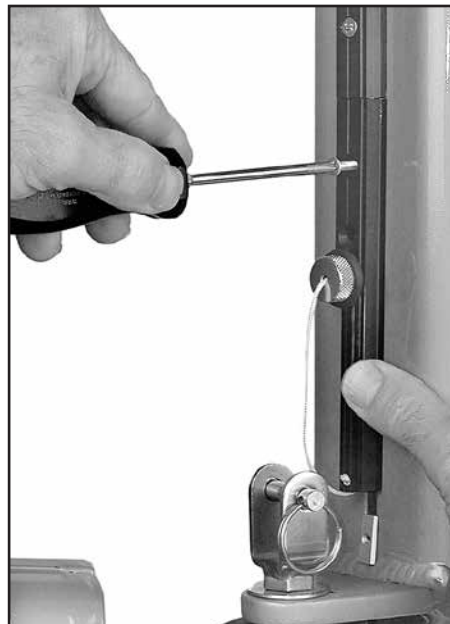

10. Raise tracks so 9 1/2" (241 mm) bottom feeder track fits.

11. Install bottom feeder track with stop.



3850, 3851 Endstop Kit—leave bottom 9 3/8" (238 mm) track off until cars are installed.

Required Parts

1616 Track

Determine Track Length.

Bottom track must be short enough to remove easily. Use 18" to 24" (457 mm to 609 mm) length. Do not use 3844 track for drilling and tapping.

1/4" (6 mm) Flathead Screws (not included) 10 fasteners/meter of track

1619 Splices

3850/3851 Endstop Set

Drill and Tap sizes		
	U.S. Imperial	Metric
Drill	13/64"	5 mm
Tap	1/4-20	m6 x 1

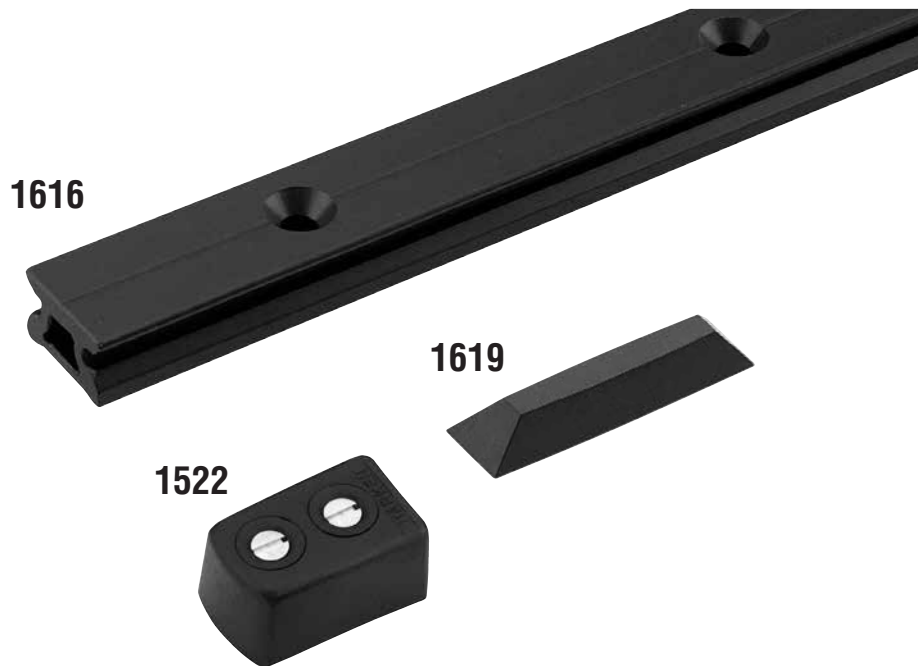

Removing Old Track

Track on mast: Before removing, scribe pencil line down either side of track.

Track off mast: Attach string to mast to line up track during installation.

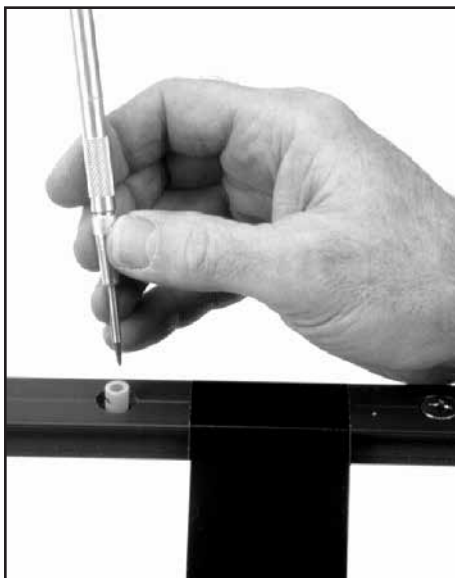

1. Drilling, tapping, screwing: Start at one end of track and work down: Do not drill and tap from both track ends

Clamp or duct tape track on mast. Center punch hole in center of track hole.

TIP: Use narrow shaft spring-loaded machinist's center punch with plastic centering tube or transfer punch.



2. Drill track hole, holding drill perpendicular to mast face. Tap threads and install screws using blue Loctite®.

TIP: Use low speed drill with tap for cutting threads.

IMPORTANT: Use blue Loctite® instead of oil for tapping lubricant.

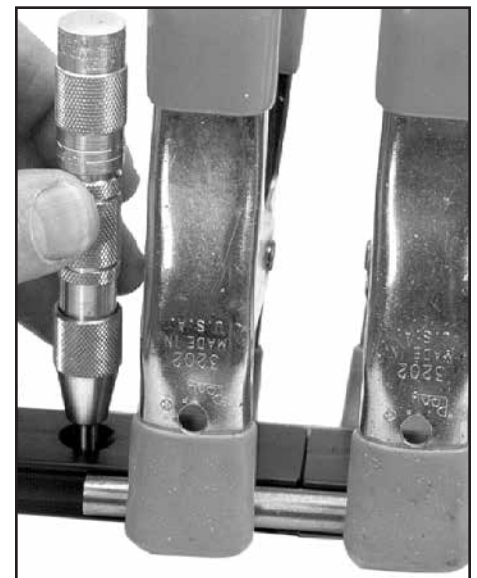

3. Align track at joints: Use 1619 splice pieces and round rods or dowels to align track during installation. Hold in place with spring or "C" clamps until track is secured.

Load all cars before installing bottom track and endstop.

IMPORTANT: To keep balls captive we recommend loading cars onto track without sail installed. Chart below shows correct number of balls for each car.



1. Headboard car: Hold car so cap screw head faces up. Align car on guide section of loader track and gently roll onto upper tracks. If cars stick, realign and roll onto track.



2. Load intermediate car (if used). Alternate with batten cars until all cars are loaded.

Mast up: Use halyard to hold cars.



3. Install screw stop.

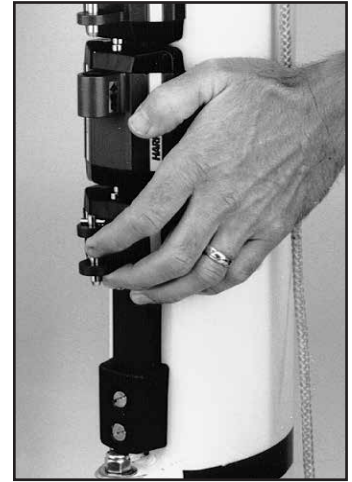

3850, 3851 Endstop Kit— Remove bottom 9½" (241 mm) track and install cars.

TIP: Use halyard to hold tracks up

TIP: To load headboard car assembly, angle headboard coupler. Roll car onto tracks. If necessary, remove headboard assembly.

CB System

Lost Balls

Consult ball chart below to find number of balls for each car. To load balls, place car on edge with retaining clip in place. Insert balls one-by-one from center of clip and roll into return race. **Do not overfill car.**

Part Number	Car Type	Length		Color	Bearing Material	Quantity per Car	Part No.	Balls/Set	Ball ø	
		in	mm						in	mm
3838	Headboard Cars (2)	5 ⁵ / ₁₆	132	Brown	Torlon®	60	1526	25	⁵ / ₁₆	8
3839	Intermediate Car	2 ⁹ / ₁₆	68	Brown	Torlon®	28	1526	25	⁵ / ₁₆	8
3840	Battcar w/10 mm Threaded Stud	4 ¹ / ₄	108	Brown	Torlon®	40	1526	25	⁵ / ₁₆	8
3840	Battcar w/12 mm Threaded Stud	4 ¹ / ₄	108	Brown	Torlon®	40	1526	25	⁵ / ₁₆	8
3842	Universal Car	4 ¹ / ₄	108	Brown	Torlon®	40	1526	25	⁵ / ₁₆	8
3843	Reef Car	5 ⁵ / ₁₆	132	Brown	Torlon®	60	1526	25	⁵ / ₁₆	8



Slider System

Load Cars on Track

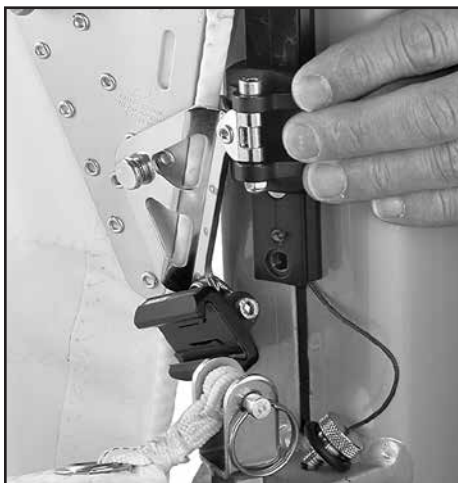

Slider cars can be loaded onto tracks with or without sail attached.

Line up car on guide portion of loader. Press car towards mast and slide car onto track. Begin with upper cars and work down.

TIP: To load headboard car assembly, angle headboard. Roll car onto tracks. If necessary, remove headboard assembly.



Slider System

Load Sail on Cars



1. Beginning with lower cars, use 5 mm hex wrench and 10 mm wrench or nut driver to attach sail to cars. Tighten locknut until bottom tip of fastener is flush with nut.

Do not over tighten. Make sure toggle can pivot.



2. Screw threaded stud to terminal.

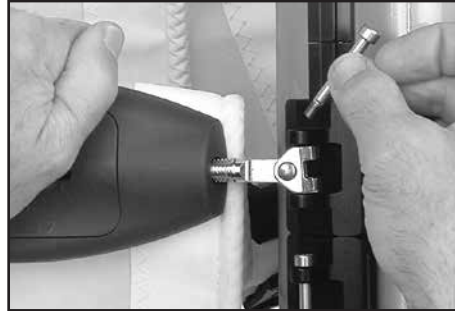

3. Load toggle using 5 mm hex wrench and 10 mm wrench or nut driver. Tighten locknut. **Do not over tighten.**



4. Attach head of sail to headboard car with clevis pin and cotter pin.

CB System

Load Sail on Cars

Attach sail to system beginning with lowest car. Line up toggle and insert clevis pin.

If it is a “no wind” day, hoist mainsail as you attach sail to cars.



CB System

Removing Sail

Press quick release button and push up on bottom of pin. Remove clevis pin.



Slider System

Removing Sail

If your system has slider battcars without ball bearings, leave slides attached and slide cars off, beginning at the bottom.



CB System

Battcar Operating Precautions

When lowering sail, do not let halyard go. Ease cars down by keeping a wrap on winch.

On boats with unstayed masts, vang must be used to prevent over rotation of upper part of sail. Over rotation can damage batten receptacles.

CB System

Car Maintenance

Clean beginning of season, or if cars bind. Squirt detergent and water into ball bearings. Circulate by moving cars up and down. Let stand. To remove detergent, spray water into ball bearings and circulate. Clean tracks with detergent and water.

Inspect Battcar fittings for loose locknuts. Replace. Inspect batten receptacles for loose screws.



CB/Slider Systems

Lazy Jacks

Lazy Jacks

Use shock cord to hold lazy jacks open so battcars and battens will not catch on them. This will also help stop slapping of lazy jacks on sail.

Attach one end to lower spreader tips and the other to lazy jacks.

Make sure shock cord is long enough so boom can swing out all the way without damaging spreaders.

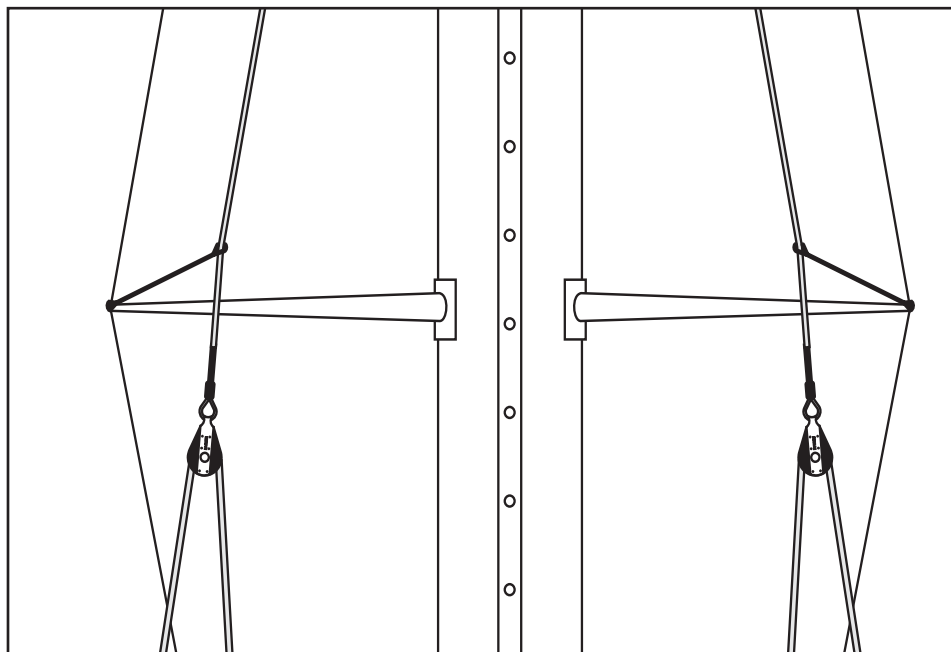

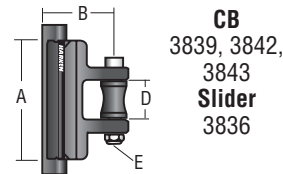
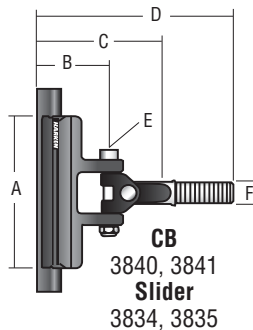
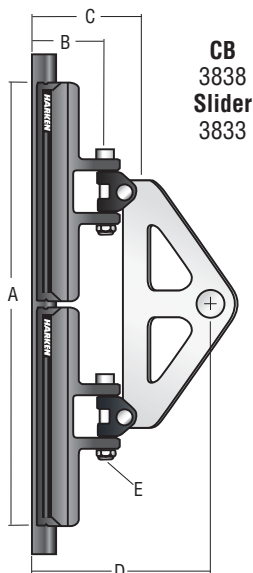

Dimensions (measured from aft face of mast)

Part No.	Description	A		B		C		D		E	F	
		in	mm	in	mm	in	mm	in	mm	Pin Ø	Stud Ø	
System B CB												
3838	Headboard car assembly	10 1/2	267	1 7/16	36	2 13/16	71	4 7/16	110	1/4	6	—
3839	Intermediate car	2 9/16	68	1 7/16	36	—	—	3/4	19	1/4	6	—
3840	Battcar/10 mm stud	4 5/16	109	1 7/16	36	2 13/16	71	5 1/16	129	1/4	6	10
3841	Battcar/12 mm stud	4 1/2	114	1 7/16	36	2 13/16	71	5 1/16	129	1/4	6	12
3842	Universal Battcar	4 1/4	108	1 7/16	36	—	—	3/4	19	1/4	6	—
3843	Reef car	5 3/16	132	1 7/16	36	—	—	3/4	19	1/4	6	—
System B Slider												
3833	Headboard car assembly	7 1/2	190	1 1/4	32	2 1/4	57	4 5/8	119	1/4	6	—
3834	Battcar/10 mm stud	2 9/16	56	1 1/4	32	2 1/4	57	3 9/16	91	1/4	6	10
3835	Battcar/12 mm stud	2 3/16	56	1 1/4	32	2 1/4	57	3 3/4	96	1/4	6	12
3836	Intermediate car	2 3/16	56	1 1/4	32	—	—	—	—	1/4	6	—

CB/Slider Systems

Headboard coupler attaches to standard headboards —some headboard modification required.

Maximum thickness of headboard plates and sail: 3/16" (14 mm)

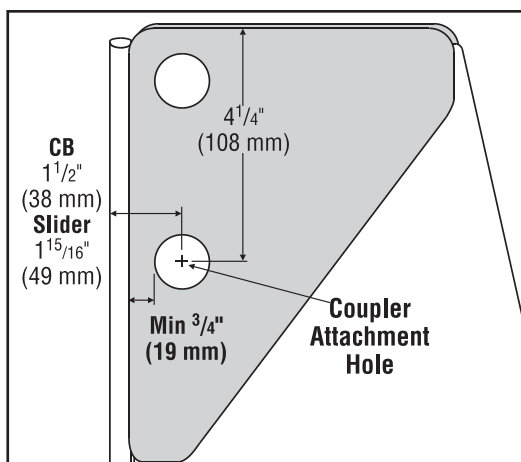

Coupler Attachment Hole

Drill 5/8" (16 mm) coupler attachment hole so center is 4 1/4" (108 mm) from top of headboard and centered from front edge of boltrope:

- CB** 1 3/8" (35 mm)
- Slider** 1 7/8" (22 mm)

Leave at least 3/8" (9 mm) between front of headboard plate and front edge of coupler attachment hole.

Installing Headboard Car Assembly

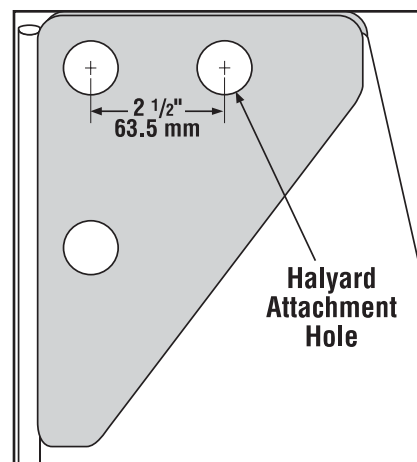

Halyard Attachment Hole

Use aft hole if headboard has two.

If not, drill second hole to accept halyard shackle pin. Locate hole approximately 2 1/2" (63.5 mm) aft of existing hole.

Distance Between Attachment Points

Battens and intermediate cars placed at sailmaker's discretion. Maximum distance between attachment points is 4' to 4'6" (1.2 m to 1.35 m).

Distance may be slightly greater. Contact Harken to discuss sail reshaping to eliminate luff flutter.

NOTE: Adding battens may reduce stack height by eliminating intermediate cars.

Setting Reef Points

Space reef points halfway between sail attachment points. Battens or reef points may need to be moved. Diagram A

NOTE: Batten fittings and cars cannot handle reefing outhaul or downhaul loads. Transfer loads to a tack fitting. Diagram B

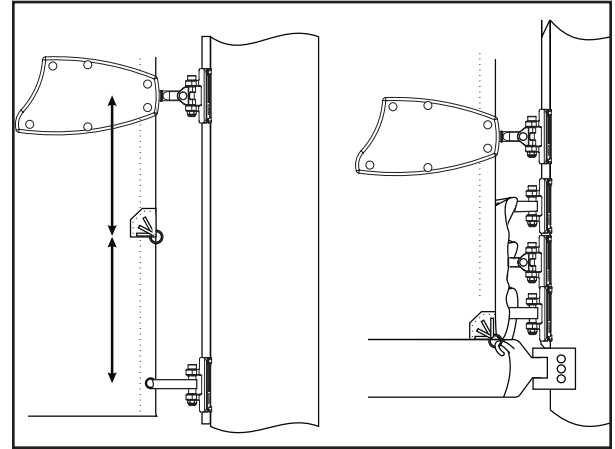

DIAGRAM A

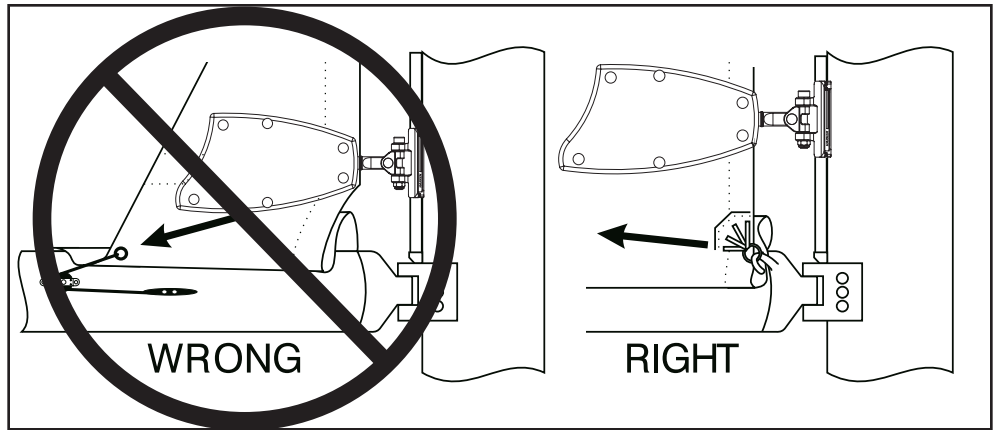

DIAGRAM B

CB/Slider Systems

Sail setback from luff tape to intermediate car clevis pin:

CB	3839	– 1¼" (32 mm)
Slider	3836	– 1" (25 mm)

Plastic spacers come with 3839 and 3836 intermediate cars. Seize spacer to webbing by stitching just behind plastic spacer. Seize webbing to sail by stitching up against sail.

Combining Intermediate Slider Cars with CB Cars

If you combine 3836 Slider Intermediate cars with CB cars use the 1⅜" (35 mm) CB setback shown above.

Attaching Sail to Intermediate Cars

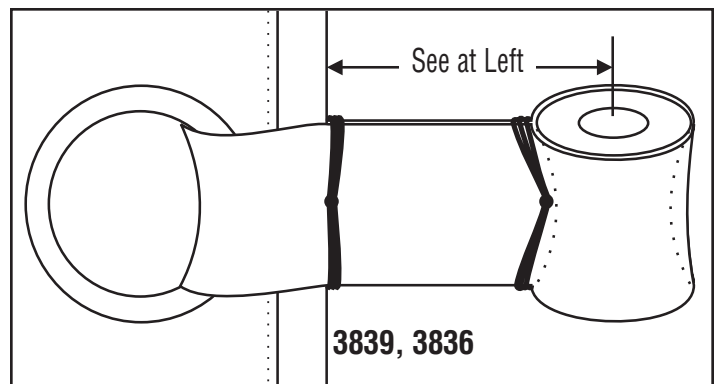

Problem	Probable Cause	Solution
Tracks do not butt up against each other	Cut end of top or bottom track is at joint. Track weight pulling tracks apart.	Make sure the anodized end is towards the full length track. Tracks will come together when you loosen the bottom screw and push the tracks up the mast.
Mounting slugs do not fit	Slugs wrong size.	Different size slug required. Contact your dealer.
Mounting screws will not tighten.	Incorrect mounting slug used.	Different size slug required. Contact your dealer.
Track will not slide up mast.	Slugs catching on mast splice.	Loosen screws slightly. If necessary have someone at splice area to wiggle the slug past the splice.
	Corners of cut track catching.	Use file to round off corners of track.
	Mast has too much prebend.	Ease backstay and/or straighten mast.
	Paint or other material clogging mast groove.	Clean out groove.
CB/Slider cars do not fit on track.	Track and cars are not the same size.	Contact your dealer or Harken.
CB cars do not fit on track	Balls are missing.	Remove cars, load balls and slide cars back on track.
Sail headboard does not fit inside coupler.	Ring was not pressed far enough.	Take sail to sailmaker.

Problem	Probable Cause	Solution
CB cars bind.	Balls missing from car.	Remove cars, load balls and slide cars back on track.
	Dirt in cars.	Use detergent and fresh water to flush dirt out of cars; move cars up/down do circulate; follow with high pressure water; clean track grooves.
Nut on Battcar is not holding.	Locknut has been used too many times.	Get new 6 mm locknut.
Batten receptacle does not rotate.	Nuts are too tight.	Loosen nuts slightly.
Cars jam when raising sail.	Headboard or cars are catching on lazy jacks.	Use topping lift or rod vang and shock cord to pull lazy jacks out to shrouds.
Sail will not go all the way up.	Sail is too tall or sheave is too far forward.	Have sail shortened or move sheave aft.
Vertical post or pin on batten receptacle bending.	Reef loads are being transferred to batten receptacle.	Transfer reef downhaul and outhaul loads to mast or boom gooseneck.
Reef tack fitting will not reach reef hook.	Reef point too close to sail attachment.	Move intermediate car sail attachment.

HARKEN[®]

N15W24983 Bluemound Rd.
Pewaukee, Wisconsin 53072 USA
Telephone: (262) 691-3320 • Fax: (262) 701-5780
Web: www.harken.com • Email: harken@harken.com