

HARKEN®

CUSTOM PRODUCTS

General installation guide and maintenance manual – Intended for specialized personnel or expert users

M1026 07-19

Table of contents

Introduction

General safety warnings	2
Training and expertise	2
Applications and limitations of products	2
Anodizing shade variations	2

Installation and system design

Important loading considerations	3 - 4
Important mounting and corrosion considerations	5

General inspection and maintenance

Intervals defined	6
Short-term basic procedures	6-7

Long-term inspection and maintenance

General comments	8
Megayacht blocks	9 - 10
V blocks	11 - 12
TTR2 blocks	13 - 14
Wood blocks	15
Fixed padeyes	16 - 18
Removable padeyes	19 - 26
CRX traveler systems	27
Sample maintenance schedule	27
Notes	28 - 31

Warranty and contact information	32
---	-----------



Please read these instructions carefully before installing, servicing, or operating the equipment.
This manual may be modified without notice. See: www.harken.com/manuals for updated versions.

PLEASE SAVE THESE INSTRUCTIONS



WARNING! Strictly follow all instructions to avoid potential hazards that may kill or hurt you and others. See www.harken.com/manuals for General Warnings and Instructions.



WARNING! Before using make sure that all people and objects are clear of the moving components of the system.

See General Warning and Instructions in the beginning of the Harken catalog or linked at the bottom of the opening page of the website www.harken.com.

Training and expertise

This manual provides technical information on inspection and service. The user must have appropriate training in order to specify, design mounting, use, and maintain this product. Installation, disassembling and reassembling by personnel who are not experts can cause serious damage to property or injury to users and those in the vicinity of the product. If you do not understand an instruction, contact Harken.

Harken accepts no responsibility for damage or harm caused by not following the safety requirements and instructions in this manual.

Applications and limitations of products

Harken custom hardware is designed for specific sailboat applications and includes modified or specially designed components. Conditions for using Harken products have limitations. Contact Harken custom engineering if there are any questions about the application.

Harken custom products have been designed for use in a marine saltwater environment provided regular maintenance is followed.

Anodizing shade variations: Titanium color or other non-black colors

Although every effort is made, Harken cannot guarantee that all aluminum parts in a system will have the same shade of grey. The process of anodizing converts aluminum to aluminum oxide, providing parts with a protective finish. Slight variations in the alloy's chemical makeup and the process used to produce raw material can change the shade of the anodizing. This is purely cosmetic. The functional characteristics of the anodizing remain the same and have been validated.

This manual provides basic information on inspection and maintenance of custom products. Following are limited general considerations and installation warnings. This information is not intended to give specific installation instructions or design line-handling systems. Customer assumes responsibility for correctly specifying, mounting and aligning the product in order to achieve the product's rated load capacity by:

- **Mounting in applications** where load does not exceed product's Maximum Working Load
- **Mounting to structures** that are equal or greater than product's Maximum Working Load
- **Mounting to anchors** such as padeyes or bails that are equal or greater than product's Maximum Working Load

- Fastening **soft-attach lashings** or loops to the correct opening in block

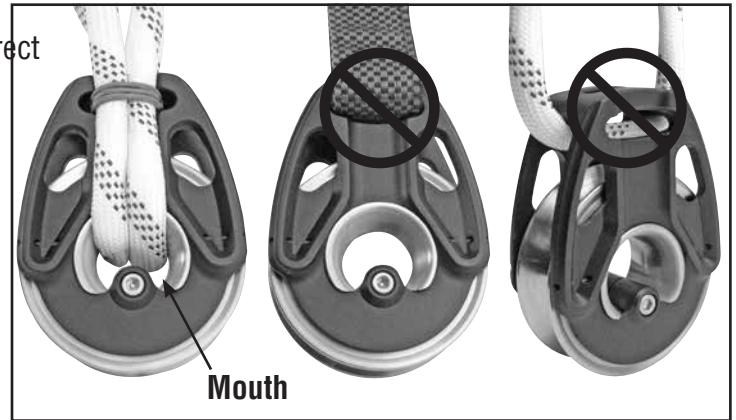

- Using **fastener size, type, and quantity** as dictated by product design and meeting or exceeding Maximum Working Load
- Using **fastener material** meeting or exceeding Maximum Working Load

- Factoring **line turning angle** and effect on loading

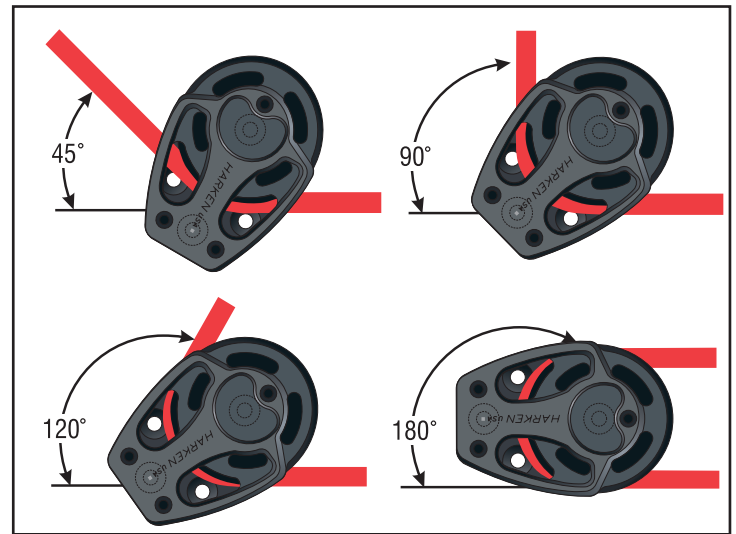

Angle of deflection	Load factor	Angle of deflection	Load factor	Angle of deflection	Load factor
30°	52%	90°	141%	150°	193%
45°	76%	105°	159%	160°	197%
60°	100%	120°	173%	180°	200%
75°	122%	135°	185%		

- **Aligning fasteners correctly to load** when using fixed products such as footblocks



Correct



Incorrect



Correct

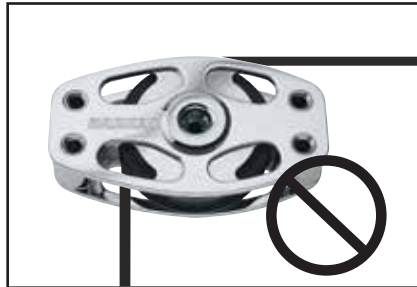

Incorrect

- **Aligning padeyes** so bail is correctly aligned with load

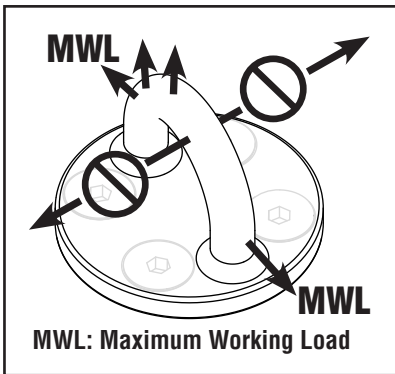

- Following other specific **industry-wide best practices** for standing and running rigging factoring line turning angle and effect on loading

- **When mounting traveler tracks and other deck hardware:** Install traveler track on a flat area of the deck that is capable of bearing a load equal at least twice the maximum working load of the traveler car to be used. Reinforce deck if necessary. It is installer's responsibility to carry out all structural tests needed to ensure that the deck can bear the load. If in doubt about the correct track position and deck strength, consult the yard that built the boat.
- **Choosing fasteners** - Carefully choose fasteners made from A4 (316) stainless steel. Make sure to use large washers or backing plates and lock washers or locknuts. It is installer's responsibility to choose correct screws, nuts, washers, and threaded plates, taking account materials and loads they will have to bear. Harken assumes no responsibility for incorrect installation of track or for an incorrect choice of mounting fasteners.
- **Material isolation** - When mounting aluminum track or other hardware, use Tef-Gel[®] between track and fastener to prevent corrosion. If mounting track to dissimilar metal or carbon mounting surface, track must be isolated to prevent galvanic corrosion. When planning track installation, carefully consider materials used in mounting structures to avoid corrosion damage to track. Do a material analysis between stainless steel fasteners and the mounting structure materials to determine the risk of track corrosion where fasteners contact track. Consult with a materials expert if necessary. Use Duralac[®] compound or similar in track fastener holes and counter-sink areas to isolate fasteners from track. **IMPORTANT!** Pay careful attention to isolate fasteners when mounting to carbon fiber or aluminum decks including teak decks atop aluminum.
- **Sealant** - Choose a sealant in the fastener holes what will effectively prevent water ingress.
- **Electrical discharge** - Take measures to control stray voltage aboard yacht. Consult with a marine metallurgical electronic corrosion expert to determine the source of electrical discharge to reduce corrosion inducements.
- **Inspection** - Frequently inspect tracks and other hardware near fasteners to determine if there is corrosion developing. If necessary remove fasteners and inspect. It may be necessary to remount track, carefully isolating fasteners and track using Duralac compound or similar. Replace tracks immediately if there are signs of corrosion.

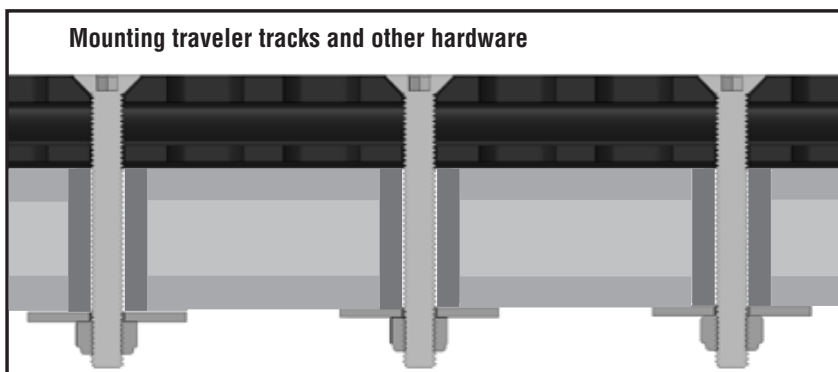

Contact Harken custom department - If there are any questions on new or existing equipment regarding mounting applications, specific maximum working load, or availability of replacement parts, contact Harken custom. Please include dimensions, photos of product, and installation to help identify the product and application.

Basic cleaning procedure

Frequently flush with fresh water; periodically clean with mild detergent and water solution. Spin sheaves, rotate cams, and roll cars back-and-forth to distribute soap solution evenly.

Clean bearings by flushing areas shown, while rotating sheave or moving traveler car.

After cleaning, make sure parts move freely as designed. If there is too much friction or there is a scraping sound, do not use the part until cause is determined. Replace parts as necessary.

Short-term basic inspection and cleaning:

Block – Inspect all fasteners and parts. Tighten, replace and use thread-locking solution as directed. Spray soapy water into space between cheek and sheave as shown. Spin sheave to distribute. Flush with fresh water.

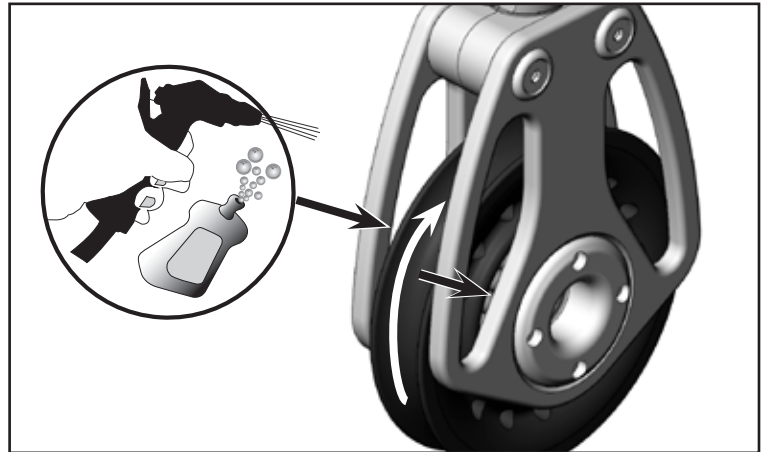

Padeyes - Inspect all fasteners and fastening components. Clean and inspect load-bearing components of padeye, lashings, and loops.



Travelers - Inspect all fasteners and parts. Move car assembly back-and-forth while flushing. Clean track. Do not use spray lubricants; ball bearings will skid, not roll. Once car and track are dry, apply one (1) to two (2) drops of McLube® OneDrop™ ball bearing conditioner to ball contact surfaces of track. Roll car back-and-forth to distribute OneDrop to rollers. Clean remaining OneDrop off track.

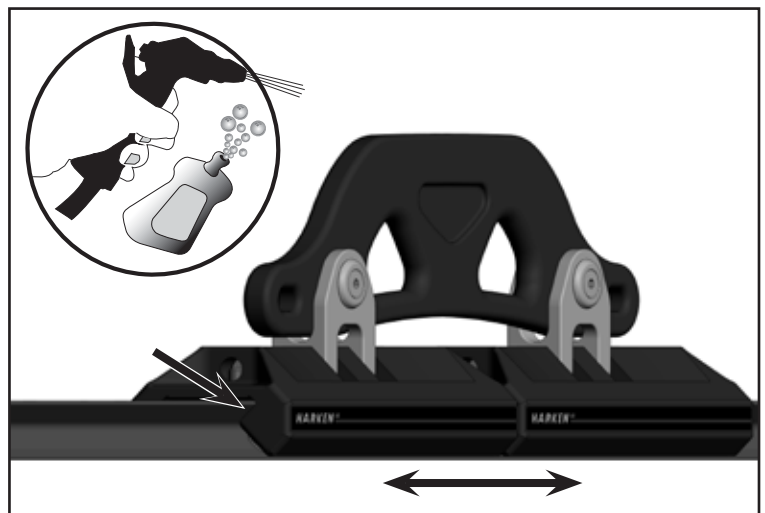

McLube is a registered trademark of McGee® Industries, Inc.
OneDrop is a trademark of McLube®, a Division of McGee Industries.

Long-term - general comments

This section has important introductory general statements.

Disassembly: Refer to basic images below. Drawings are available on the Harken website. Search using the product number or navigate via product category in the hardware tab. Alternatively, consult Harken custom engineering to understand how to disassemble, inspect, and clean all components. After inspection, replace worn or damaged components. Replace components with original Harken equipment.

Assembly, lubricants: In many cases, products do not use lubricants and must be just cleaned to remain free running. In other cases, ball conditioner or grease is used. Lubricated areas have specific locations and lubricants often must be kept away from other areas. Be sure to carefully note specific instructions below.

Assembly, fastener torque specifications: Torque settings for most custom products are not available. Some fastener suppliers give torque recommendations on their websites based upon fastener diameter and whether fasteners are lubricated or dry. As they point out, no two bolts respond the same to a given torque and are influenced by dirt in the threads or accuracy of the torque measuring device.

Storage: Storing products with saltwater on the interior can shorten the life of the product. Follow long-term maintenance procedures before long-term storage. Store in dry location.

IMPORTANT! Lack of adequate maintenance shortens the life of the product. Follow procedures and schedules below.

IMPORTANT! Do not grease product unless specified. Using grease can cause bearings to skid instead of roll. This causes wear. Follow maintenance instructions below.

IMPORTANT! Exposure to some teak cleaners and other caustic solutions can result in discoloration of part and is not covered under the Harken warranty.

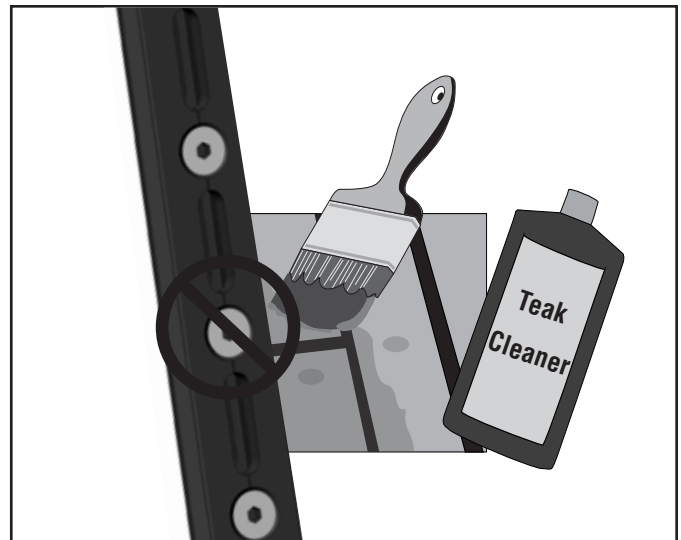

Intervals defined

The following basic and specific product sections divide maintenance and inspection into short and long term:

- 1. Short-term** – The frequency of short-term maintenance depends on several factors including sailing hours, conditions, and exposure to salt water spray. Follow short term maintenance whenever the decks are washed.
- 2. Long-term** – Keep equipment operating smoothly by overhauling and cleaning at least twice a year. Keep a log of sailing hours and conditions and develop specific regular overhaul type maintenance and inspection. Overhaul after prolonged use and before long-term storage. The frequency may be after a heavy air regatta or passage.
- 3. Immediate** – Overhaul immediately if parts are turning or traveling roughly, or if there are grinding sounds, especially metal-on-metal.

Short-term inspection and maintenance

This section covers basic inspection and maintenance performed on a regular basis as part of regular shore side cleaning assuring equipment is functionally ready at all times.

Short-term inspection guidelines

Inspect all components. Frequently look for weakness in these and other areas. Replace product or component immediately.

Product	Inspect and look for weakness in these areas
Padeye bails, shackles, and shackle posts	Signs of wear, corrosion, cracks, or elongation
Lashings and loops	UV damage, wear, or chafe. Replace if there is any question of strength. Note: When replacing shackles and loops, use Harken supplied or specified parts to maintain the proper strength.
Fasteners	Looseness or signs of wear, corrosion, cracks, or elongation. Stainless steel fasteners where they make contact with aluminum for signs of insufficient anti-corrosion compounds or electrical discharge problems aboard yacht. Use blue Loctite® adhesive to secure fasteners. Make sure threaded fastener and threaded holes are free of residue before installing. Carefully inspect for any signs of grease or lubricated anti-corrosion compounds and use solvent and small brush to remove before using blue Loctite. Note exceptions in this manual and others to using blue Loctite. In some cases Tef-Gel® lubricant is specified
Mounting plates	Damaged backing or anchor hardware for signs of weakness - Replace or repair
Mounting surface	Deterioration, cracking or crushing of substrate - Reinforce and repair
Operation	Make sure assembly moves freely. If there is increased friction, scraping or metal-on-metal sound, do not use the assembly until the cause is determined.
Drainage	Make sure that the holes and drainage channels are not obstructed so that water does not collect.

Short-term maintenance guidelines

To avoid expensive parts replacement, perform short-term maintenance regularly, especially if the boat will not be used for a while.

Tools and supplies

Soapy water solution

Freshwater hose

Traveler cars – use McLube® OneDrop™ conditioner

Loctite is a registered trademark of Henkel AG & Company KGaA.

Tef-Gel is a registered trademark of Ultra Safety Systems.

McLube is a registered trademark of McGee® Industries, Inc.

OneDrop is a trademark of McLube®, a Division of McGee Industries.

This section provides specific information on inspection and maintenance.

Perform long-term maintenance after prolonged use, before long term storage, if sheave is turning roughly, or if there is a grinding sound, especially metal on metal.

Tools and supplies

- Pin spanner wrench
- Soapy water solution
- Tef-Gel® lubricant
- Blue Loctite® adhesive

Note: Ball bearings are snap fit in grooves on sides of sheave. There is no need to catch balls

Sheave service

1. Refer to sample exploded views on next page for disassembly and assembly sequence.
2. Use soap and water to clean all parts. Rinse with fresh water.
3. Inspect balls. Replace if bearing surfaces are rough, scored, or have flat spots. Replace balls that fall out of sheave ball groove. If changing balls, note quantity of balls on drawing. Important! Do not overload balls or sheave will not function properly and can cause damage to parts.
4. If composite sleeve bearing in sheave is worn, return sheave to Harken to press new bearing into sheave.
5. Inspect all aluminum parts for signs of wear or corrosion. Replace as necessary.
6. When reassembling use Tef-Gel on areas where stainless steel and aluminum make contact. **IMPORTANT! Make sure Tef-Gel does not get near the ULC bearing or the ball bearings. Avoid areas indicated by arrows.**

7. Use blue Loctite to secure fasteners.

(See exploded views next page)

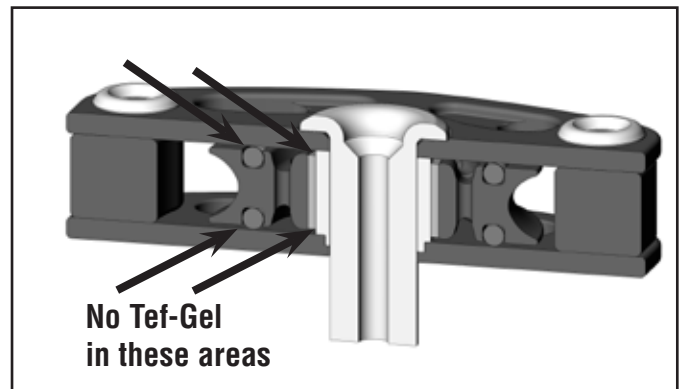

Loctite is a registered trademark of Henkel AG & Company KGaA.
Tef-Gel is a registered trademark of Ultra Safety Systems.

Exploded views

Use for disassembly and assembly sequence.

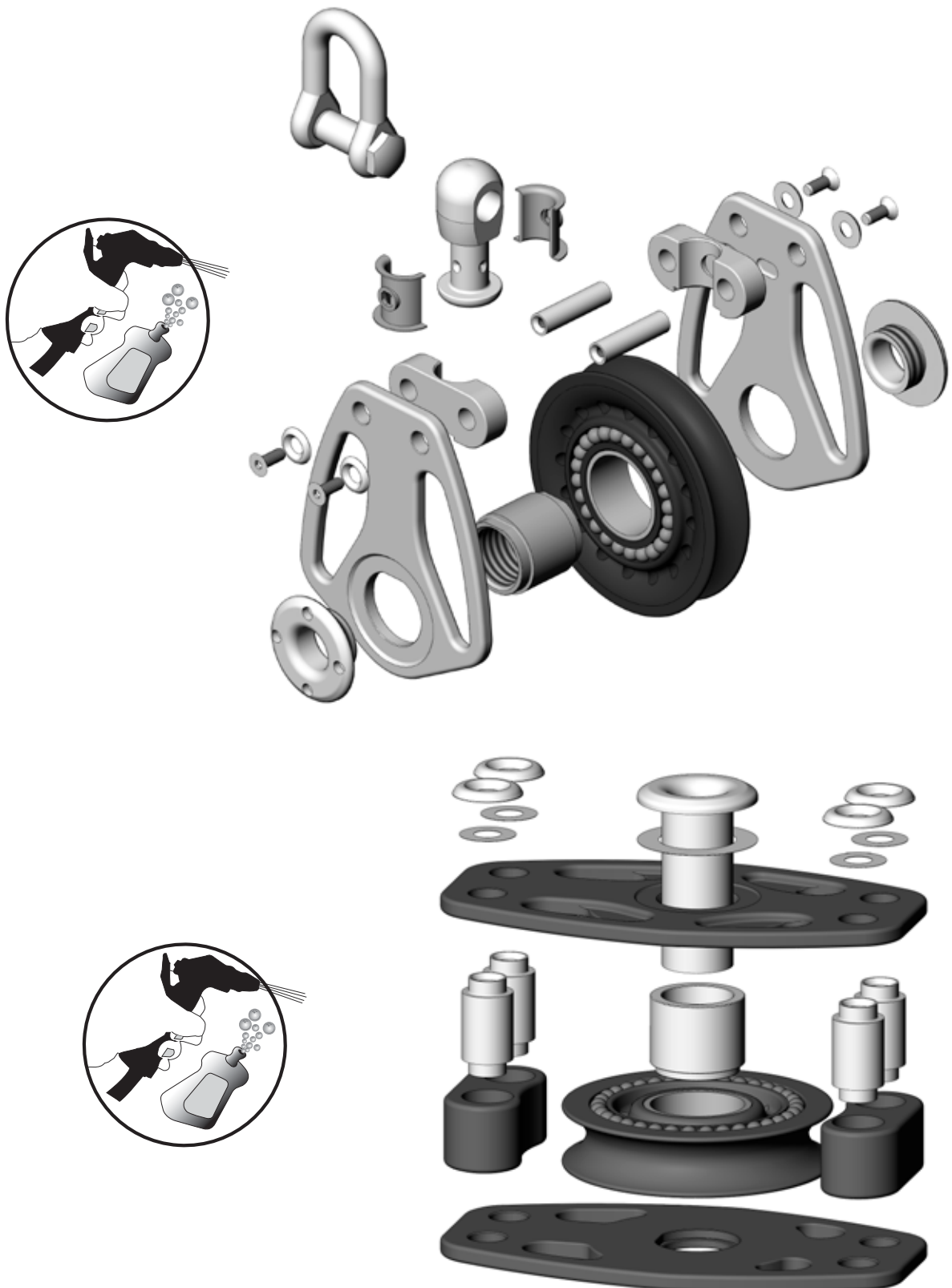

This section provides specific information on inspection and maintenance. See specific V Block instructions at www.harken.com/manuals. Look for manual 5097.

Perform long-term maintenance after prolonged use, before long-term storage, if sheave is turning roughly, or if there is a grinding sound, especially metal on metal.

Tools and supplies

- Metric hex key
- Soapy water solution
- Solvent to clean grease.
- Harken winch grease
- 222 Purple Loctite® adhesive

Note: V-Blocks do not use sload balls. There is no need to catch balls

Sheave service

1. Refer for sample exploded views below for disassembly and assembly sequence.
2. Use soap and water to clean all parts. Rinse with fresh water.
3. Inspect roller bearings. Replace if bearing surfaces are rough, scored, or have flat spots.
4. Inspect all aluminum parts for signs of wear or corrosion. Replace as necessary.
6. See next page for instructions regarding greasing bearings and races.

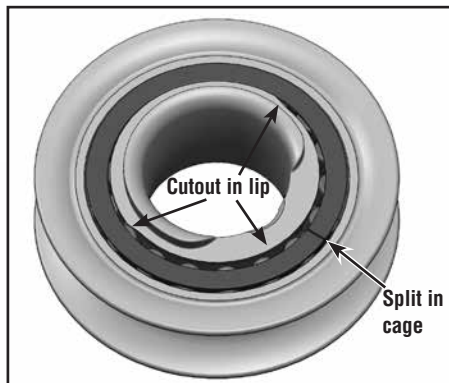

Sheave and bearing assembly: One side of inner race has a cutout in lip. Bearing cage is split. Use cutout and split cage to disassemble and reassemble. **IMPORTANT! Do not force cage or it can break.**

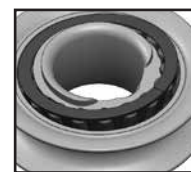

Split bearing cage and cutout in inner race lip

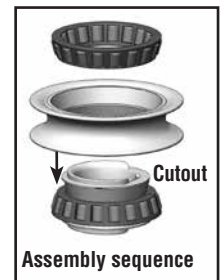

Assembly sequence

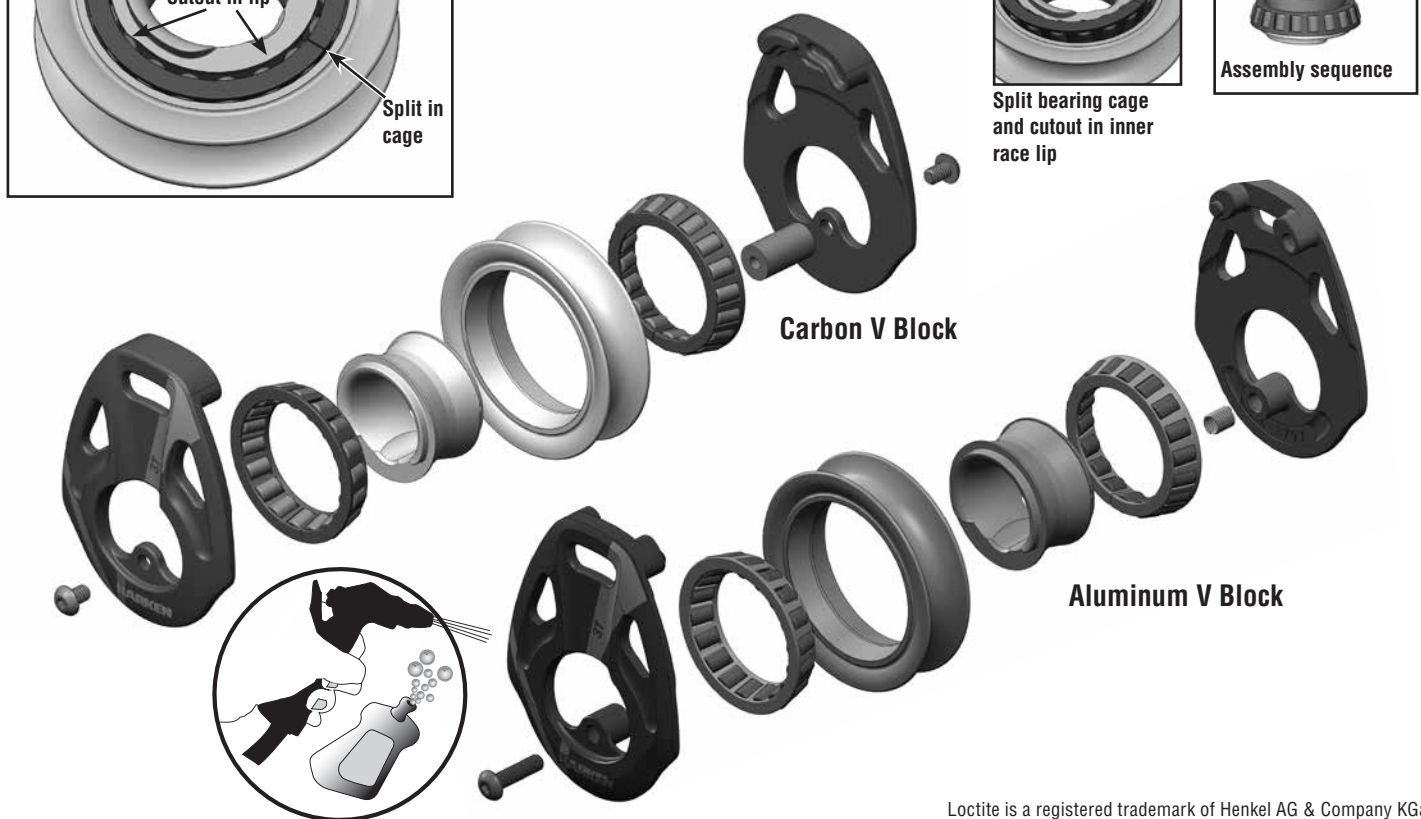

Sheave service (continued)

Disassemble using inner race cutouts and split in cage. **IMPORTANT!** Do not force bearing cage. See previous page for details.

Remove rollers for cleaning or replacement by pushing outward. Install from outside pushing in.



Inner race has a cutout on one side to allow removal of bearing assemblies. See previous page for details. When assembling block, there is no need to match lip cutout side to Alpha or Beta cheeks.

Lightly grease inner ring of sheave as shown at right.

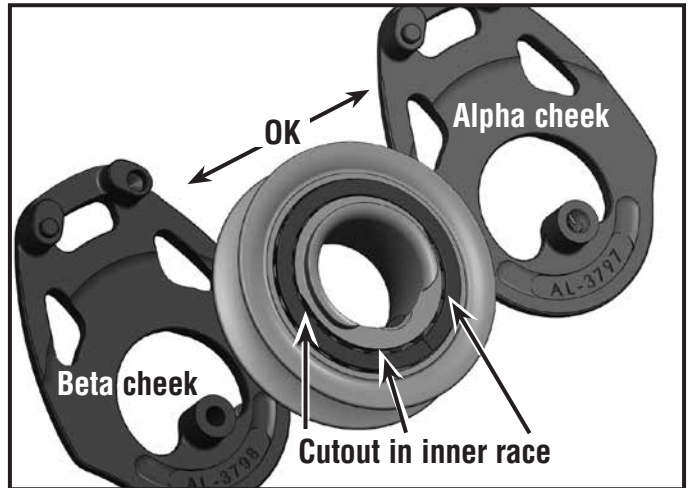

IMPORTANT! When assembling:
 3294AL - 1.5T block
 3295AL - 3.0T block
Start fastener from Beta cheek.
DO NOT insert from outside of Alpha cheek.

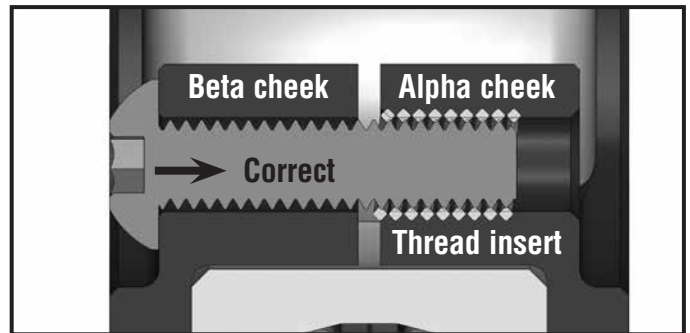

All blocks: Secure screw using Loctite® 222 purple thread locking solution. Use Mylar washer. See torque specifications on last page.



This section provides specific information on inspection and maintenance.
See specific TTR2 instructions at www.harken.com/manuals. Look for manual 4381.

Perform long-term maintenance after prolonged use, before long-term storage, if sheave is turning roughly, or if there is a grinding sound, especially metal on metal.

Tools and supplies

- Metric hex key
- Soapy water solution
- Solvent to clean grease.
- Harken winch grease
- Blue Loctite® adhesive

Note: Ball bearings are snap fit in grooves on sides of sheave. There is no need to catch balls

Sheave service

1. Refer for sample exploded views below for disassembly and assembly sequence.
2. Use soap and water to clean all parts. Rinse with fresh water.
3. Inspect roller bearings. Replace if bearing surfaces are rough, scored, or have flat spots.
4. Inspect all aluminum parts for signs of wear or corrosion. Replace as necessary.
6. See next page for instructions regarding greasing bearings and races.

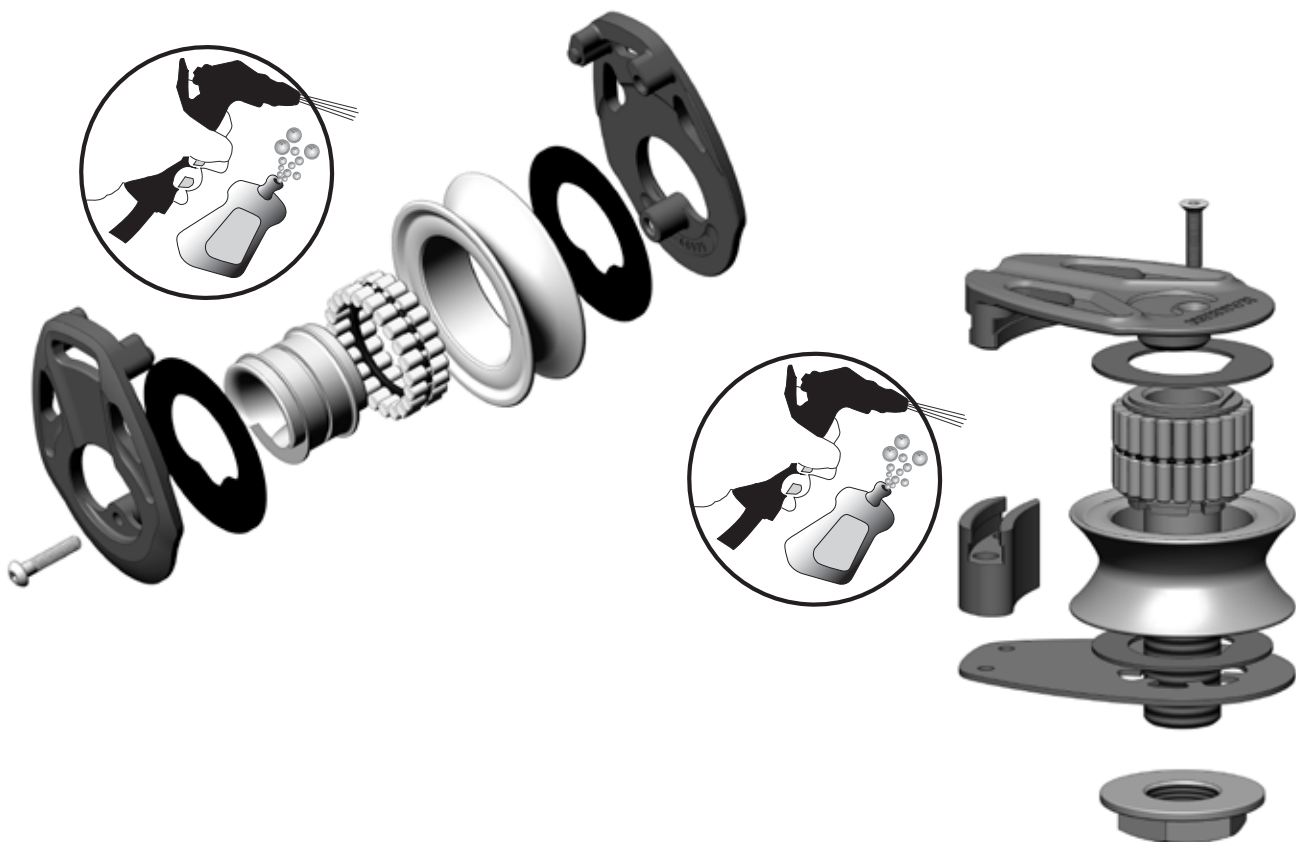

Loctite is a registered trademark of Henkel AG & Company KGaA.

Sheave service (continued)

Remove roller/cage assembly. Clean using solvent



Lightly grease inner ring of sheave as shown at right



Assemble block using blue Loctite® adhesive on screw



Loctite is a registered trademark of Henkel AG & Company KGaA.

This section provides specific information on inspection and maintenance.

Perform long term maintenance after prolonged use, before long term storage, if sheave is turning roughly, or if there is a grinding sound, especially metal on metal.

Tools and supplies

- Soapy water solution
- Screwdriver
- 1-part varnish
- Blue Loctite® adhesive

Sheave service

1. Refer to sample exploded view below for disassembly and assembly sequence.
2. Use soap and water to clean all parts. Rinse with fresh water. Thoroughly flush sheave and inner race.
3. If composite sleeve bearing in sheave is worn or makes grinding sound, return sheave to Harken.
4. Inspect all metal parts for signs of wear or corrosion. Replace as necessary.
5. Clean wood shell and dip in a 1-part varnish. **IMPORTANT!** Using a 2-part epoxy finish will damage the varnish and epoxy will not adhere correctly
6. Use blue Loctite to secure fastener.

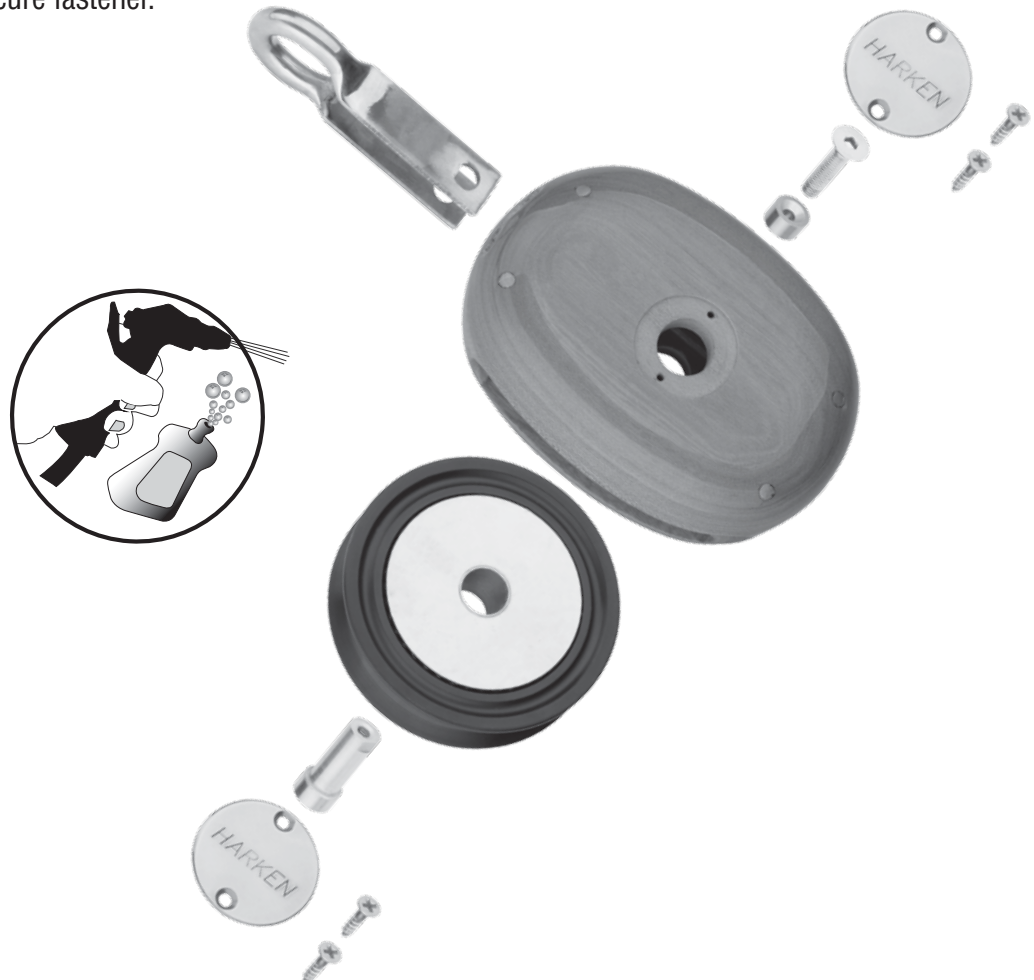

Perform long-term maintenance and inspection after prolonged use, before long-term storage, or if part has loosened.

Tools and supplies

- Hex key
- Soapy water solution
- Tef-Gel® lubricant
- Blue Loctite® adhesive

Padeye service

1. Refer to exploded view for sample disassembly.
2. Use soap and water to clean all parts. Rinse with fresh water. Thoroughly flush center cavity.
3. Remove and inspect loop or lashing especially at chafe points of loop against bail. Replace loop or lashing on a regular basis and immediately if there are signs of chafe or deterioration.
4. Inspect locking set screws belowdeck for signs of loosening.
5. Use Tef-Gel on large diameter threads.
6. Use blue Loctite to secure locking set screws.
7. Note: the bail can be at any angle to the loading.

Load Direction – The position of the bail is not load direction sensitive. The bail can be at any direction to the load.

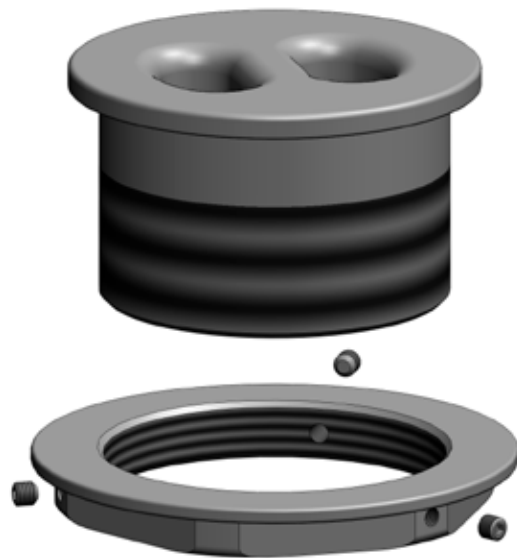

Perform long-term maintenance and inspection after prolonged use, before long-term storage, or if part has loosened.

Tools and supplies

Soapy water solution

Inspection and service

1. Refer to exploded view for sample disassembly.
2. Use soap and water to clean all parts. Rinse with fresh water.
3. Remove and inspect loop or lashing, especially at chafe points of loop against bail. Replace loop or lashing on a regular basis. Replace immediately if there are signs of chafe or deterioration.
4. Carefully inspect padeye bail for signs of wear, bending or deterioration. Replace part if any is found.
5. Inspect locking nuts for signs off loosening. Tighten as necessary.

Load Direction – The position of the bail is load-direction sensitive.

WARNING! Always make sure that loads are aligned with bail as shown.

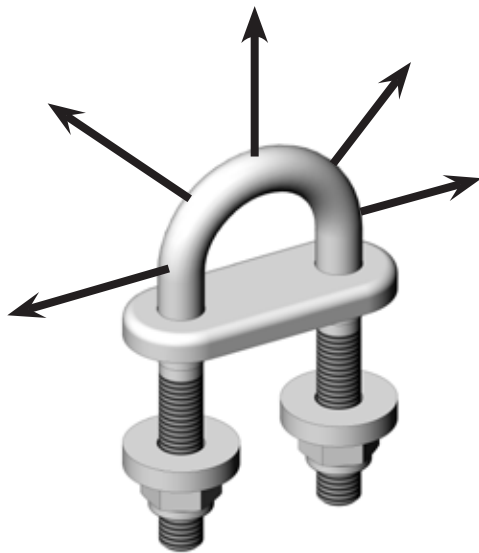

Correct



Incorrect

Perform long-term maintenance and inspection after prolonged use, before long-term storage, or if part has loosened.

Tools and supplies

Soapy water solution

Inspection and service

1. Refer to cutaway view for sample disassembly.
2. Use soap and water to clean all parts, especially the spring-pin mechanism. Rinse with fresh water.

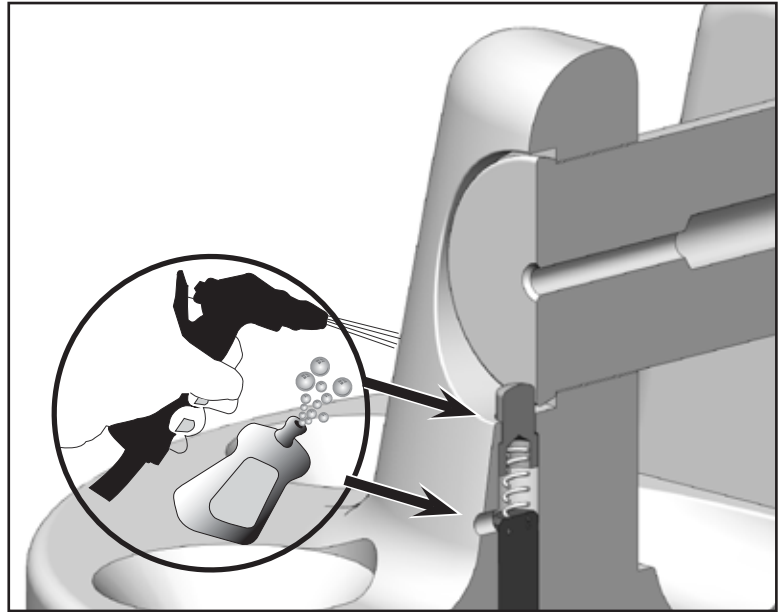

3. Remove and inspect toggles, pins and tangs for signs of wear, bending or deterioration. Replace part if any is found. Replace cotter pins upon disassembly.

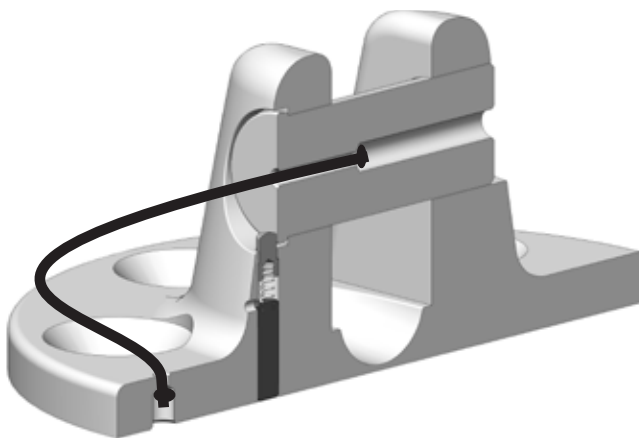

Load Direction – The position of the bail is load-direction sensitive.

WARNING! Always make sure that loads are perpendicular to the pin as shown.

Perform long-term maintenance and inspection after prolonged use, before long-term storage, or if part has loosened.

Tools and supplies

- Soapy water solution
- Tef-Gel® lubricant for stainless steel plugs

Inspection and service

1. Refer to exploded view for sample disassembly.
2. Use soap and water to clean all parts, especially the spring-pin mechanism. Rinse with fresh water.
3. Inspect screws and locking nuts for signs off loosening and tighten as necessary.

**Deck plug maintenance and replacement**

If deck plug is difficult to rotate, remove plug and clean threads. If plug is stainless steel, use Tef-Gel on threads. If deck plug is Delrin® plastic, clean parts only. Contact Harken to order replacement plug. Install plug so it is flush with top of bolt-down deck cup.



When installing removable top in deck cup, always start with deck plug flush with top of bolt-down deck cup.

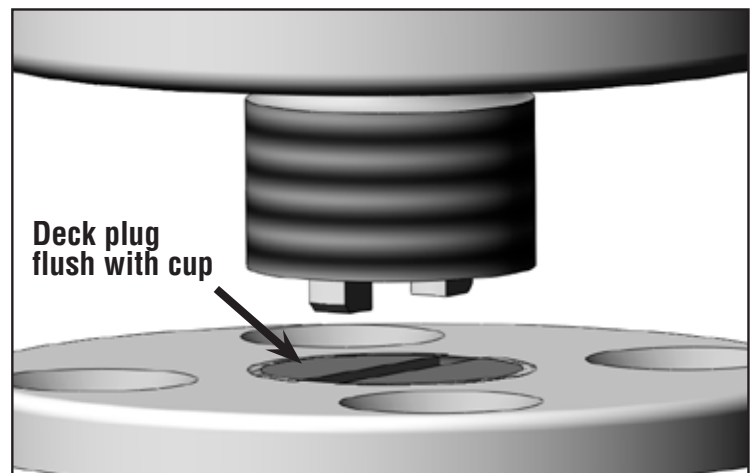

Tef-Gel is a registered trademark of Ultra Safety Systems.
Delrin is a registered trademark of E. I. du Pont de Nemours and Company or its affiliates.

Perform long-term maintenance and inspection after prolonged use, before long-term storage, or if part has loosened.

Tools and supplies

- Soapy water solution
- Tef-Gel® lubricant

Inspection and service

1. Refer to exploded view for sample disassembly.
2. Use soap and water to clean all parts. Rinse with fresh water. Thoroughly flush rotating components by immersing in warm soap and water solution and rotating.
3. Carefully inspect padeye bail for signs of wear, bending or deterioration. Replace part if any is found.
4. Use Tef-Gel on large diameter threads.

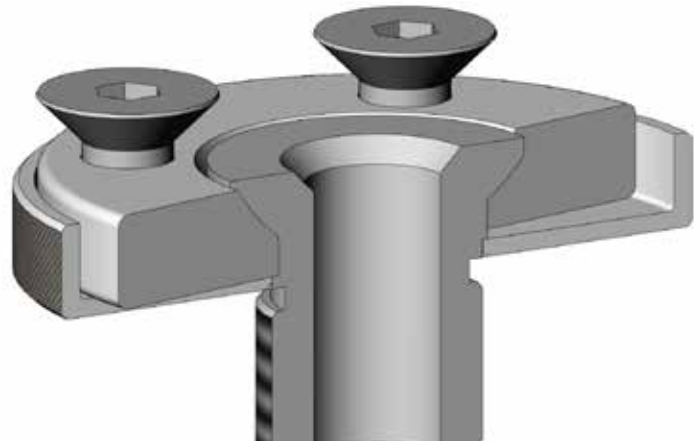

Installing swivel padeye in deck cup

Start with deck plug flush with top of bolt-down cup. When installing removable swivel top, make sure bottom of fitting is tight against top of bolt-down deck cup.



CORRECT

Top swivels so bail can align with load.



INCORRECT

Thread swivel bolt completely into deck cup so there is no gap.

Load Direction → – The position of padeye bail is load-direction sensitive; however, bail can align to load.

Perform long-term maintenance and inspection after prolonged use, before long-term storage, or if part has loosened.

Tools and supplies

- Soapy water solution
- Tef-Gel® lubricant

Inspection and service

1. Refer to exploded view for sample disassembly.
2. Use soap and water to clean all parts. Rinse with fresh water.
3. Carefully inspect padeye bail for signs of wear, bending or deterioration. Replace part if any is found.
4. Use Tef-Gel on large-diameter threads.

Installing in deck cup – Start with deck plug flush with top of bolt-down cup. The position of the bail is load direction sensitive. When installing a fixed, non-swiveling padeye, make sure padeye bail is aligned with load. The base of the padeye will likely not be tightened against the top of the bolt-down deck cup. Screw padeye top all the way down and back it off to align the bail with the load.

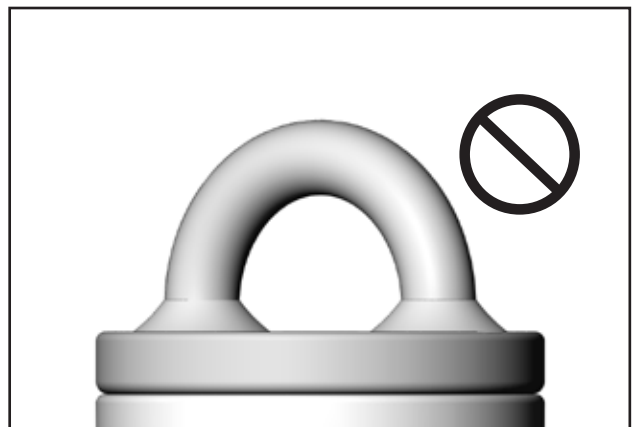
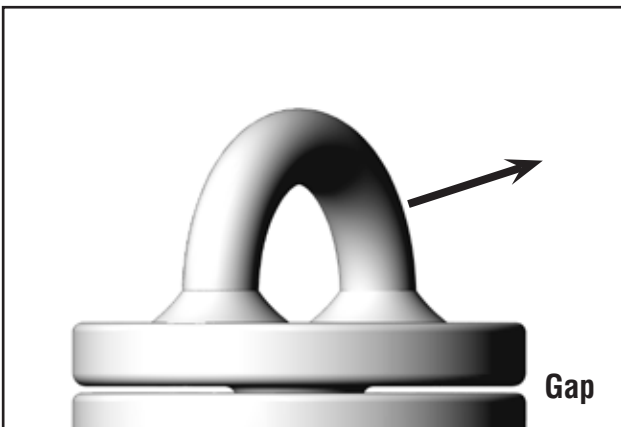
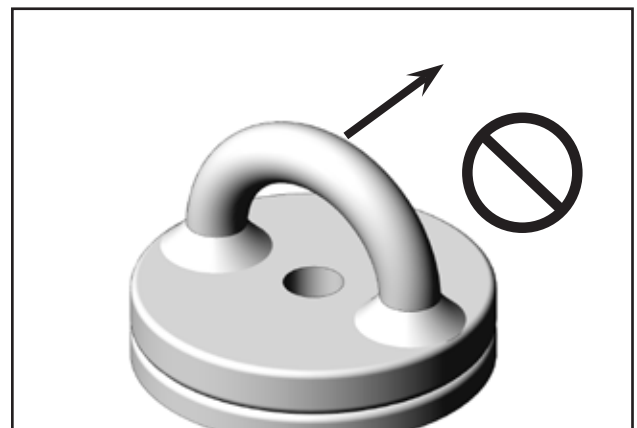
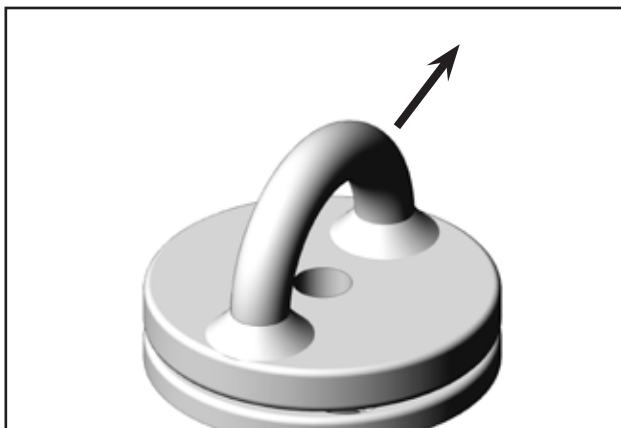

CORRECT
Top can swivel so bail can align with load

INCORRECT
Top is tight to base and cannot align with load

Load Direction - The position of the bail is load-direction sensitive.

WARNING! Always make sure that loads are applied in line with the padeye bail.

Perform long-term maintenance and inspection after prolonged use, before long-term storage, or if part has loosened.

Tools and supplies

- Hex key
- Soapy water solution
- Blue Loctite® adhesive
- Tef-Gel® lubricant

Inspection and service

1. Refer to exploded view for sample disassembly.
2. Use soap and water to clean all parts. Rinse with fresh water. Thoroughly flush center cavity.
3. Remove and inspect loop or lashing especially at chafe points of loop against bail. Replace loop or lashing on a regular basis. Replace immediately if there are signs of chafe or deterioration.
4. Inspect locking set screws for signs of loosening. If loose install using blue Loctite
5. Use Tef-Gel on large diameter threads.



Installing in deck cup - Start with deck plug flush with top of bolt-down cup. Make sure bottom of fitting is tight against top of bolt-down deck cup.

Load Direction - The position of the bail is not sensitive to load direction. The loop or lashing can be at any angle to the bail when loaded.

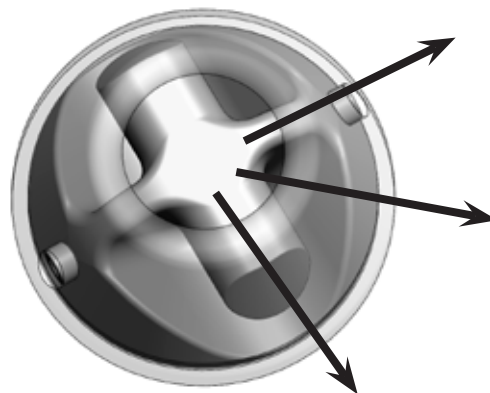

Loctite is a registered trademark of Henkel AG & Company KGaA.
Tef-Gel is a registered trademark of Ultra Safety Systems.

Perform long-term maintenance and inspection after prolonged use, before long-term storage, or if part has loosened.

Tools and supplies

Spanner wrench
Soapy water solution
Tef-Gel® lubricant

Inspection and service

1. Refer to cutaway view for sample cleaning areas.
2. Use spanner wrench to remove soft-attach swivel bail from deck cup.
3. Use soap and water to clean all parts. Rinse with fresh water. Thoroughly flush rotating components by immersing in warm soap and water solution and rotating.
4. Remove and inspect loop or lashing, especially at chafe points of loop against bail. Replace loop or lashing on a regular basis. Replace immediately if there are signs of chafe or deterioration.
5. Use Tef-Gel on large diameter threads.

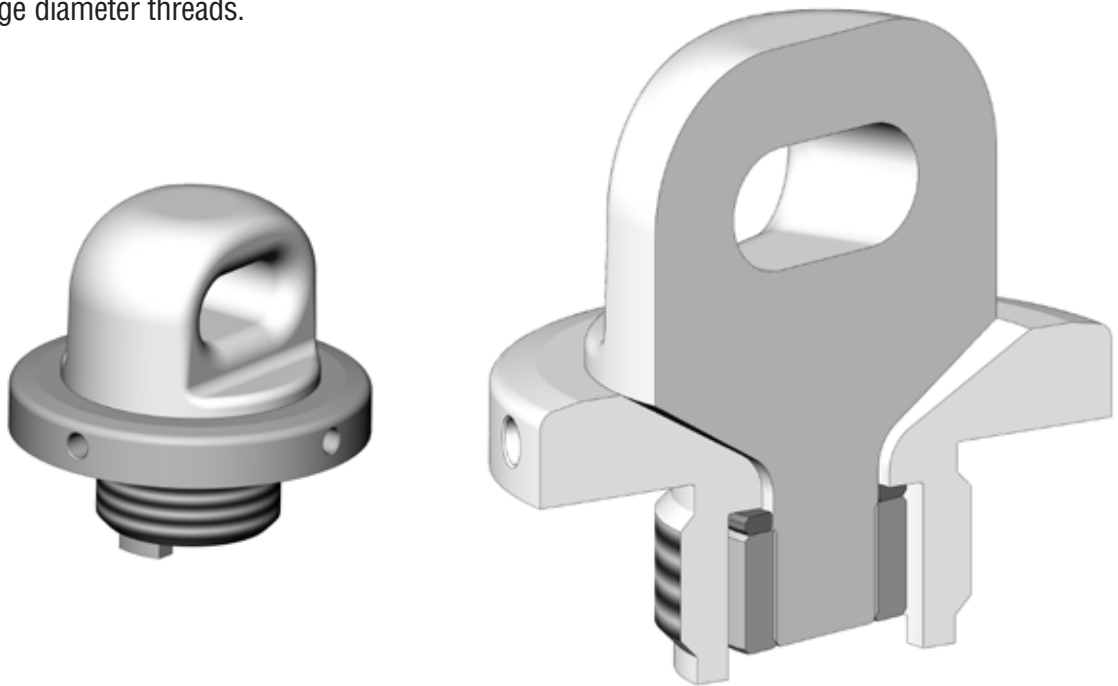

Installing in deck cup - Start with deck plug flush with top of bolt-down cup. Make sure bottom of fitting is tight against top of bolt-down deck cup.

Load Direction - The position of the bail is not sensitive to load direction. The loop or lashing can be at any angle to the bail when loaded.

Perform long-term maintenance and inspection after prolonged use, before long-term storage, or if part has loosened.

Tools and supplies

- Soapy water solution
- Tef-Gel® lubricant

Inspection and service

1. Refer to exploded view for sample disassembly.
2. Use soap and water to clean all parts especially spring-pin assembly. Rinse with fresh water.
3. Remove and inspect loop or lashing especially at chafe points of loop against bail. Replace loop or lashing on a regular basis. Replace immediately if there are signs of chafe or deterioration.
5. Use Tef-Gel on large diameter threads.

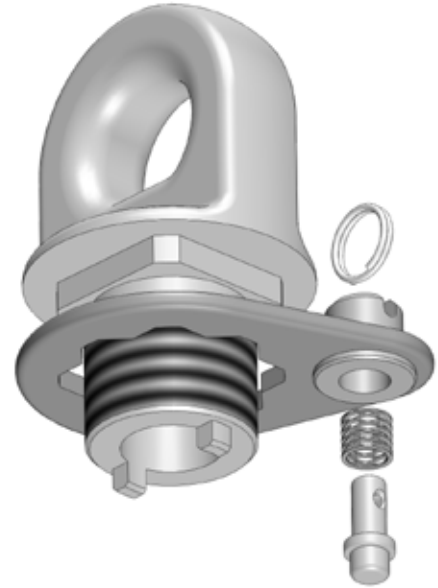

Installing in deck cup - Start with deck plug flush with top of bolt-down cup. Make sure that multi-position locking plate mates with the square on the main eyebolt. Choose the cutout that provides the desired bail orientation.

Load Direction - The position of the bail is not sensitive to load direction. The loop or lashing can be at any angle to the bail when loaded.

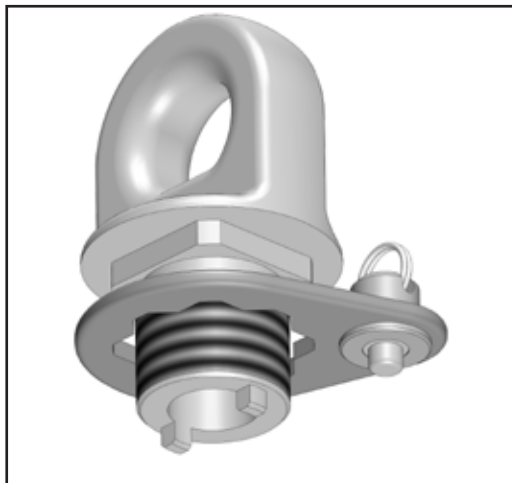

Make sure eye bolt is threaded completely into the deck cup so the spring-loaded pinstop inserts into the socket of the deck cup screw. Pull up on pinstop as eye bolt threads into deck cup.

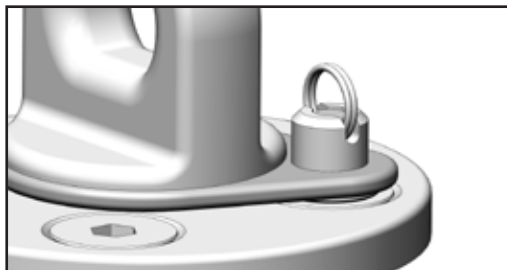

CORRECT
Pinstop inserts into screw socket

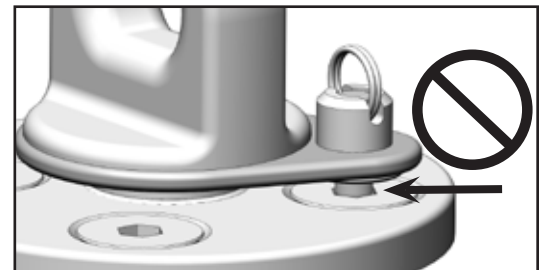

INCORRECT
Pinstop does not insert enough

Tef-Gel is a registered trademark of Ultra Safety Systems.

Perform long-term maintenance and inspection after prolonged use, before long-term storage, or if part has loosened.

Tools and supplies

- Soapy water solution
- Tef-Gel® lubricant
- Replacement cotter pins
- Spanner wrench

Inspection and service

1. Refer to exploded view for sample disassembly.
2. Remove and inspect toggles, pins and tangs for signs of wear, bending or deterioration. Replace part if any is found. Replace cotter pins upon disassembly.
3. Use soap and water to clean all parts. Rinse with fresh water. Thoroughly flush rotating components by immersing in warm soap and water solution and rotating.
4. Use Tef-Gel on large diameter threads.

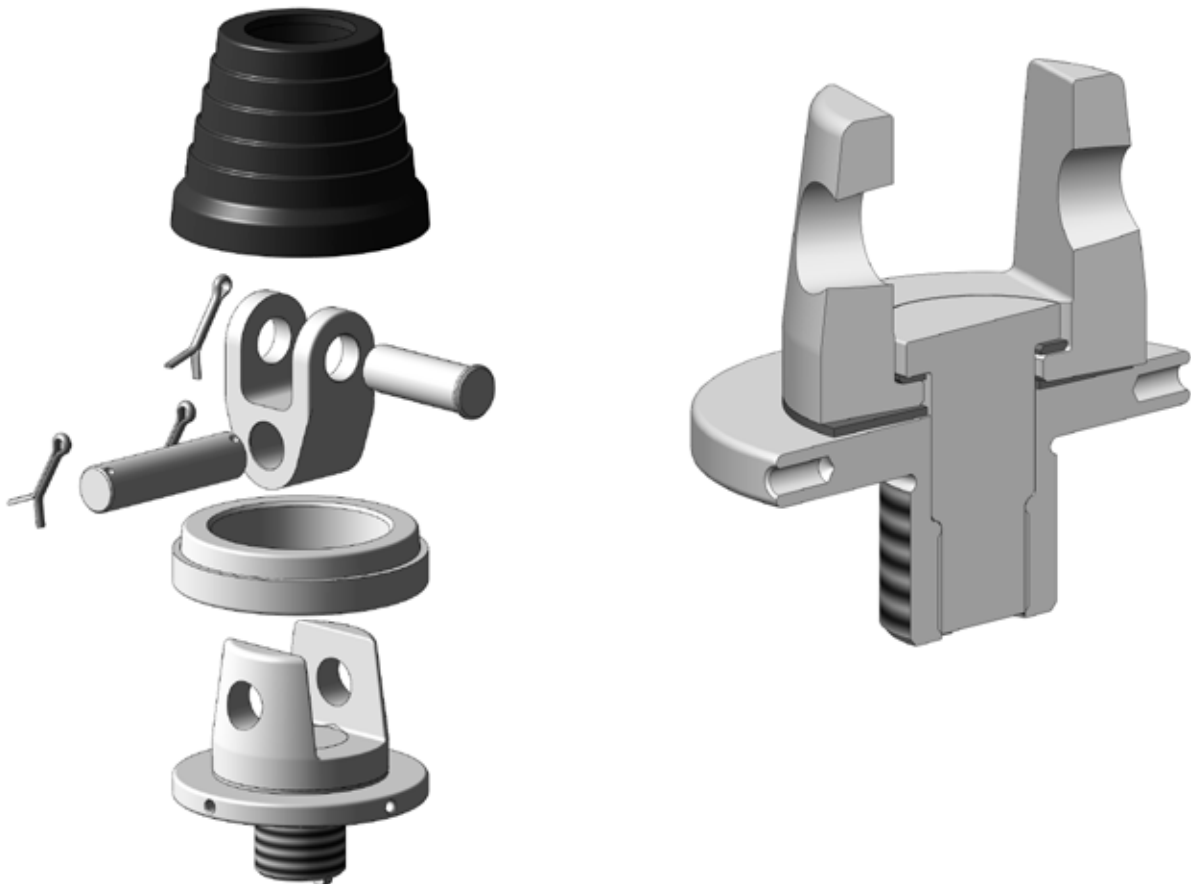

Installing in deck cup - Start with deck plug flush with top of bolt-down cup.

Load Direction - The position of the toggle assembly is not sensitive to load direction.

Perform long-term maintenance and inspection after prolonged use, before long-term storage, or if part has loosened.

Tools and supplies

- Soapy water solution
- Blue Loctite® adhesive
- Tef-Gel® lubricant
- Replacement cotter pins
- Spanner wrench

Inspection and service

1. Refer to exploded view for sample disassembly.
2. Remove and inspect toggles, pins and tangs for signs of wear, bending or deterioration. Replace part if any is found. Replace cotter pins upon disassembly.
3. Use soap and water to clean all parts. Rinse with fresh water. Thoroughly flush rotating components by immersing in warm soap and water solution and rotating.
4. Use blue Loctite on threaded set screws and flathead toggle locking screws.
5. Use Tef-Gel on large diameter threads.

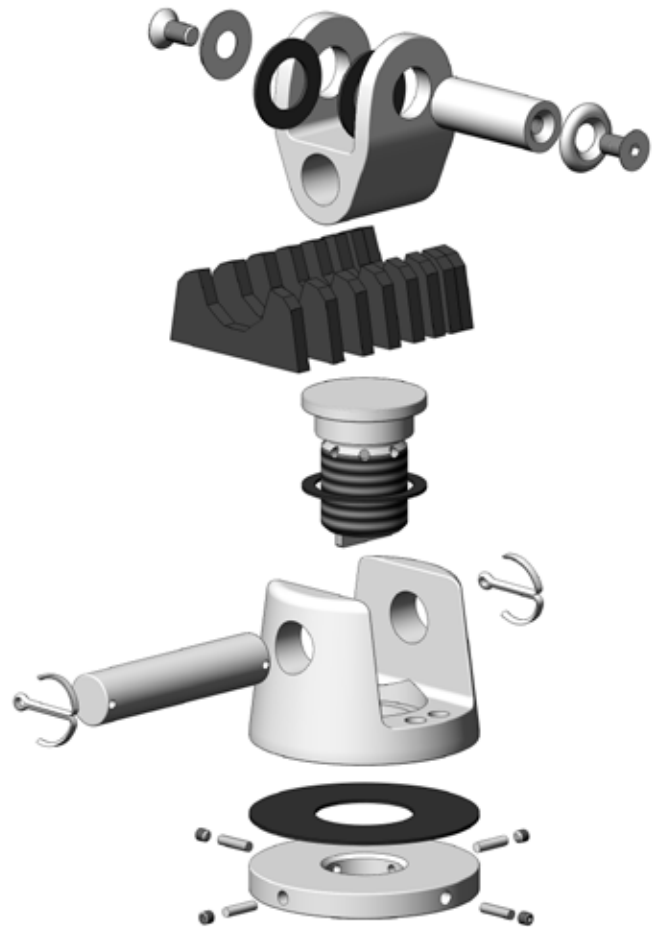

Installing in deck cup - Start with deck plug flush with top of bolt-down cup.

Load Direction - The position of the bail is not sensitive to load direction. The loop or lashing can be at any angle to the bail when loaded.

Perform long-term maintenance and inspection after prolonged use, before long-term storage, or if part has loosened.

Tools and supplies

- Soapy water solution
- Soapy water solution
- Purple Loctite® adhesive
- McLube® OneDrop™ ball conditioner

Order these parts and have on hand for long term service

- Screws - HFS1092 M4X.7X8MM Use A4 18-8
- Plastic roller retaining caps can wear and may need replacing

Inspection and service

1. Refer to exploded view for sample disassembly.
2. Remove and inspect toggles, pins, coupler plates, screws for signs of wear, bending, or deterioration. Replace part if any is found.
3. Remove and inspect loop or lashing especially at chafe points of loop against bail. Replace loop or lashing on a regular basis. Replace immediately if there are signs of chafe or deterioration.
4. Use soap and water to clean all parts. Rinse with fresh water.
5. Use **purple** Loctite on screws used to retain roller retaining caps. **IMPORTANT! Using red Loctite on roller retaining caps may be too hard to loosen and hex key may strip in socket.**
6. See Harken video showing how to load rollers.
7. Apply one (1) to two (2) drops of McLube OneDrop ball bearing conditioner to each roller race and circulate rollers to distribute.



Loctite is a registered trademark of Henkel AG & Company KGaA.
 McLube is a registered trademark of McGee® Industries, Inc.
 OneDrop is a trademark of McLube®, a Division of McGee Industries.

MAINTENANCE RECORD		
Product:		
Model/type	Description	Part number
Manufacturer HARKEN	Address N15W24983 Bluemound Rd Pewaukee, WI 53072-4974 USA	Tel/Fax/Email/Website (262) 691-3320 / (262) 701-5780 harken@harken.com / www.harken.com
Year of Manufacture	Purchase Date	Date First Put Into Use
Other important information (i.e. document number):		

EXAMINATION/REPAIR HISTORY				
Date	Reason for entry (periodic exam or repair)	Defect notes, repairs carried out, and other important information	Name and signature of competent person	Date of next periodic examination

Warranty
www.harken.com/manuals
or call, write, email or fax Harken, Inc.,
Pewaukee, WI USA

HARKEN®

Corporate Headquarters

N15W24983 Bluemound Rd, Pewaukee, WI 53072 USA
Telephone: (262) 691-3320 • Fax: (262) 701-5780
Web: www.harken.com • Email: harken@harken.com

Harken Australia Pty, Ltd.

1B Green Street, Brookvale, N.S.W. 2100, Australia
Telephone: (61) 2-8978-8666 • Fax: (61) 2-8978-8667
Web: harken.com.au • Email: info@harken.com.au

Harken France

ZA Port des Minimes, BP 3064, 17032 La Rochelle Cedex 1, France
Telephone: (33) 05.46.44.51.20 • Fax: (33) 05.46.44.25.70
Web: harken.fr • Email: info@harken.fr

Harken Italy S.p.A.

Via Marco Biagi, 14, 22070 Limido Comasco (CO) Italy
Telephone: (39) 031.3523511 • Fax: (39) 031.3520031
Web: harken.it • Email: info@harken.it

Harken New Zealand, Ltd.

158 Beaumont Street
Unit 11, Orams Marine Centre
Westhaven, Auckland, 1010, New Zealand
Telephone: (64) 9-303-3744 • Fax: (64) 9-307-7987
Web: harken.co.nz • Email: harken@harken.co.nz

Harken Polska Sp. z o.o.

ul. Przasnyska 6A, 01-756, Warszawa, Poland
Tel: +48 22 561 93 93 • Fax: +48 22 839 22 75
Web: harken.pl • Email: polska@harken.pl

Harken Sweden AB

Main Office and Harken Brandstore: Västmannagatan 81B
SE-113 26 Stockholm Sweden
Telephone: (46) 0303 61875 • Fax: (46) 0303 61876
Mailing address: Harken Sweden AB, Box 64, SE -440 30 Marstrand
Web: harken.se • Email: harken@harken.se

Harken UK, Ltd.

Bearing House, Ampress Lane, Lymington, Hampshire S041 8LW, England
Telephone: (44) 01590-689122 • Fax: (44) 01590-610274
Web: harken.co.uk • Email: enquiries@harken.co.uk

**Please visit: <http://www.harken.com/locator.aspx>
to locate Harken dealers and distributors**