

Installation and Maintenance Manual

MRW-02

Radial Winch 20 ST

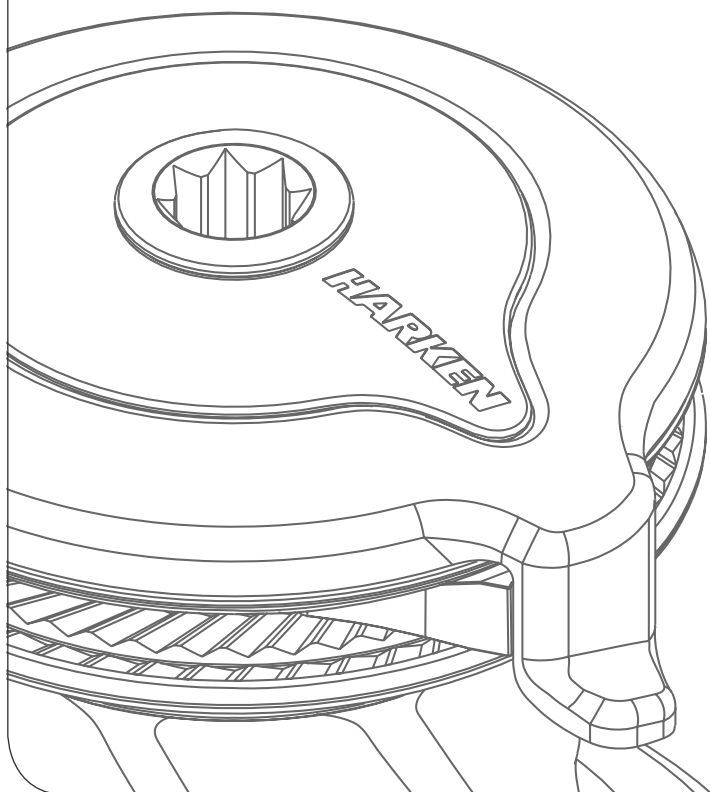

HARKEN[®]

Introduction	3
Technical characteristics	3
<i>Weights</i>	3
<i>Maximum working load</i>	3
Outline	3
Installation	4
<i>Procedure 1</i>	5
<i>Procedure 2</i>	6
<i>Installation procedure</i>	8
<i>Positioning the self-tailing arm</i>	9
Maintenance	9
<i>Washing</i>	9
<i>Maintenance table</i>	9
<i>Disassembly procedure</i>	9
<i>Exploded view with maintenance products</i>	12
<i>Assembly</i>	13
Harken® limited worldwide warranty	14
Ordering spare parts	14
Exploded view	15
Parts List	17
<i>Radial Winch 20 STA</i>	17
<i>Radial Winch 20 STC</i>	18
<i>Radial Winch 20 STCW</i>	19

Introduction

This manual gives technical information on winch installation and maintenance, including disassembling and reassembling.

This information is DESTINED EXCLUSIVELY for specialised personnel or expert users.

Installation, disassembling and reassembling of the winch by personnel who are not experts may cause serious damage to users and those in the vicinity of the winch.

Harken® accepts no responsibility for defective installation or reassembly of its winches.

In case of doubt the Harken® Tech Service is at your disposal at techservice@harken.it

This Manual is available only in English. If you do not fully understand the English language, do not carry out the operations described in this Manual.

Technical characteristics

	Power ratio	Gear ratio
1st speed	19,20 : 1	2,76 : 1

The theoretical power ratio does not take friction into account.

Weights

	ST A version	ST C version
Weight (Kg)	2,4	3,4

Versions: A = drum in anodised aluminium; C = drum in chromed bronze

Maximum working load



WARNING!

The maximum working load (MWL) for the 20 ST Radial Winch is 550 Kg (1213 lb)

Subjecting the winch to loads above the maximum working load can cause the winch to fail or pull off the deck suddenly and unexpectedly during high loads causing severe injury or death.

Outline

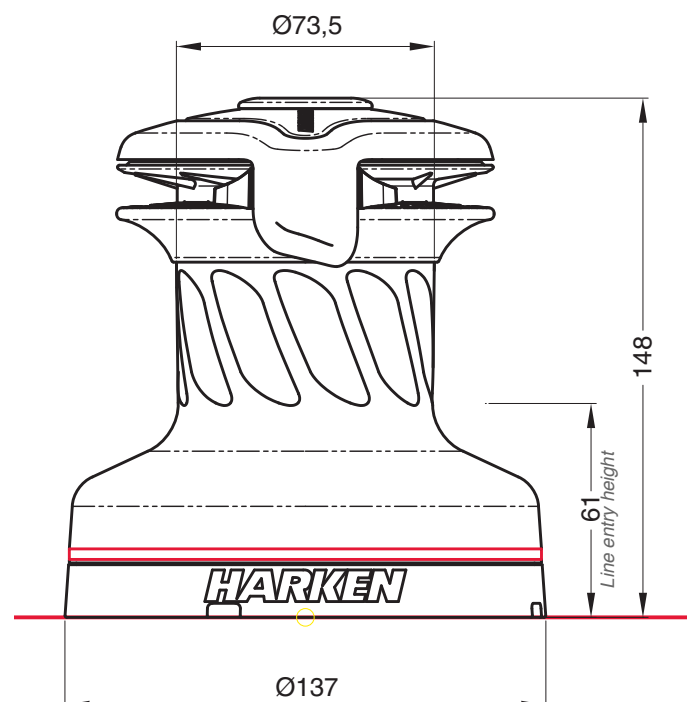

Installation

The winch must be installed on a flat area of the deck, reinforced if necessary to bear a load equal to at least twice the maximum working load of the winch.

It is the installer's responsibility to carry out all structural tests needed to ensure that the deck can bear the load.

Harken® does not supply the screws needed to install the winch since these may vary depending on the deck on which it is to be installed.

It is the installer's responsibility to choose the correct screws taking account of the loads they will have to bear.

Harken® assumes no responsibility for incorrect installation of its winches or for an incorrect choice of mounting screws.



DANGER!

Incorrect installation of the winch may cause severe injury or death. Consult the yard that built the boat in the case of doubt over the correct positioning of the winch.



WARNING!

Failure to use the correct number and type of mounting fasteners or failure to ensure the correct deck strength can result in the winch pulling off the deck suddenly and unexpectedly during high loads causing severe injury or death.



WARNING!

Verify the entry angle of the sheet. This must be 8° with tolerance of $\pm 2^\circ$, to avoid sheet overrides and damaging the winch or making the winch inoperable leading to loss of control of the boat which can lead to severe injury or death.

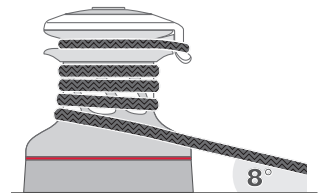

WARNING!

Mount the winch on the deck so that the drive gear is positioned where the sheet enters the winch drum. Incorrect position of drive gear can weaken winch leading to failure which can cause an accident leading to severe injury or death.

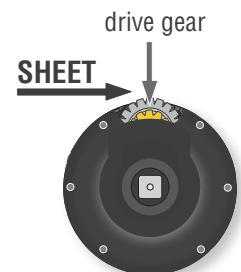

NOTICE

You can find the icon ▲ on the skirt to identify the drive gear position.



Once you have chosen the correct mounting position for the winch on the deck proceed with installation.

The winch can be installed following one of the two procedures below (**Procedure 1** or **Procedure 2**):

Procedure 1

To install the winch you must remove the drum and use Socket Head (SH) bolts.

Tools needed  One medium flat-bladed screwdriver

To identify the various parts, refer to the exploded view at the end of this Manual.

 Torque to apply when assembling



1. Unscrew the central screw ($\approx 2\text{Nm}/18\text{ in-lb}$)



2. Slide off the assy socket n°20 and the cover n°19



3. Unscrew the three screws n°18
($\approx 4\text{Nm}/35\text{ in-lb}$)



4. Remove the self-tailing arm n°17 by rotating and lifting it.



5. Lift off the drum n°13

Install the winch on the deck in the position you have chosen, keeping in mind the limits described on page 4 and using socket head (SH) bolts.

Procedure 2

To install, you must remove the winch skirt and use hexagonal headed bolts.

Tools needed  One medium flat-bladed screwdriver

To identify the various parts, refer to the exploded view at the end of this Manual.



1. Remove the skirt n°2 with the help of the screwdriver placed as shown by the symbol 



2. Take off the skirt n°2



3. Position the 5 M6 hexagonal headed bolts in their holes



4. Reposition the skirt n°2 in its housing



5. Press down the skirt to position it correctly

NOTICE

Make sure the skirt is correctly clipped on to the base of the winch.

Install the winch on the deck in the position you have chosen, keeping in mind the limits described on page 4 and using hexagonal headed bolts.
(See paragraph on installation)

Installation procedure

Carry out Procedure 1 or Procedure 2, then install the winch on the deck in the chosen position.

A. Position the base of the winch on the deck and mark the position of the holes or use the drilling cut-out template at the point where you have decided to place the winch.

Below is a reduced scale diagram.

The drilling cut out template is available on the Harken® website, www.harken.com

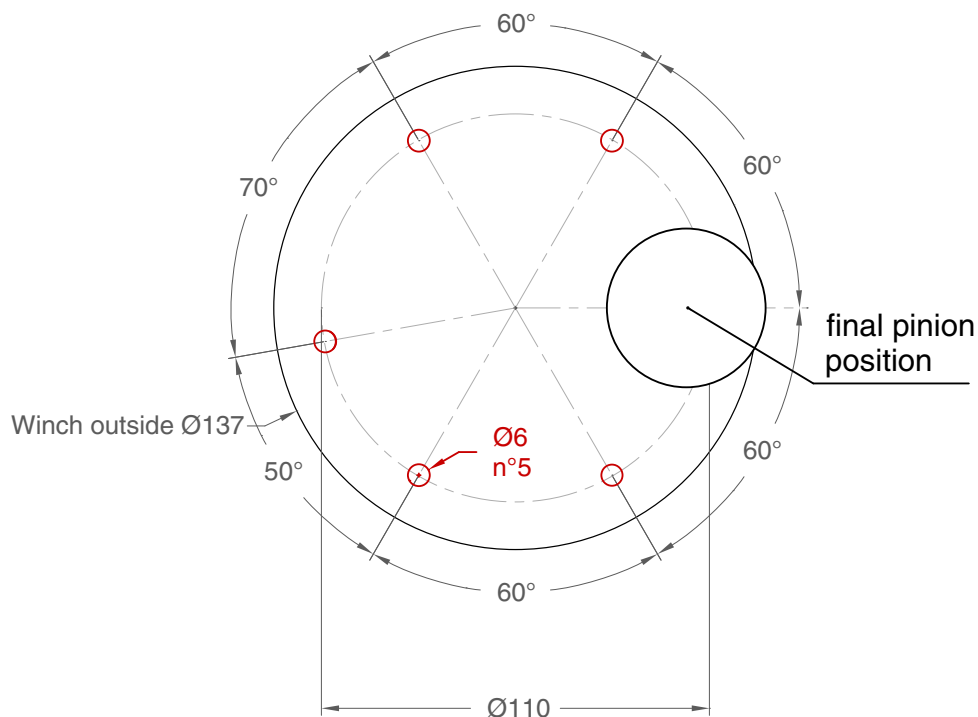

B. Remove the winch and drill the five 6.2 mm diameter holes.

C. Bolt the base of the winch to the deck using five M6 Socket Head (SH) bolts for Procedure 1 or five hexagonal headed M6 bolts for Procedure 2 (neither is supplied by Harken®), correctly chosen for the thickness and type of the boat deck. Consult the yard that built the boat in case of doubt.



WARNING!

To install the winch on the deck, use only bolts in A4 stainless steel (DIN 267 part11). Bolts made of other materials may not have sufficient strength or may corrode which can result in winch pulling off deck suddenly and unexpectedly during high loads causing severe injury or death.

NOTICE

To mount winches on the deck, do not use countersunk bolts.

D. Fill the mounting holes with a suitable marine sealant.

E. Remove the excess adhesive/sealant from the holes and base drainage channels

F. Reassemble the winch following the steps in **Procedure 1** or **Procedure 2** in the reverse order, and apply the products indicated in the section on maintenance.

NOTICE

Before closing the winch, make sure the holes and drainage channels in the base of the winch are not obstructed.

Positioning the self-tailing arm

Position the self-tailing arm so that the line leaving the winch is led into the cockpit.

MaintenanceWashing

Winches must be washed frequently with fresh water, and in any case after each use.

Do not allow teak cleaning products or other cleaners containing caustic solutions to come into contact with winches and especially anodised, chrome plated or plastic parts.

Do not use solvents, polishes or abrasive pastes on the logos or stickers on the winches. Do not use polishes or abrasive pastes on anodised, chromed plated or plastics surfaces.

Make sure that the holes and drainage channels in the base of the winch are not obstructed so that water does not collect.

Maintenance table

Winches must be visually inspected at the beginning and end of every season of sailing or racing. In addition they must be completely overhauled, cleaned and lubricated at least every 12 months. After an inspection, replace worn or damaged components. Do not replace or modify any part of the winch with a part that is not original.

**WARNING!**

Periodic maintenance must be carried out regularly. Lack of adequate maintenance shortens the life of the winch, can cause serious injury and also invalidate the winch warranty. Installation and maintenance of winches must be carried out exclusively by specialized personnel.

In the case of doubt contact Harken® Tech Service at techservice@harken.it

Disassembly procedure

Tools needed



One medium flat-bladed screwdriver



A number five hex key

Rags

To identify the various parts refer to the exploded view at the end of this Manual.

 Torque to be applied in assembly phase

Carry out **Procedure 1** as shown in the paragraph on winch installation and then do the following:



6. Completely unscrew the three screws n°18



7. Remove the self-tailing arm support n°12 and slide out the bushing



8. Slide out the central shaft n°7



9. Remove the pin n°6



10. Slide off gear n°3



11. Slide off gear n°11

If it is necessary to replace any **jaws** of the winch, proceed as follows:



I. Unscrew the 3 screws n°16
($\approx 4\text{Nm}/35\text{ in-lb}$)



II. Remove the jaws n°15

If it is necessary to remove any pawls in the central shaft, proceed as follows:



Unscrew the screw n°10 and remove the
washer n°9 ($\approx 4\text{Nm}/35\text{ in-lb}$)

Once the winch is completely disassembled, clean the parts: use a basin of diesel oil to soak metal components and rinse plastic parts in fresh water. Once you have done this, dry the parts with cloths that do not leave residue.

Inspect gears, bearings, pins and pawls for any signs of wear or corrosion.

Carefully check the teeth of gears and ring gears to make sure there are no traces of wear.

Replace worn or damaged components.

Carry out maintenance on components using the products listed below.

For more information on which products to use where, refer to the exploded diagram below.

Use a brush to lightly lubricate all gears, gear pins, teeth and all moving parts with grease. Lightly lubricate the pawls and springs with oil. Do not use grease on the pawls!

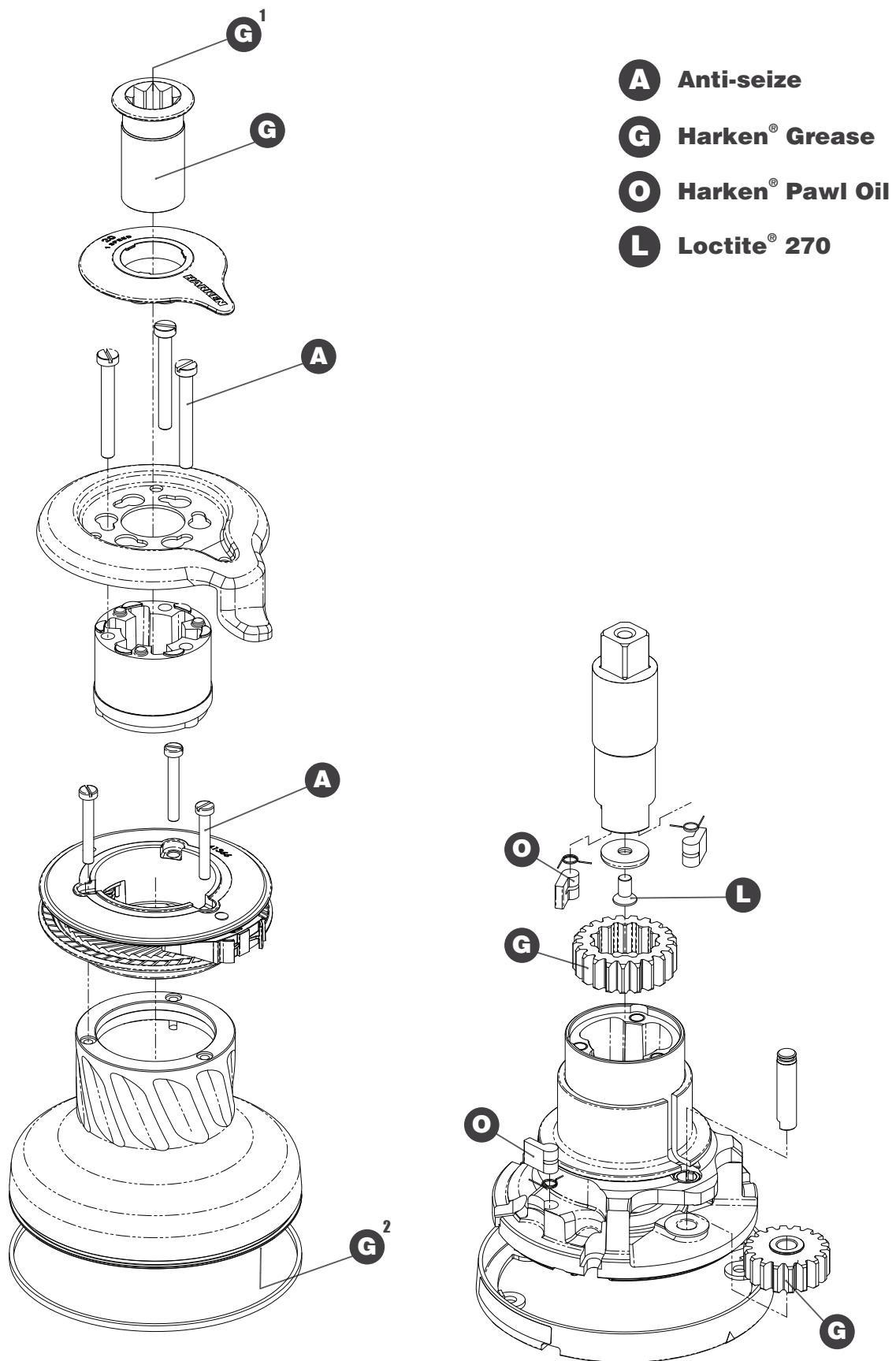
Exploded view with maintenance products

1. Apply Harken® grease on assy socket screw - 2. Apply Harken® grease on drum gear

Assembly

Make sure that the holes and drainage channels in the base of the winch are not obstructed
 Assemble the winch in the reverse order of the sequence in the section on disassembly.

To tighten bolts, use the torque indicated in the disassembly procedure.



When positioning the stripper arm, align the peeler with it.

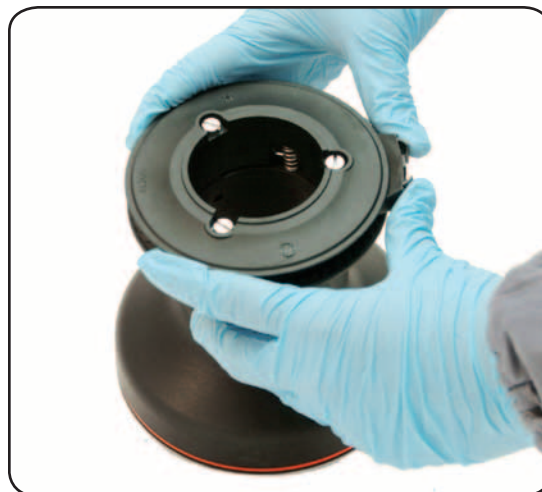

If the jaws have been disassembled, insert peeler between the two jaws, taking care that the letters TOP on the peeler are facing upwards.

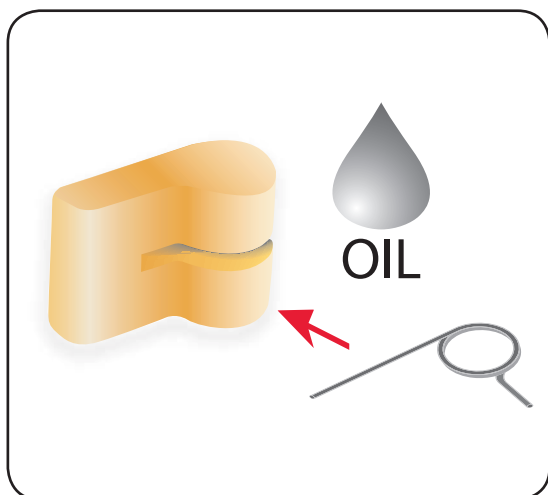

To assemble the pawls

Correctly position the spring in its housing as shown at left. Hold the spring closed and slide the pawl into its housing. Once in position, check that the pawls can be easily opened and closed with a finger.

In case of doubt concerning the assembly procedure contact Harken® Tech Service:
techservice@harken.it

Harken® limited worldwide warranty

Refer to the Harken® Limited Worldwide Warranty in the Harken® Catalogue and on the website www.harken.com

Ordering spare parts

Spare parts can be requested from Harken® as described in the Harken® Limited Worldwide Warranty, indicating the part number in the Parts List and including the serial number of the winch for which the parts are required.

The serial number of the winch is printed on a plate on the drum support of the winch.

**Manufacturer*****Harken® Italy S.p.A.***

Via Marco Biagi, 14
22070 Limido Comasco (CO) Italy
Tel: (+39) 031.3523511
Fax: (+39) 031.3520031
Email: info@harken.it
Web: www.harken.com

- **Tech Service**
Email: techservice@harken.it
- **Customer Service**
Tel: (+39) 031.3523511
Email: info@harken.it

Headquarters***Harken®, Inc.***

1251 East Wisconsin Avenue
Pewaukee, Wisconsin 53072-3755 USA
Tel: (262) 691.3320
Fax: (262) 691.3008
Email: harken@harken.com
Web: www.harken.com

- **Tech Service**
Email: technicalservice@harken.com
- **Customer Service**
Tel: (262) 691-3320
Email: customerservice@harken.com

Exploded view

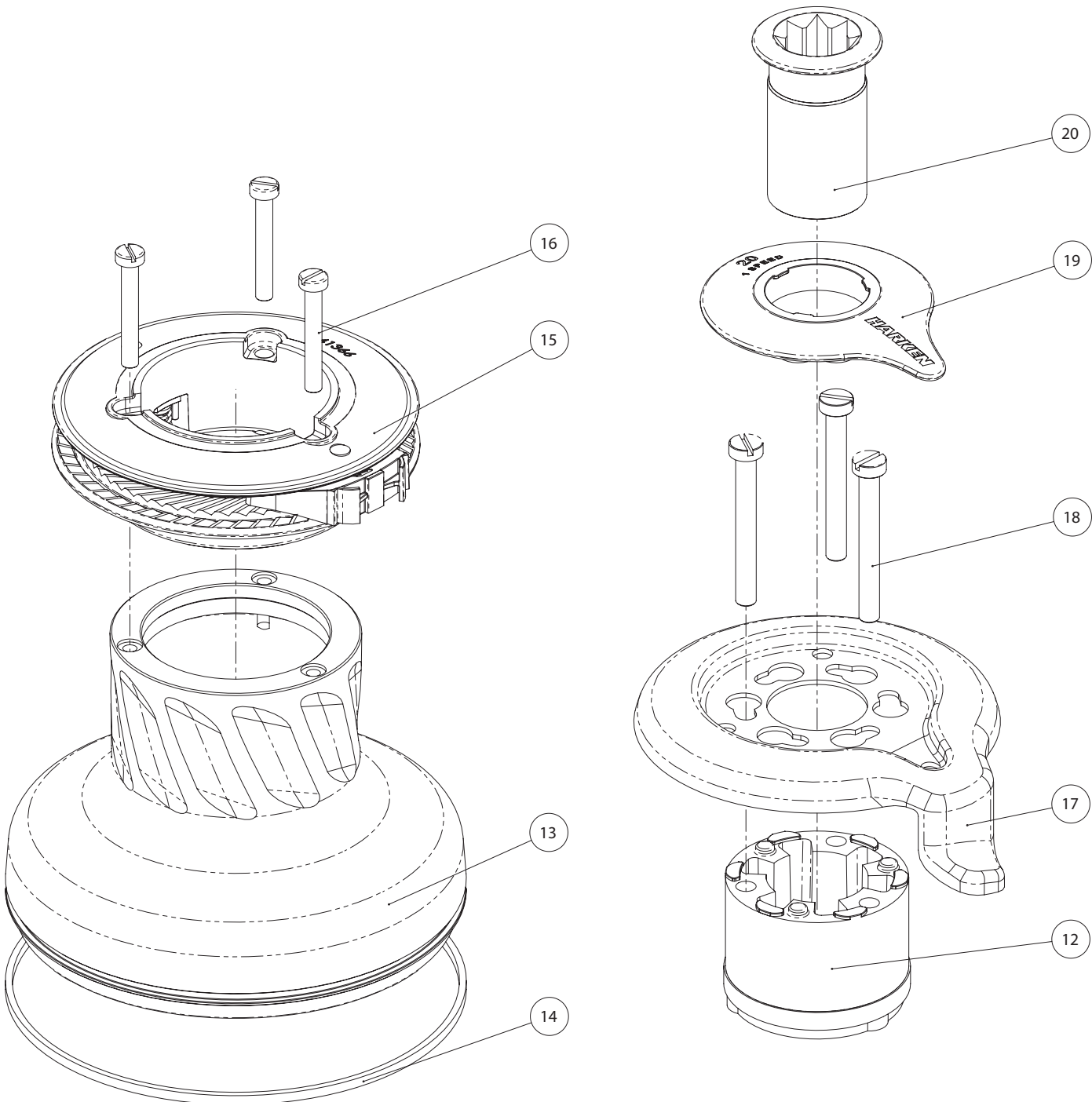

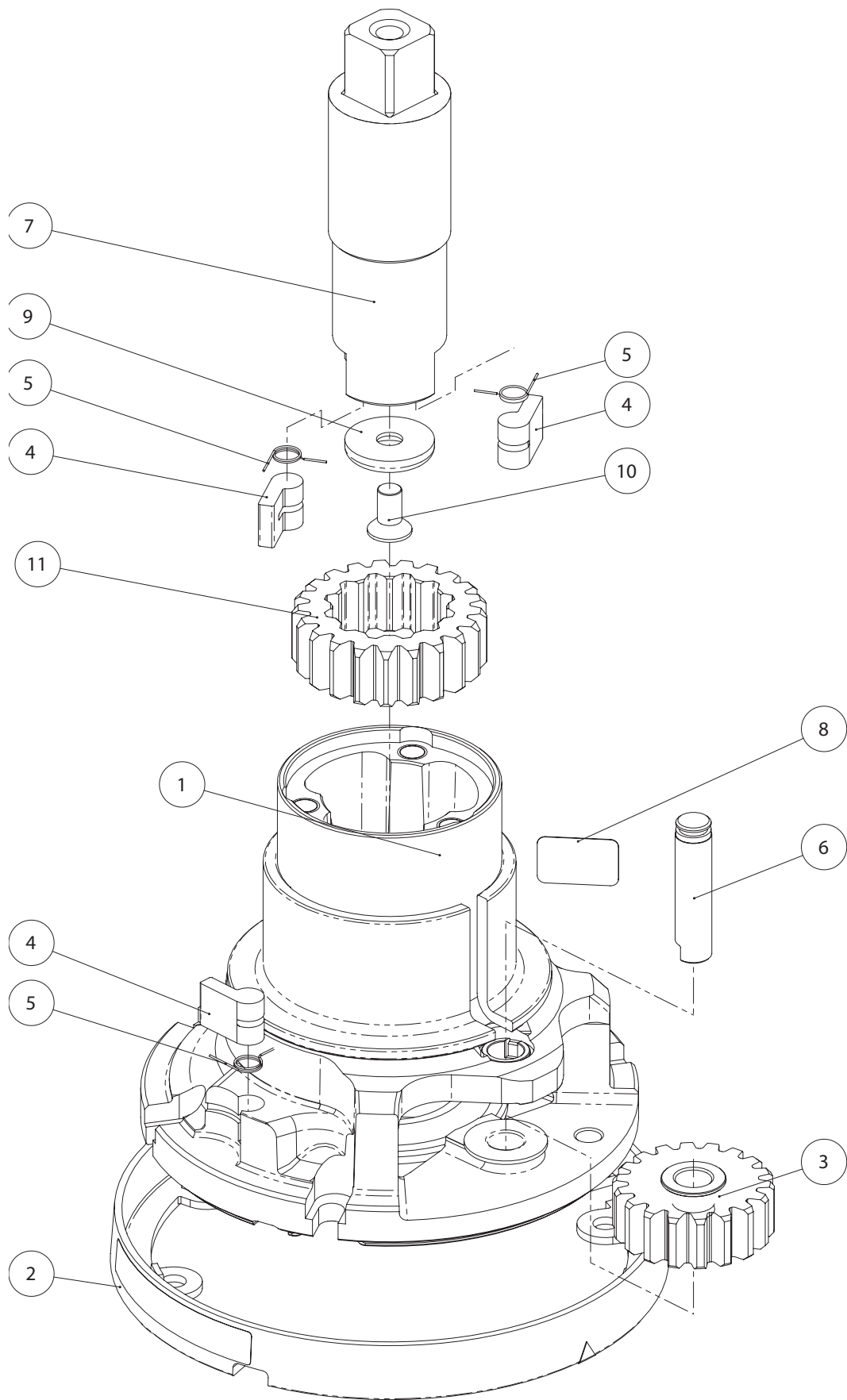

Parts List

Radial Winch 20 STA

A= drum in anodised aluminium

Pos.	Q.ty	Code	Description
1	1	A 941369 00	Assy Housing Winch 20 Housing W20 Bushing Ø9xØ11x9* Bushing Ø9xØ11x12* Heli-coil M6x9 Bushing Ø55xØ62x34* Washer Ø33.5xØ58x5.5 Bushing Ø28xØ33x25*
2	1	A 941386 00	Assy Skirt Winch 20 Skirt W20 Winch Product Sticker**
3	1	A 941367 00	Assy Gear Z18 Gear Z18 Bushing Ø9xØ11x7*
4	4	S 00008 00 03	Pawl Ø8*
5	4	S 00038 00 01	Pawl Spring Ø8*
6	1	S 41370 00 04	Pin
7	1	S 41363 00 02	Shaft Winch 20
8	1	S 41876 00 63	Winch Serial Number Sticker
9	1	S268890080	Washer
10	1	M 06040 03	Screw M6x12 UNI 5933*
11	1	S 41362 00 41	Gear Z21
12	1	S 41294 00 A0	Stripper arm support
13	1	S 41356 00 53	Drum W20
14	1	S 28167 00 97	Red line*
15	1	A 941365 00	Assy Jaws W20 Lower Jaw W20 Upper Jaw W20 Peeler W20 Spring
16	3	M6009103	Screw UNI EN ISO 1207:1996 - M5x35 - A4*
17	1	S 41357 00 19	Stripper Arm W20
18	3	M6007103	Screw M6x50 UNI6107*
19	1	S 41358 00 A5	Cover 1 Speed W20
20	1	A94136400	Socket Assy W20 Socket Handle W20 Washer Ø7.7xØ25x5.8 Screw M8x20 UNI 6109*

*Service kit available; see winch kit section on the website www.harken.com

**Winch product sticker



Radial Winch 20 STC

C=drum in chromed bronze

Pos.	Q.ty	Code	Description
1	1	A 941369 00	Assy Housing Winch 20 Housing W20 Bushing Ø9xØ11x9* Bushing Ø9xØ11x12* Heli-coil M6x9 Bushing Ø55xØ62x34* Washer Ø33.5xØ58x5.5 Bushing Ø28xØ33x25*
2	1	A 941386 00	Assy Skirt Winch 20 Skirt W20 Winch Product Sticker**
3	1	A 941367 00	Assy Gear Z18 Gear Z18 Bushing Ø9xØ11x7*
4	4	S 00008 00 03	Pawl Ø8*
5	4	S 00038 00 01	Pawl Spring Ø8*
6	1	S 41370 00 04	Pin
7	1	S 41363 00 02	Shaft Winch 20
8	1	S 41876 00 63	Winch Serial Number Sticker
9	1	S268890080	Washer
10	1	M 06040 03	Screw M6x12 UNI 5933*
11	1	S 41362 00 41	Gear Z21
12	1	S 41294 00 A0	Stripper arm support
13	1	S 41355 00 43	Drum C W20
14	1	S 28167 00 97	Red line*
15	1	A 941365 00	Assy Jaws W20 Lower Jaw W20 Upper Jaw W20 Peeler W20 Spring
16	3	M6009103	Screw UNI EN ISO 1207:1996 - M5x35 - A4*
17	1	S 41357 00 19	Stripper Arm W20
18	3	M6007103	Screw M6x50 UNI6107*
19	1	S 41358 00 A5	Cover 1 Speed W20
20	1	A94136400	Socket Assy W20 Socket Handle W20 Washer Ø7.7xØ25x5.8 Screw M8x20 UNI 6109*

*Service kit available; see winch kit section on the website www.harken.com

**Winch product sticker



Radial Winch 20 STCW

C=drum in chromed bronze - W=components RAL 9003

Pos.	Q.ty	Code	Description
1	1	A 941369 00	Assy Housing Winch 20 Housing W20 Bushing Ø9xØ11x9* Bushing Ø9xØ11x12* Heli-coil M6x9 Bushing Ø55xØ62x34* Washer Ø33.5xØ58x5.5 Bushing Ø28xØ33x25*
2	1	A 941386 00 W	Assy Skirt Winch 20 RAL 9003 Skirt W20 RAL 9003 Winch Product Sticker**
3	1	A 941367 00	Assy Gear Z18 Gear Z18 Bushing Ø9xØ11x7*
4	4	S 00008 00 03	Pawl Ø8*
5	4	S 00038 00 01	Pawl Spring Ø8*
6	1	S 41370 00 04	Pin
7	1	S 41363 00 02	Shaft Winch 20
8	1	S 41876 00 63	Winch Serial Number Sticker
9	1	S268890080	Washer
10	1	M 06040 03	Screw M6x12 UNI 5933*
11	1	S 41362 00 41	Gear Z21
12	1	S 41294 00 A0	Stripper arm support
13	1	S 41355 00 43	Drum C W20
14	1	S 28167 00 97	Red line*
15	1	A 941365 00 W	Assy Jaws W20 RAL 9003 Lower Jaw W20 RAL 9003 Upper Jaw W20 RAL 9003 Peeler W20 RAL 9003 Spring
16	3	M6009103	Screw UNI EN ISO 1207:1996 - M5x35 - A4*
17	1	S 41357 00 19	Stripper Arm W20
18	3	M6007103	Screw M6x50 UNI6107*
19	1	S 41358 00 A5 W	Cover 1 Speed W20 RAL 9003
20	1	A94136400	Socket Assy W20 Socket Handle W20 Washer Ø7.7xØ25x5.8 Screw M8x20 UNI 6109*

*Service kit available; see winch kit section on the website www.harken.com

**Winch product sticker

