



GOPOWERBIKE

GoFalcon Owner's Manual



WWW.GOPOWERBIKE.COM



DO NOT RETURN TO STORE!

If you need any help with your new **GoFalcon** bike, whether it is missing parts or you need help with assembly, please email us at Help@gopowerbike.com. We will be sure to respond!

Welcome

Thank you for purchasing the **GoFalcon** from GoPowerBike.

We take pride in bringing you a quality product that will offer years of enjoyment. Please read and understand this manual fully before assembling and riding your bike.

If you have any questions after reading this manual, please reference the GoPowerBike Help Center or contact us by email. **We are here to help!**

Email: help@gopowerbike.com

Website: www.gopowerbike.com



Table of Contents

Using This Manual	1
General Info	2
Safety Check	3
Getting Started	6
Installing the Front Wheel	7
Installing the Handlebar	11
Installing the Pedals	12
Installing the Front Fender & Headlight	14
Installing the Seat	16
Charging Your Ebike	17
Get To Know Your Ebike	18
Battery and Charging	19
Riding Your Ebike	20
Maintenance	21
Disclaimer & General Warnings	22
Limited Warranty	23
Additional Warranty Terms	24



Using This Manual

This manual contains details of the product, its equipment, and information on operation, maintenance, and other helpful tips for owners. Read it carefully and familiarize yourself with the ebike before using it to ensure safe use and prevent accidents. This manual contains many warnings and cautions concerning the safe operation and consequences if proper setup, operation, and maintenance are not performed. All information in this manual should be carefully reviewed and if you have any questions you should contact GoPowerbike immediately.

The notes, warnings, and cautions contained within the manual and marked by the triangular Caution Symbol should be given special care. Users should also pay special attention to information marked in this manual beginning with **NOTICE**.



Keep this manual, along with any other documents that were included with your bike, for future reference, however all content in this manual is subject to change or withdrawal without notice. GoPowerbike makes every effort to ensure the accuracy of its documentation and assumes no responsibility or liability if any errors or inaccuracies appear within.

Assembly and first adjustment of your bike from GoPowerbike requires special tools and skills and it is recommended that this should be done by a certified, reputable bike mechanic if possible.

Because it is impossible to anticipate every situation or condition that can occur while riding, this manual makes no representations about the safe use of bikes under all conditions. There are risks associated with the use of any bike that cannot be predicted or avoided and are the sole responsibility of the rider.

General Info

Assembly and Fit

Correct assembly and fit are essential elements of ensuring your bicycling safety, performance, and comfort. Even if you have the experience, skill, and tools to complete these essential steps before your first ride, GoPowerbike recommends having a certified, reputable bike mechanic check your work.

NOTICE: If you do not have the experience, skill, and tools to complete assembly and fit, GoPowerbike highly recommends having a certified, reputable bike mechanic complete these procedures as well as any future adjustments or tuning.

NOTICE: A critical aspect of assembling your bike by GoPowerbike is securing the front wheel and checking the tightness of the rear wheel axle nuts. All bikes by GoPowerbike use a quick release front wheel mounting mechanism and the rear wheel is bolted on. These mechanisms may become loose or unsecured during shipment or over time. The torque and security of all wheel mounting hardware should be inspected upon arrival and on a regular basis. Both wheels need to be properly secured before operating your bike.

Mandatory Equipment and Use Locations

Before all rides, ensure you have all required and recommended safety equipment and are following all laws pertaining to using an electric bike in your region. For example, these laws may specify the need for mandatory equipment, use of hand signals, and where you can ride.

Changing Components or Attaching Accessories

The use of non-original components or spare parts can jeopardize the safety of your ebike, invalidate your warranty and, in some cases, cause your ebike to not conform with laws pertaining to your bike.

Safety Check Before Each Ride

Always check the condition of your bike before you ride, in addition to having regular maintenance performed. If you are unsure of how to conduct a complete check of the condition of your bike before every ride, you should consult a certified, reputable bike mechanic for assistance. See the Pre-Ride Safety Checklist for more information.

Electrical System

The electrical system on your ebike offers various levels of power assistance and lighting for different operating conditions and user preferences. It is critical that you familiarize yourself with all aspects of your ebike's electrical system and check to see that it is working correctly before every ride. The front and rear brake levers contain safety power cutoff switches, which disable the hub motor's assistance when applied, and both levers should be checked for correct operation. The throttle should provide smooth acceleration when gradually applied. If the throttle, brake lever cutoff switches, pedal assistance, or lighting are functioning abnormally, intermittently, or not working, please discontinue using your ebike immediately and contact the GoPowerbike Product Support team for assistance.

Quick Release Levers

Quick release levers are located on your ebike to secure the seat post. These provide convenience to the user since they allow the seat post to be adjusted without tools. Since quick release levers can be loosened during transportation, or accidentally between or during rides, it is important that you regularly check to ensure these components are properly secured.

Accessories, Straps, and Hardware

Ensure all hardware is secured and all approved accessories are properly attached per the specific component manufacturer's instructions. It is good practice to look over all hardware, straps, and accessories before each ride, and if you do discover something wrong or find something you are not sure about, have it checked by a certified, reputable bike mechanic.

Handlebars, Grips, and Seat Adjustments

Ensure the handlebar and handlebar stem are properly aligned, fitted to the user, and secured to their recommended torque values. Handlebar grips should not move easily on the handlebar end. Loose, worn, or damaged handlebar grips should be replaced before you ride and can be purchased from GoPowerbike. The seat and seat post should be properly aligned, fitted to the user, and the seat post quick release should be properly tightened, fully closed, and secured before riding.

Battery Charged, Secured, and Unplugged

Ensure the battery is adequately charged and operating properly. Ensure the battery charger is unplugged from the outlet and battery, then stored in a safe location before you ride. Do not operate the electrical system if the battery is removed.

Fully Assembled GoFalcon



Getting Started

Starting notes:

- Remove all packaging before beginning assembly.
- The directions given in this manual—right, left, front/forward, and rear/back—are oriented as the rider would see them when seated on the bike. The “right side” of the bike, for example, is the side where the rider’s right hand and foot will be.

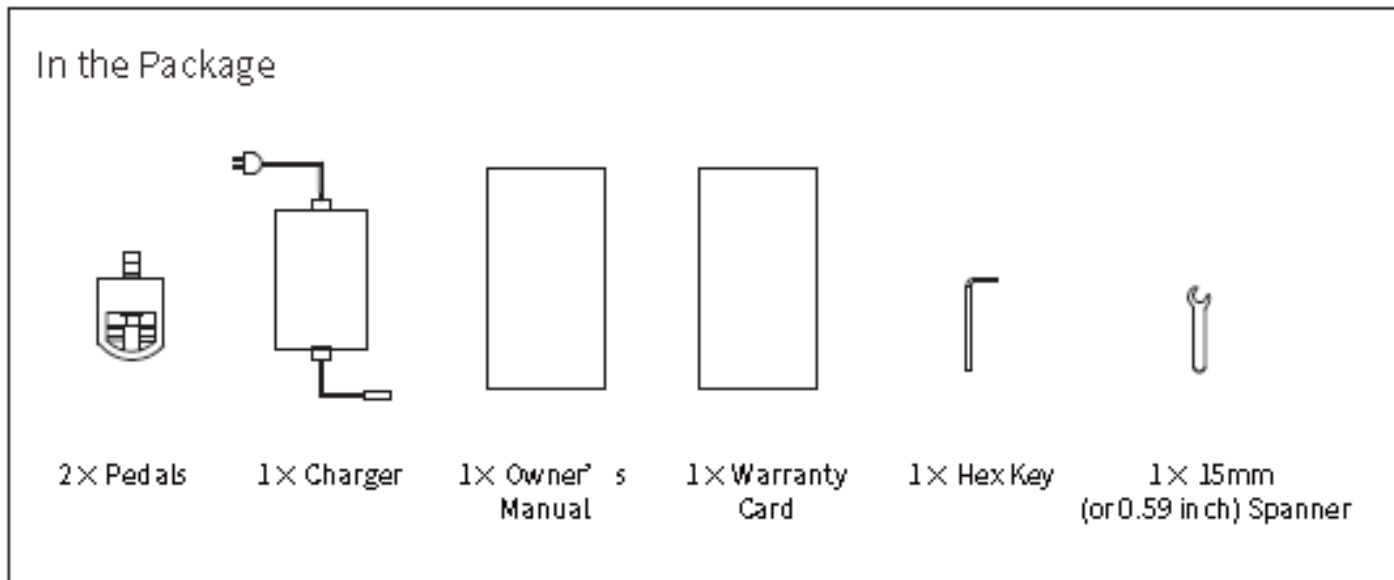

Installing the Front Wheel

Step 1: Gently balance the bike on the front fork and back wheel. (you may want a friend to help)

Step 2: Check that all packing materials are removed from the wheel and front fork. Remove the fork protector and protective film from inside the brake caliper.

Step 3: Twist the knob on the quick release axle counter-clockwise to loosen and remove it. Rer



Step 4: Locate the side of the front wheel with the disc. Insert the end of the quick release axle through the hole in the center of the wheel on the side OPPOSITE the disc and push it through to the disc side.

Step 5: Make sure to replace spring "A" in the same direction as it was removed. Slide the spring back onto the end of the axle so that the smaller side of the spring is closer to the wheel. (see picture above)

Step 6: Gently twist the knob clockwise onto the end of the axle but DO NOT fully tighten it.

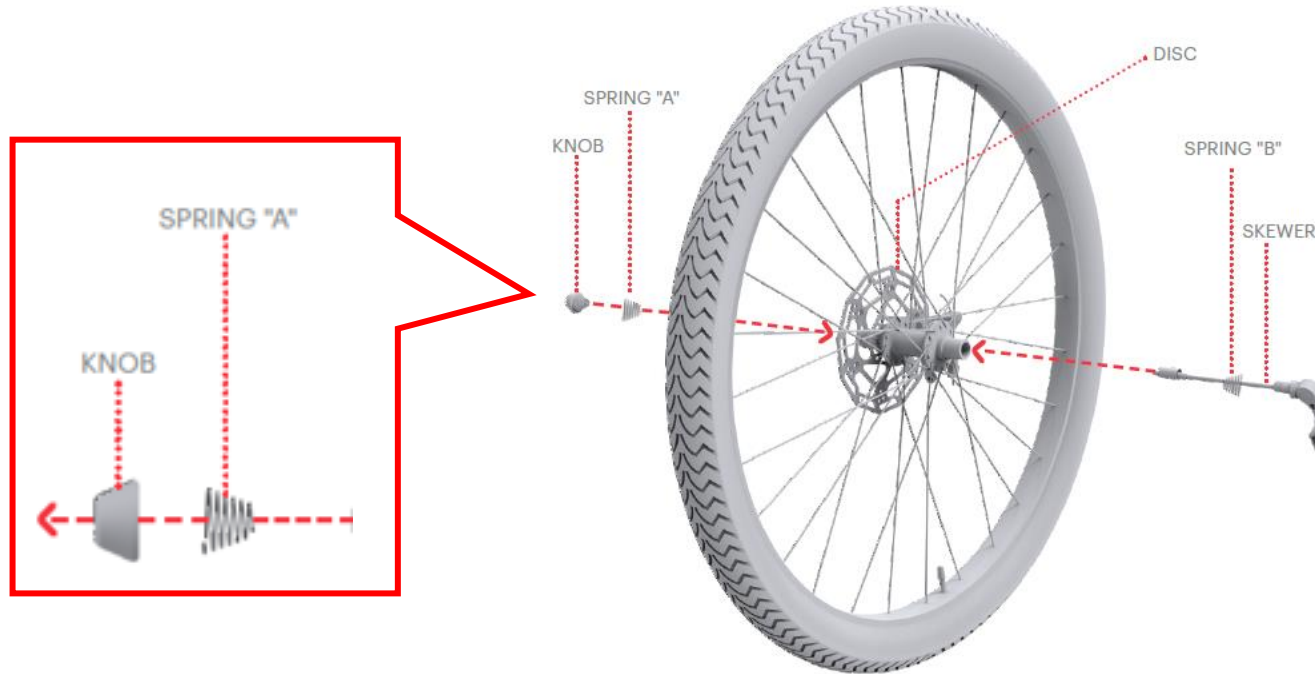

Step 7: Position the front wheel in between the front fork so that the disc side of the wheel is on the side of the fork with the brake components.

Step 8: Slide the wheel down into place with the disc in between the brake pads and the two springs on the axle situated in the notches at the end of the fork.

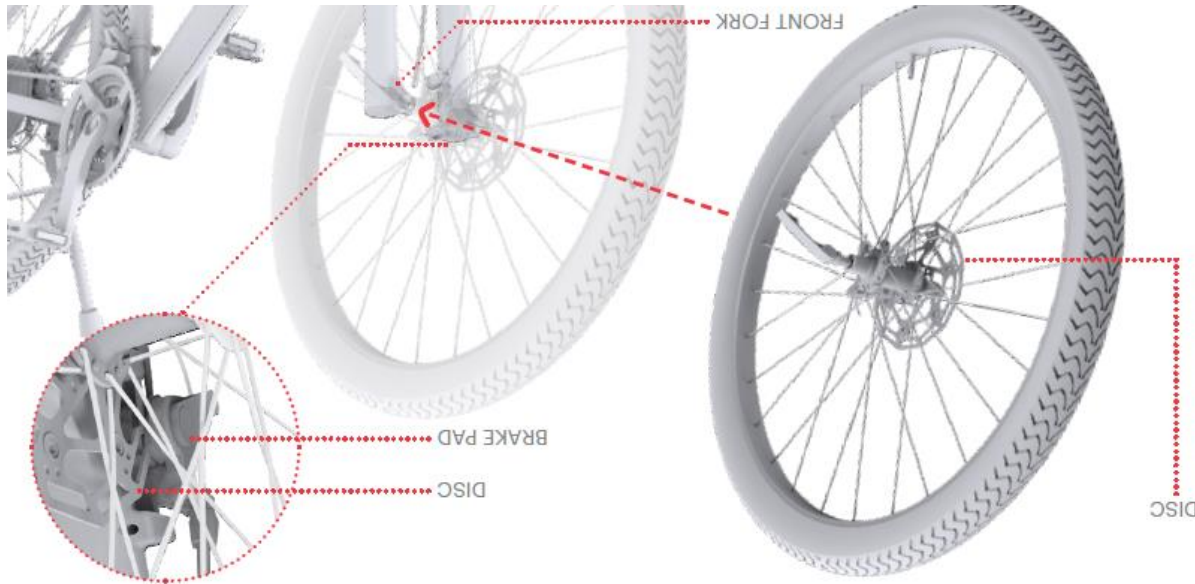

Step 9: When the wheel is centered and in place, tighten the knob on the axle by turning it clockwise. Close the latch on the quick release axle.

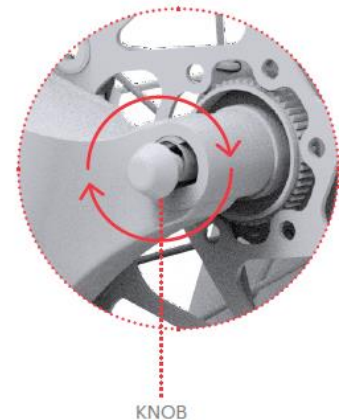

NOTICE! Ensure that the wheel is securely clamped onto the front fork with the axle. If the axle is properly tightened, closing the axle latch should be met with some resistance at the beginning and then require forceful effort to fully close. An unsecured wheel can loosen or fall off, putting the rider at risk for serious injury.

Step 10: Check that the wheel spins freely and is secured in place in the fork.



Troubleshooting: If you cannot open or close the latch on the quick-release axle, loosen the knob little by little until you can do so. Do not over-loosen. You should feel some tension when opening and closing the latch.

Installing the Handlebar

Step 1: Insert the handlebar into the stem and align it properly

Step 2: Remove the cover and 4 screws and set them aside



Step 3: Raise the handlebar into place and adjust it to the desired angle

Step 4: Replace the cover and screws and tighten them securely

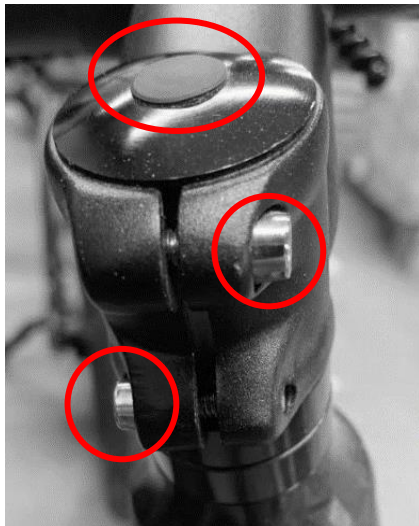

Step 5: After the handlebars are installed, make sure they are aligned with the front tire and carefully tighten the top screw under the rubber cover and the pinch bolts on each side of the stem.

Installing the Pedals

Note the “R” (right) and “L” (left) markings on the spindle end of each pedal.

Step 1: Align the spindle on “R” pedal with the hole at the end of the crank arm on the right side of the bike.

Step 2: Hold the pedal base steady and, taking care that the spindle enters the hole straight on, use your other hand to twist the spindle **CLOCKWISE** into the hole for a few rotations.

Caution: if you feel resistance when inserting the pedals into the holes on the crank arm, the spindle could be entering at an angle instead of straight on. Remove the pedal and realign it with the hole before making another attempt.

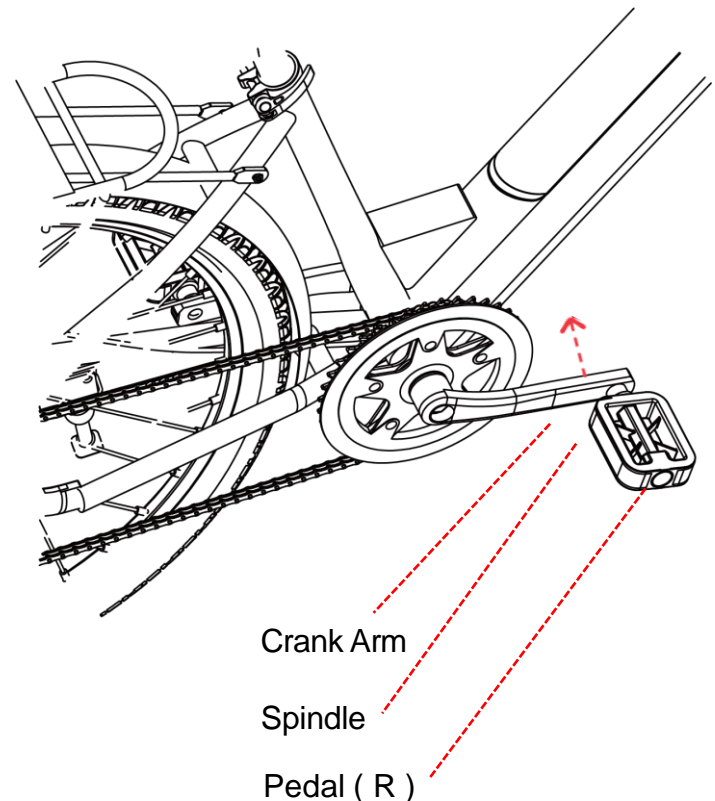

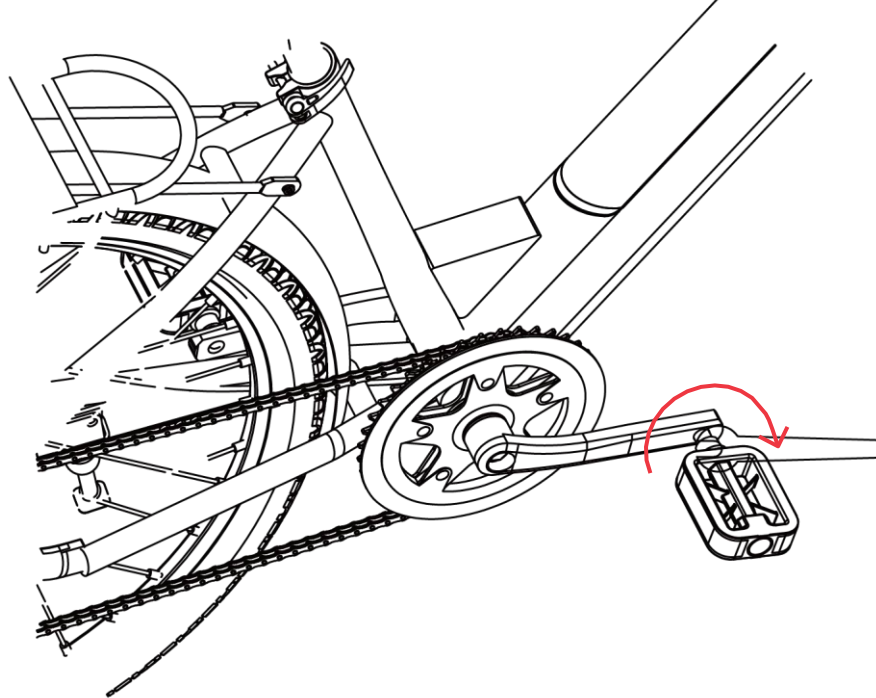

Step 3: Finish inserting and then tightening the spindle into the crank arm by turning it **CLOCKWISE**

Step 4: Check that the right pedal is secure.

Step 5: Repeat steps 2 – 5 with the left ("L") pedal tightening in the **COUNTER-CLOCKWISE** direction



NOTICE - the spindle on the left pedal is reverse threaded and needs to be inserted and tightened with counterclockwise turns.



Installing the Front Fender and Headlight

Step 1: Loosen the screw at the top of the fork and set aside



Step 2: Remove the two screws in the tabs located on the backside of the forks.



Step 3: Slide the fender, from front to back, into place until the tab at the top of the fender reaches the top of the fork. While positioning the fender, carefully squeeze the fender bracket so that it slides through the forks.

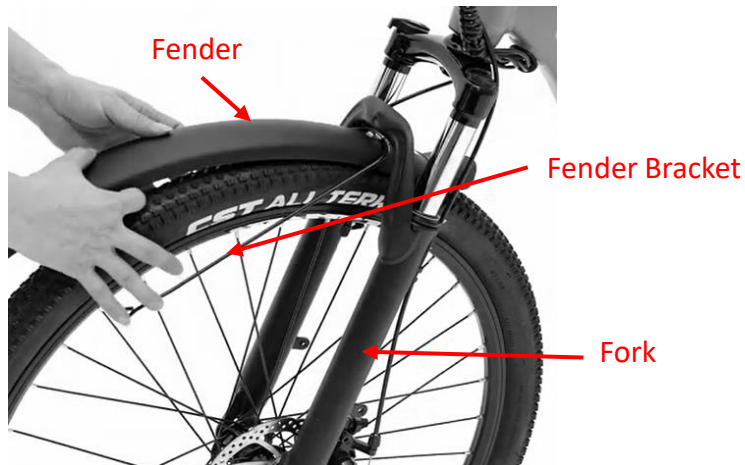

Step 4: Position the headlight bracket between the fork and fender tab. Insert screw that was previously removed and tighten. Adjust the headlight into the proper position.



Step 5: Align the fender bracket to the tabs on the fork and tighten the previously removed screws with an Allen key.

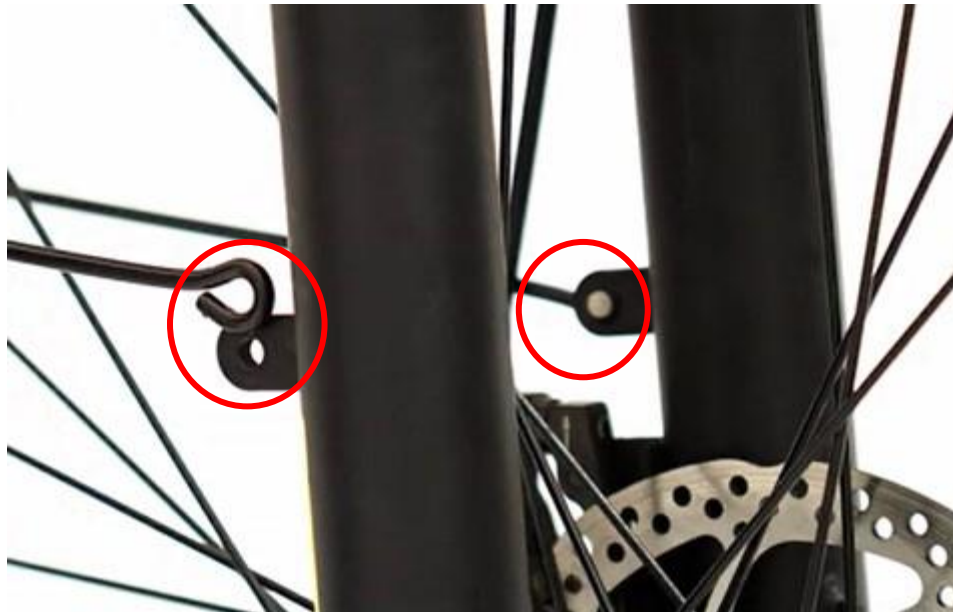

Installing the Seat

Step 1: Loosen the seat clamp on the seat tube.



Step 2: Insert the seat post into the seat stem and close the seat clamp.



NOTICE - Please be sure to check that the seat is secure before riding your bike.

Charging Your Ebike

Connect the DC jack of the charger to the charging port of your ebike and then the AC plug into the outlet. The charger light turns from red to green when charging is complete.

- ----- Still Charging
- ----- Fully Charged

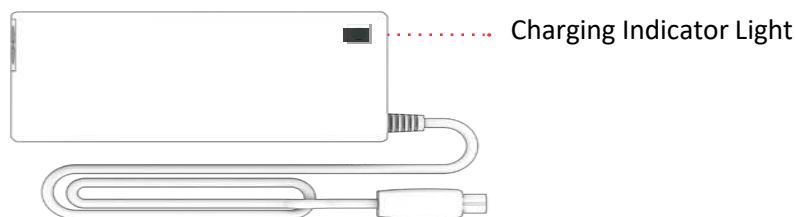

NOTICE - Important charging notes:

- Only use the included charger.
- Always keep the charging port closed when not actively charging your bike.
- Never turn on your bike while it is charging.
- For best battery health, charge the battery fully during each charging session.
- Never leave your bike charging overnight or for extended periods of time.
- Do not attempt to remove or disassemble the battery.

Get to Know Your Ebike-Operation

Power On/Off: Press and hold the power button on the left handle for 5 seconds to turn your bike on and off

Lights On/Off: Locate the light switch below the display on the right handle. Press and hold the “+” button for 3 seconds to turn the light on/off.

Pedal Assist mode: On the left handle, locate the buttons marked with “+” and “-” below the display. Press the buttons to change the mode. Mode 1/2/3 corresponds to the pedal assist maximum speed of 9.32mph (15 km/h), 15.53mph (25 km/h), and 19.88mph (32km/h). There is no pedal assist level “0”.

Riding Modes: Sports Mode-power off, and there is no motor output. Throttle Mode-power on, twist throttle to accelerate without pedaling. Pedal Assist Mode-power on , motor provides assistance for an easier ride. **Throttle will always go at maximum speed regardless of the pedal assist level.**

Power Cut-Off Brakes: When you pull the brake levers, the controller cuts off the motor output and the mechanical disc brakes are engaged.

Battery and Charging

- Do not connect the positive to negative, or vice versa. Do not damage, disassemble, or short-circuit the battery. Avoid water, other liquid, or other foreign matter inside the battery to prevent short circuit.
- Instructions in this manual must be followed when charging the battery, otherwise the owner shall take sole responsibility for any consequences.
- Charge the battery only at the temperature between 0° and 45°, and discharge at -20°~ 60°. The charging current should not exceed 2A. Charge only in a wellventilated area, away from sun and heat.
- Use the original charger from the package to charge the battery. Connect the charger and battery before plugging the charger into the mains. Do not charge the battery for over 6 hours each time.
- When charging, if the charging indicator appears abnormal, a smell is released, or the charger overheats, stop charging immediately. Service or replace the charger.
- To stop charging, unplug from the mains before disconnecting the charger and battery.
- When the charging indicator turns green, stop charging.
- Do not leave the charger connected to any AC power source when not charging.
- When not in use, store the battery in a dry and cool place. Keep away from rain, fire, heat and high temperature. Do not put the battery in acid or alkaline liquid. Make sure to charge the battery for two hours each month.
- Before using the charger to charge a different battery, note the battery type and voltage that the charger may apply to.
- It is advisable not to carry the charger with your eBike. If you must, place the charger in a toolbox upon shock absorption treatment.
- Do not disassemble the charger or replace the parts and components in the charger on your own.
- Waste battery is classified as hazardous. Do not disassemble the waste battery on your own. It should be collected and recycled properly.

Riding your ebike

1. Do not use the eBike before reading this manual carefully and knowing your eBike thoroughly.
2. Do not lend your eBike to anyone who do not know how to use it, so as to avoid harm.
3. When adjusting the steerer tube and seat tube, do not expose the minimum insertion marks.
4. Before riding, check the tire pressure. It is advisable to maintain at 35-45 PSI.
5. Before riding, ensure the power, lights, handles, brakes, wheels, reflectors and others are in good condition.
6. Before carrying people or objects on your eBike, learn the local laws and regulations, and abide by them.
7. Do not exceed the load capacity of 120 kg (or 265 lbs.).
8. Wear a helmet, and obey traffic rules.
9. Obey local traffic rules to keep to the right or left.
- 10. Do NOT ride one-handed.**
11. Do not ride on any motorized lane or in any pedestrian crowd.
12. It is advisable not to go over 15 km/h (or 9.32 mph) when riding on any non-motorized lane, downhill, or paved road.
13. Slow down in rain or snow as required braking distances increase.
14. It is advisable not to ride in storms or any extreme weather.
15. Avoid impact on the motor.
16. Keep the bearings lubricated.
17. Do not park your eBike in any lobby, walkway, evacuation stairway, or emergency entrance/exit.
18. Do not charge or park your eBike inside any residential building. Keep away from combustibles when charging. Charging should not exceed 6 hours each time.

Maintenance

1. The front and rear wheels should be aligned to the center of the front fork and frame.
2. Park away from direct sunlight and rain.
3. Do not rinse the eBike. Wipe with a damp cloth to clean.
4. Check the motor and brakes frequently. Do not oil the braking system.
5. Regularly check all screws and keep them fastened.
6. Recommended torque specs: handlebar screw 60-80 kgf.cm (or 52.08-69.44 lbf.in), steering stem screw 175-200 kgf.cm (or 151.90-173.60 lbf.in), saddle screw 175-250 kgf.cm (or 151.90-217.00 lbf.in), and wheel screw 320-450 kgf.cm (or 277.70-390.60 lbf.in).
7. Regularly check the tension of the chain, which can be adjusted via the chain regulator.
8. Frequently check the tires for scratches, cracks or excessive wear. The inner tube and valve should be perpendicular to the wheel hub. Punctured, damaged or excessively worn inner tube and tire must be replaced immediately. Please contact professional technicians.
9. It is forbidden to modify key structural parts including the frame, front fork and steering stem, and any electrical parts. If damaged, replace with identical parts from our factory. Otherwise, the warranty shall be void and the owner shall take sole responsibility for any consequence.

Disclaimer

1. Our company reserves the right to modify and give final interpretation to the product model, specification, and other information contained in this manual.
2. The product model, specification, and other information contained in this manual is subject to any modification or change without notice.
3. The functions of the specific model referred to in this manual apply to this specific model only.
4. Without the prior written permission of the company, the contents of the manual may not be copied, modified, reprinted, disseminated or published in any form.
5. Please read this manual carefully before using the product, and operate in accordance with the manual. Otherwise, the company shall not be liable for any personal or property damage, including damage to the product, caused by misuse or abuse.
6. For more information, please visit our official website: www.gopowerbike.com

General Warnings



Like any sport, bicycling involves risk of damage, injury, and death. By choosing to ride a bike, you assume the responsibility for that risk, so you need to know, and practice the rules of safe and responsible riding and the proper use and maintenance of this bike. Proper use and maintenance of your bike reduces risk of damage, injury, and death.



Biking and controlled substances do not mix. Never operate a bike while under the influence of alcohol, drugs, or any substance or condition that could impair motor functions, judgement, or the ability to safely operate a bike or another vehicle.



Riders must have the physical condition, reaction time, mental capability to ride safely and manage traffic, road conditions, and sudden situations, as well as respect the laws governing electric bike use where they ride, regardless of age. If you have an impairment or disability such as a visual impairment, hearing impairment, physical impairment, cognitive/language impairment, a seizure disorder, or any other physical condition that could impact your ability to safely operate a vehicle, consult your physician before riding any bike.

Limited Warranty

Warranty Info

Every bike by GoPowerbike is covered under a manufacturer's one-year all-inclusive warranty for the original owner against all manufacturing defects. GoPowerbike warrants this product, including all individual components against defects in material or workmanship as follows:

GOPOWERBIKE LIMITED 1 YEAR WARRANTY

GoPowerbike bike components including frame, forks, stem, handlebar, headset, seatpost, seat, brakes, lights, bottom bracket, crank set, pedals, rims, wheel hub, freewheel, derailleur, shifter, battery, motor, throttle, controller, wiring harness, display, kickstand, and hardware are warranted to be free from manufacturing defects in materials and/or workmanship for a 1-year period from the date of original purchase.

GoPowerbike lithium ion batteries are warranted to be free from manufacturing defects in materials and/or workmanship for a 1-year period from the date of original purchase. The battery warranty does not include damage from power surges, use of improper charger, improper maintenance or other such misuse, disassembly, normal wear, or water damage.

Warranty Exclusions

- Liability for material defects does not cover normal wear and tear, which occurs from the manufacturers' intended use of the product. Components such as the battery, motor system, braking system, drivetrain system, seat, grips, and pedals are all subject to intended use-related wear and are not covered under the warranty from normal wear.
- Damage arising from the use of the bike in a competition or other applications outside of normal intended use.
- Damage arising from improper tools, improper assembly, or improper maintenance performed on the bike.
- Damage resulting from adding non-standard equipment, parts, or modifications.

Additional Warranty Terms

This warranty does not cover any damage or defects resulting from failure to follow instructions in the owner's manual, acts of God, accidents, misuse, neglect, abuse, commercial use, alterations, modification, improper assembly, wear and tear, installation of parts or accessories not originally intended or compatible with the bike as sold, operator error, water damage, extreme riding, stunt riding, or improper follow-up maintenance. This warranty does not include normal wear and tear or consumable parts designed to wear down over time, including tires, tubes, brake pads, cables and housing, spokes, and handlebar grips.

GoPowerbike will not be liable and/or responsible for any damage, failure, or loss caused by any unauthorized service or use of unauthorized parts. In no event shall GoPowerbike be responsible for any direct, indirect, or consequential damages, including without limitation, damages for personal injury, property damage, or economic losses, whether based on contract, warranty, negligence, or product liability in connection with their products. All claims to this warranty must be made through GoPowerbike. Proof of purchase is required with any warranty request.

Determining whether damage or defect to an ebike, or covered component, is protected by this limited warranty and shall be in the sole discretion of GOPOWERBIKE.

We are here to help!

If you have questions:
Contact us directly by email to
help@gopowerbike.com