

MERAN COFFEE TABLE

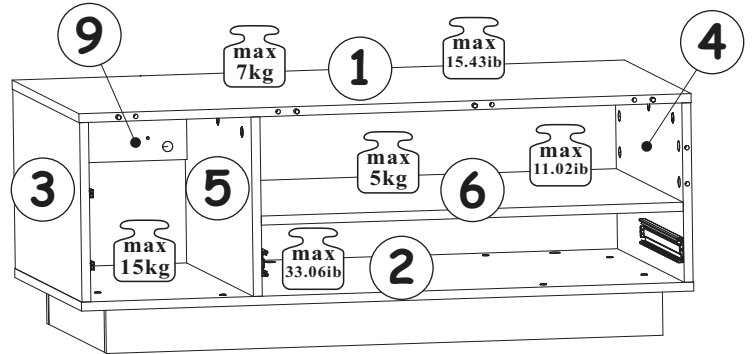

SCAN THIS QR CODE FOR INSTRUCTION MANUALS AND ASSEMBLY VIDEOS

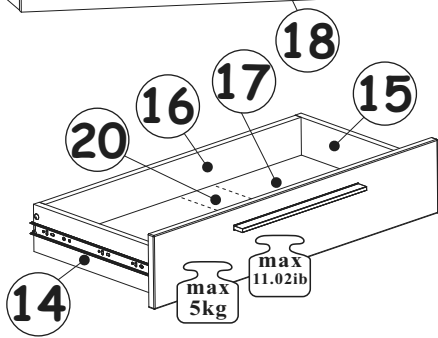
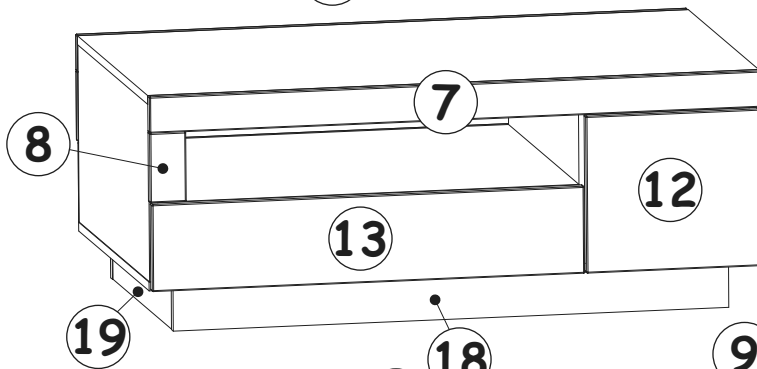
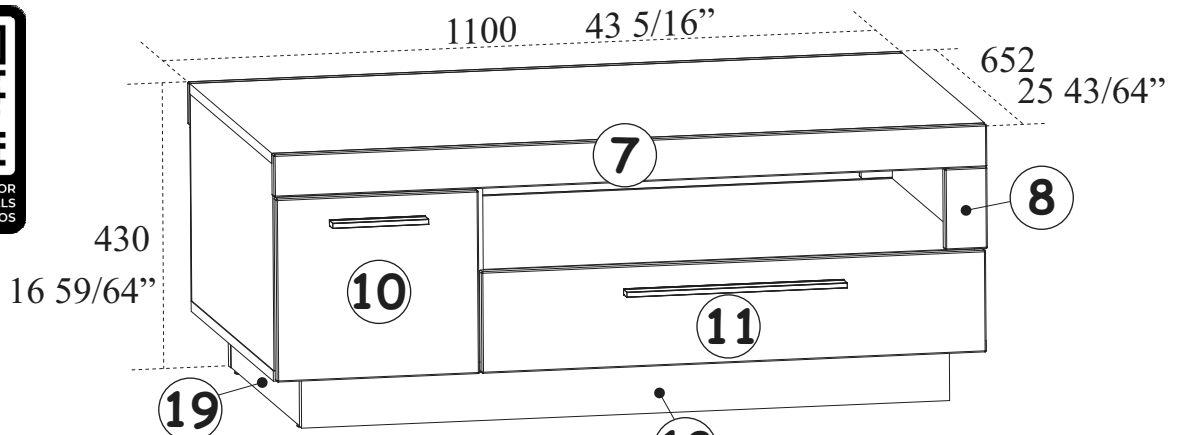

NO	Dim			Col.-No	Qty
1	1100	620	16	2	1
2	1100	620	16	2	1
3	319	620	16	1	1
4	319	620	16	1	1
5	319	620	16	1	1
6	758	620	16	2	1
7	1100	65	16	2	2
8	126	65	16	1	2
9	292	80	16	1	1
10	313	282	16	1	1
11	780	156	16	2	1
12	313	282	16	1	1
13	780	156	16	2	1
14	350	100	16	1	1
15	350	100	16	1	1
16	701	80	16	1	1
17	713	353	3	1	1
18	1000	80	16	2	2
19	520	80	16	1	2
20	349	80	16	1	1

NO	Inch			Col.-No	Qty
1	43 5/16	24 13/32	5/8	2	1
2	43 5/16	24 13/32	5/8	2	1
3	12 9/16	24 13/32	5/8	1	1
4	12 9/16	24 13/32	5/8	1	1
5	12 9/16	24 13/32	5/8	1	1
6	29 27/32	24 13/32	5/8	2	1
7	43 5/16	2 9/16	5/8	2	2
8	4 61/64	2 9/16	5/8	1	2
9	11 1/2	3 5/32	5/8	1	1
10	12 21/64	11 7/64	5/8	1	1
11	30 45/64	6 9/64	5/8	2	1
12	12 21/64	11 7/64	5/8	2	1
13	30 45/64	6 9/64	5/8	2	1
14	13 25/32	3 15/16	5/8	1	1
15	13 25/32	3 15/16	5/8	1	1
16	27 19/32	3 5/32	5/8	1	1
17	28 5/64	13 57/64	1/8	1	1
18	39 3/8	3 5/32	5/8	2	2
19	20 15/32	3 5/32	5/8	1	2
20	13 47/64	3 5/32	5/8	1	1

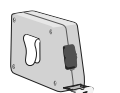
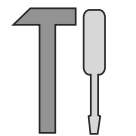
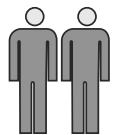





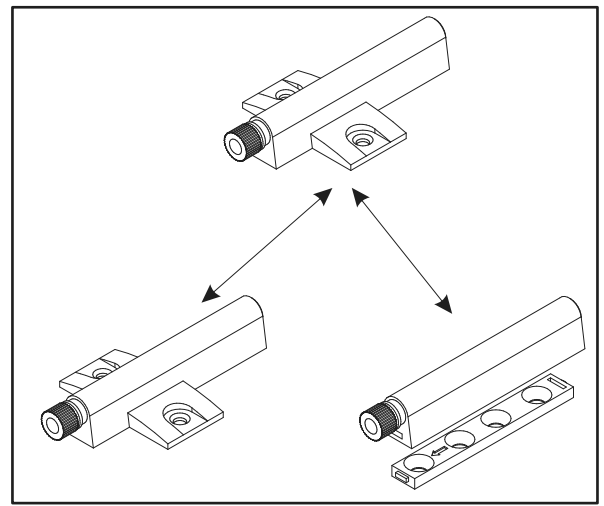
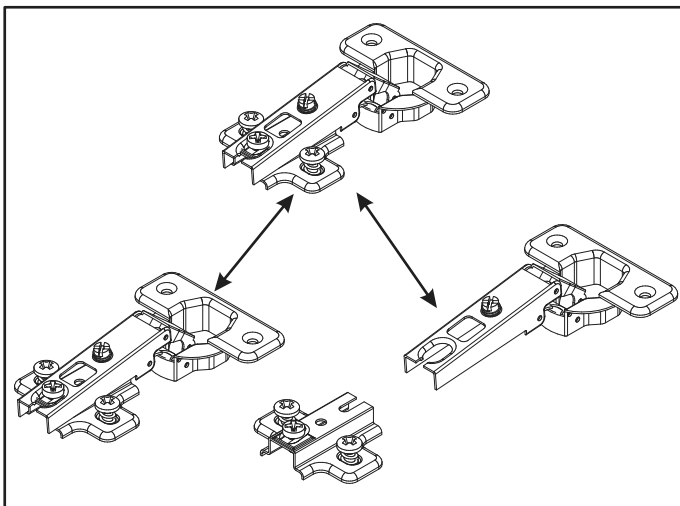
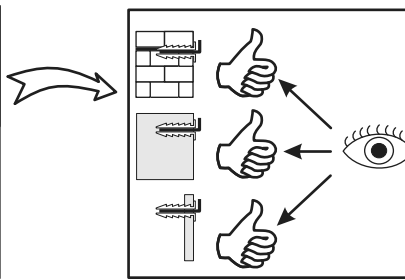
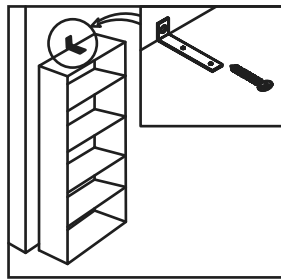
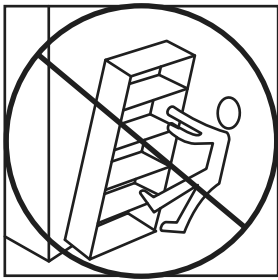
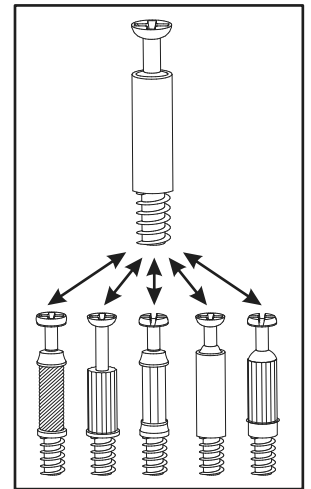
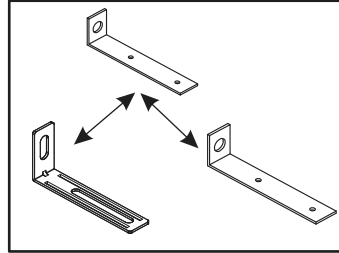
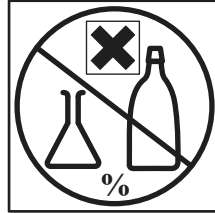
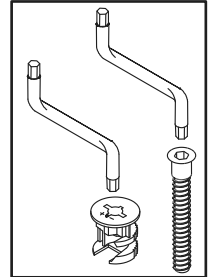
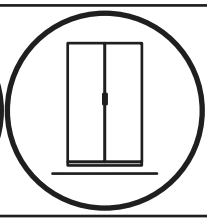
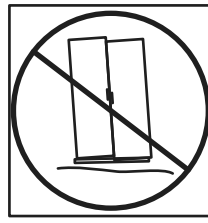
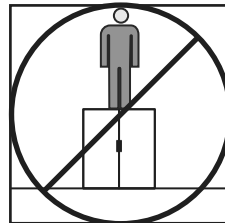
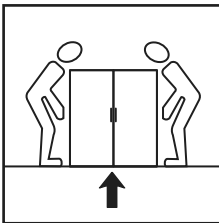
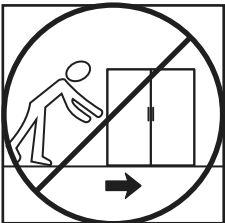
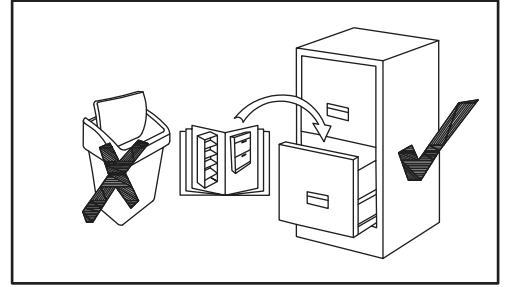
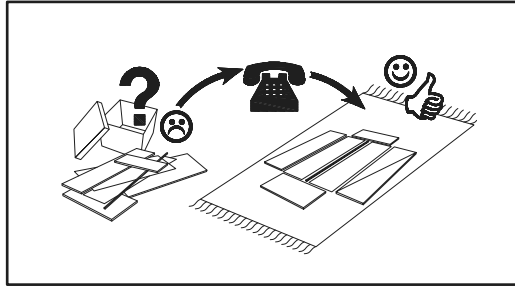
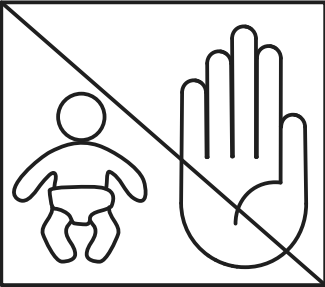
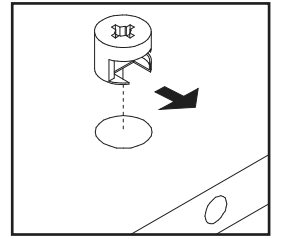
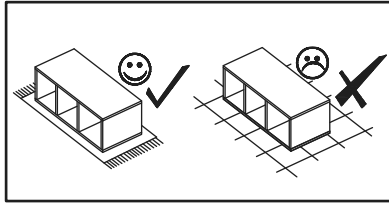
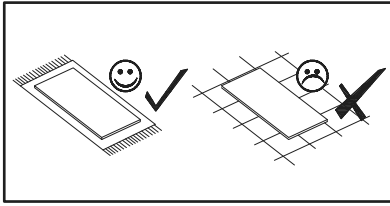



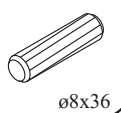
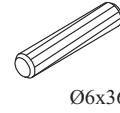

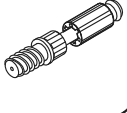

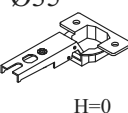
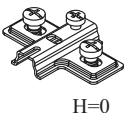
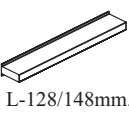
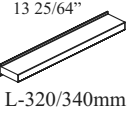
90 min

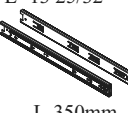
MERAN CT

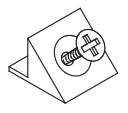

MERAN CT

A1 x38  Ø5/16"x1 27/64" Ø8x36	A4 x6  Ø15/64"x1 27/64" Ø6x36	B11 x21  Ø9/32"x1 31/32" Ø7x50	G4 x19 	B4 x41 	B5 x41  Ø19/32"x15/32" Ø15x12
G5 x41 	E21 x2  Ø35 H=0	E2 x2  H=0	BG1 x1  L-5 3/64"/5 53/64" L-128/148mm.	BG2 x1  L-12 19/32"/ 13 25/64" L-320/340mm.	UP6 x9  UPØ4x30
I2 x4 	H8 x1  L- 13 25/32" L-350mm.	D10 x8  USØ9/64"x33/64" USØ3,5x13	UP13 x4  USØ1/8"x5/8" UPØ3x16	D14 x4  ESØ6,3x13	S1 x2 
G2 x1 					

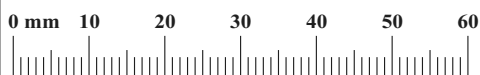

MERAN CT

1

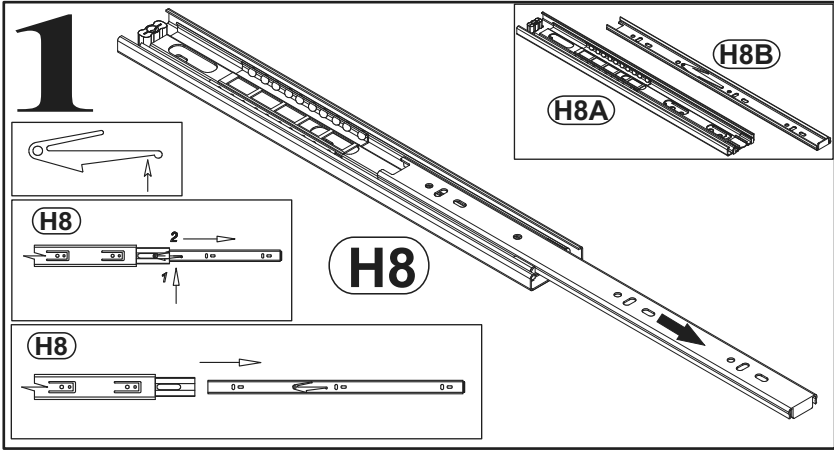
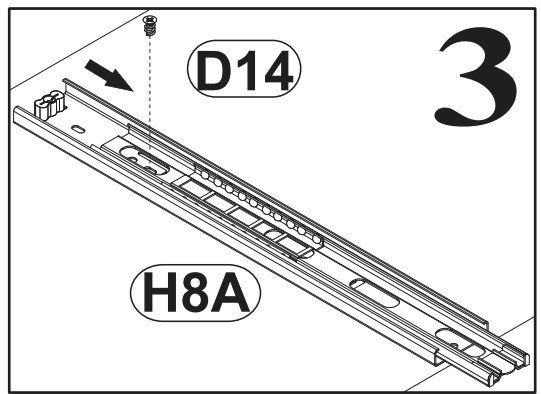
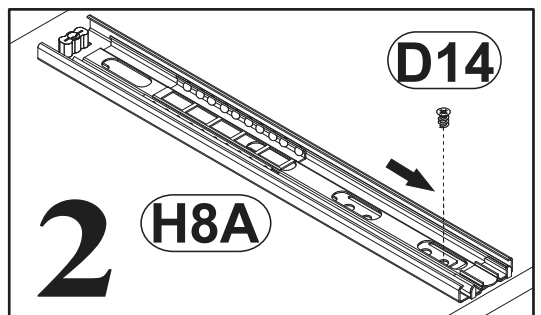
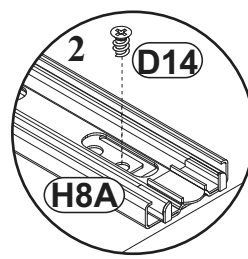
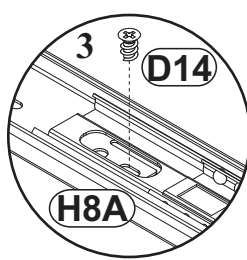
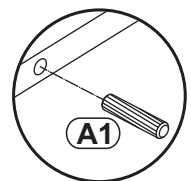
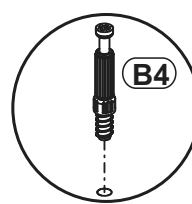
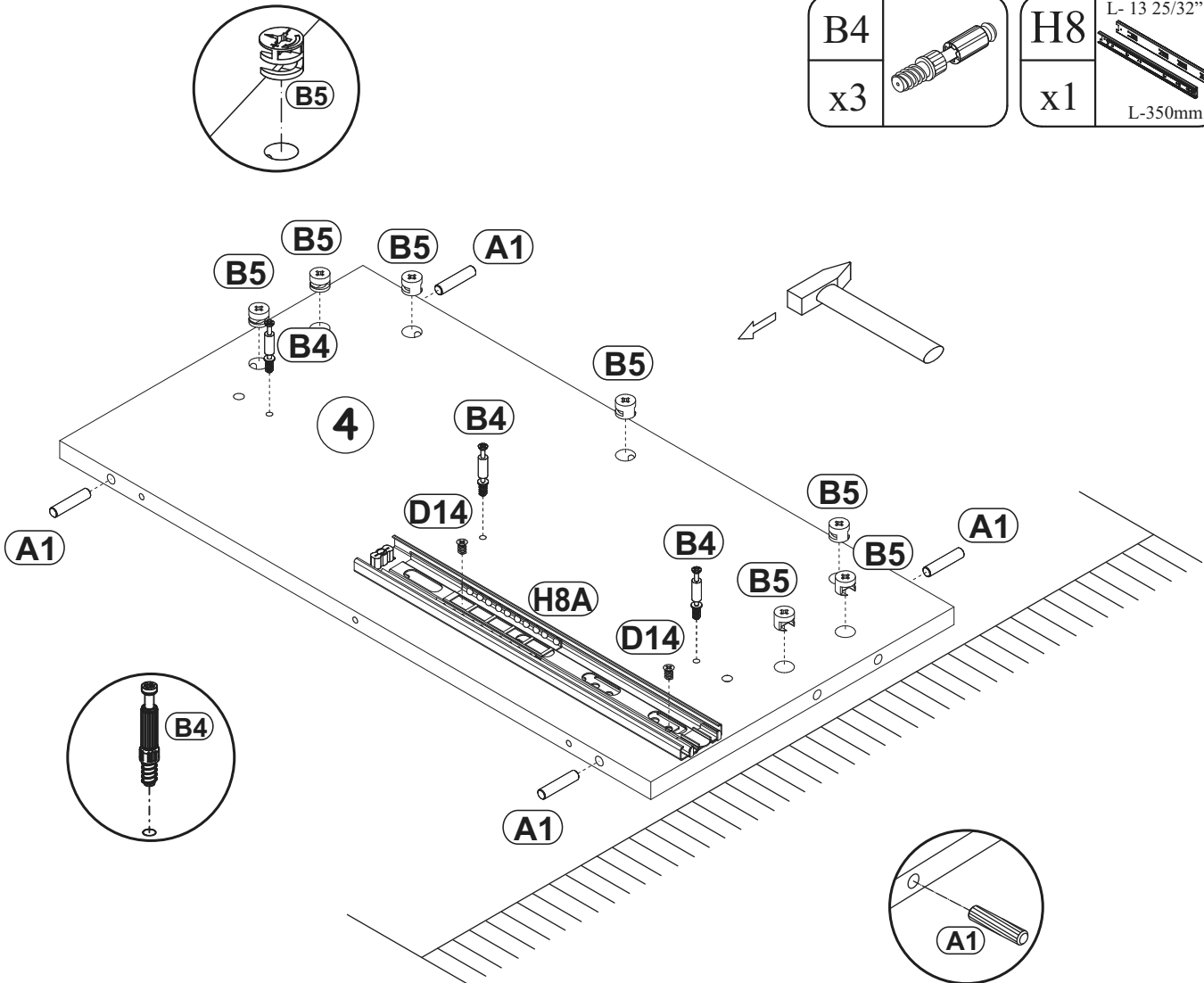
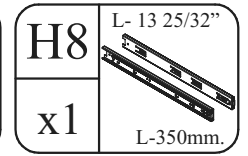
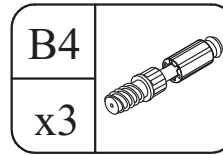
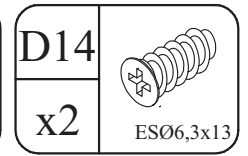
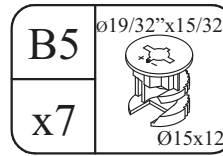
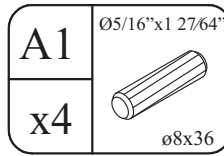

MERAN CT

2

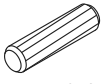
A1	Ø5/16"x1 27/64"
x4	 ø8x36

B5	Ø19/32"x15/32"
x3	 Ø15x12

H8	L- 13 25/32"
x1	 L-350mm.

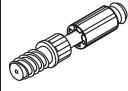
B4	
x4	

D14	
x2	ESØ6,3x13

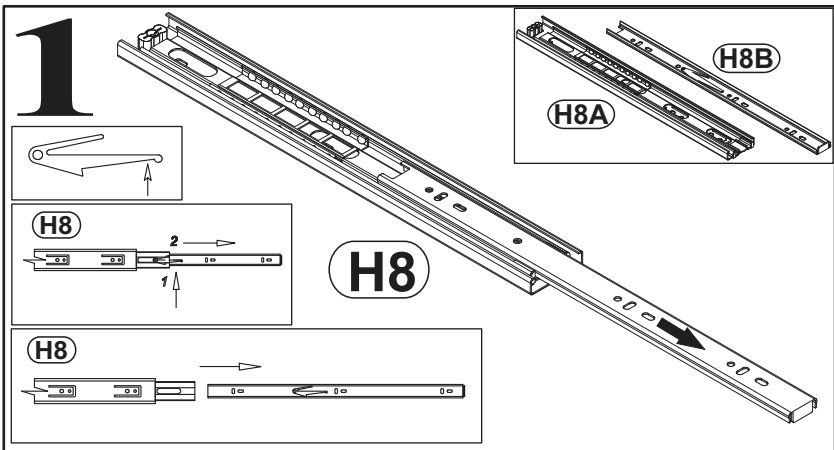
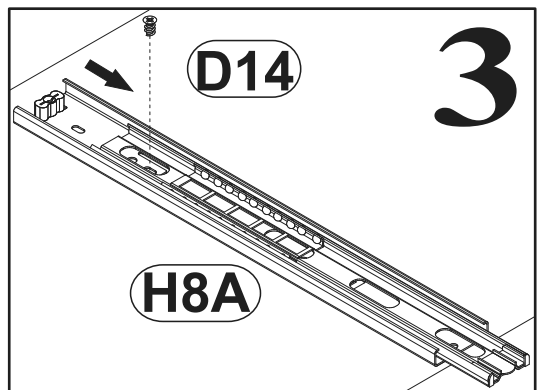
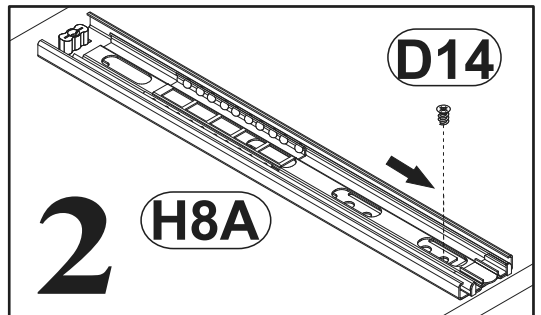
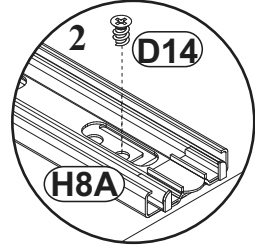
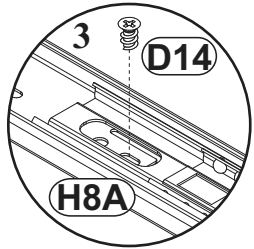
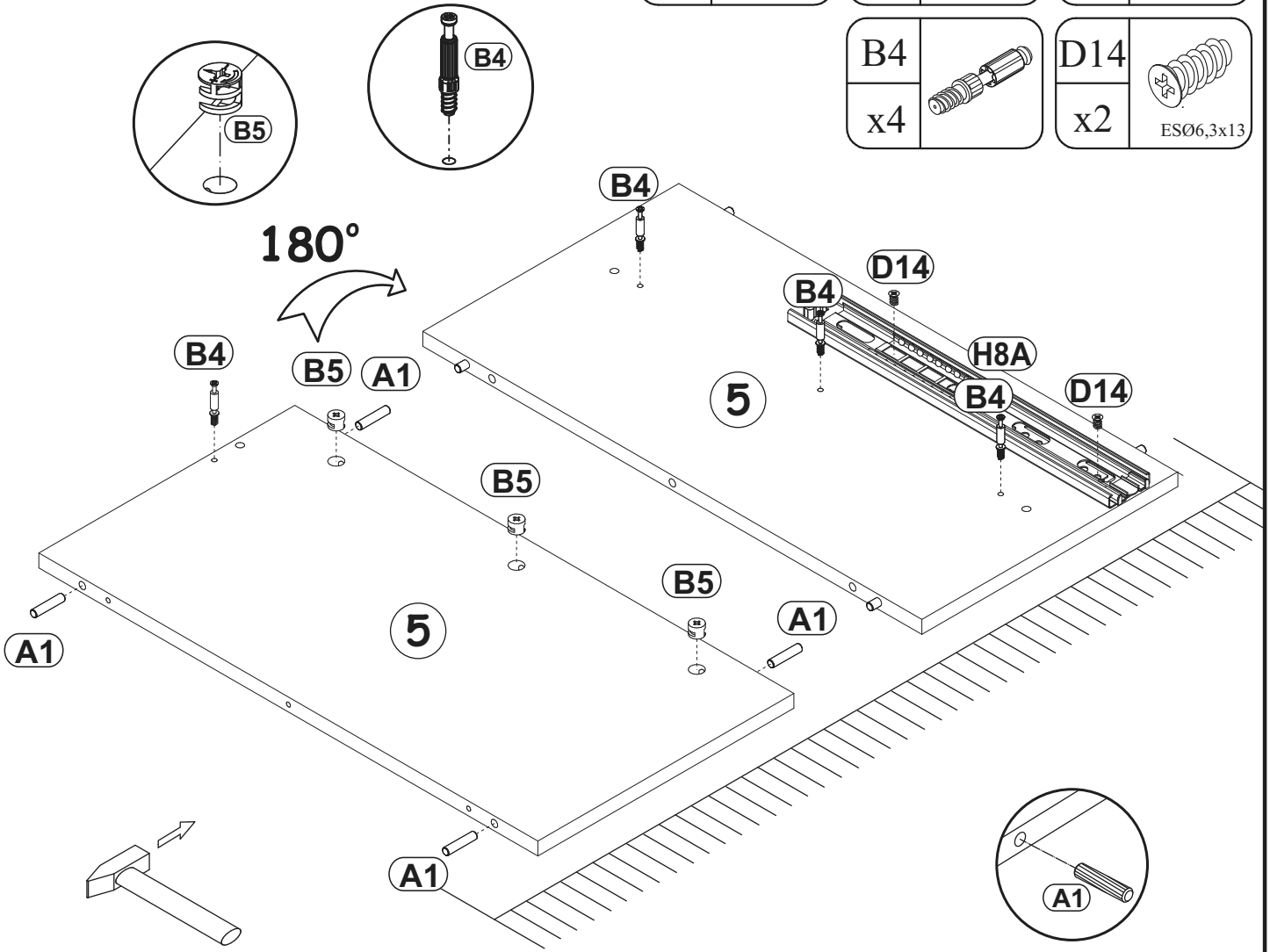



MERAN CT

3

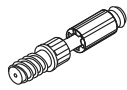
A1	Ø5/16"x1 27/64"
x4	 ø8x36

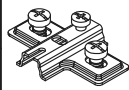
B4	
x1	

E2	
x2	H=0

B5	Ø19/32"x15/32"
x3	 Ø15x12

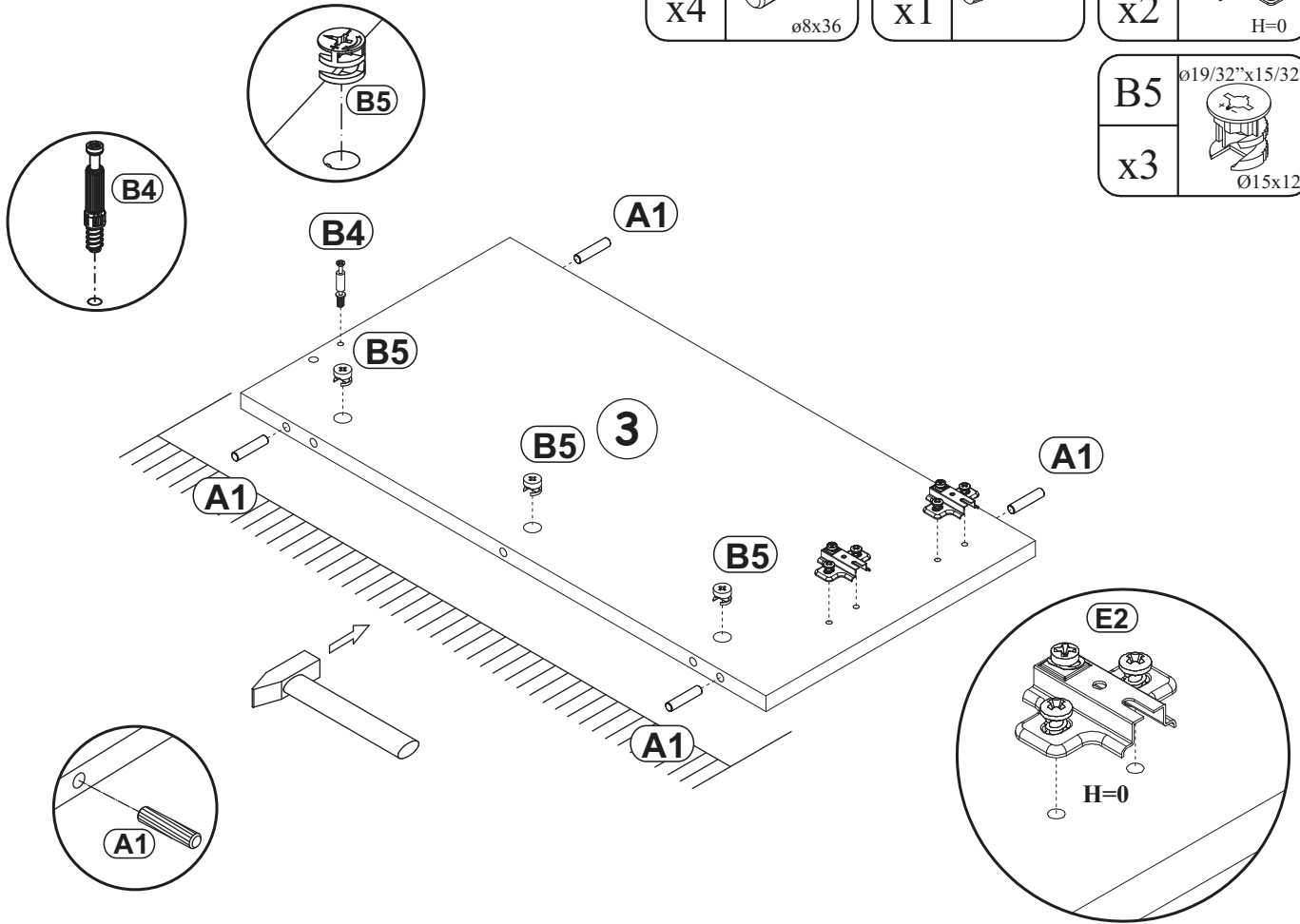

4

A1	Ø5/16"x1 27/64"
x8	 ø8x36

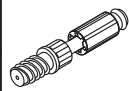
B4	
x9	

B5	Ø19/32"x15/32"
x8	 Ø15x12

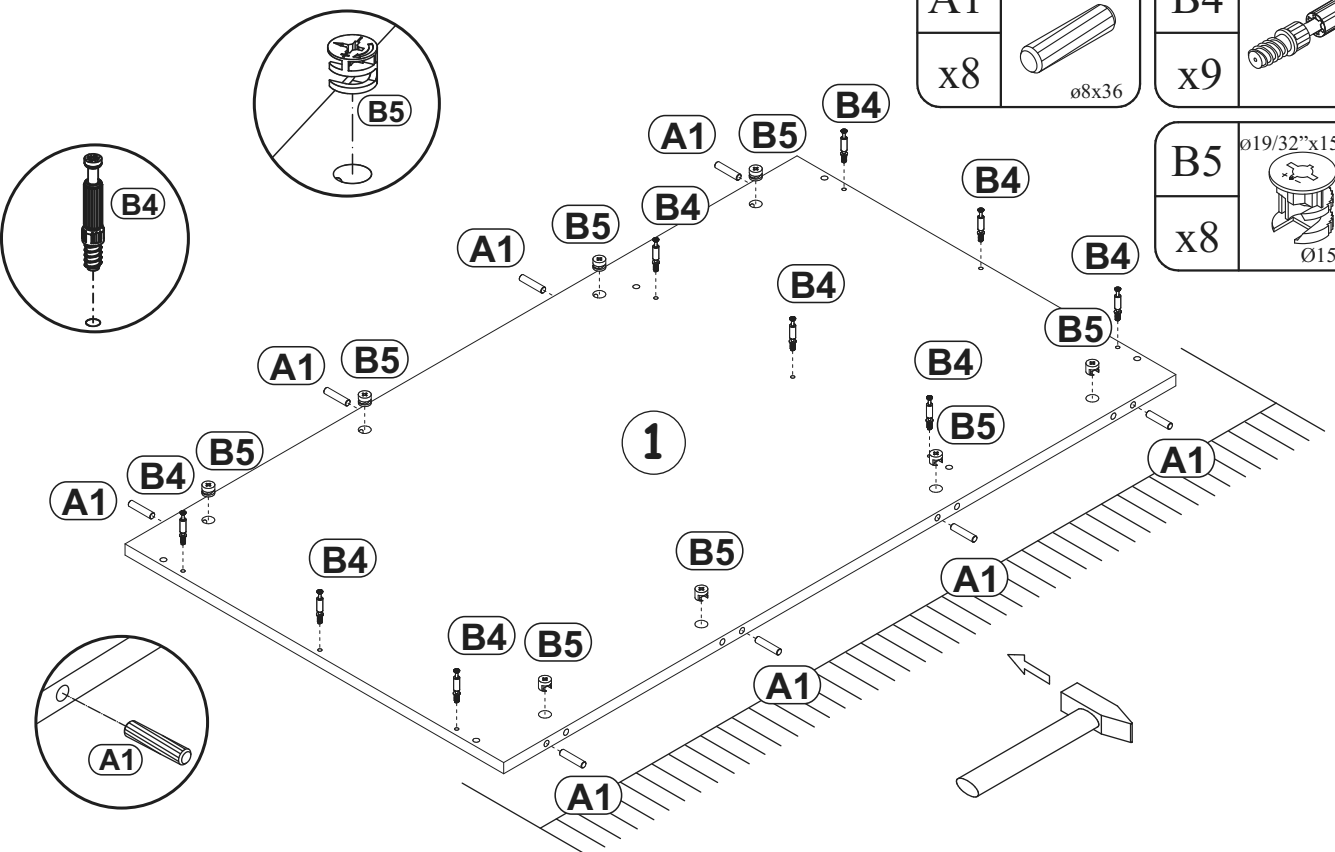

5

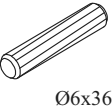
B5	Ø19/32"x15/32"	A4	Ø15/64"x1 27/64"
x4	 Ø15x12	x4	 Ø6x36

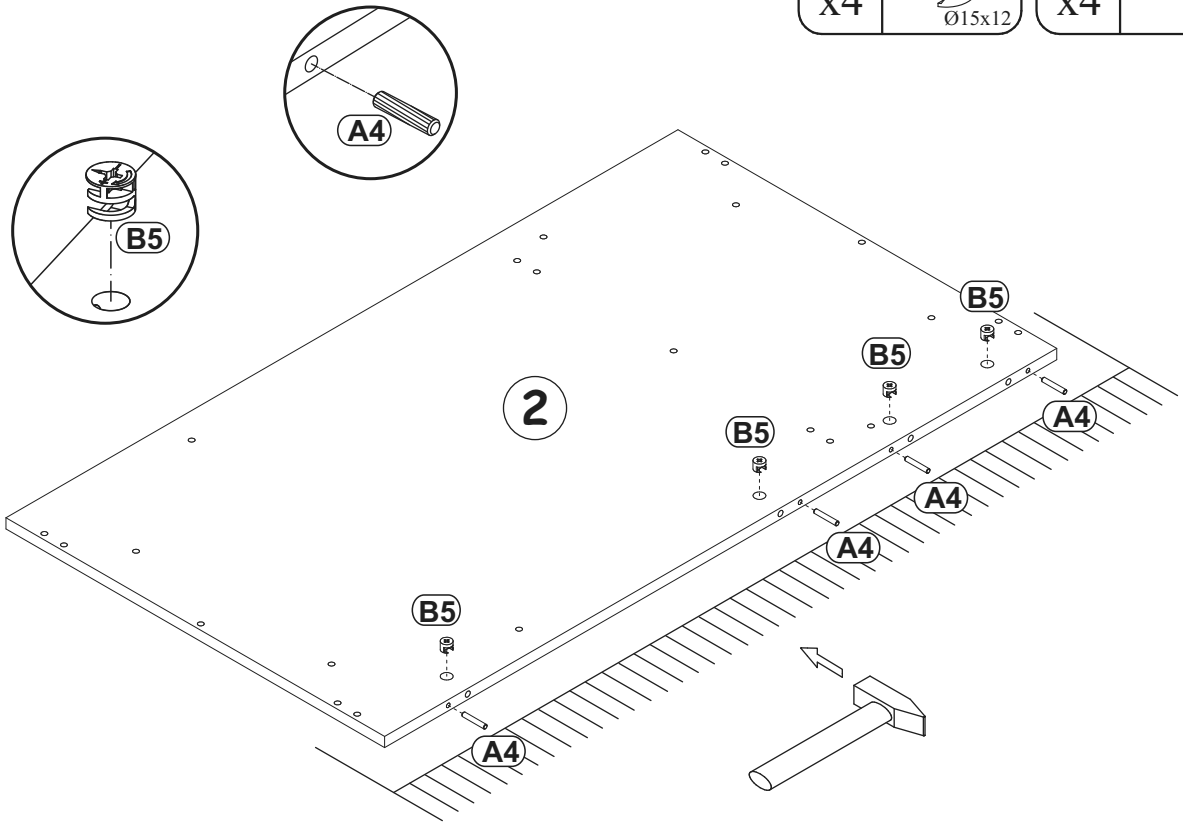

6

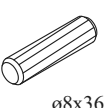
B5	Ø19/32"x15/32"	A1	Ø5/16"x1 27/64"
x8	 Ø15x12	x4	 Ø8x36

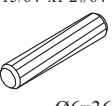
A4	Ø15/64"x1 27/64"
x2	 Ø6x36

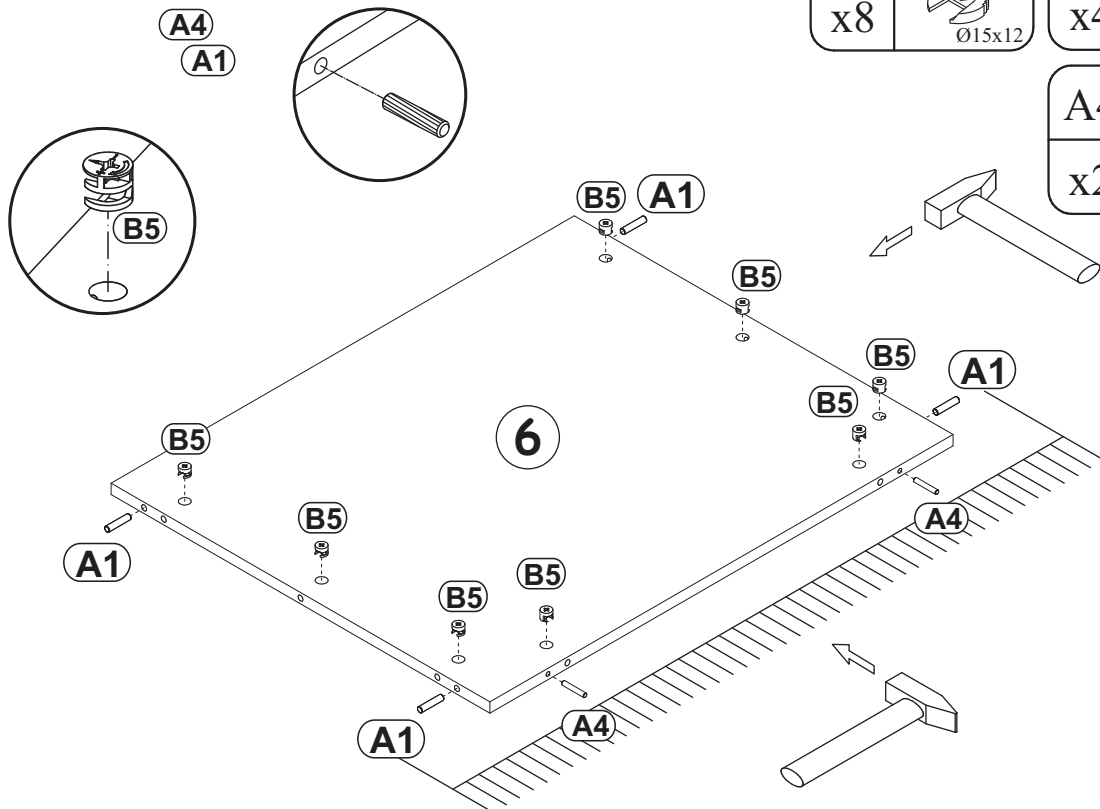

MERAN CT

7

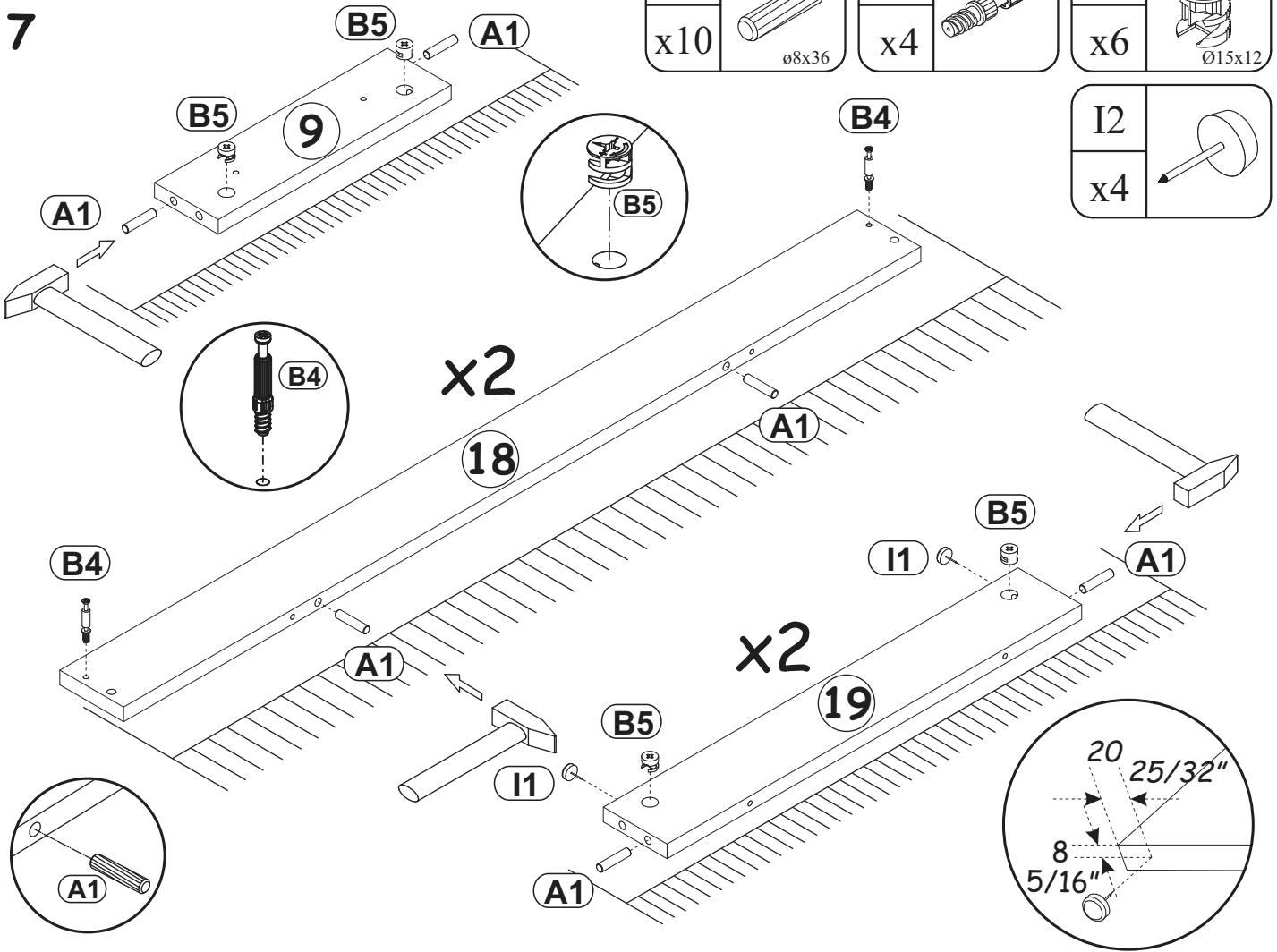

A1	Ø5/16"x1 27/64"
x10	ø8x36

B4	
x4	

B5	Ø19/32"x15/32"
x6	

I2	
x4	

8

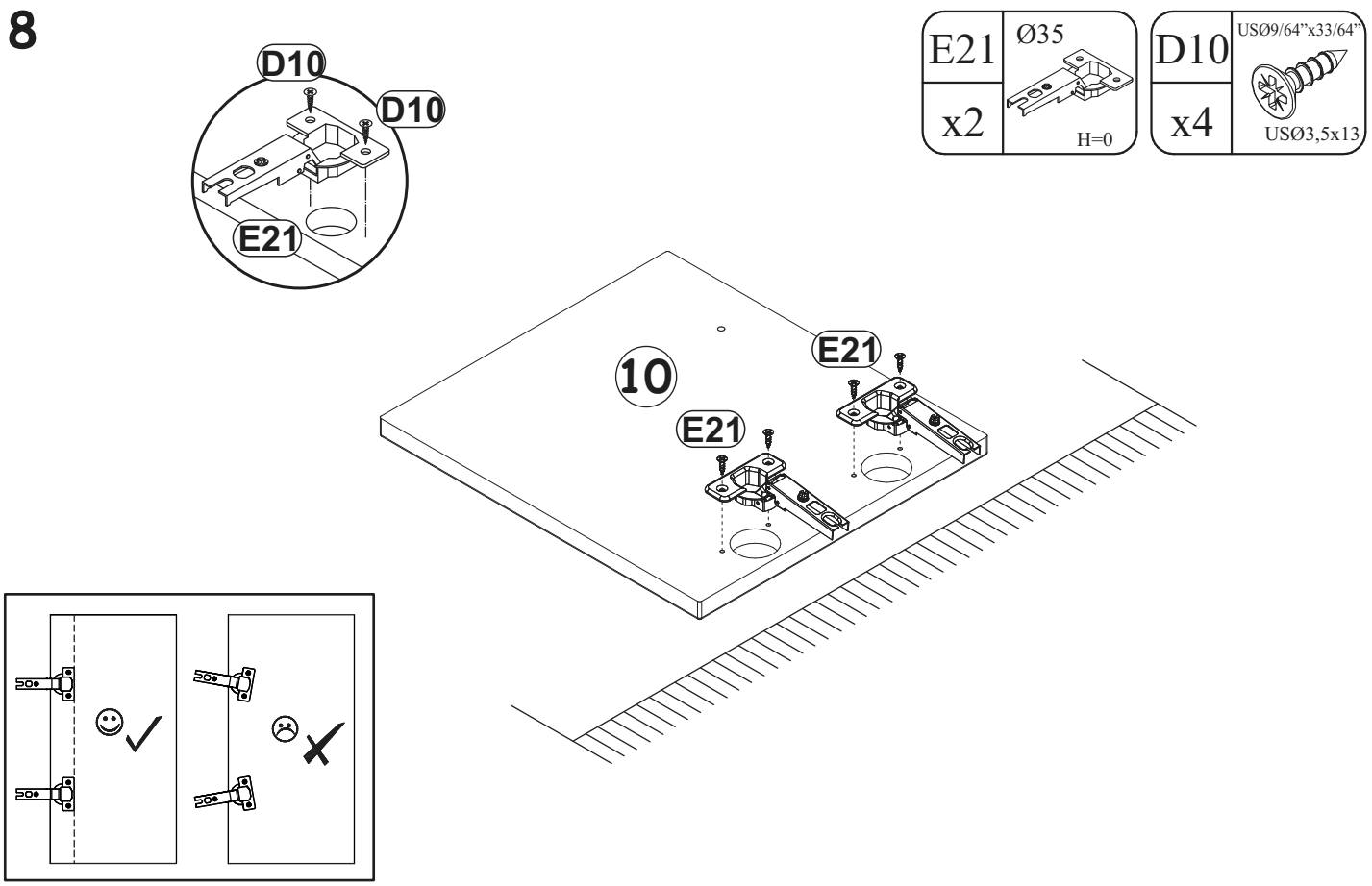

E21	Ø35
x2	H=0

D10	USØ9/64"x33/64"
x4	USØ3,5x13

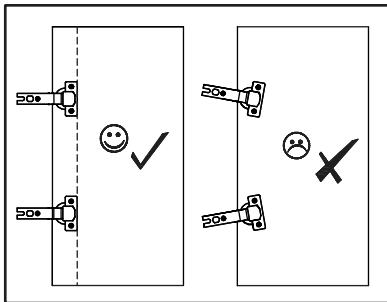



9

B4

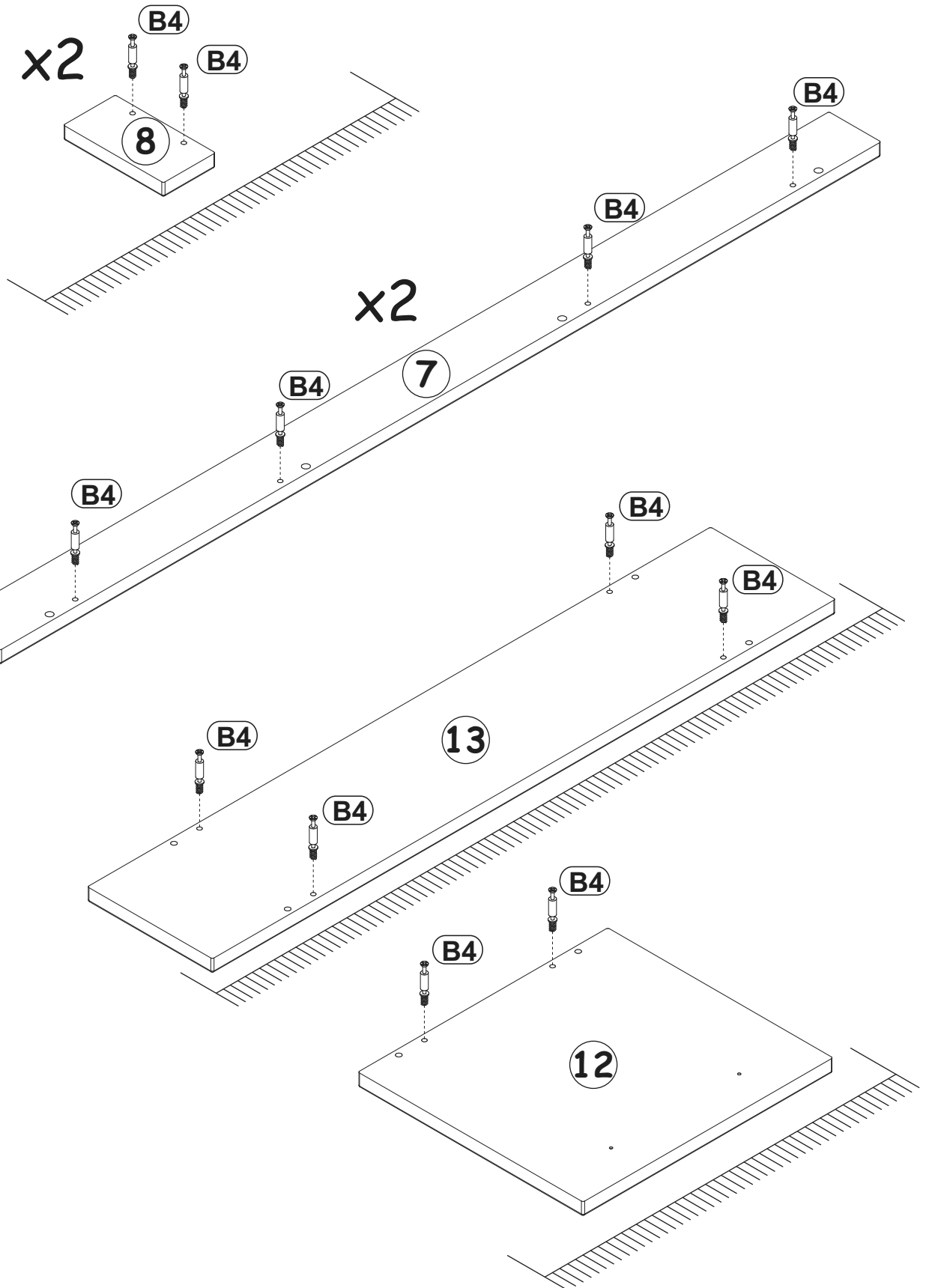
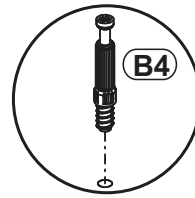
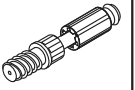
x18

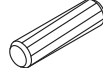

A1	Ø5/16"x1 27/64"
x4	 ø8x36

B5	Ø19/32"x15/32"
x2	 Ø15x12

10

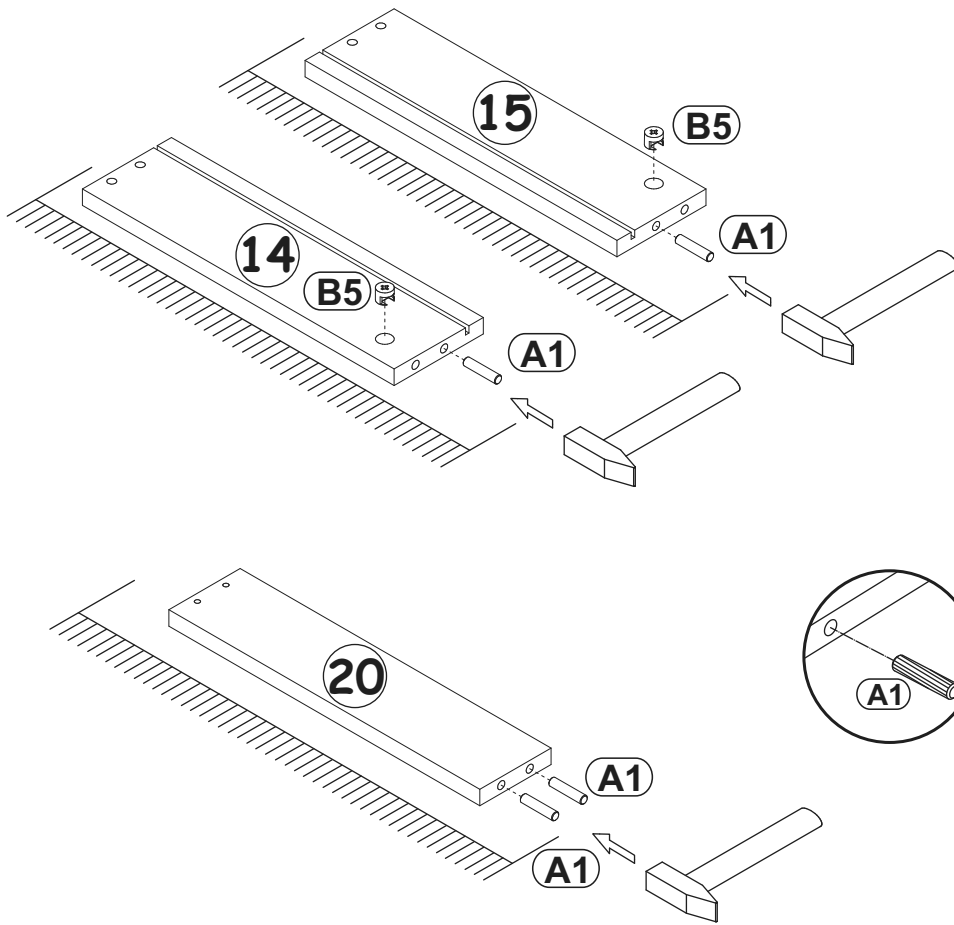

11

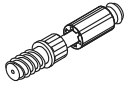
B4	
x2	

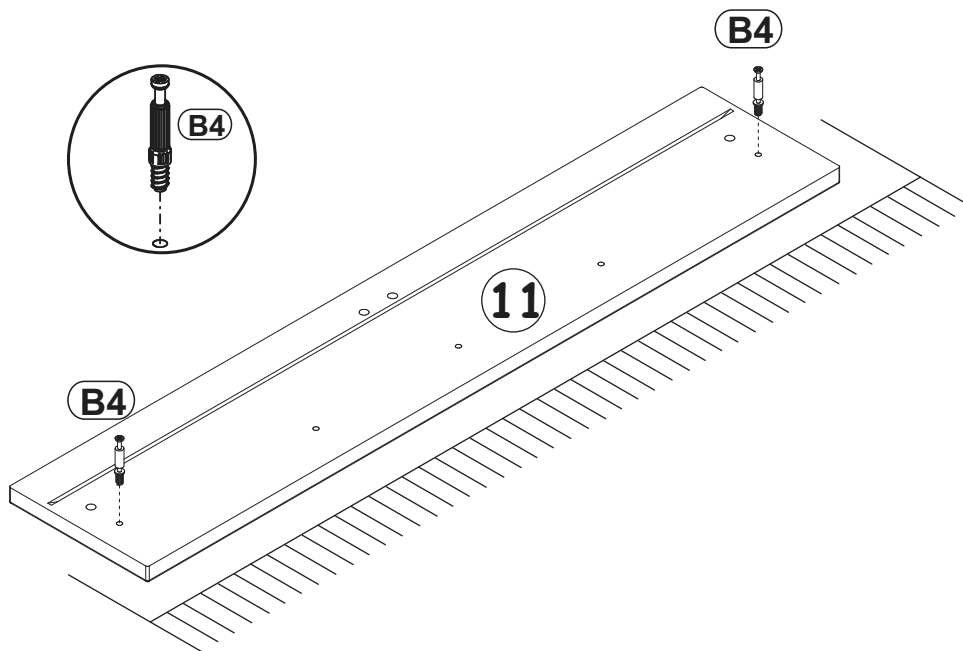



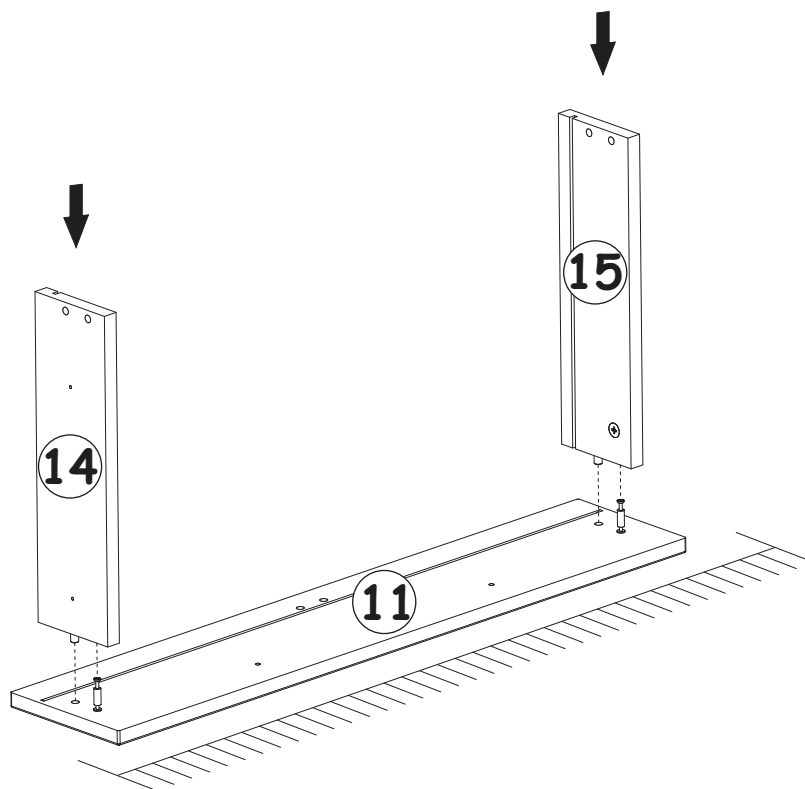

12

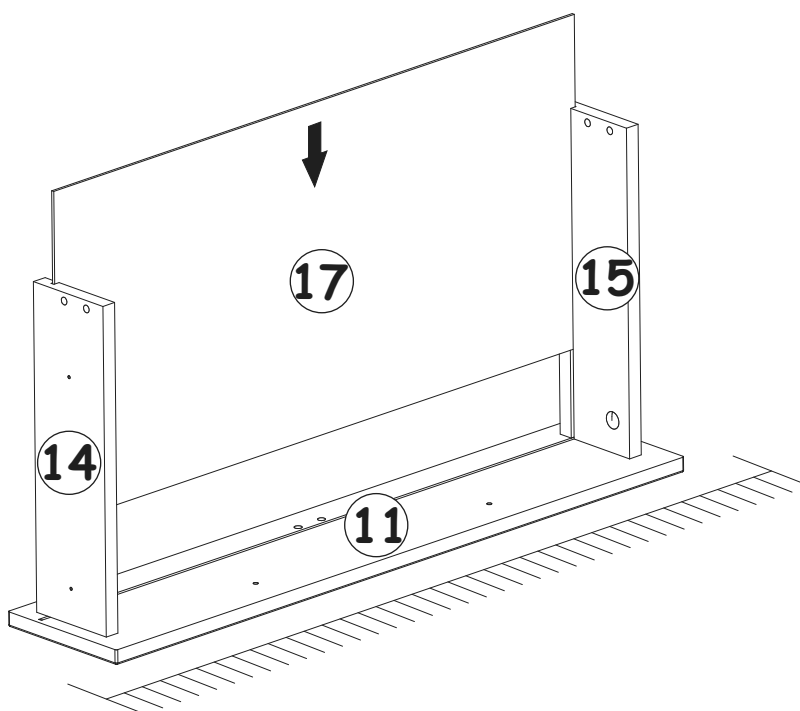

13



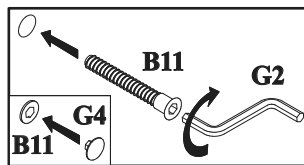
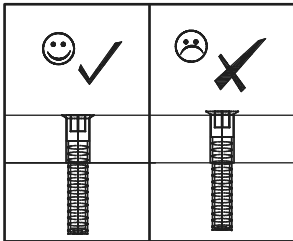
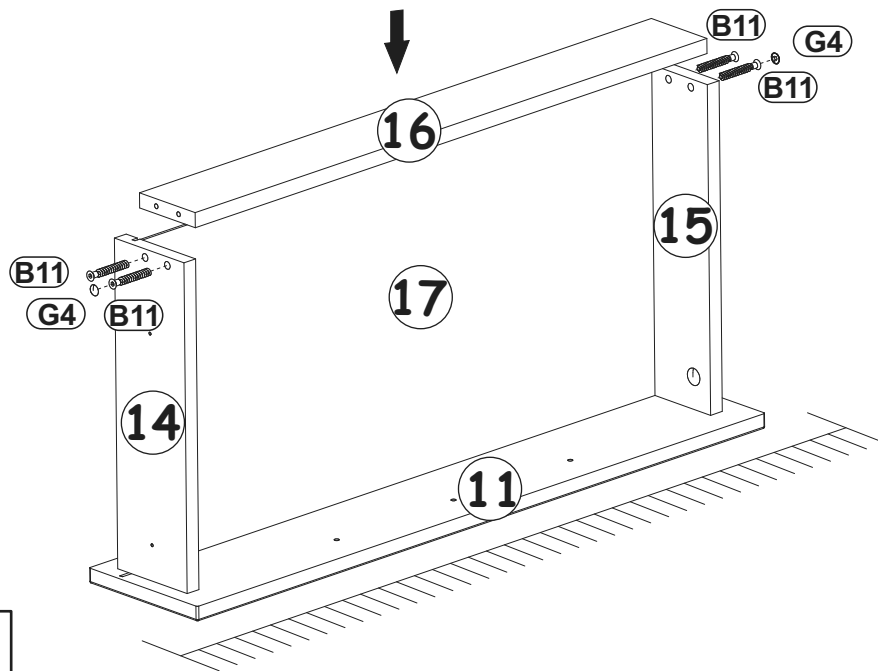

14

G4		B11	
x2		x4	Ø9/32"x1 31/32" Ø7x50



15

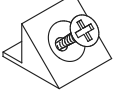

S1		UP13	
x2		x4	USØ1/8"x5/8" UPØ3x16

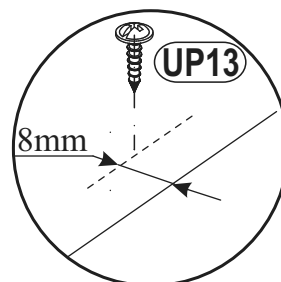
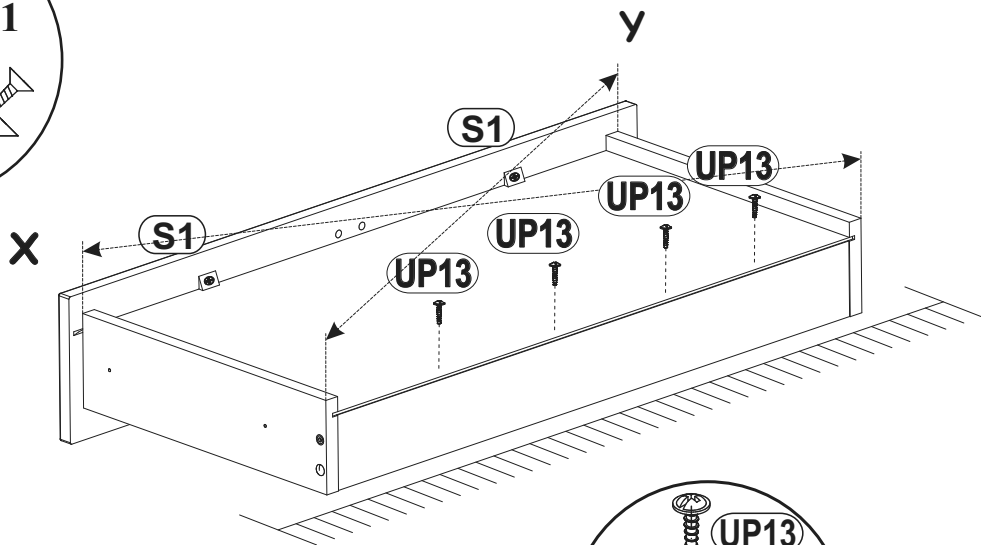
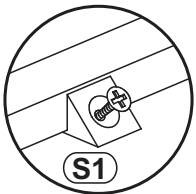
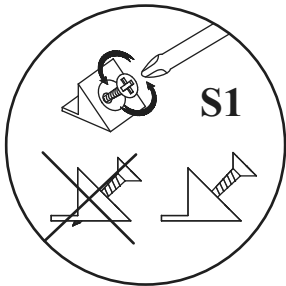

16

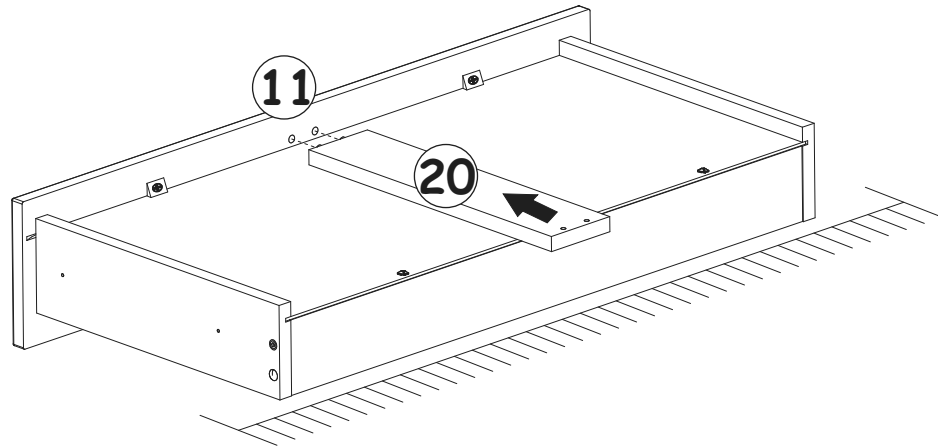

17

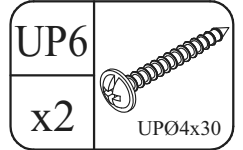
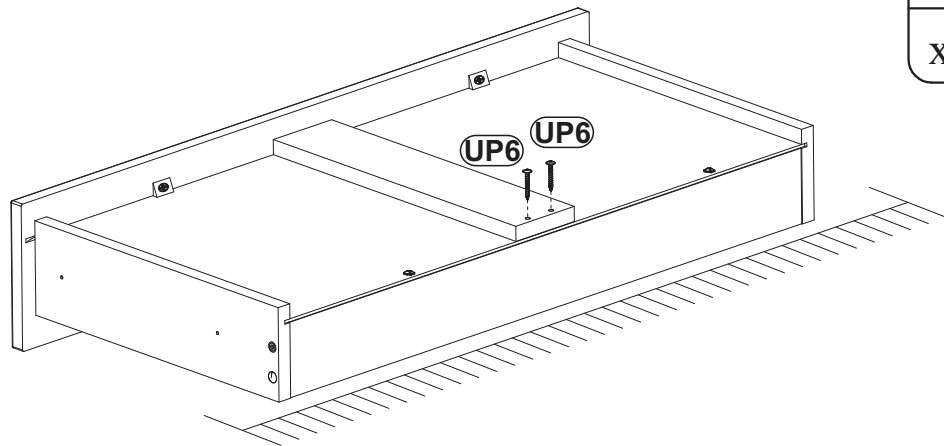

18

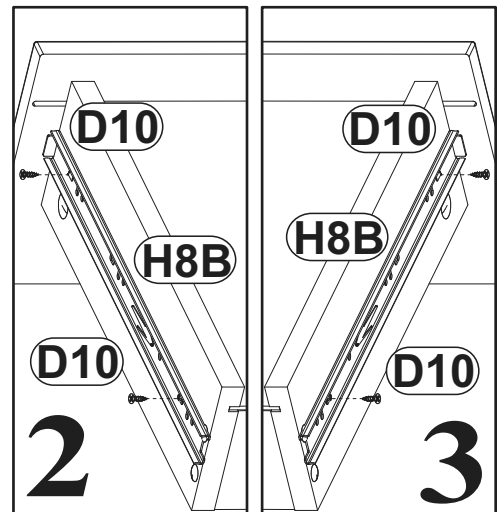
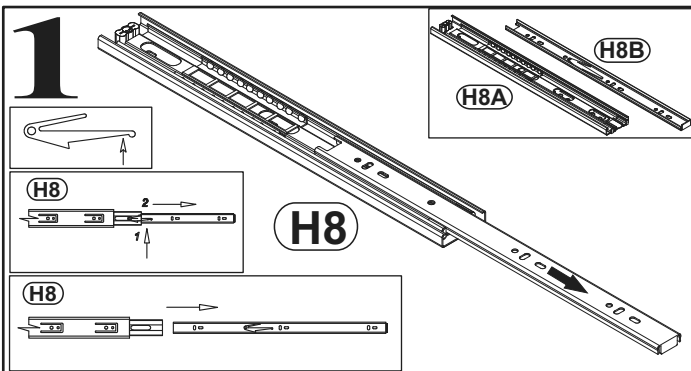
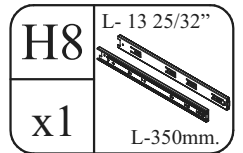
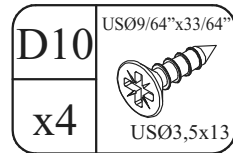
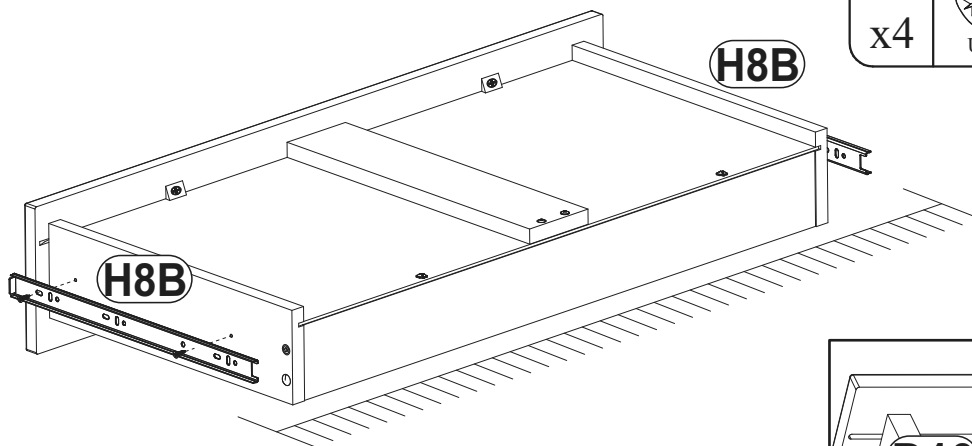

MERAN CT

19

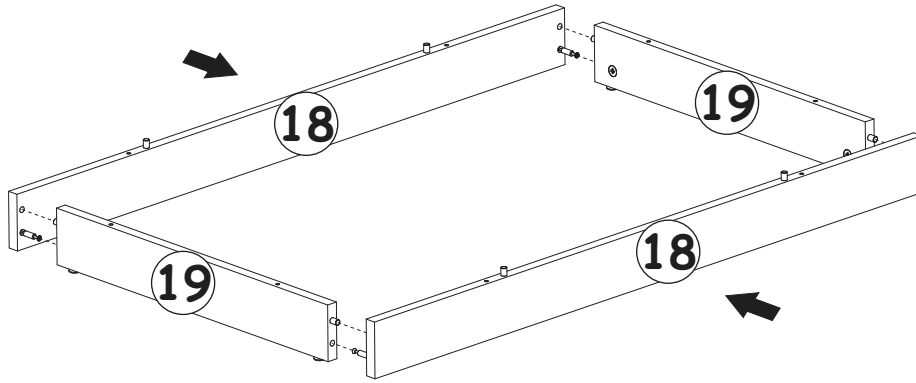

G5	
x4	

20

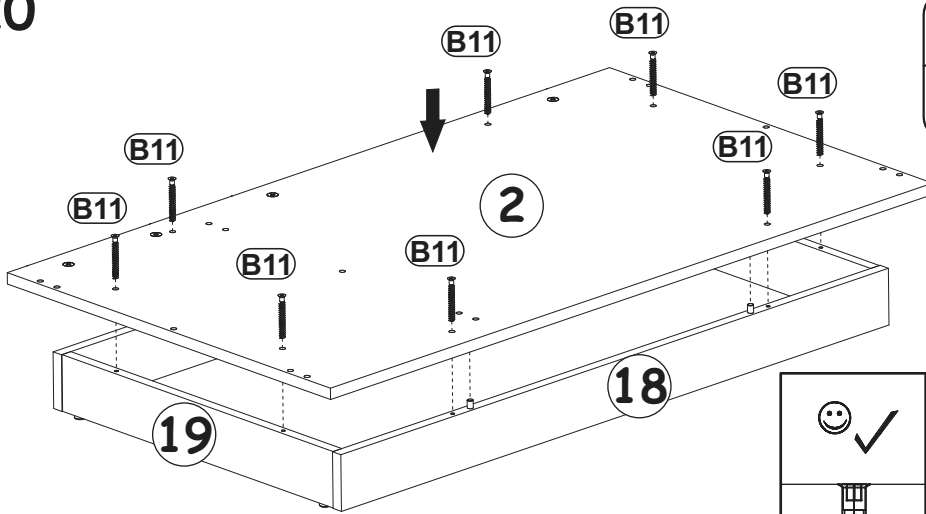

B11	Ø9/32"x1 31/32"
x8	Ø7x50

G4	
x8	

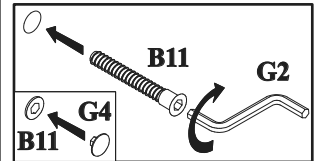
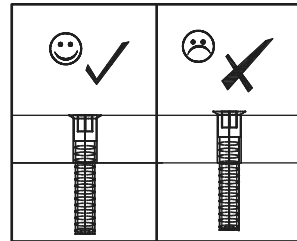

21

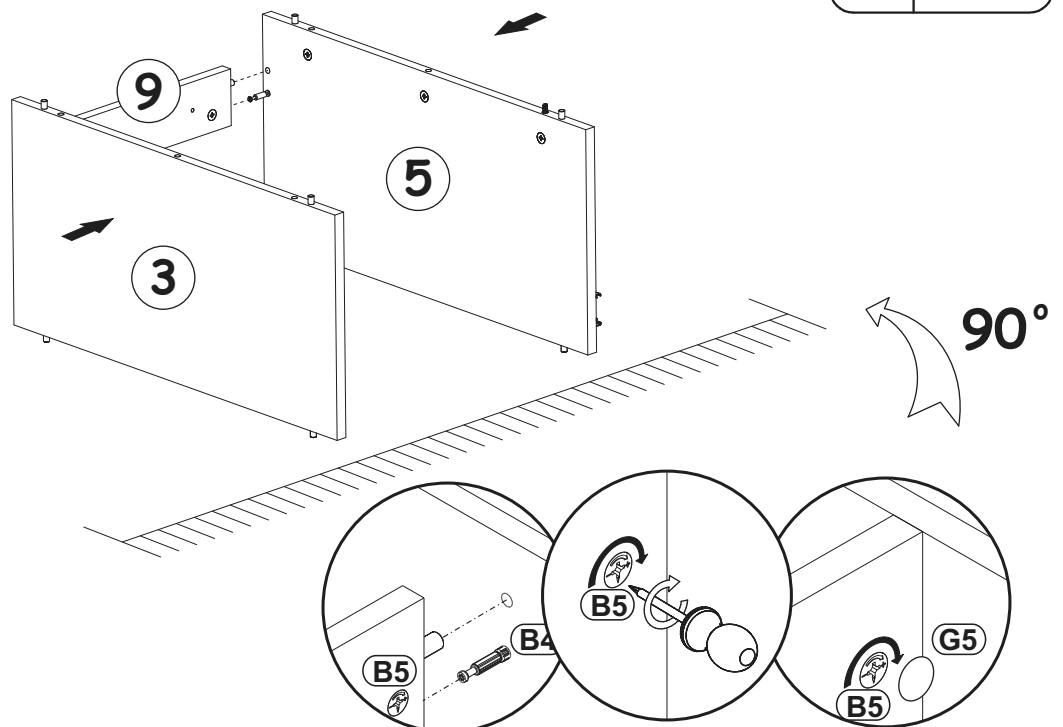

G5	
x2	

22

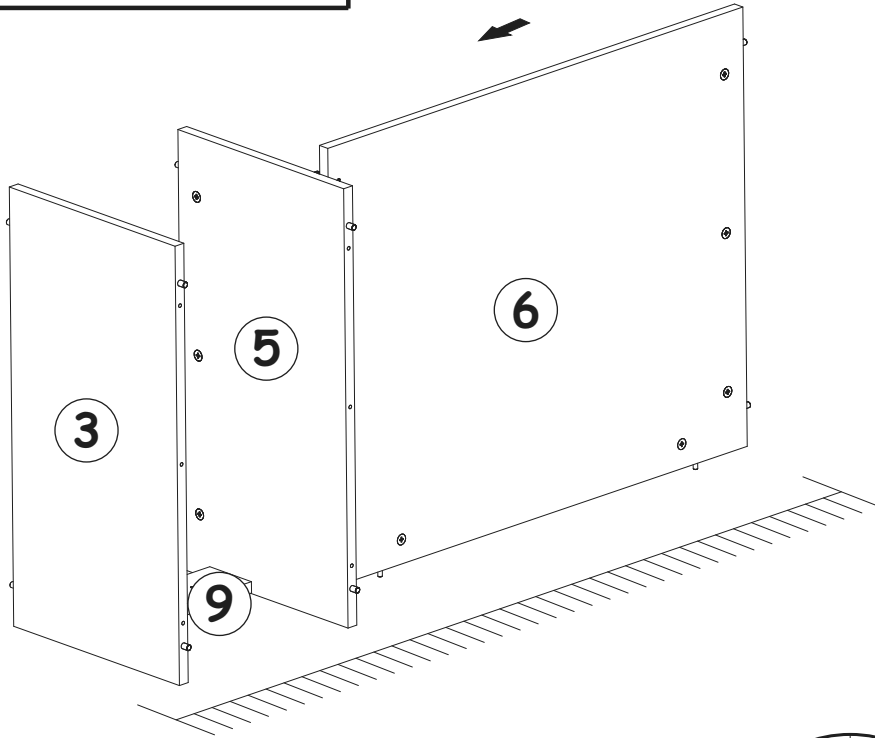

G5	
x3	

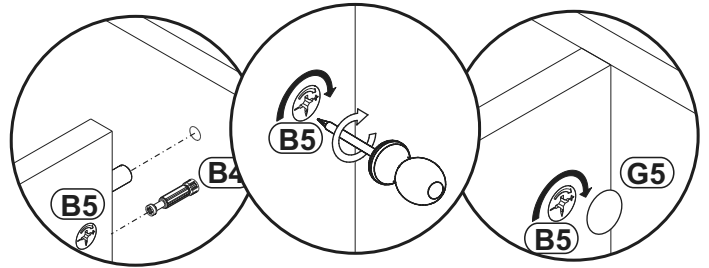

23

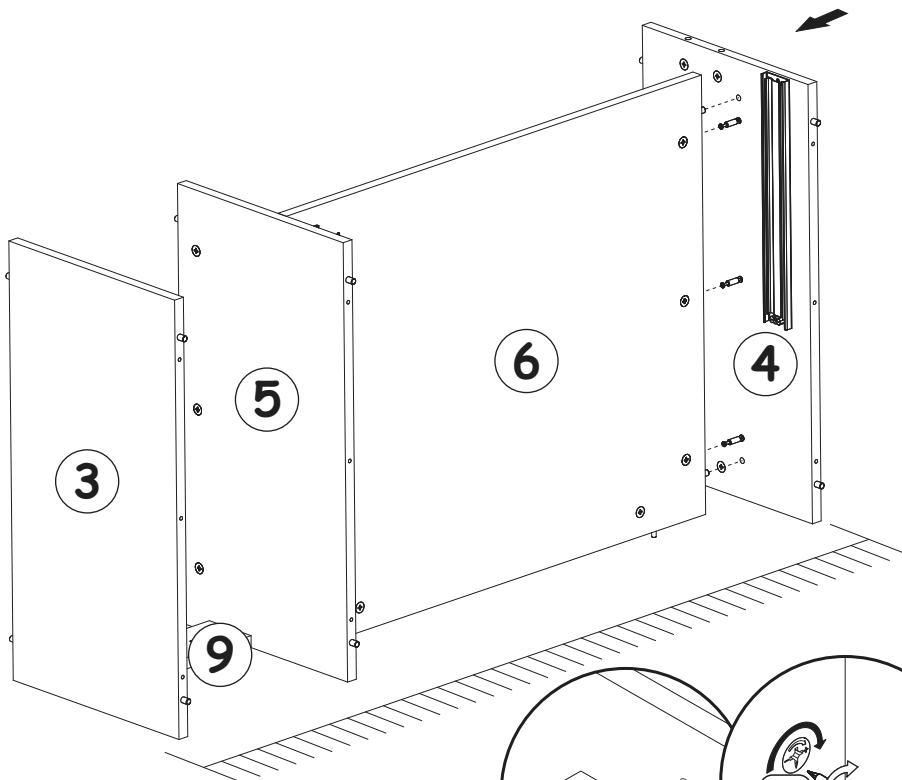

G5	
x3	

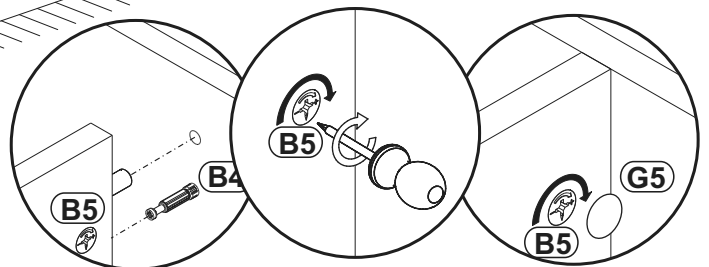

24

B11	Ø9/32"x1 31/32"	G4	
x9	Ø7x50	x9	

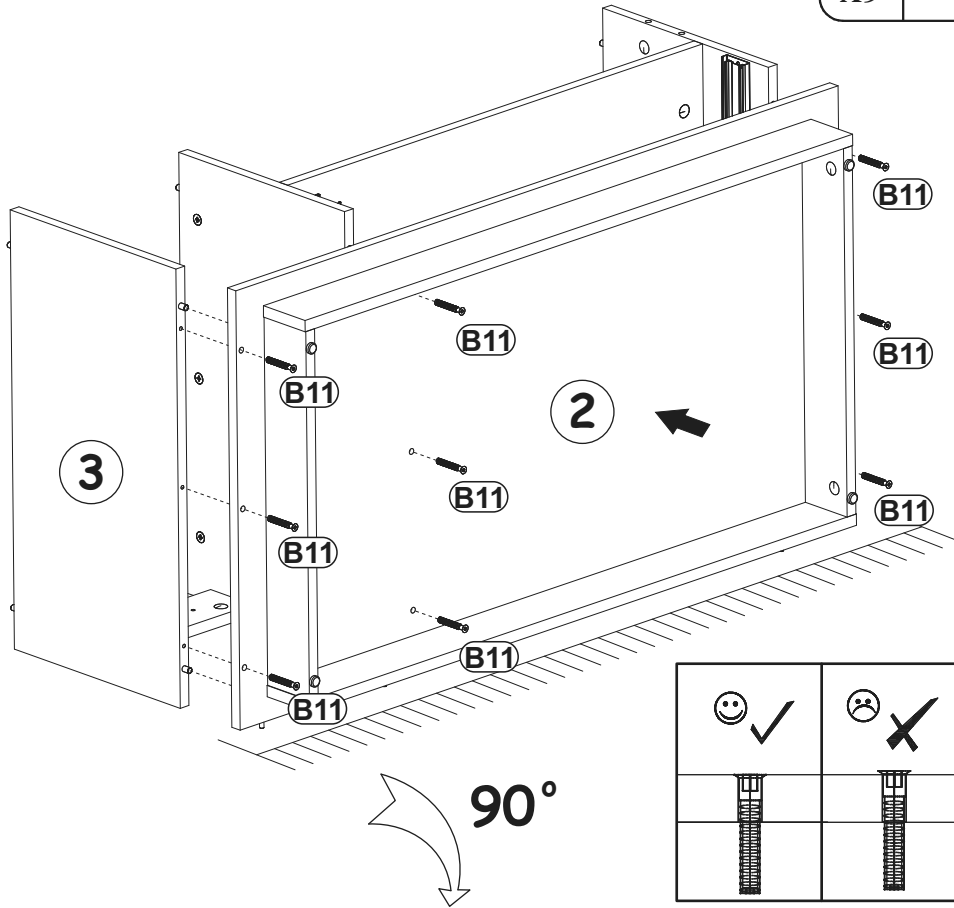

25

G5	
x9	

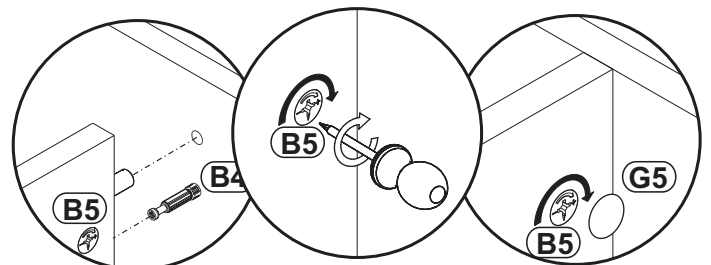
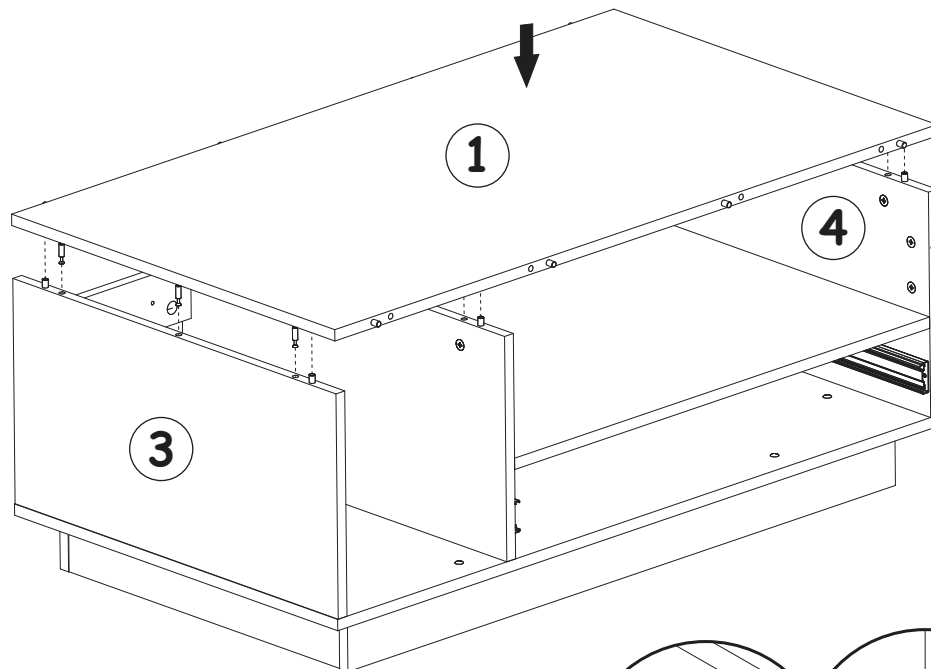

26

G5	
x12	

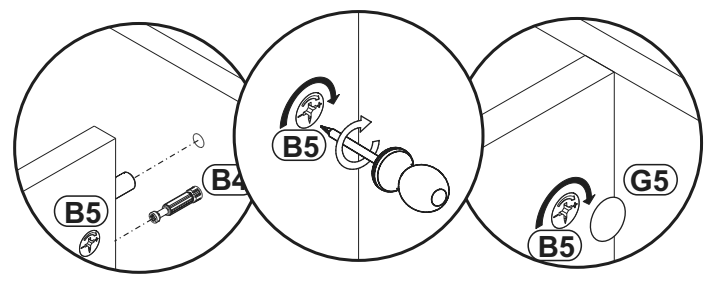
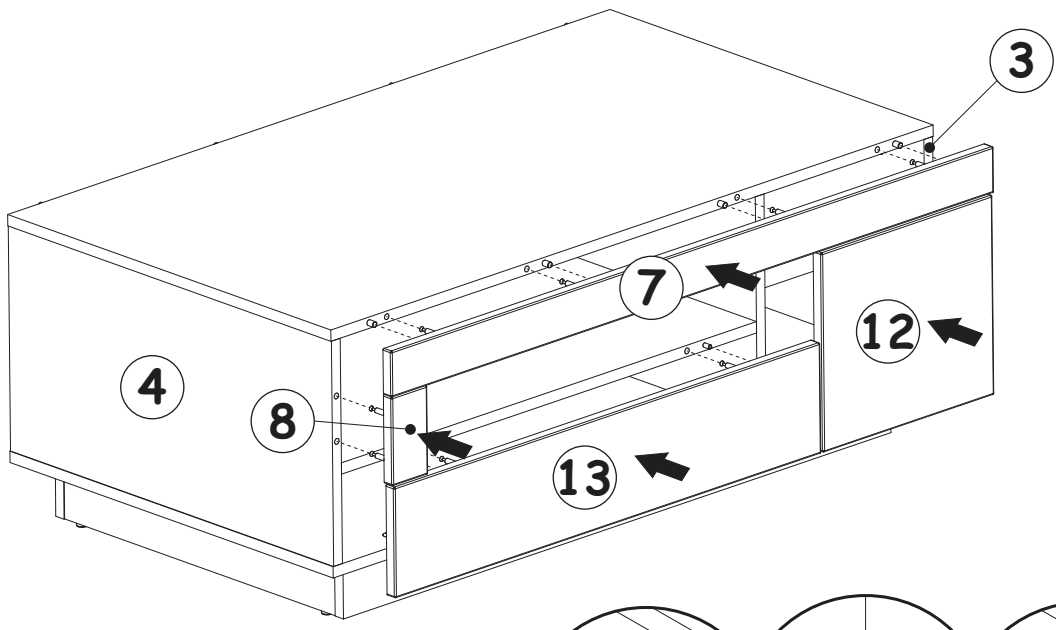

27

UP6	
x2	UPØ4x30

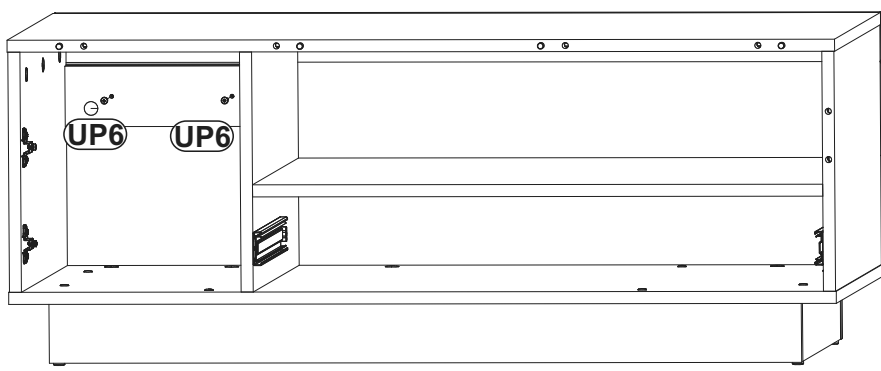

28

G5	
x6	

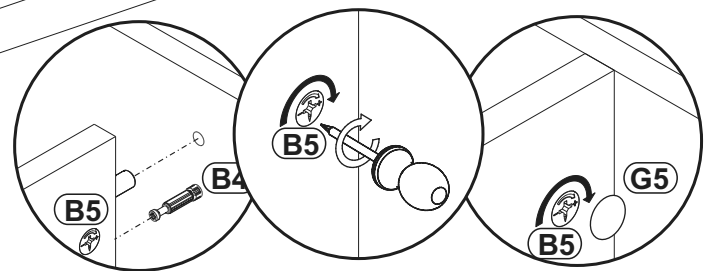
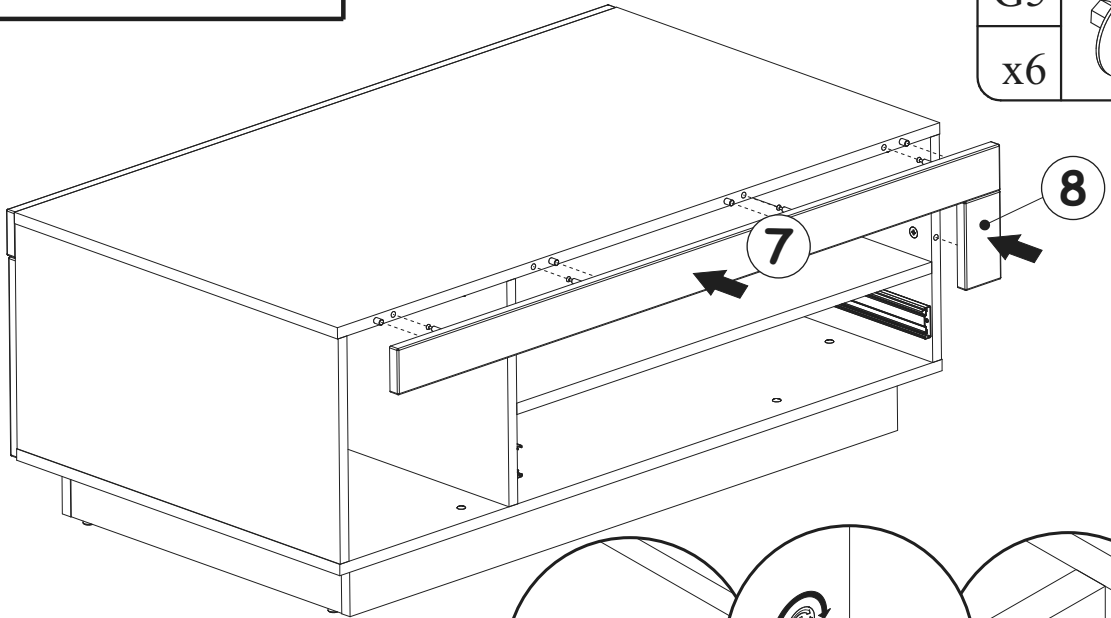

29

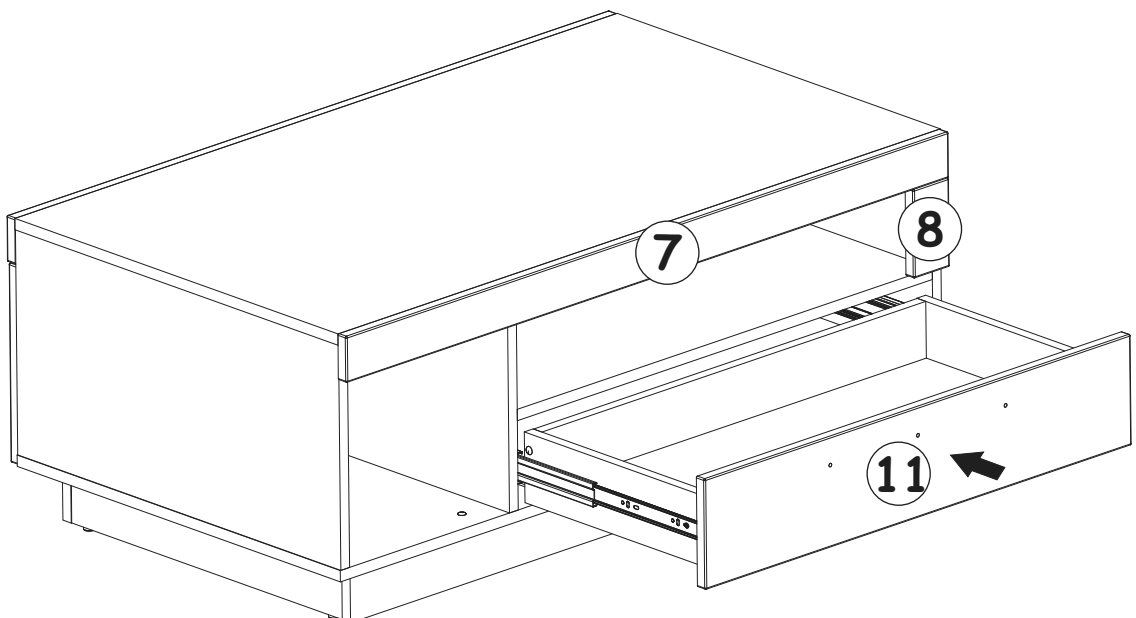
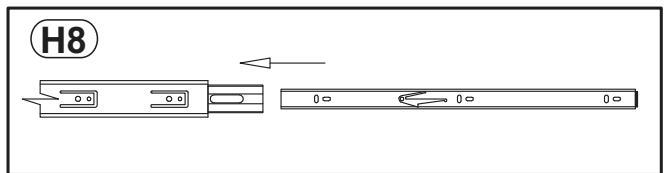

30

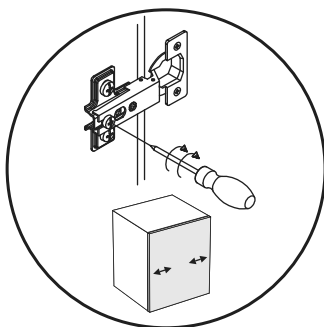
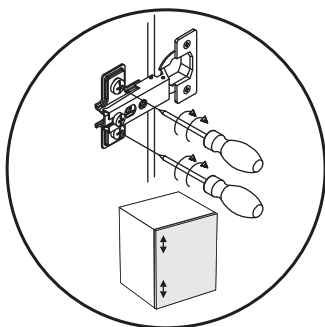
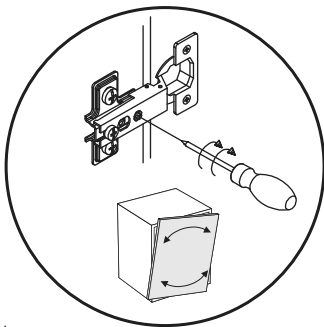
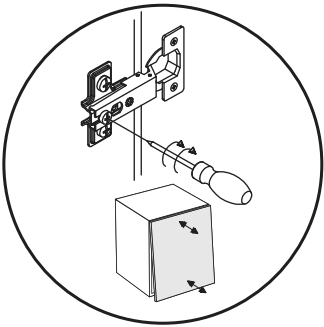
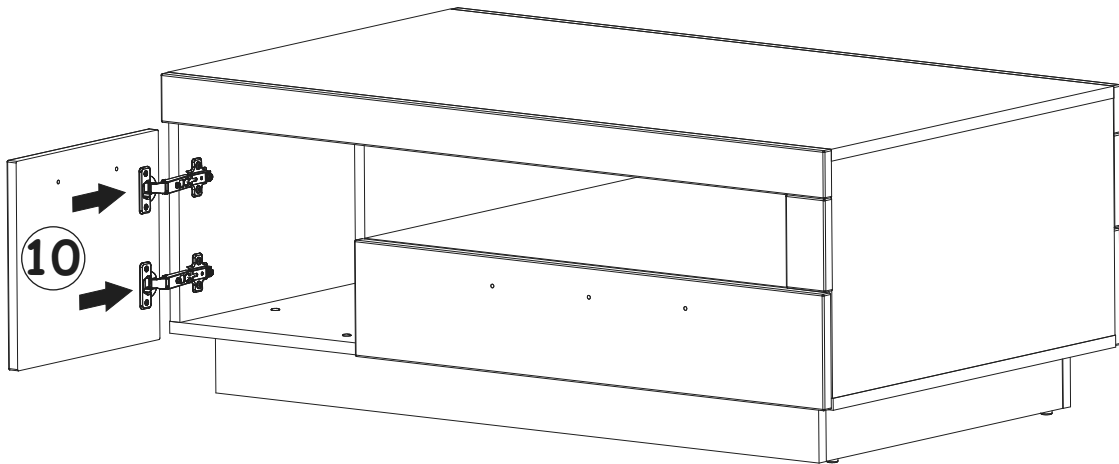

31

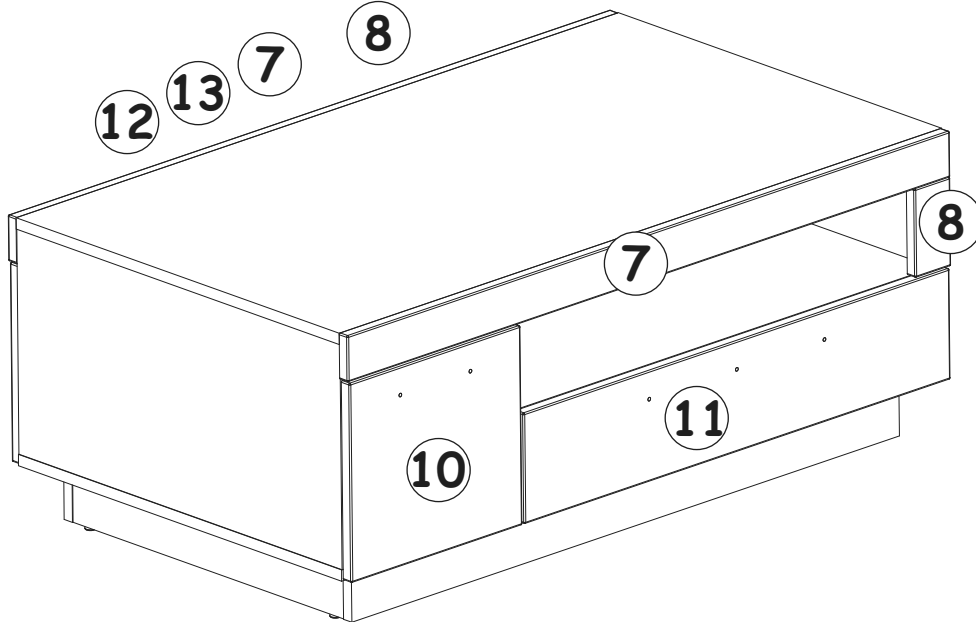

7 8 10 11 12 13

