

YORK

YORK_02

OP-28_7W ; 61

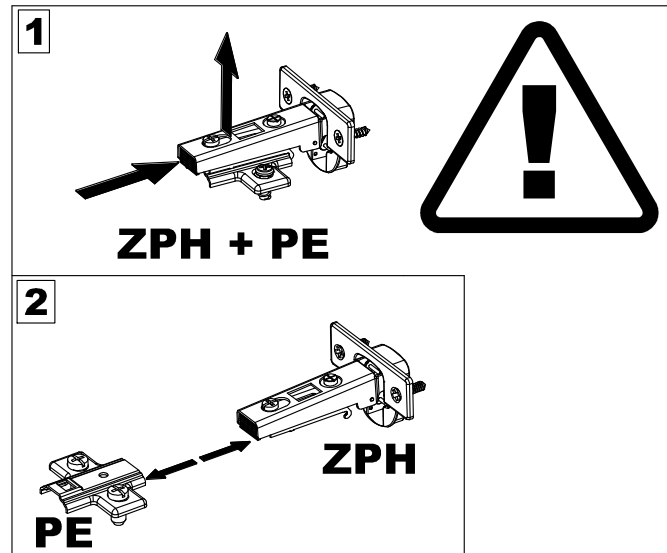
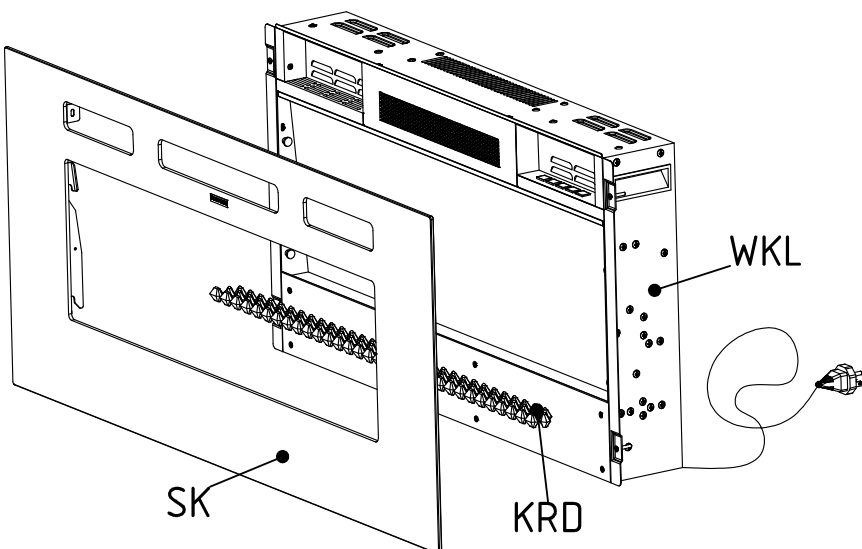
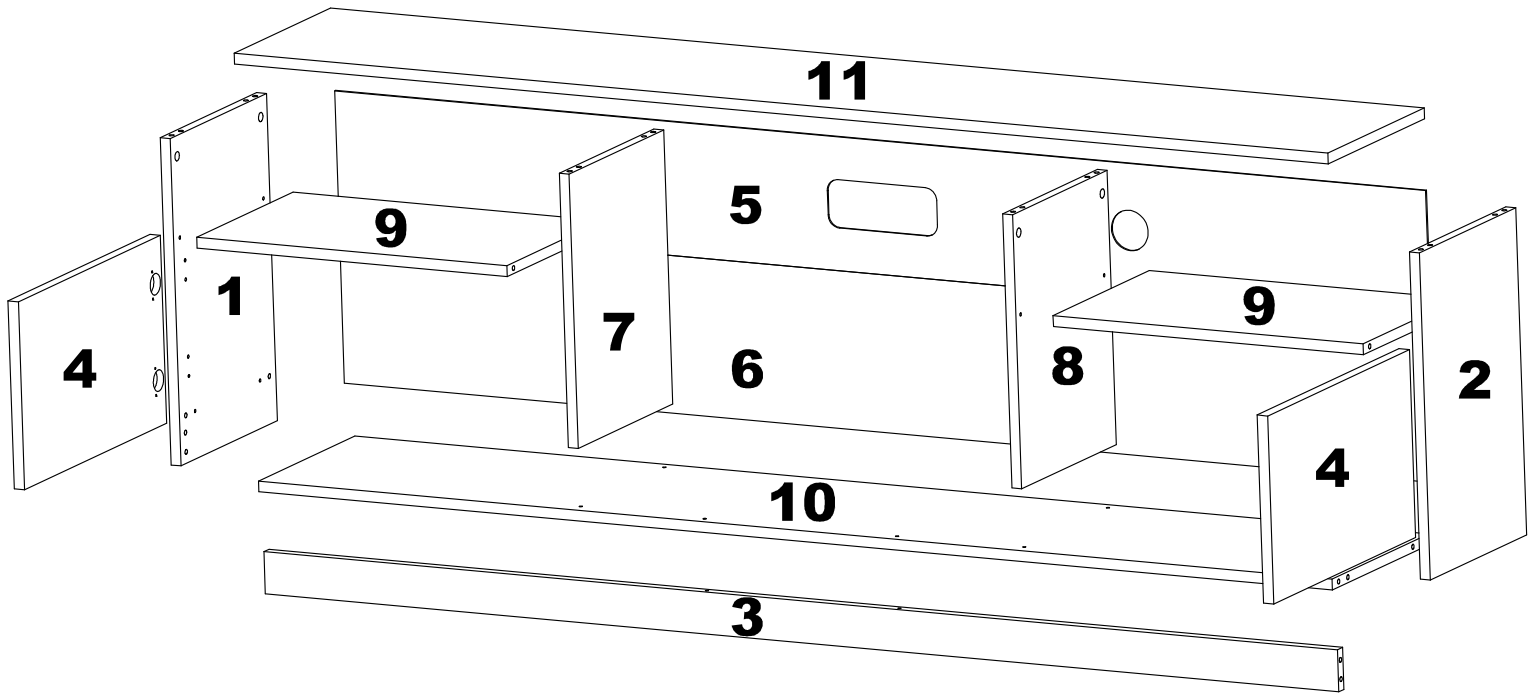
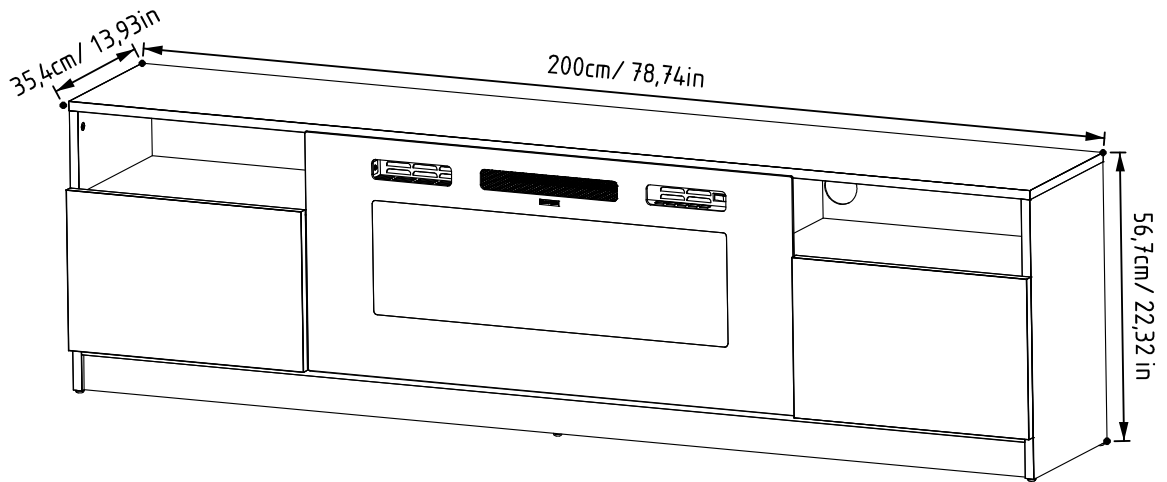
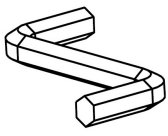
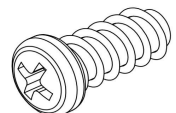
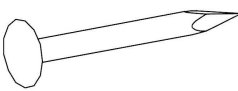
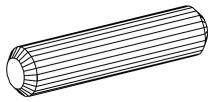
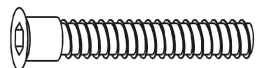

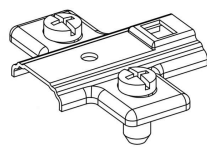
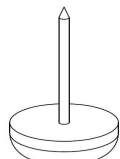
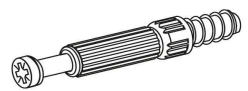

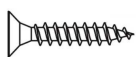
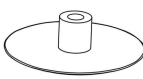
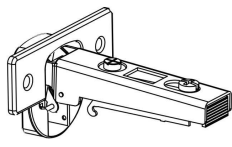
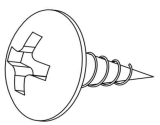
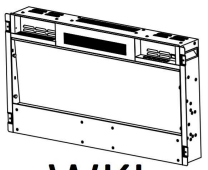
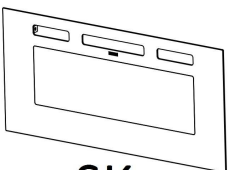
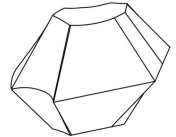
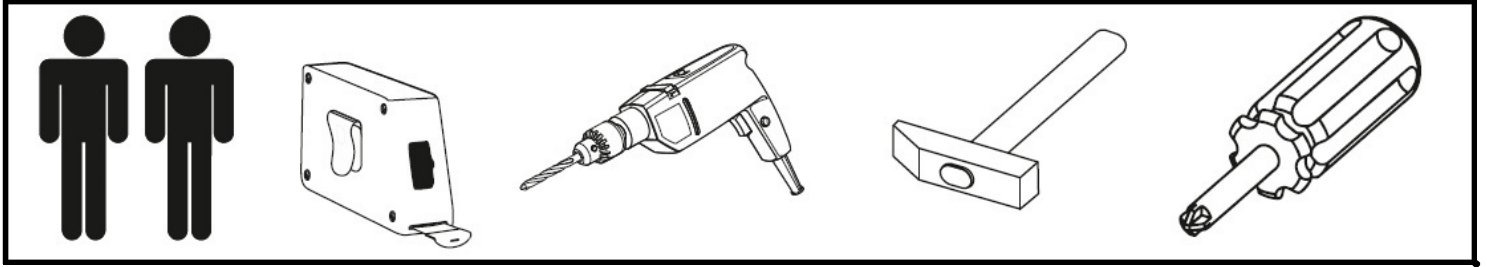
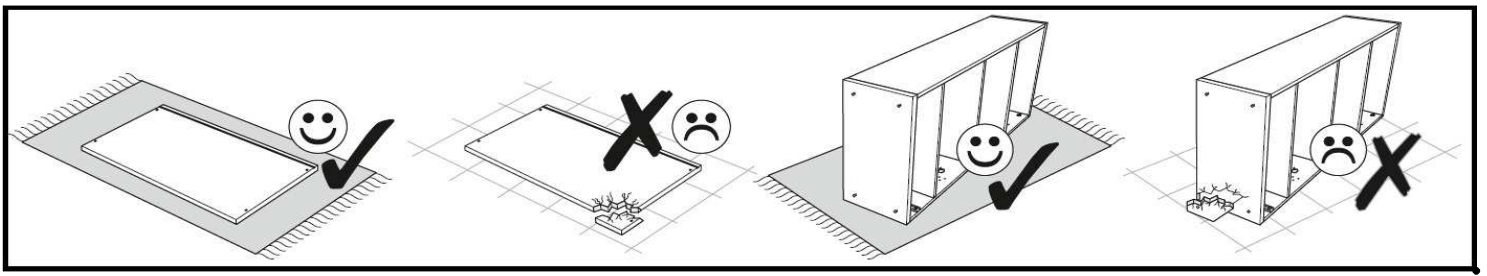

Table accessories

YORK_02

 A1	6,3 X 13  E13	 G	8 x 30  K	6,3 X 50  KN
15 x 12  M	 N8	 PE	 SL	6 x 34 mm  T
4 x 16  W16	4 X 25mm  W4	 Z	 ZPH	
 WK	 WKL	 SK	 KRD	

Elements				Accessories	
SYMBOL	LENGTH in	WIDTH in	QUANTITY	SYMBOL	QUANTITY
BL [1]	21.38	13.07	1	A1	1
BP [2]	21.38	13.07	1	E13	2
CD [3]	77.28	2.76	1	G	50
FT [4]	19.25	12.28	2	K	16
PC1 [5]	78.54	10.32	1	KN	6
PC2 [6]	78.54	8.78	1	KRD (attached to the electric fireplace)	145
PPI01 [7]	17.91	12.84	1	M	20
PPI02 [8]	17.91	12.84	1	N8	1
PPO [9]	22.32	13.07	2	PE	4
WD [10]	77.28	13.07	1	SK (attached to the electric fireplace)	1
WG [11]	78.74	13.07	1	SL	5
				T	20
				W16	8
				W4	4
				WK (attached to the electric fireplace)	6
				WKL (attached to the electric fireplace)	1
				Z	20
				ZPH	4



1.

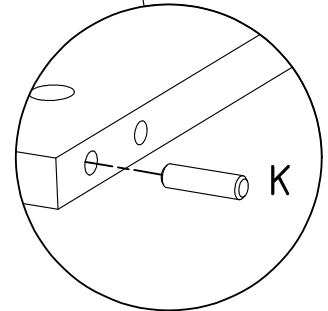
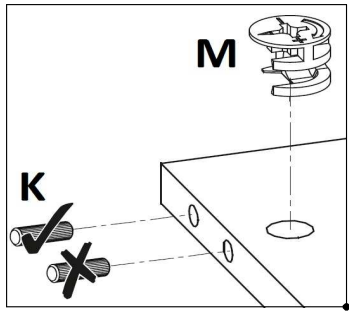
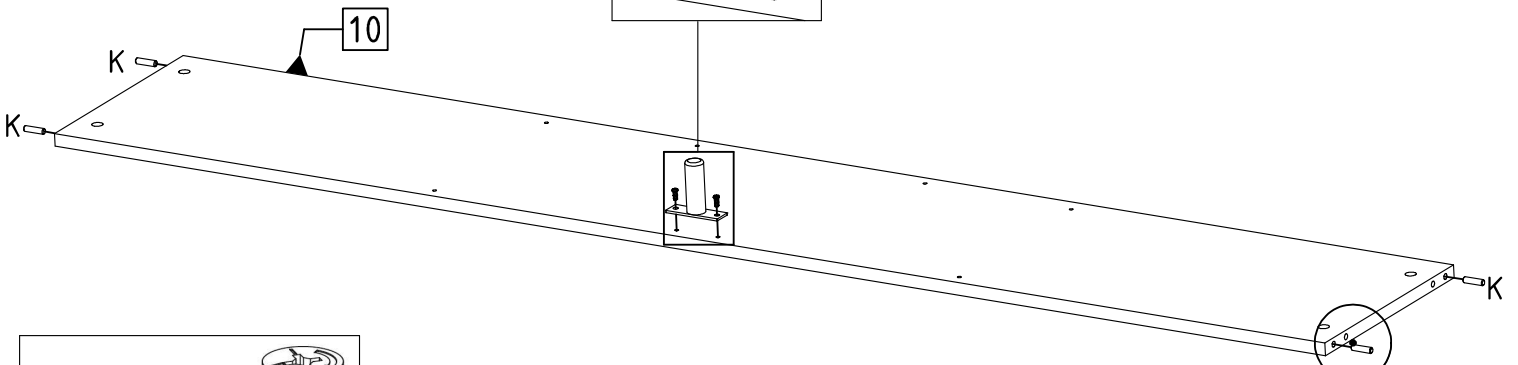
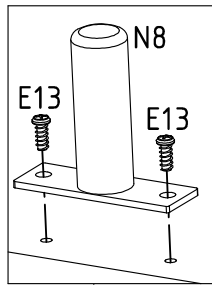

2.

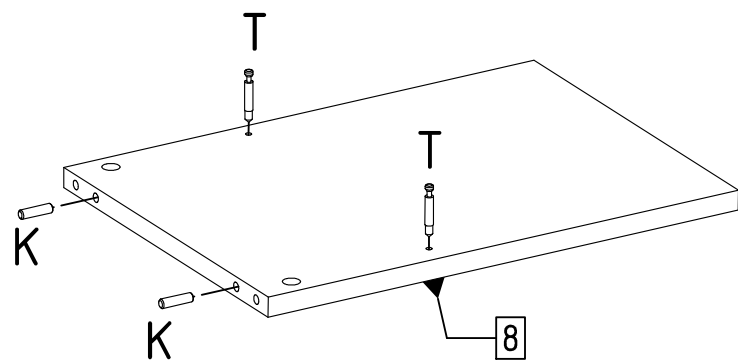
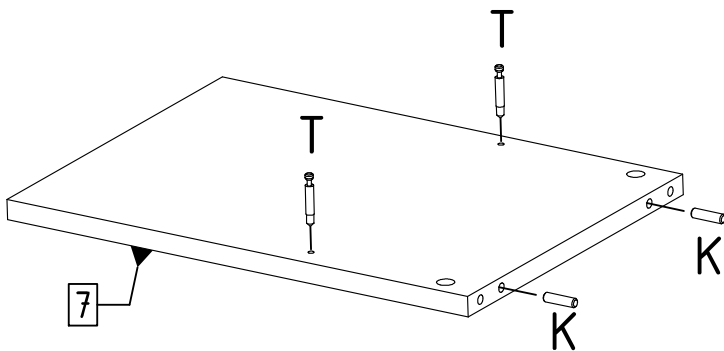

3.

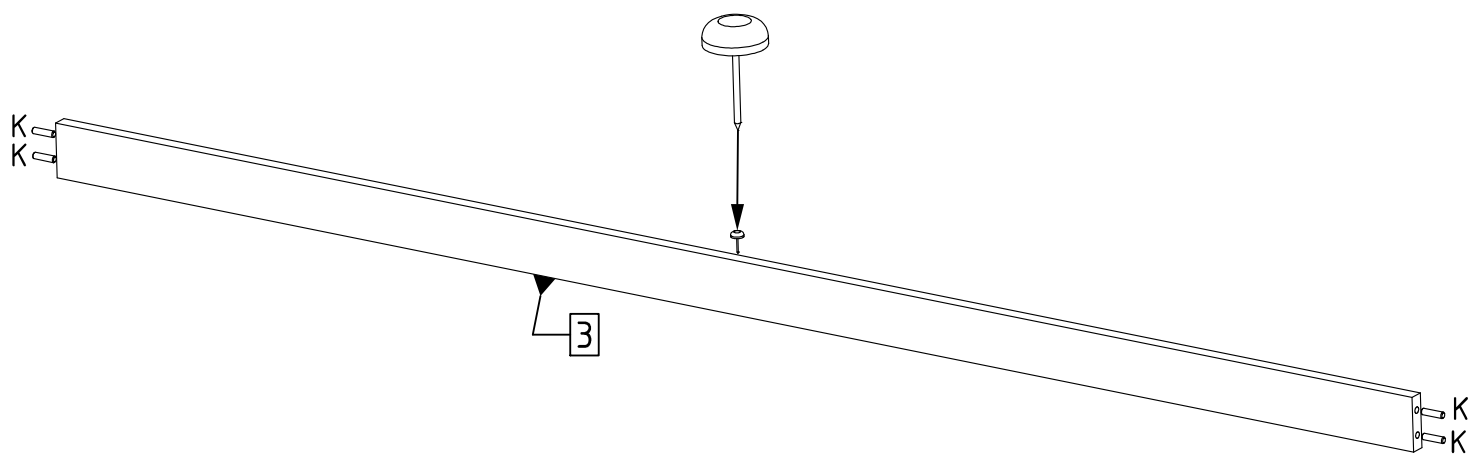
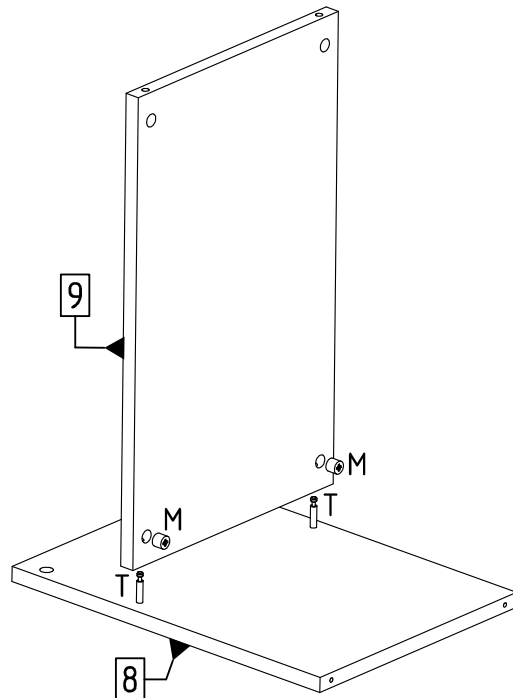
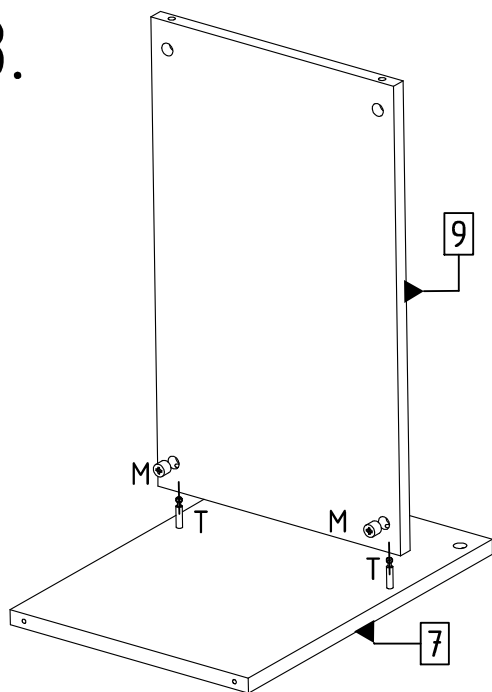

4.

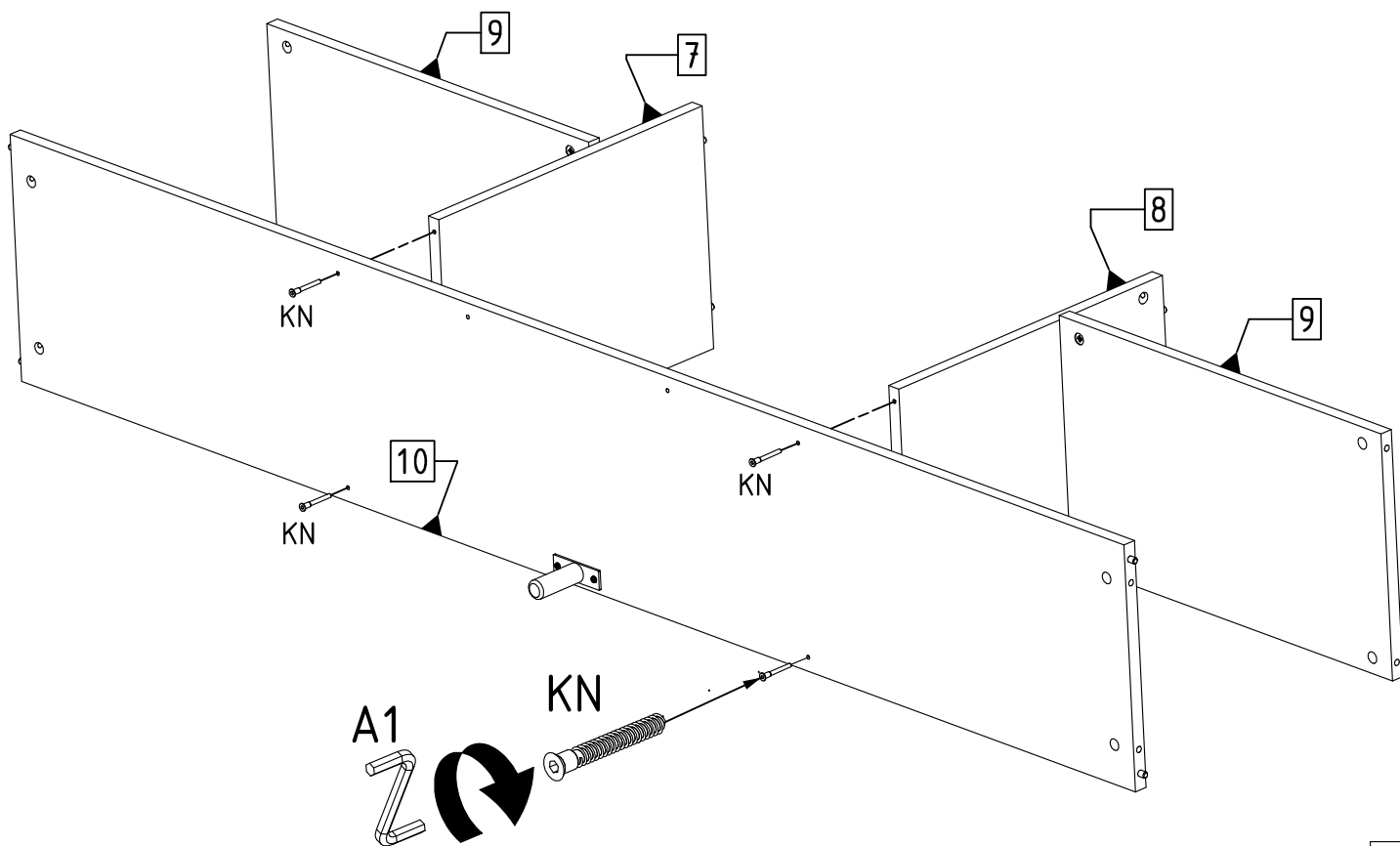

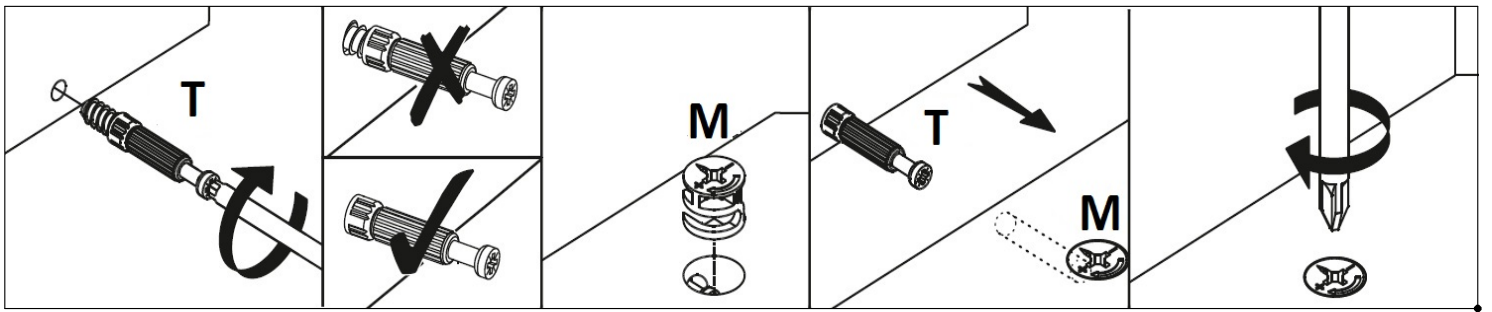

5.

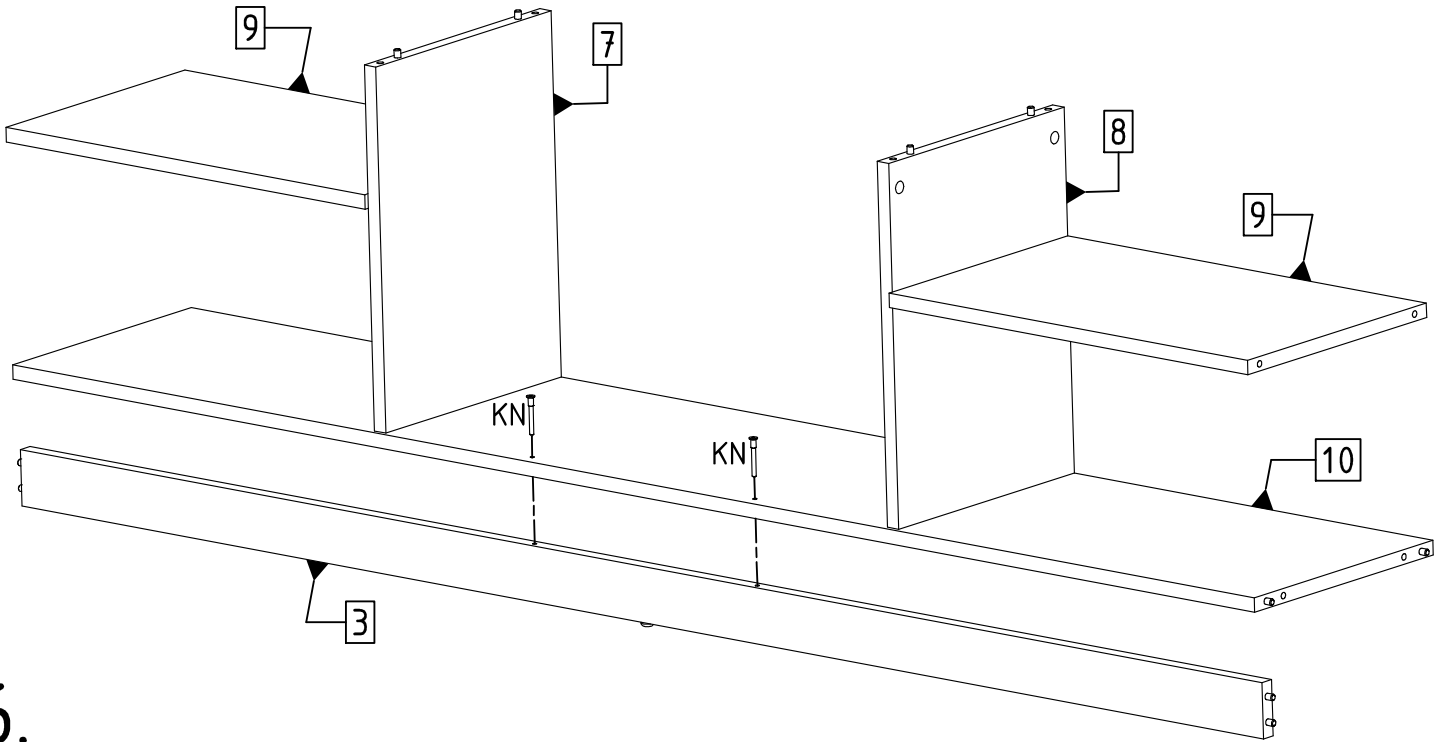

6.

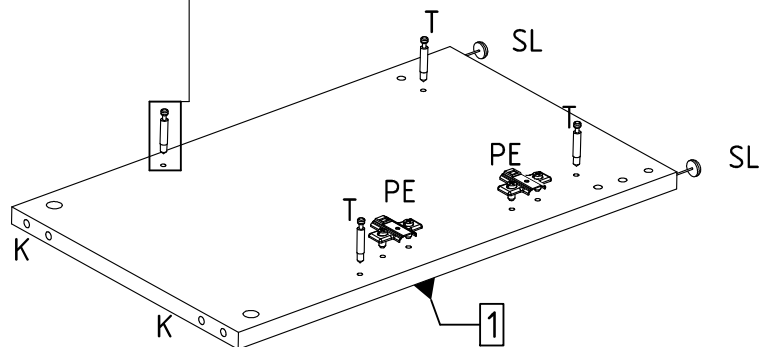
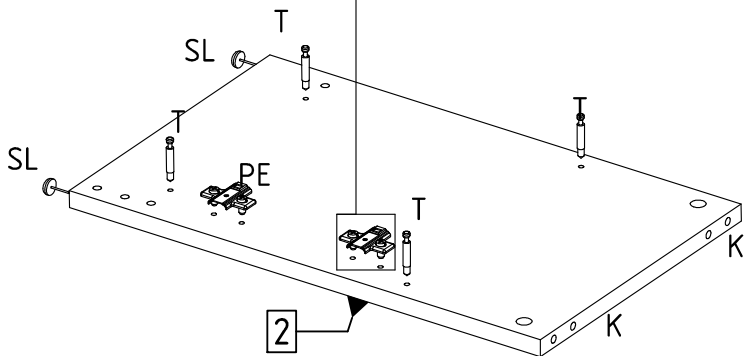
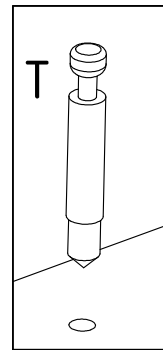
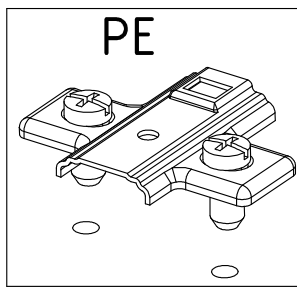

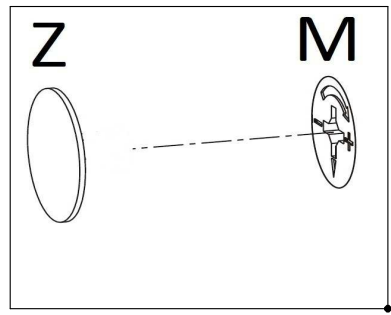
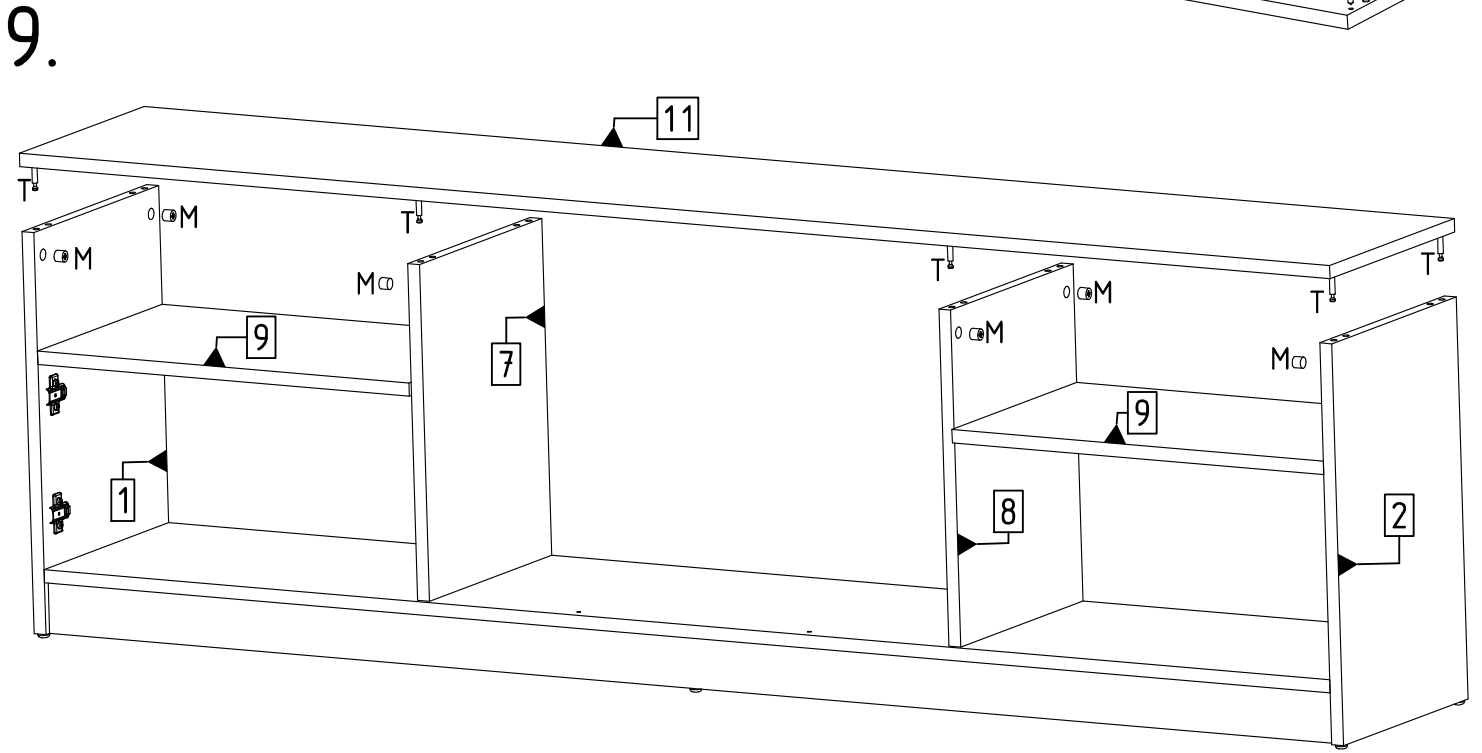
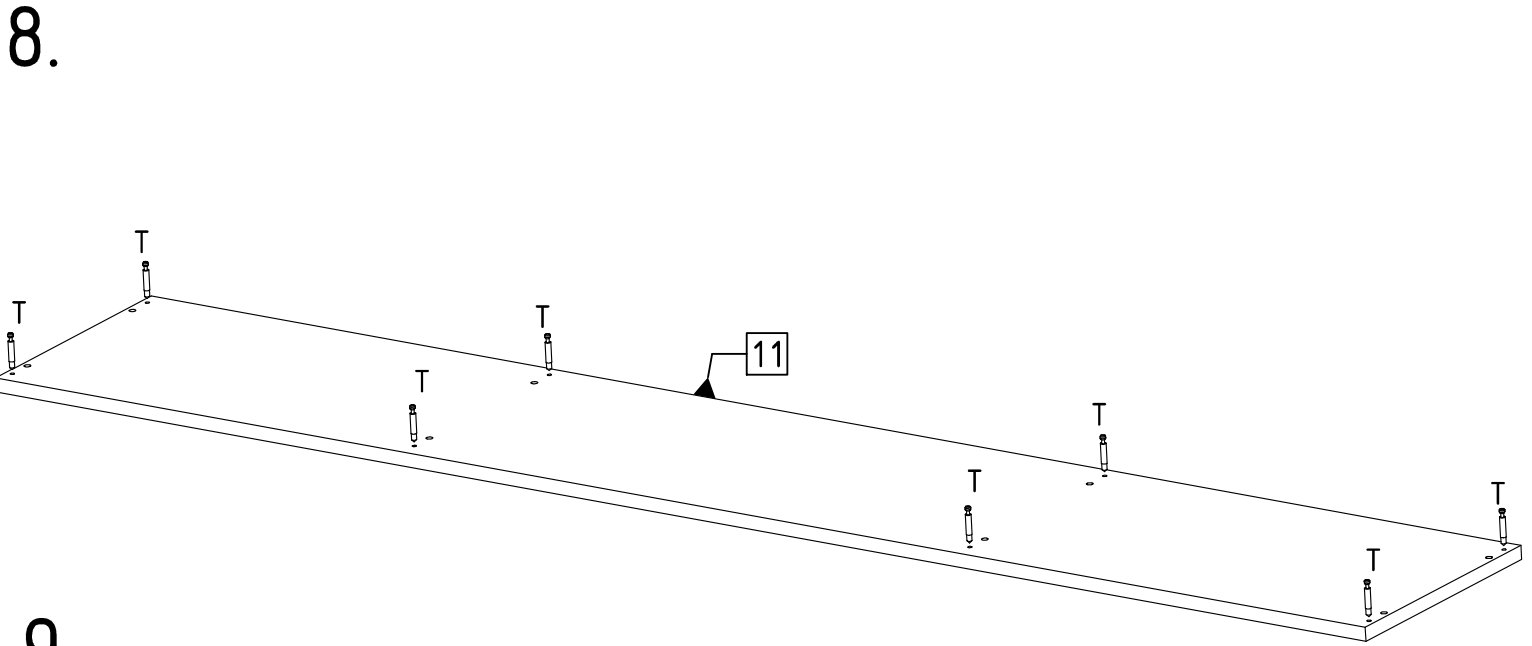
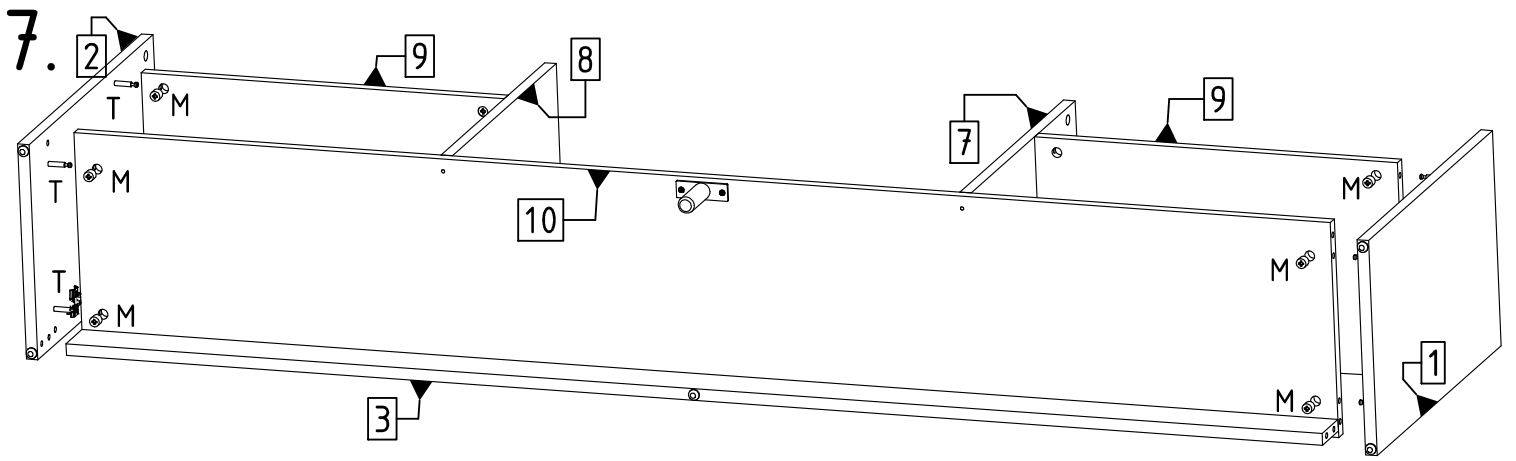

10.

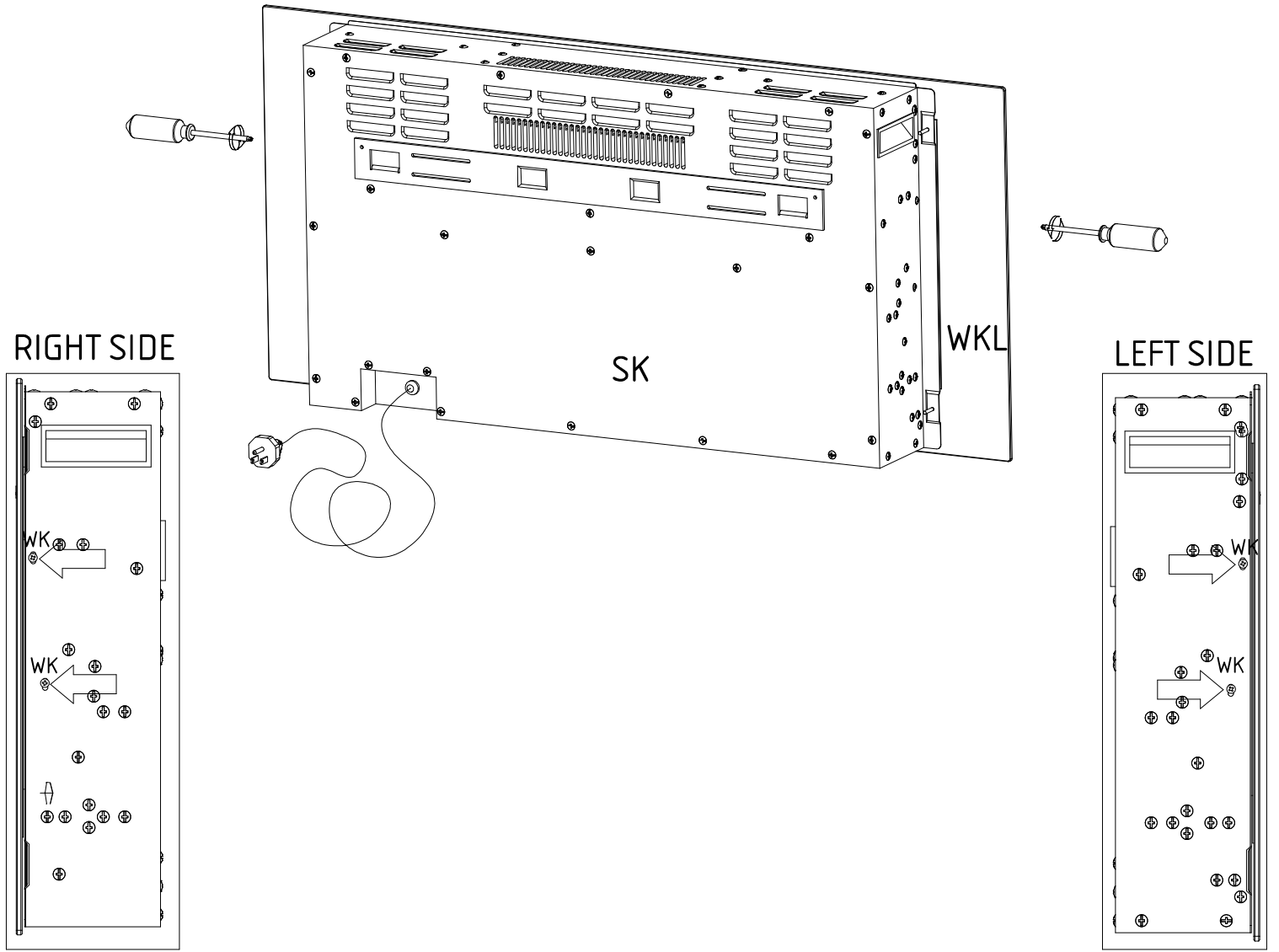

11.

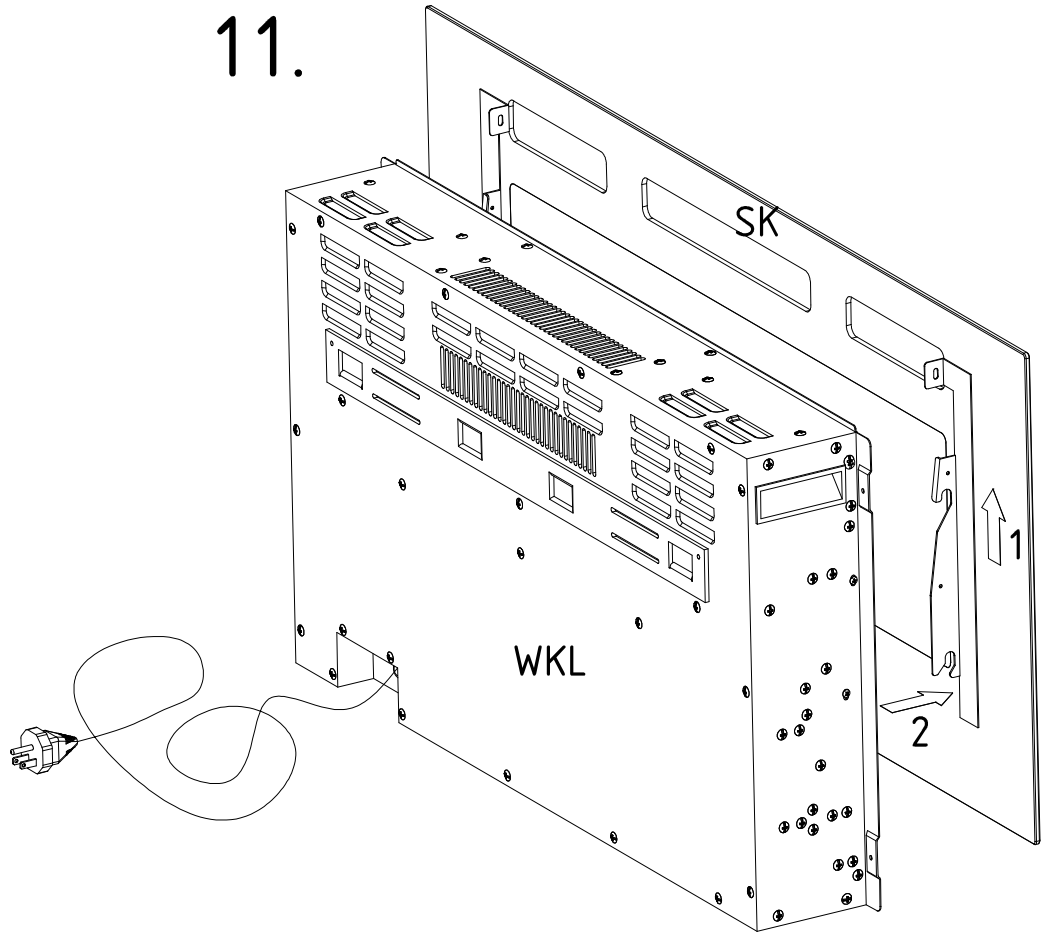

12.

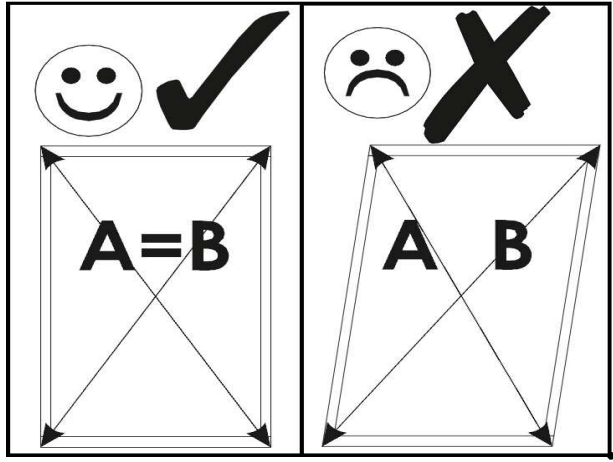
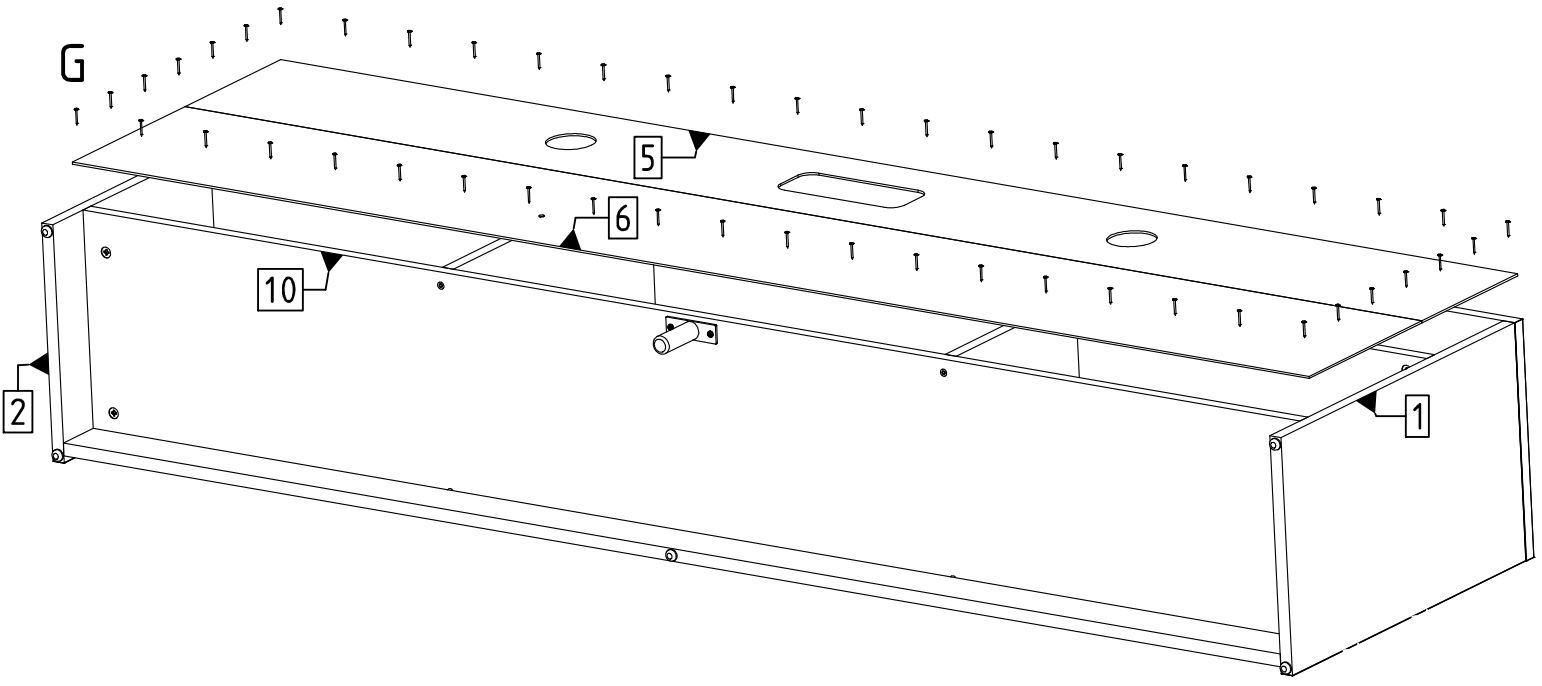

13.

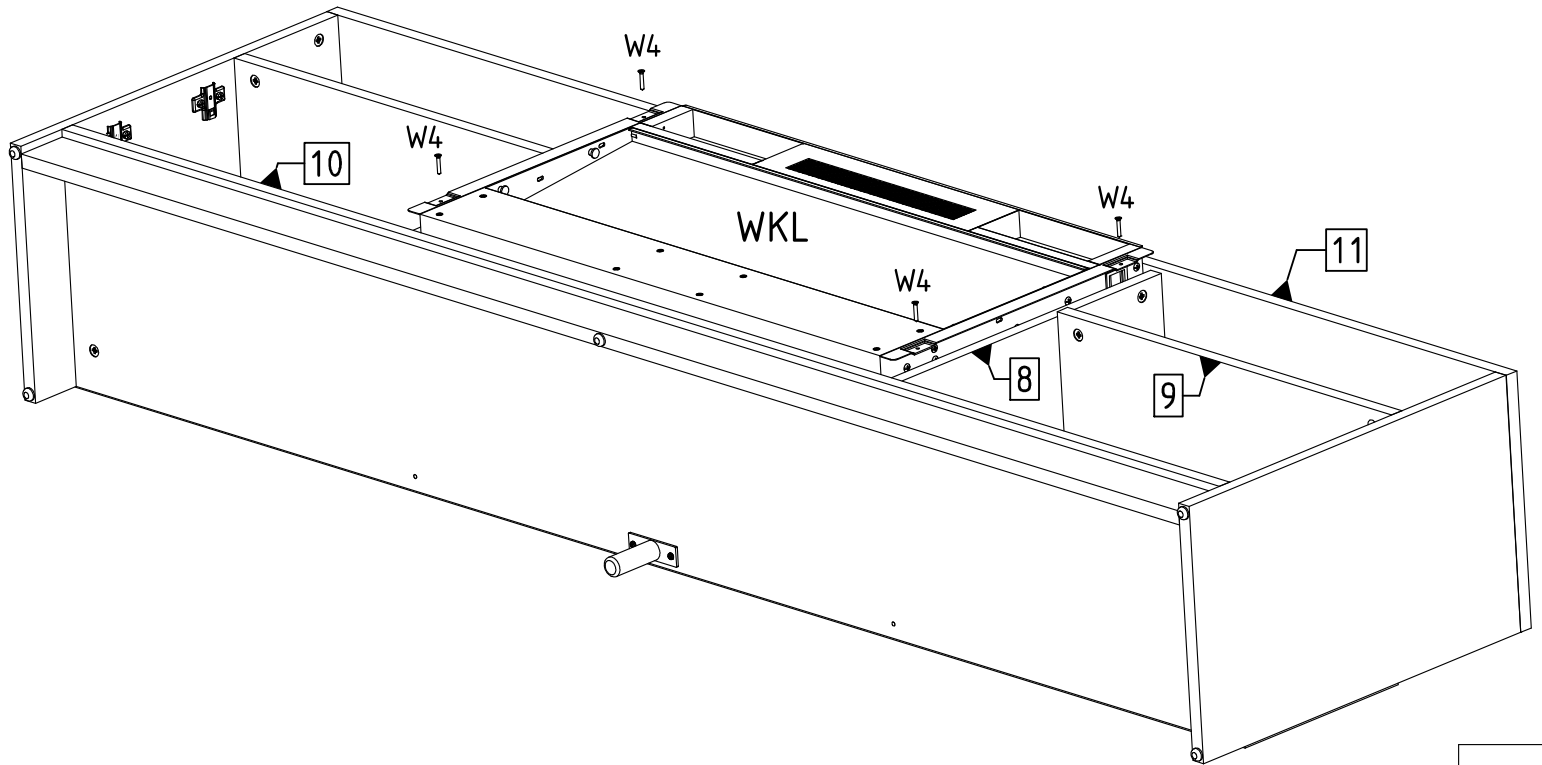

14.

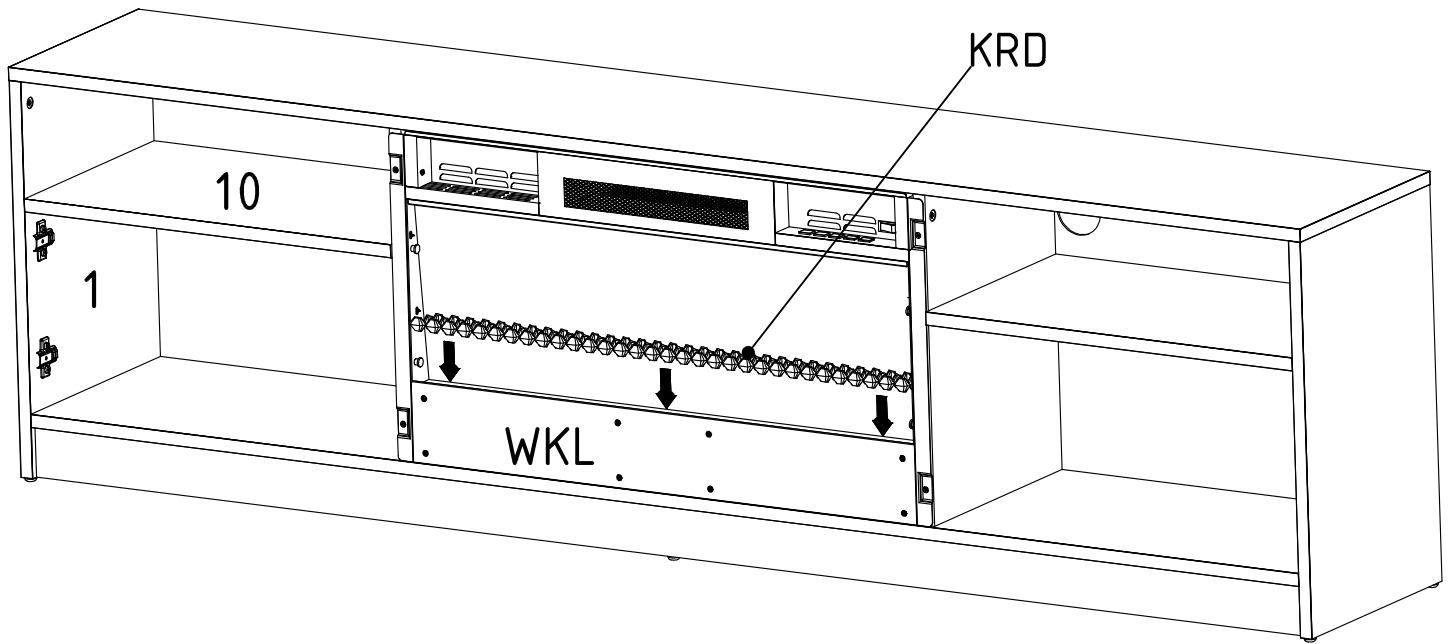

15.

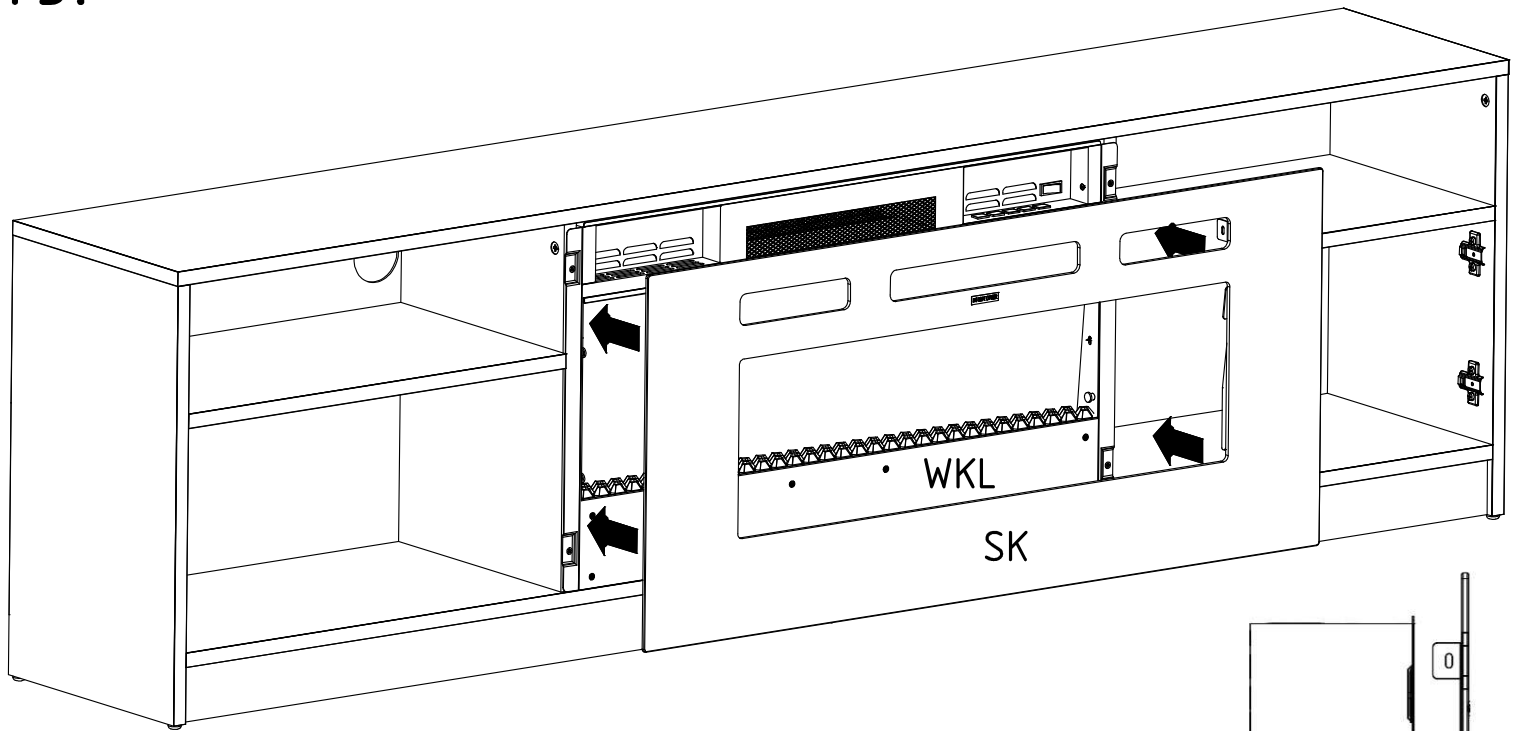

16.

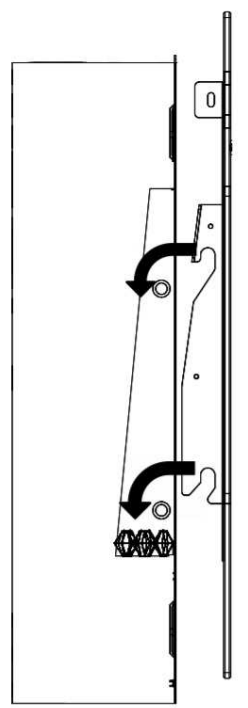
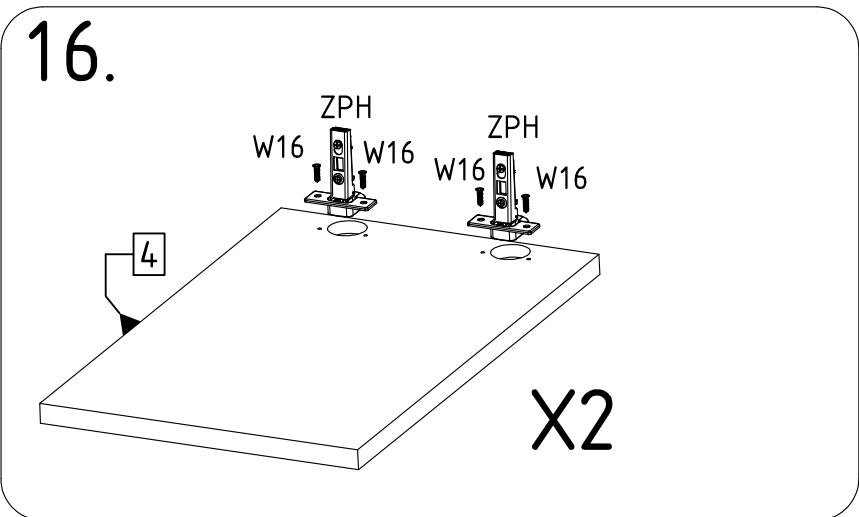

17.

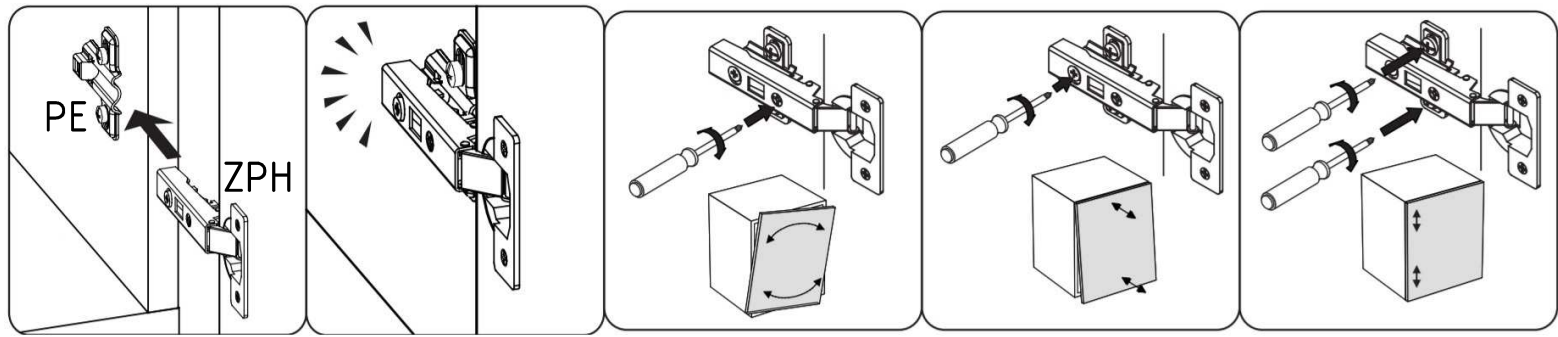
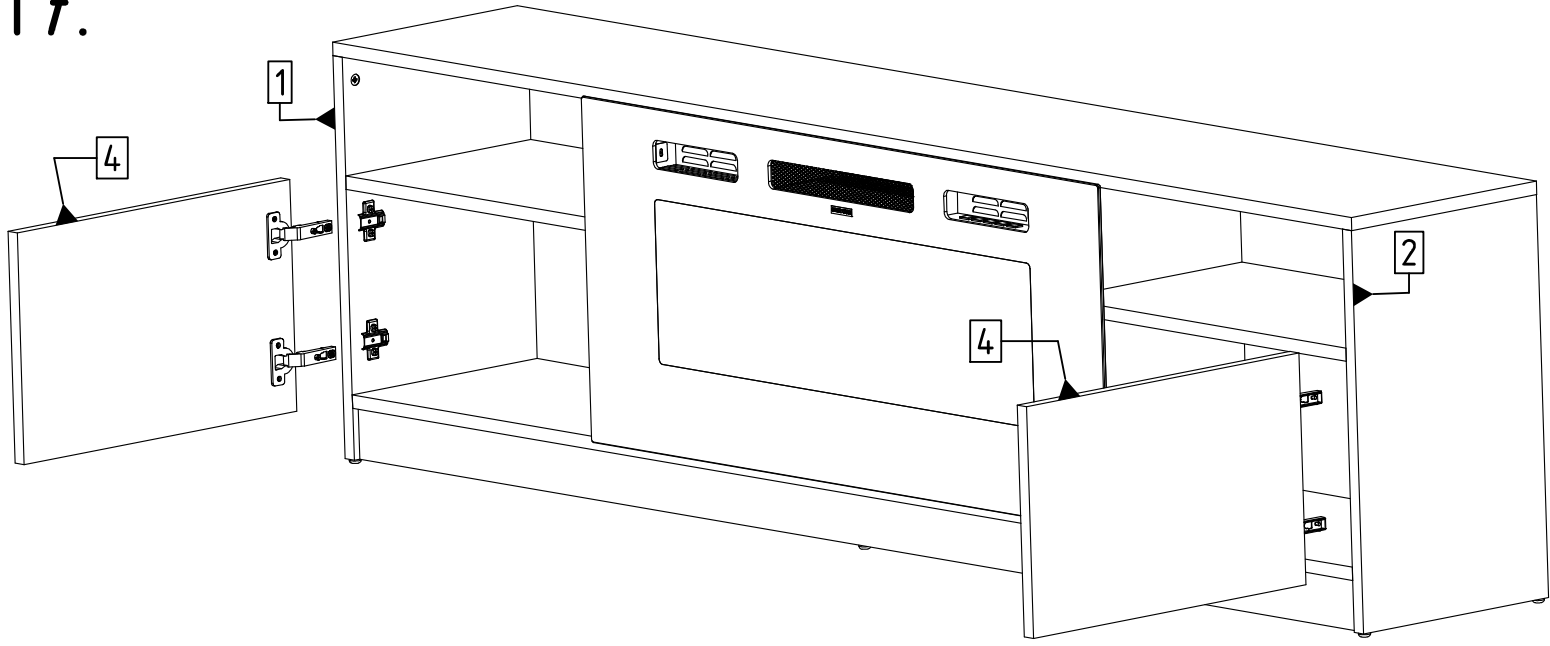

18.

LED UNDER TOP

