

WOOD

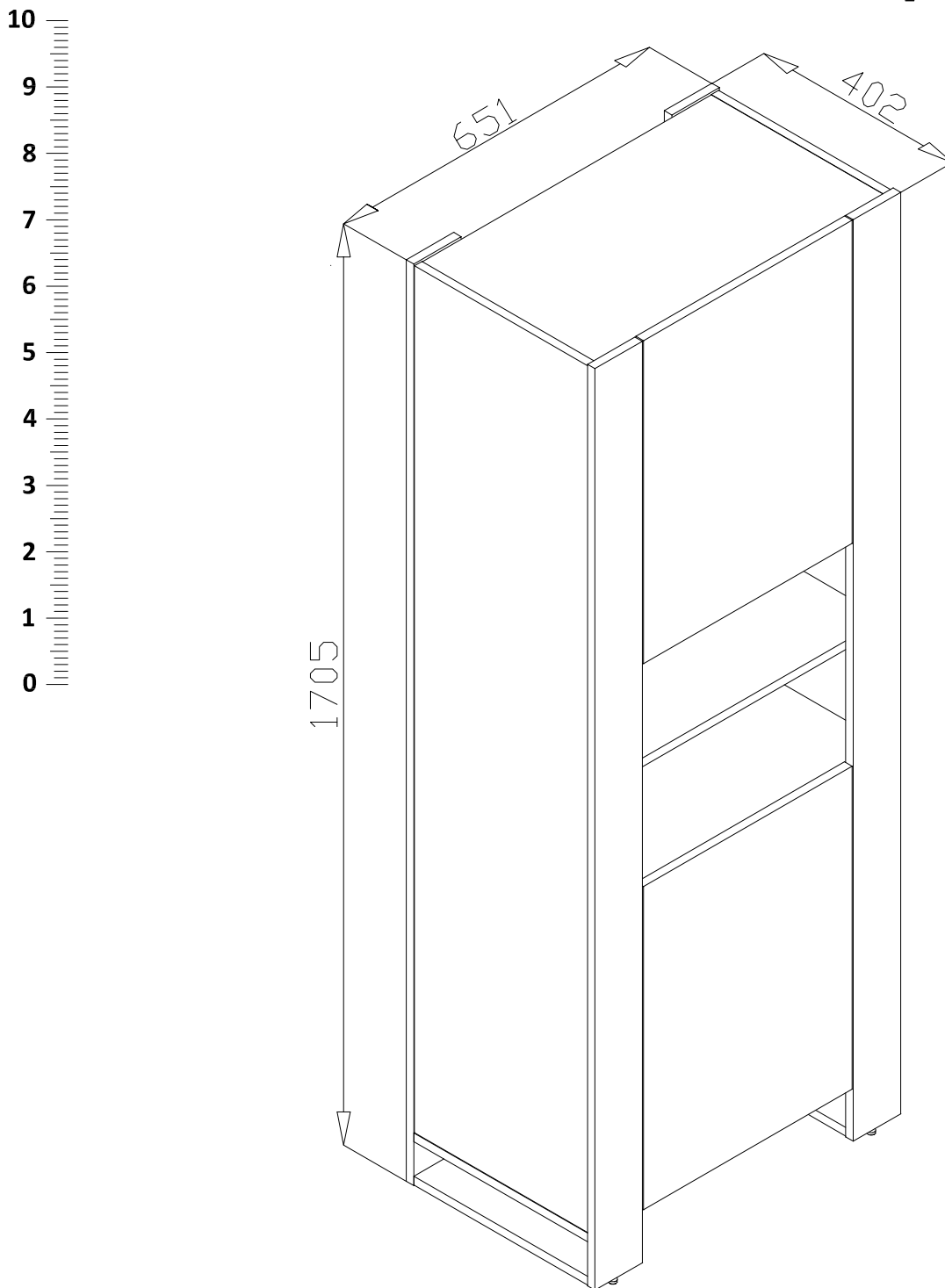

PL- Narzędzia niezbędne do montażu (nie dostarczone przez producenta)/ DE- Für die Montage notwendige Werkzeuge (nicht vom Hersteller mitgeliefert)/ EN- Tools required for assembly (not provided by the manufacturer)/ CZ- Nástroje nezbytné pro montáž (nejsoú dodávány výrobcem)/HR- Alat potreban za montažu (nije osiguran od strane proizvođača)

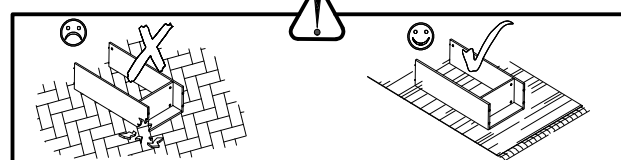

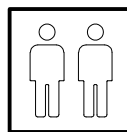
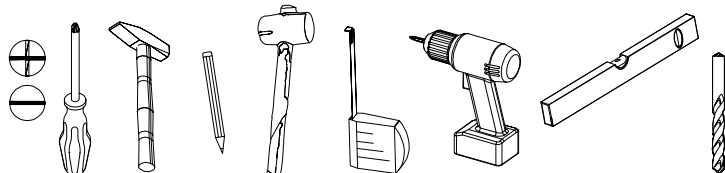
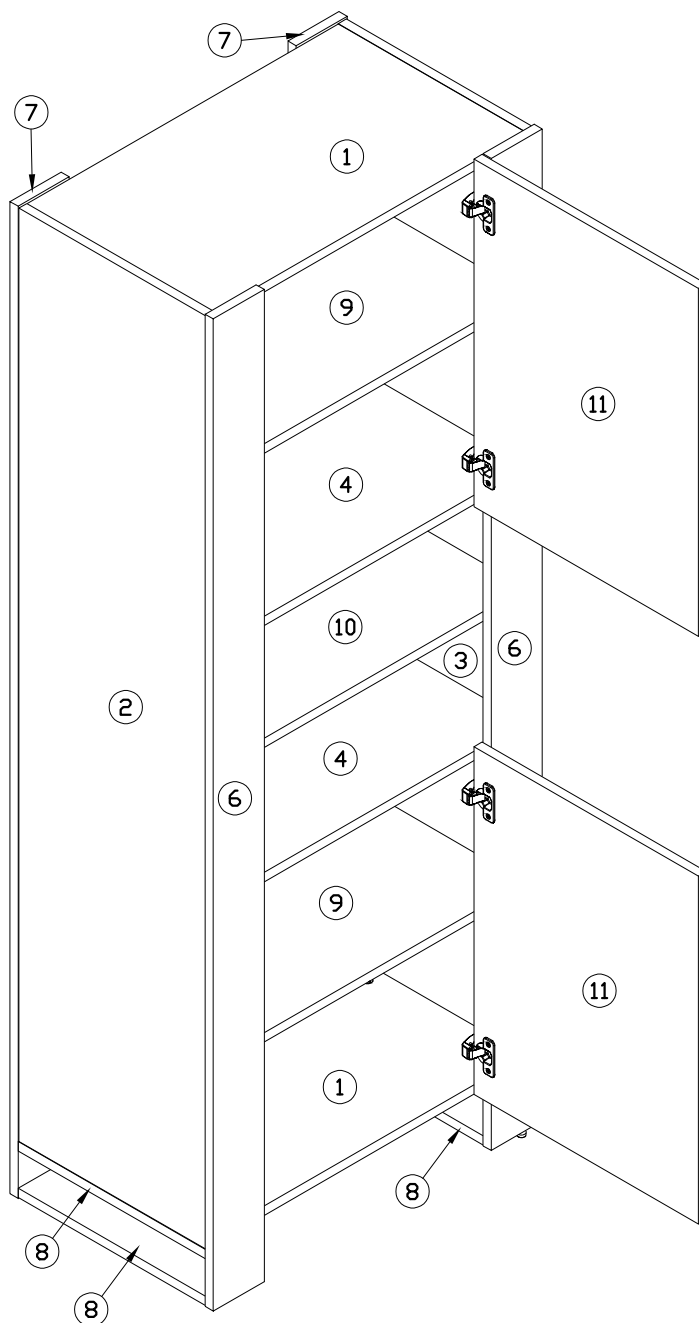

#	X mm	Y mm	Z mm	Q
1	616	370	16	2
2	1599	370	16	1
3	1599	370	16	1
4	616	350	16	2
5	616	94	16	1
6	1700	101	16	2
7	1700	101	16	2
8	370	100	16	4
9	616	350	16	2
10	616	350	16	1
11	444	596	16	2
12	437	630	3	1
13	570	315	3	4

B40 x1	B6 x6	H4 x8	K32 ø8x32 x36	K33 x4	L1 x1	N43 x4	P1 ø5x16 x12	R1 ø15x12,5 x24	R28 x24
V12 ø8 x2	W1 x4	W12 ø4x30 x6	W47 ø3,5x18 x6	W48 ø4x13 x16	Z1 ø20 x20	V12 ø8 x2	Z120 x4	Z121 x4	

1

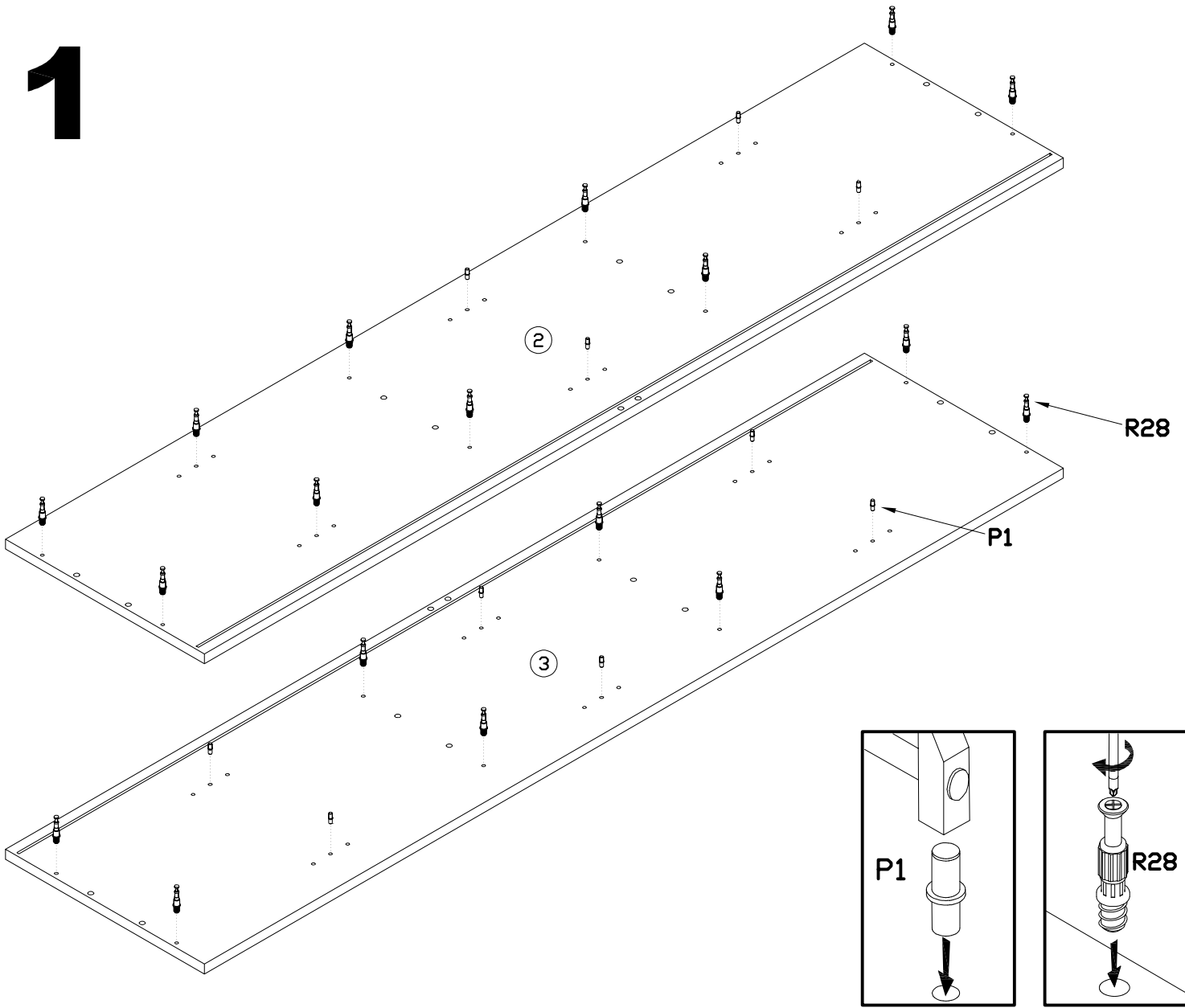

2

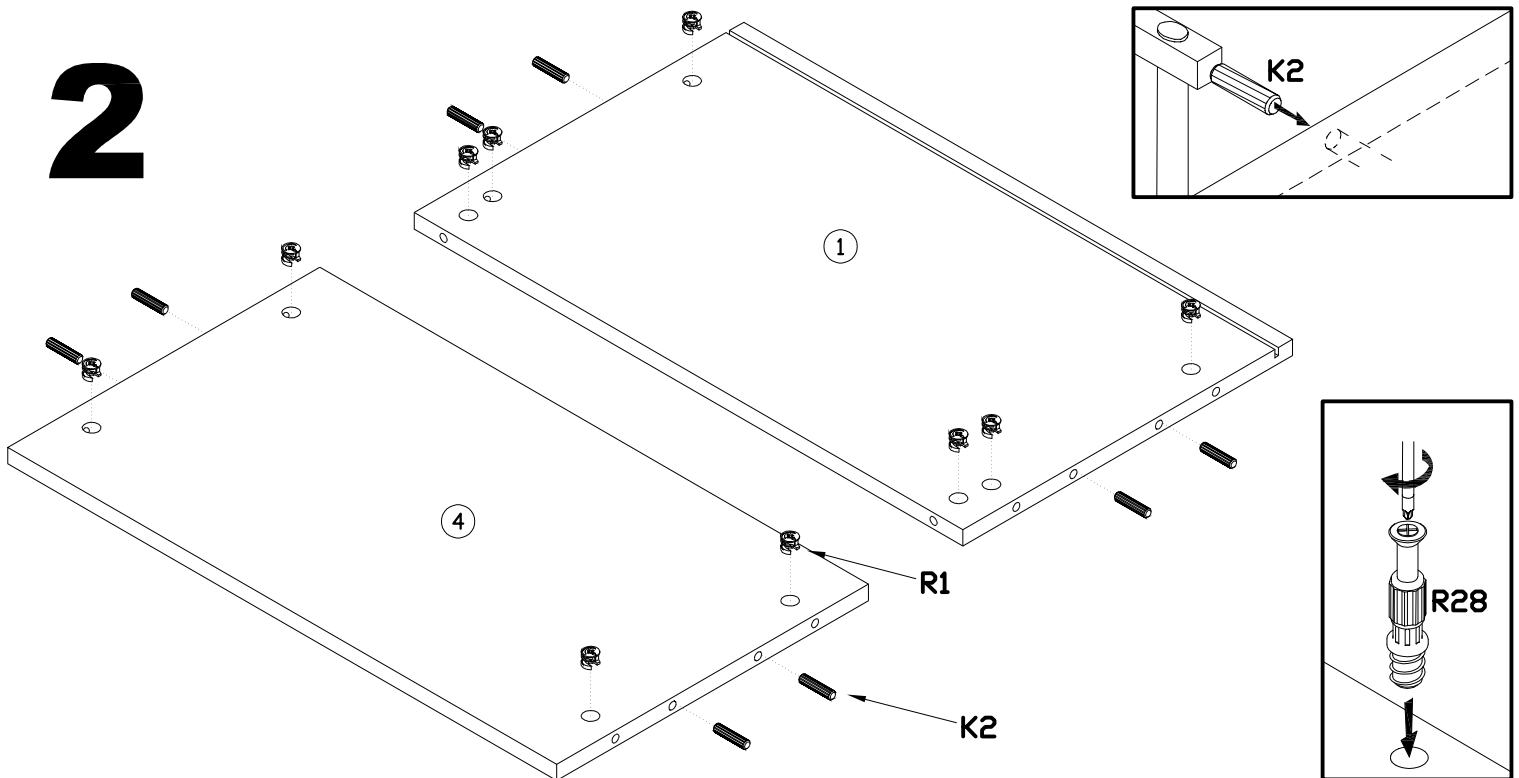

3

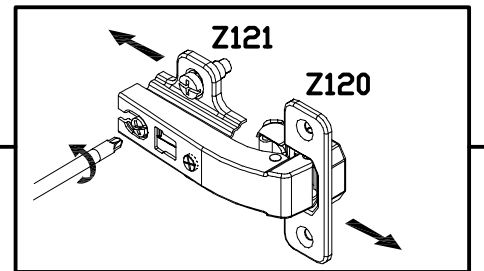
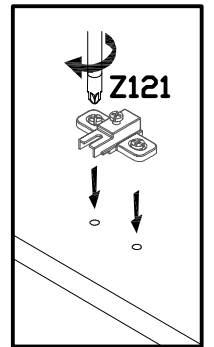
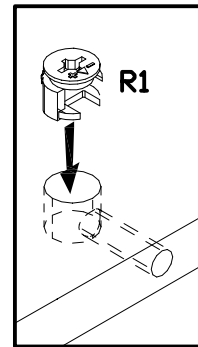
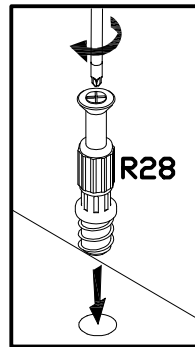
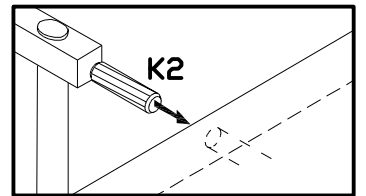
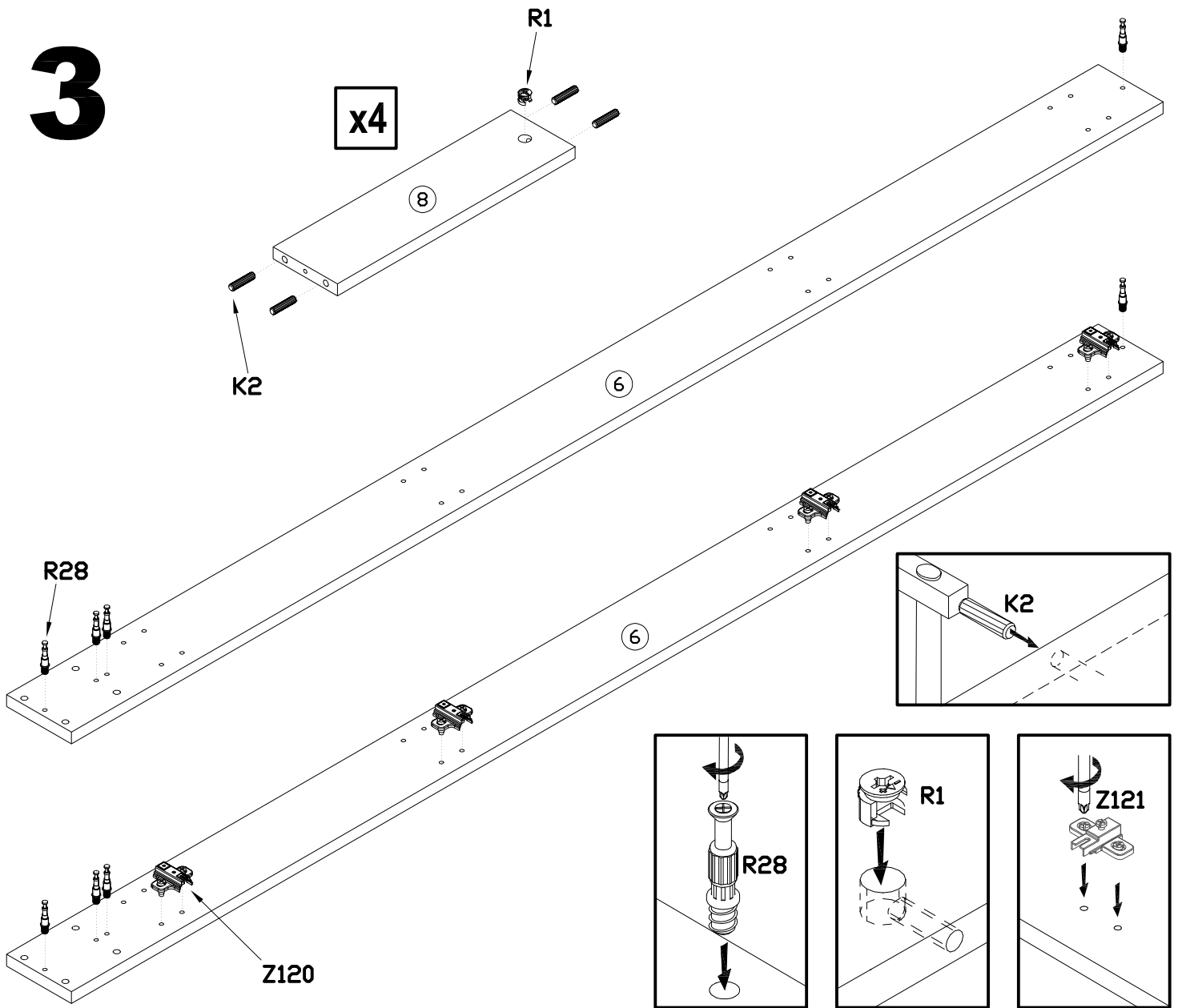

4

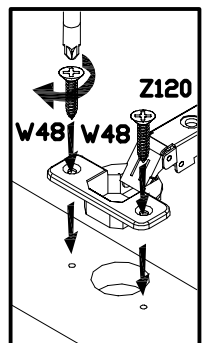
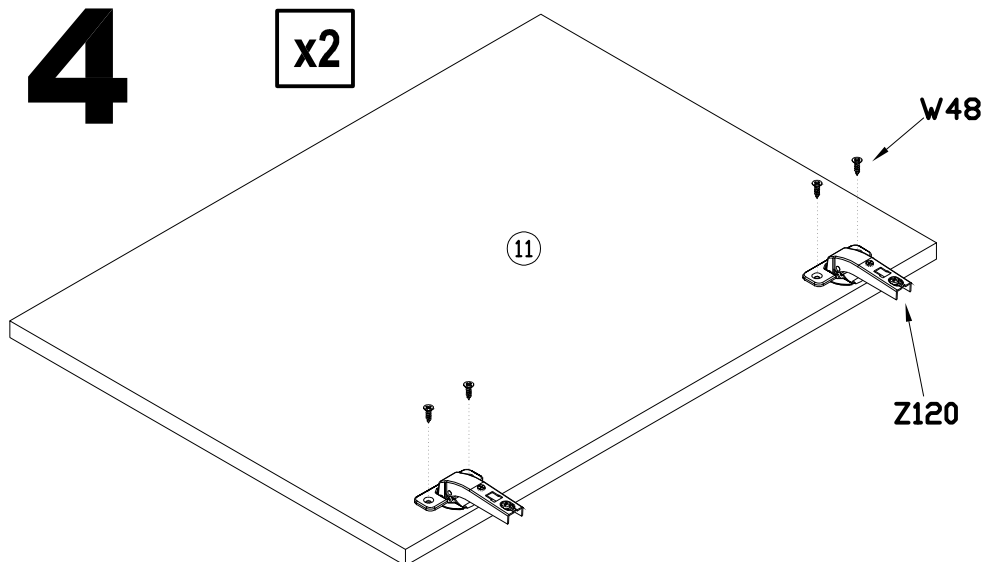

5

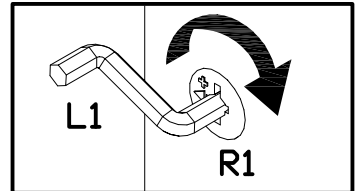
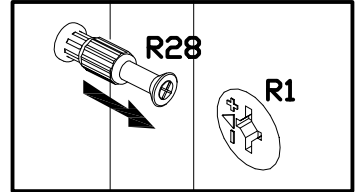
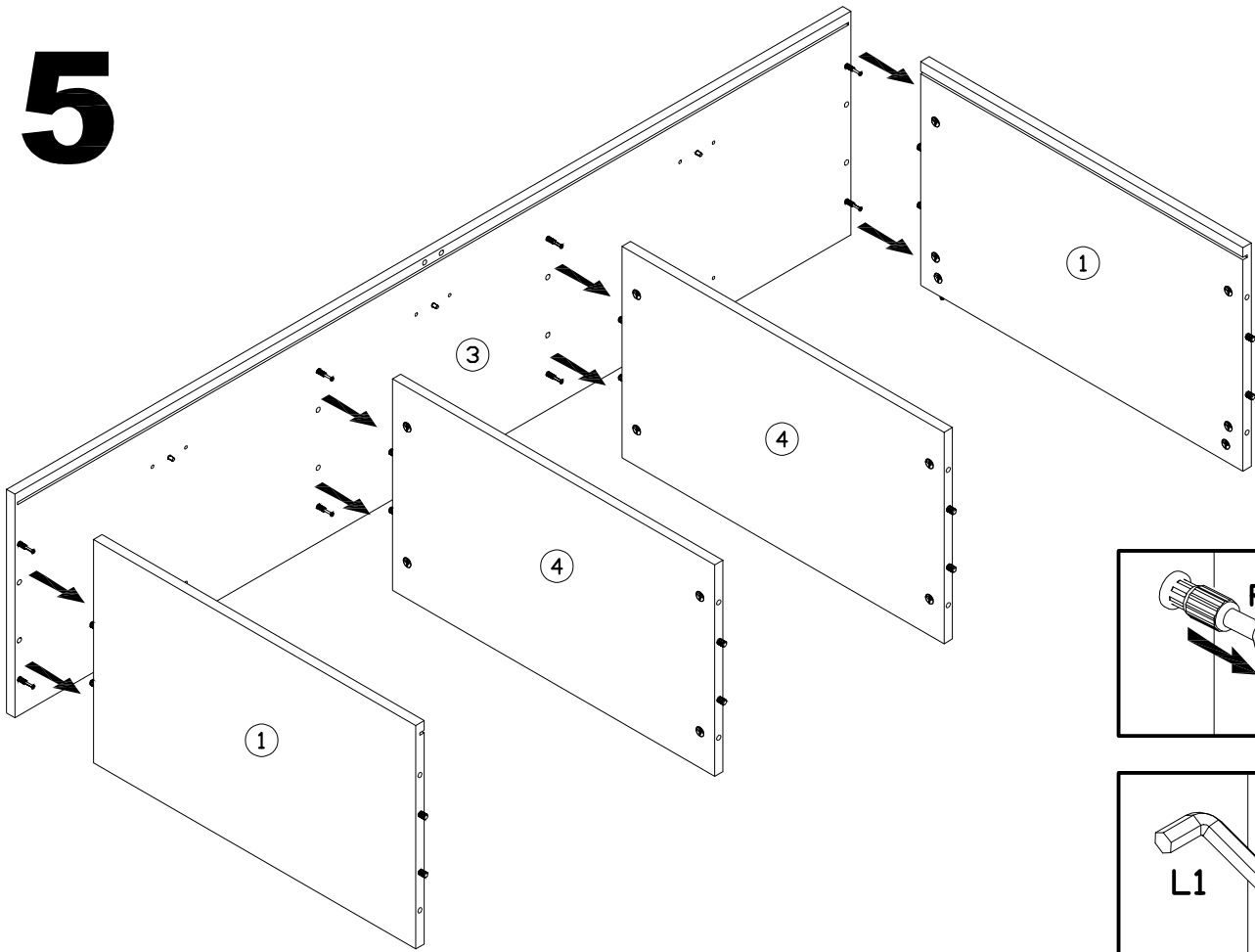

6

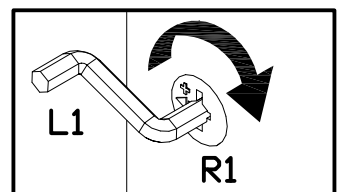
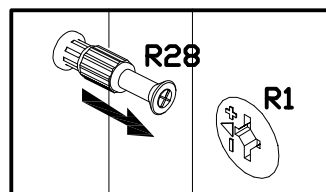
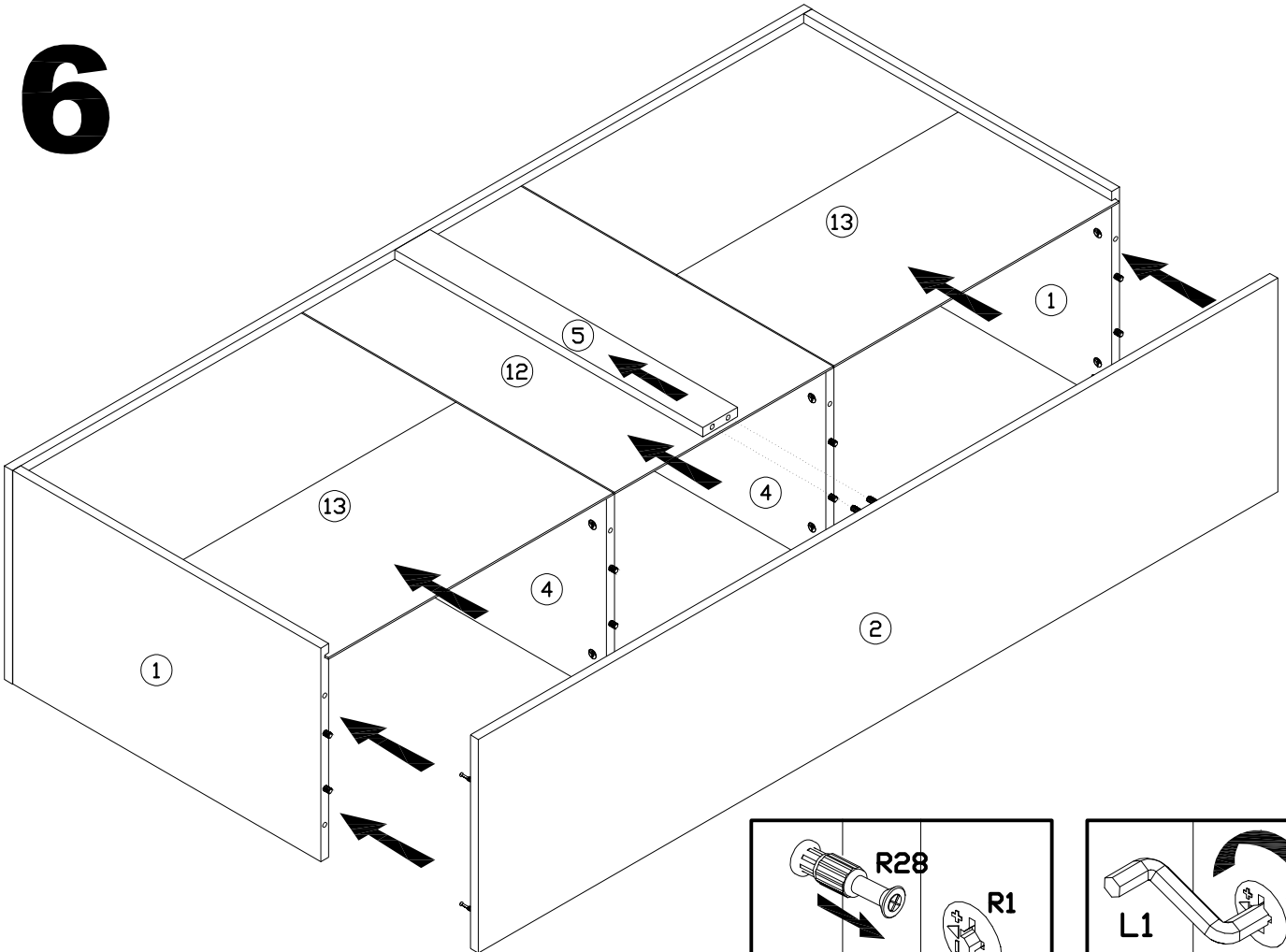

7

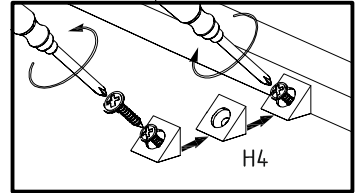
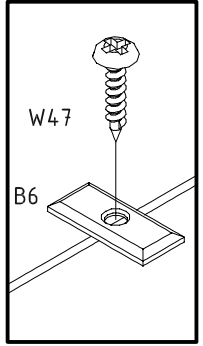
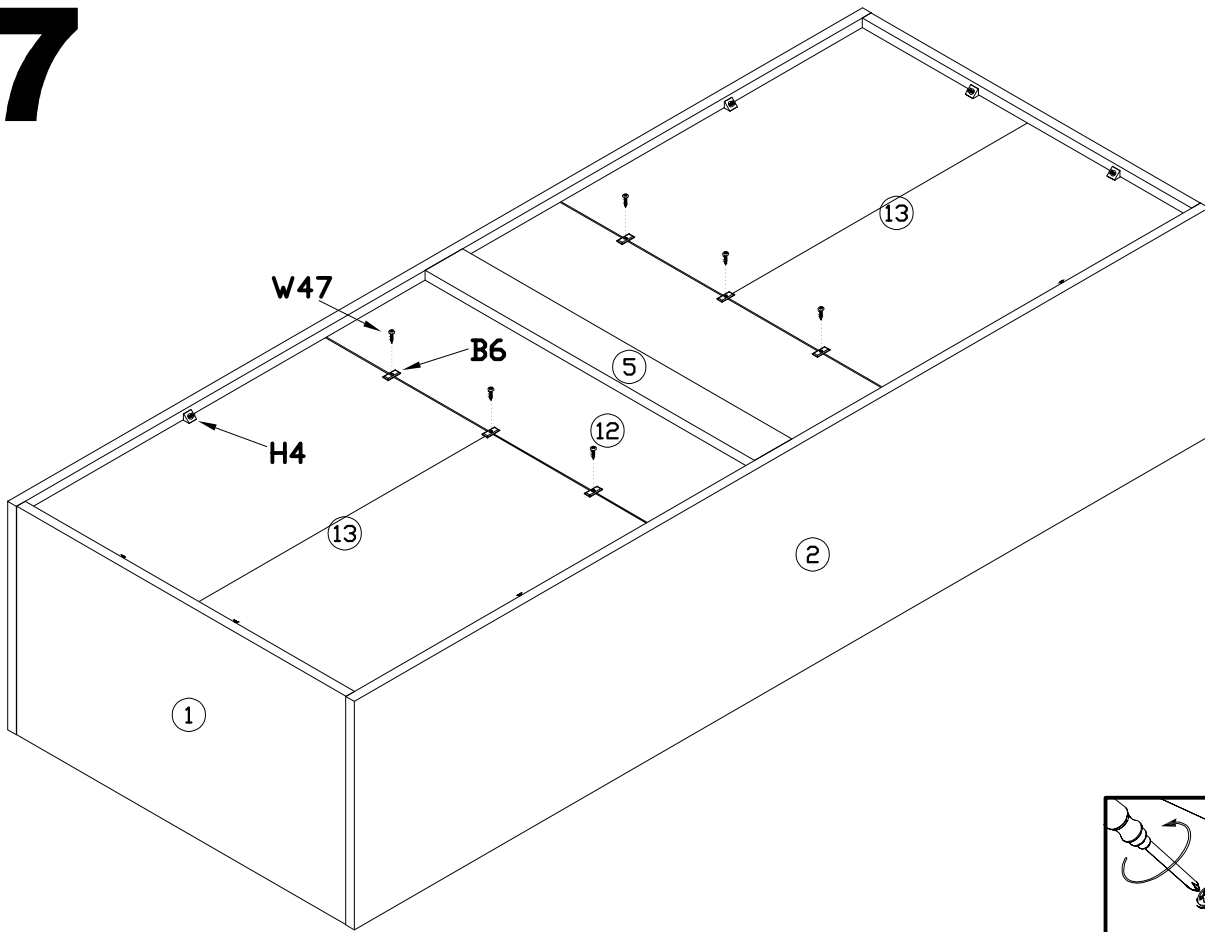

8

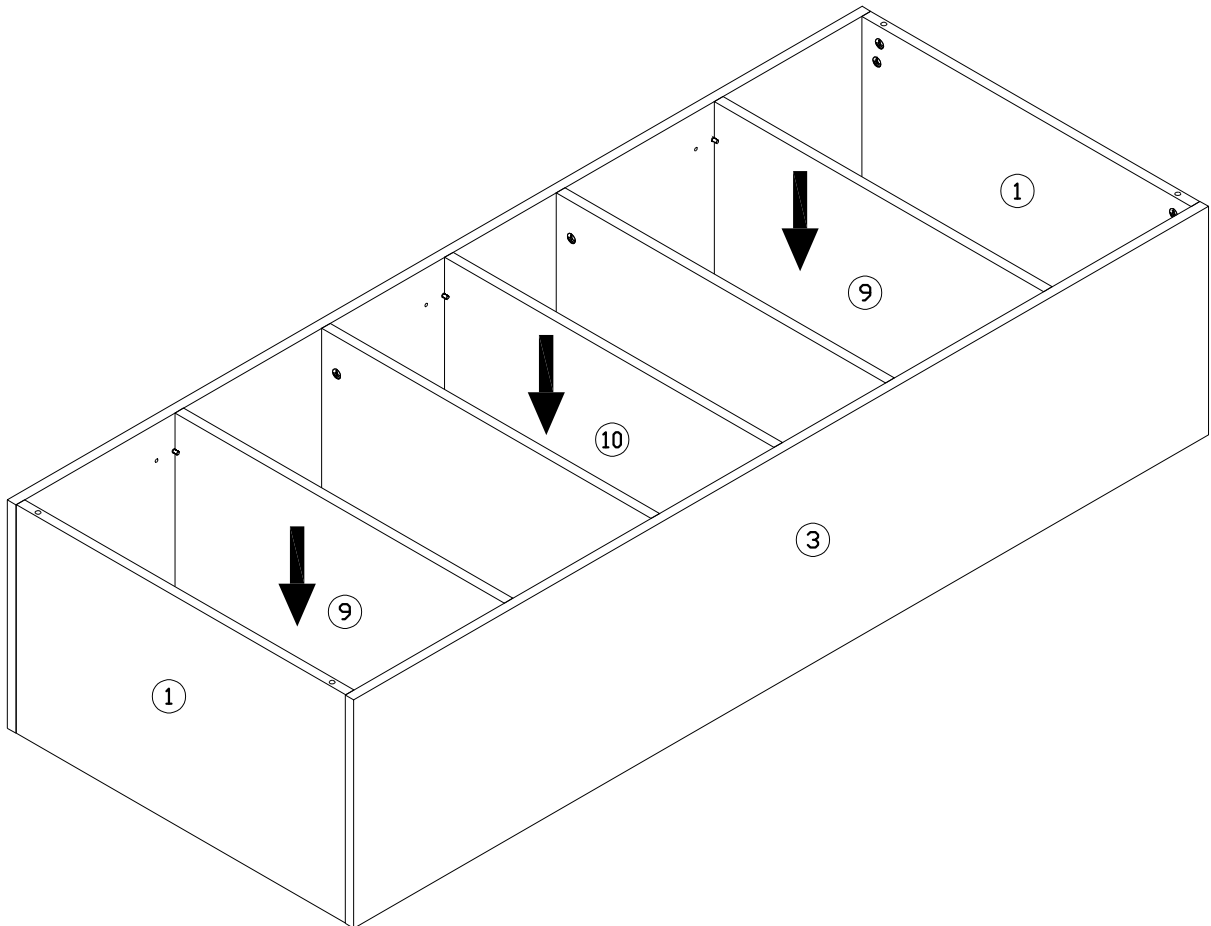

9

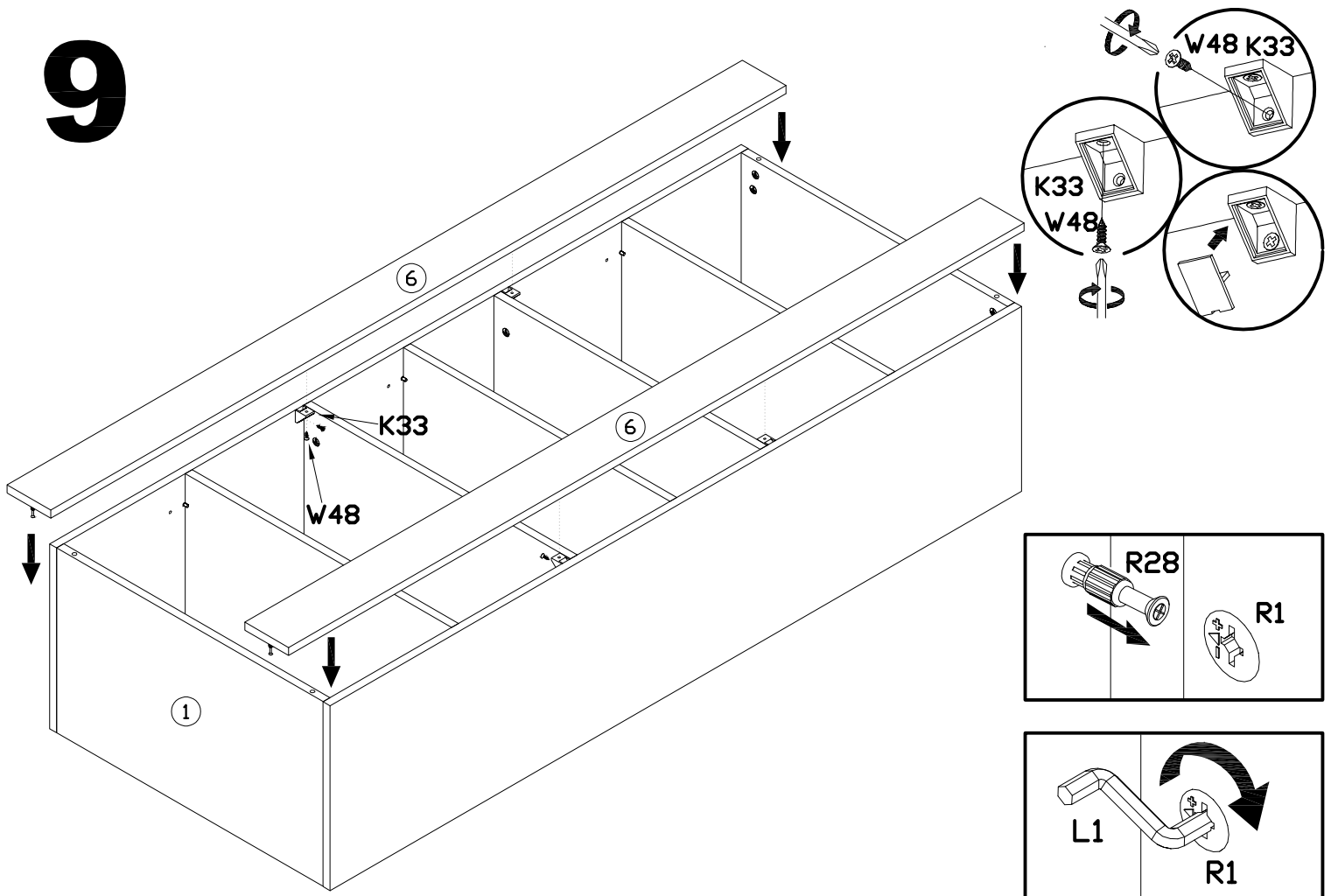

10

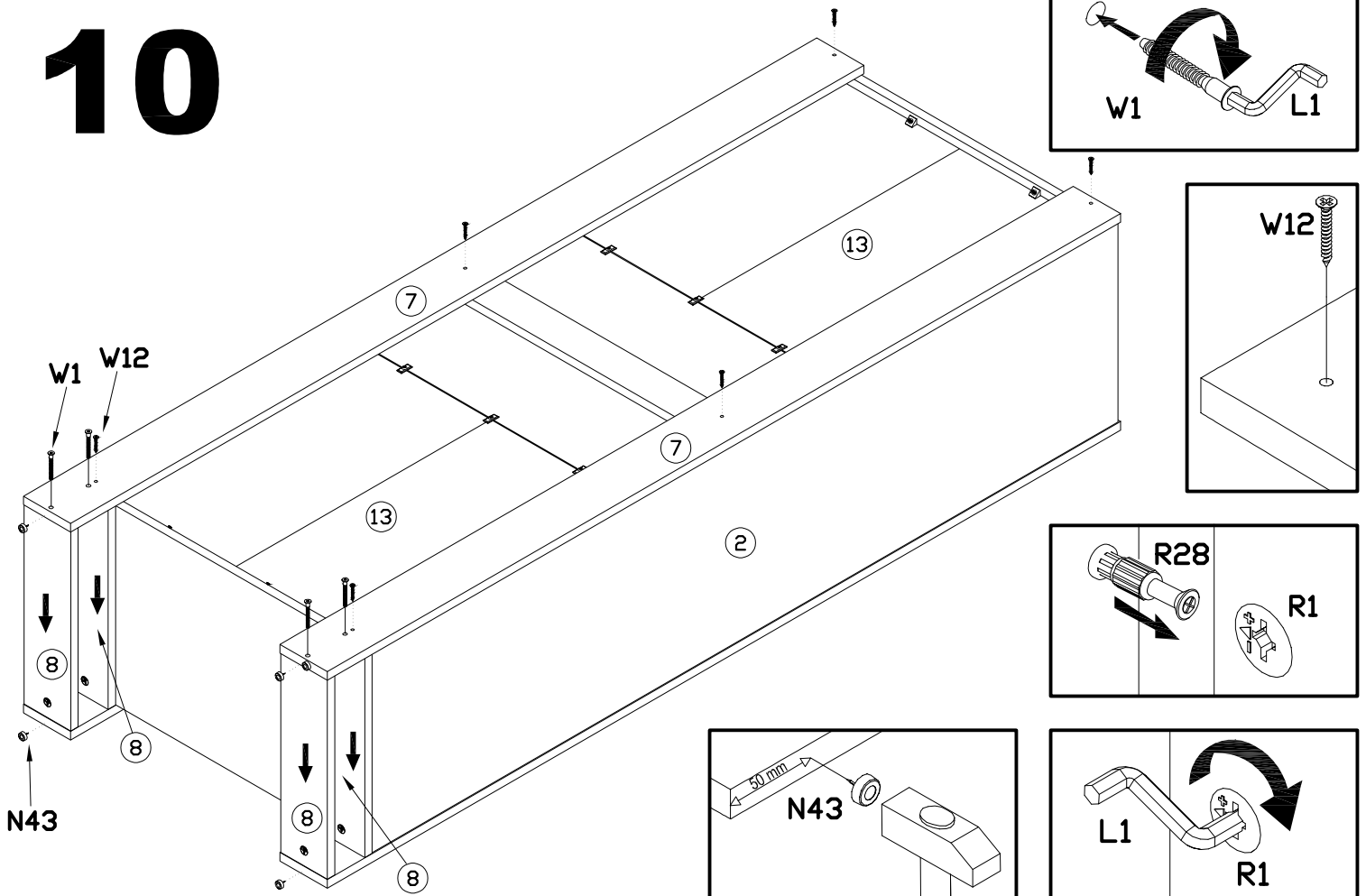

11

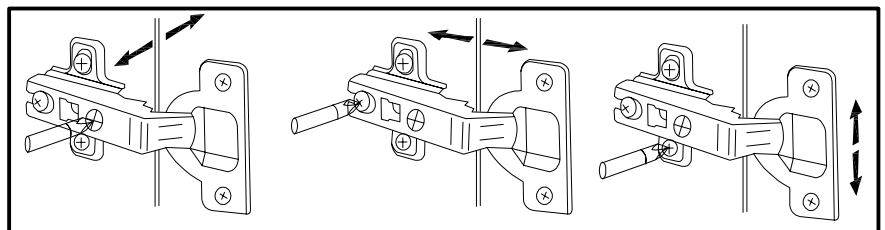
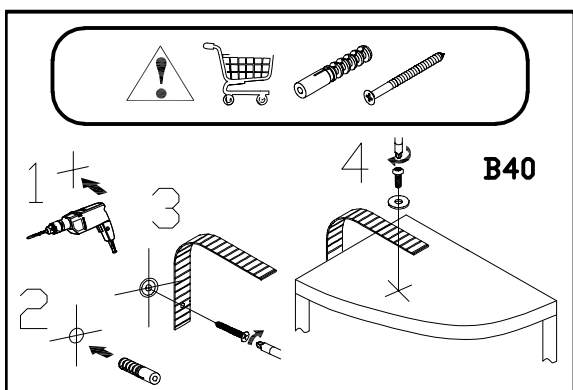
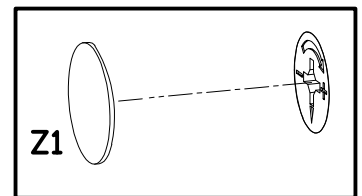
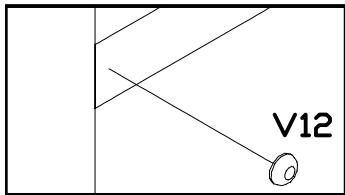
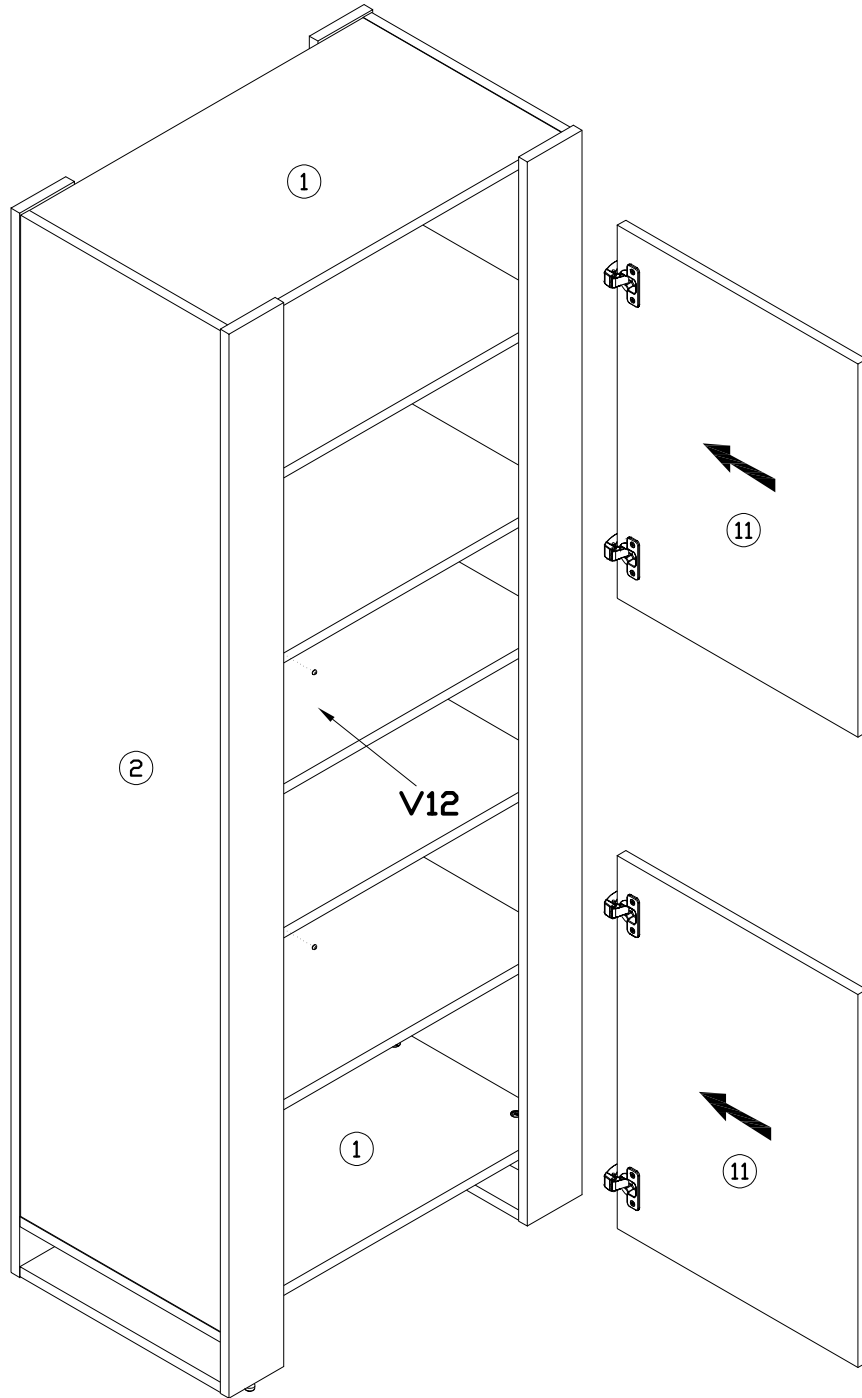
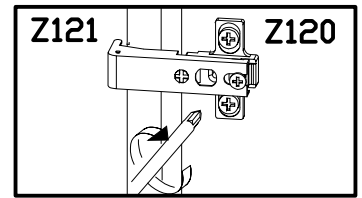
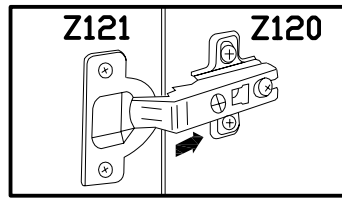
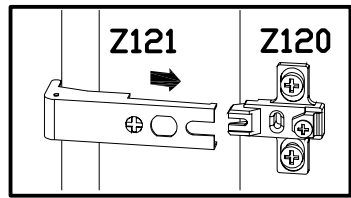

IMPORTANT SAFETY INFORMATION

ELECTRIC FIREPLACE SAFETY INFORMATION AND WARNING

ATTENTION: This Safety Information and Warning provides basic information for using an electric fireplace insert safely. Failure to follow the recommendations and warnings below may result in risk of fire, electric shock, and injury to person and property.

- **WARNING!** There's a risk of fire, electric shock, and injury to person if you don't follow the included instruction and safety information. We are not liable for any damages or injury caused by mishandling, improper installation, or improper use of the electric fireplace insert.
- **WARNING!** Prior to using your electric fireplace insert, compare the rated power of the electric fireplace insert to the capacity of the electrical circuit you plan to use it within. In order for the electric fireplace insert to be safely used, the electric fireplace insert's electrical demand, in addition to the electrical demand of any other electric devices using the circuit, should be well within the electrical capacity of the circuit. If you are unsure of the electrical capacity of the circuit, or the electrical demand of devices using the circuit, contact a licensed electrician for assistance.
- **WARNING!** Your electric fireplace insert may require a dedicated electrical circuit. Check with your local building codes.
- **WARNING!** To avoid electrical shock, do not open the back panel of the insert unless the power has been turned off and the insert has been unplugged.
- **WARNING!** The electric fireplace insert must be used on an AC supply only, and the voltage marked on the heater must correspond to the supply voltage.
- **WARNING!** Any repairs or modifications done to this electric fireplace insert are not recommended, and may cause an increased risk of fire, electric shock, and injury to person. Any repairs or modifications will void all warranty and technical support for this unit. If the decision of the user of the electric fireplace insert is to repair or modify the insert or any electrical wiring, such repairs or modifications should be done only by a licensed electrician, and must comply with local building codes.

- **WARNING!** Discontinue the use of this electric fireplace if any of the following has occurred:
 - Water damage
 - Insert has been damaged or dented
 - Power cord has become broken
 - Power cord has become too hot to touch
 - Insert smokes or smells like smoke (Note: When the heater function is used for the first time, a slight odor may be present. This is normal and should not occur again unless the heater is not used for an extended period of time.)
- **WARNING!** Do not cover or obstruct the insert in any way. The insert will overheat if covered.
- **WARNING!** Never immerse the product in water or any other liquids.
- **WARNING!** Do not run cables under carpets or rugs. Do not allow the main cables to hang over the sharp edges of the electric fireplace insert. Do not allow the main cables to come into contact with hot surfaces. From time to time, check the cable for damage. Never use the electric fireplace insert if the cable or any part of the insert shows signs of damage.
- **WARNING!** Do not switch the electric fireplace insert on until it has been properly installed as described in the instruction manual. Do not leave the electric fireplace insert unattended during use.
- **WARNING!** Keep the electric fireplace insert out of the reach of children. Do not let children operate the electric fireplace insert.
- The electric fireplace insert is fitted with a safety cut-off which will trigger if the insert overheats (e.g. due to blocked air vents). For safety reasons, the insert will NOT automatically reset. To reset the electric fireplace insert, disconnect the insert from the power supply for at least 15 minutes. After 15 minutes, reconnect the insert to the power supply and switch the insert on.

SAVE THIS SAFETY INFORMATION AND WARNING FOR FUTURE REFERENCE

**Claim your extended 90 day product warranty
by registering your product at
www.meblefurniture.com/register**

**ATTENTION: DO NOT RETURN THIS PRODUCT!!!
PLEASE READ THE FOLLOWING!!!**

FOR REPLACEMENT/MISSING PARTS:

www.meblefurniture.com/parts

**FOR INSTRUCTION/ASSEMBLY MANUALS
AND VIDEOS:**

www.meblefurniture.com/assembly

ALL OTHER INQUIRIES:

help@meblefurniture.com

**IF YOU ARE MISSING PARTS OR YOUR
PRODUCT ARRIVED DAMAGED:**

Please fill out a parts request form at
www.meblefurniture.com/parts

Replacement parts are shipped out in one business day. You will receive a tracking number via email once your parts request has been processed.

**IF YOU ARE MISSING AN INSTRUCTION
MANUAL OR NEED ASSEMBLY HELP:**

Please visit www.meblefurniture.com/assembly to access our library of product assembly videos or to download product instruction manuals.

**NOTICE REGARDING HIGH GLOSS
PROTECTIVE FOIL AND PRODUCT CARE:**

After removing the protective foil from the gloss fronts, the acrylic surface of the boards is still soft and easy to scratch. With air contact, the hygroscopic acrylic layer hardens, and the board becomes more resistant to scratches. It takes approximately 48 hours for the acrylic layer of the board to fully harden.

**DO NOT CLEAN, WIPE, OR POLISH THE
ACRYLIC FRONTS FOR 48 HOURS AFTER
REMOVING THE PROTECTIVE FOIL!!!**



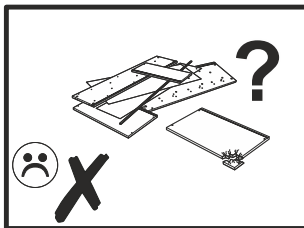
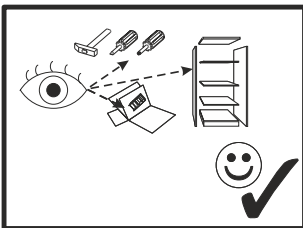

D: ALLGEMEINE HINWEISE FÜR MÖBEL AUS HOLZ UND HOLZWERKSTOFFE: MELAMIN, LAMINAT, ARMATURENBRETT
Zu reinigen, verwenden Sie ein feuchtes Tuch. Verwenden Sie nur Wasser oder ein mildes Reinigungsmittel. Wischen Sie mit einem Tuch trocken.

GB: GENERAL INSTRUCTIONS FOR FURNITURE OF WOOD AND WOOD MATERIALS: MELAMINE, LAMINATE, DASHBOARD
To clean, use a damp cloth. Use only water or a mild detergent. Wipe dry with a cloth.

ES: INSTRUCCIONES GENERALES PARA MUEBLES DE MADERA Y MATERIALES: MELAMINA, LAMINADO, TABLERO DE INSTRUMENTOS
Para limpiar, utilice un paño húmedo. Utilice sólo agua o un detergente suave. Seque con un paño

FR: INSTRUCTIONS GENERALES DE MEUBLES DE MATÉRIAUX DE BOIS ET: MÉLAMINÉS, STRATIFIÉS, TABLEAU DE BORD
Pour nettoyer, utilisez un chiffon humide. d'eau ou d'un détergent doux. Essuyer avec un chiffon.

CZ: VŠEOBECNÉ POKYNY PRO NÁBYTEK ZE DŘEVA A DŘEVĚNÝCH MATERIÁLŮ: MELAMINE, LAMINÁT, DASHBOARD
K čištění použijte vlhký hadřík. Používejte pouze vodu nebo jemným čistícím prostředkem. Vytřete do sucha hadříkem.

PL: OGÓLNE INSTRUKCJE DOTYCZĄCE MEBLI Z DREWNA ORAZ MATERIAŁÓW DREWNOPOCHODNYCH: MELAMINA, LAMINAT, OKLEINA
Do czyszczenia należy używać wilgotnej ściereczki. używać wyłącznie wody lub delikatnego detergentu. Wycierać do sucha ściereczką.

HU: A BÚTOR ÁLTALÁNOS FAANYAGOK ÉS FAIPARI ANYAGOK: MELAMIN, LAMINÁT, MÚSZERFAL
A tisztításhoz használjon egy nedves ruhával. Csak vizet vagy enyhe tisztítószerrel. Töröld szárazra egy ronggyal.

HU: A BÚTOR ÁLTALÁNOS FAANYAGOK ÉS FAIPARI ANYAGOK: MELAMIN, LAMINÁT, MÚSZERFAL
A tisztításhoz használjon egy nedves ruhával. Csak vizet vagy enyhe tisztítószerrel. Töröld szárazra egy ronggyal.

SK: VŠEOBECNÉ POKYNY PRO NÁBYTEK ZE DŘEVA A DŘEVĚNÝCH MATERIÁLŮ: MELAMINE, LAMINÁT, DASHBOARD
Na čistenie použite vlhkú handričku. používajte iba vodu alebo jemným čistiacim prostriedkom. Vytrite dosucha handričkou.

RU: ОБЩИЕ ПРАВИЛА ДЛЯ МЕБЕЛИ ДРЕВЕСИНЫ И ДРЕВЕСНЫХ МАТЕРИАЛОВ: МЕЛАМИН, ЛАМИНАТ, ПАНЕЛЬ
Для очистки используйте влажную ткань. Используйте только воду или мягкое моющее средство. Протрите сухой тряпкой.

IT: ISTRUZIONI GENERALI PER MOBILI DI LEGNO E LEGNO MATERIALI: MELAMINICO, LAMINATO, CRUSCOTTO
Per la pulizia, utilizzare un panno umido. Utilizzare solo acqua o un detergente neutro. Asciugare con un panno.

RO: INSTRUCȚIUNI GENERALE DE MOBILIER DE LEMNOASA ?I MATERIALE LEMNOASE: PAL, LAMINAT, TABLOU DE BORD
Pentru a cură?a, folosi?i o carpa umeda. Folosi?i numai apa sau un detergent slab. Sterge cu o carpa.

TR: AHŞAP VE AHŞAP MALZEMELERIN MOBILYA İÇİN GENEL BİLGİLER: MELAMIN, LAMINAT, PANEL
Temizlemek için, nemli bir bez kullanın. Sadece su veya hafif bir deterjan kullanın. Bir bez ile kurulayın.

NL: ALGEMENE RICHTLIJNEN VOOR MEUBELEN VAN HOUT EN HOUTPRODUCTEN MATERIALEN: MELAMINE, LAMINAAT, DASHBOARD
Schoon te maken, gebruikt u een vochtige doek. Gebruik alleen water of een mild schoonmaakmiddel. Veeg met een doek droog.

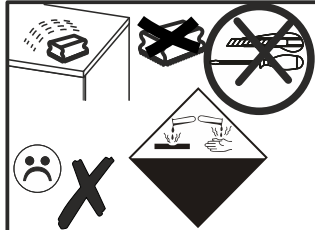
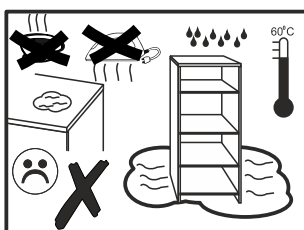
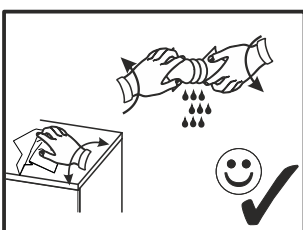
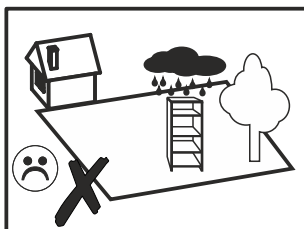
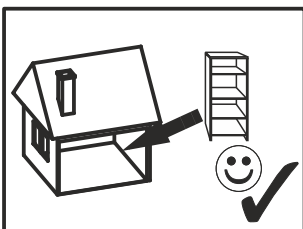
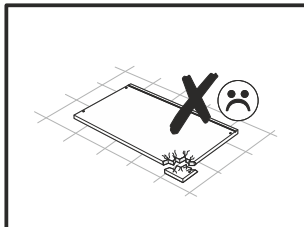
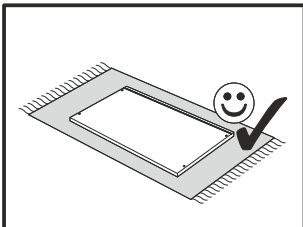
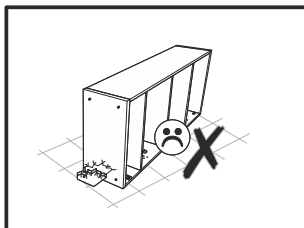
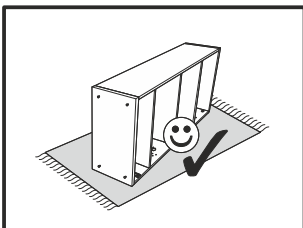
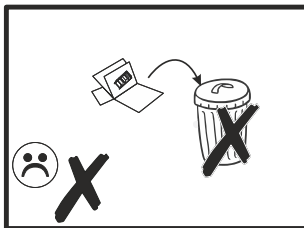
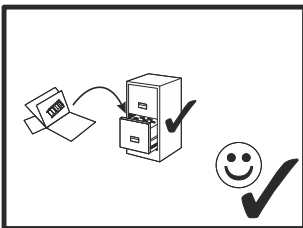

PL: Komplementowanie akcesorii oraz proces pakowania odbywa się pod nadzorem kontroli jakości oraz monitoringu.

EN: Complementing the accessories and the packaging process is carried out under the supervision of quality control and monitoring.

DE: Die Ergänzung des Zubehörs und des Verpackungsprozesses erfolgt unter der Aufsicht der Qualitätskontrolle und -überwachung.

FR: Le complément des accessoires et du processus d'emballage s'effectue sous la supervision d'un contrôle et d'une surveillance de la qualité.