

Do montażu potrzebne są:
 Für die Montage dieser Type benötigen Sie:
 Use the following for assembly:

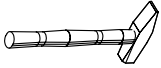

D Sehr geehrter Kunde, sollte ein Teil fehlen oder beschädigt sein, kreuzen Sie bitte dieses deutlich auf der Montageanleitung an und schicken Sie zu uns ab.
 GB Dear customer, Should there be any place missing or damaged, kindly mark this place clearly on the attached assembly instructions and return it to us.
 PL Szanowny Kliencie, gdyby brakowało jakiegokolwiek części lub byłaby uszkodzona proszę to oznaczyć krzyżykiem na instrukcji montażowej i przesłać instrukcję razem z reklamacją.

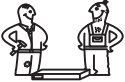
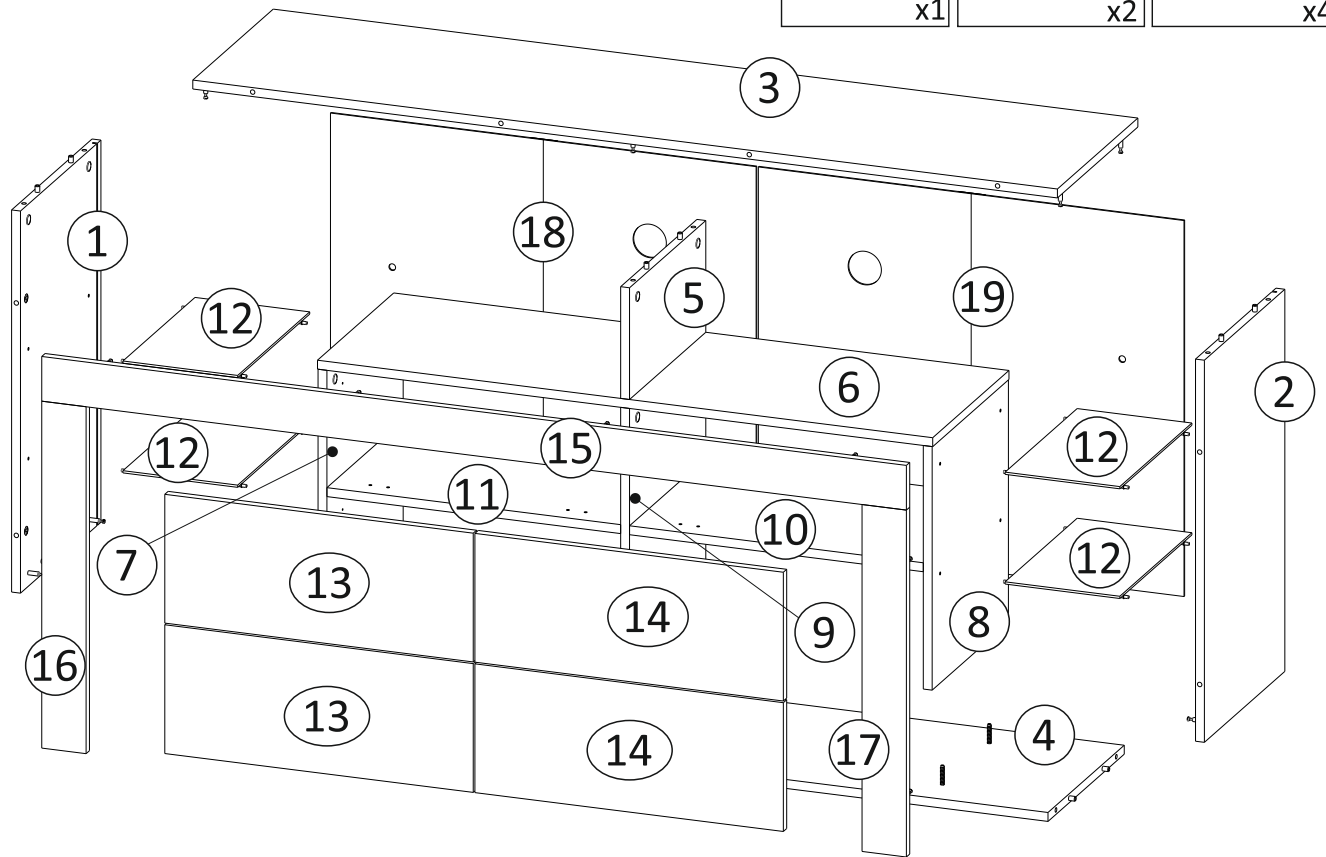
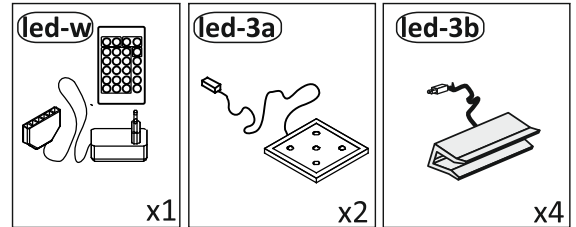

BAG 1

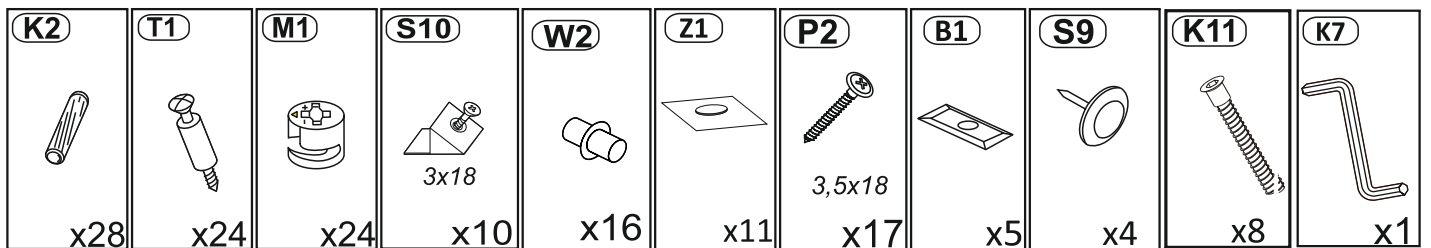

BAG 2

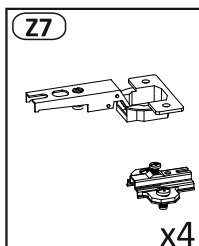

S3

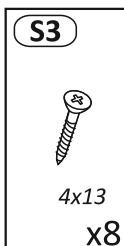

BAG 3

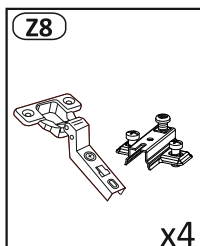

S3



BAG 4

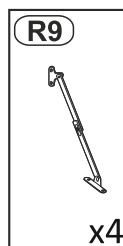

S1

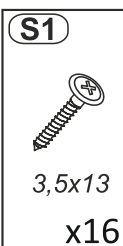

BAG 5

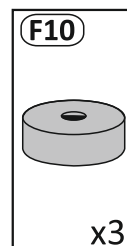

P14

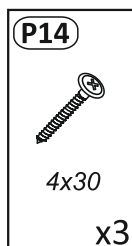

1

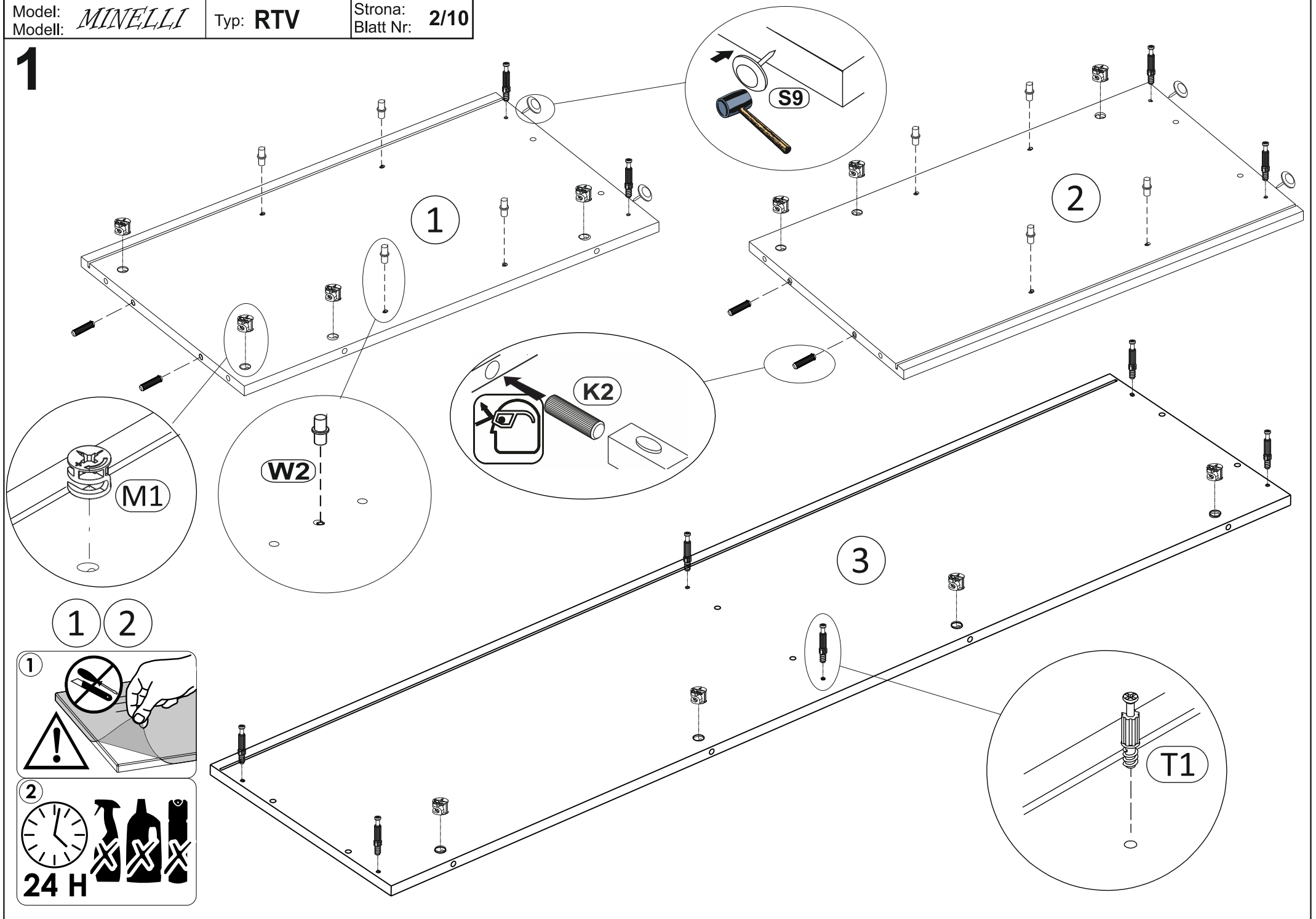

1 2

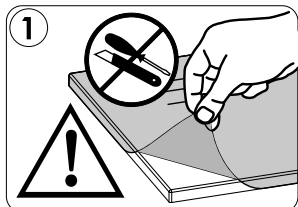

24 H

2

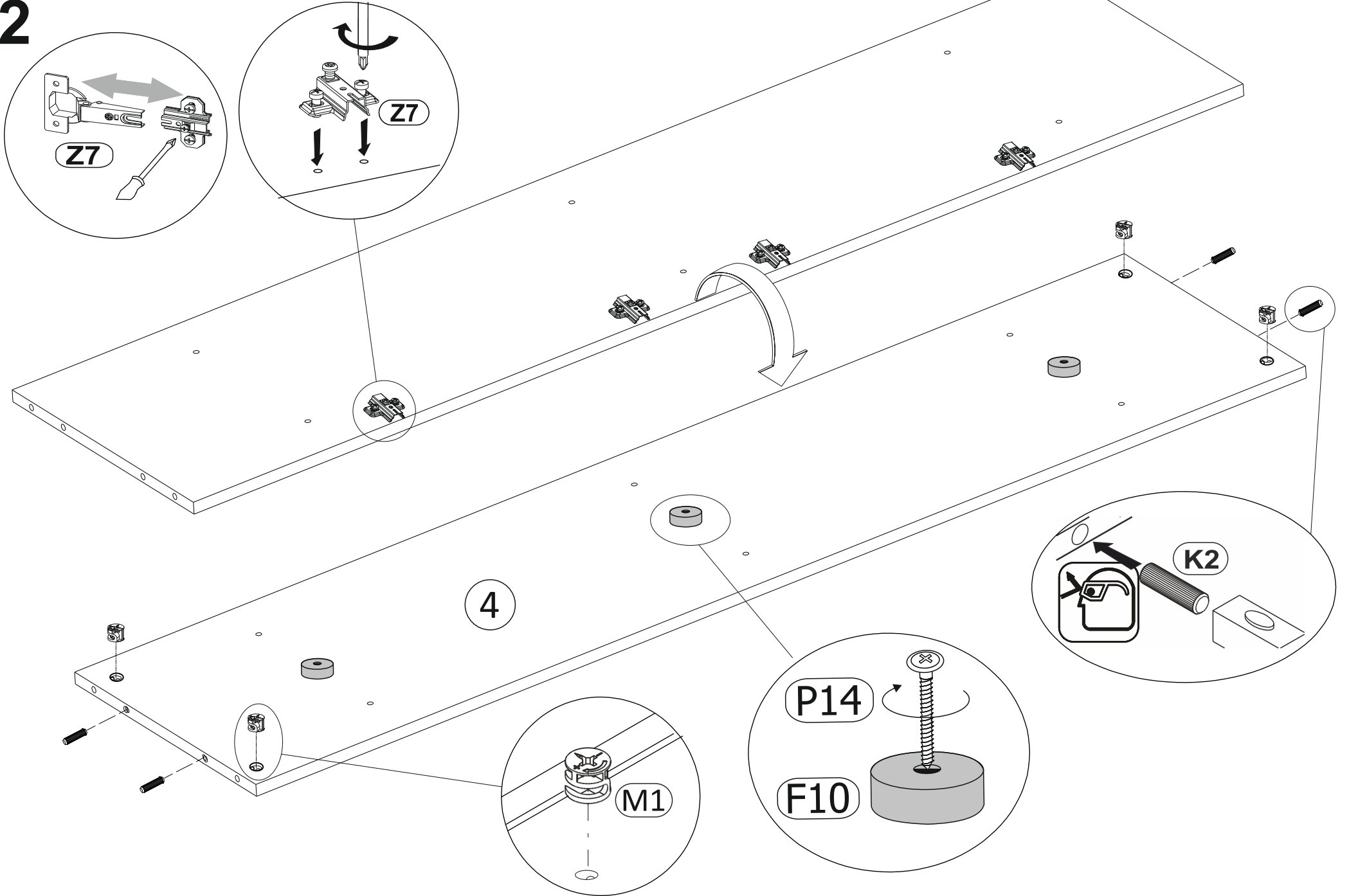

3

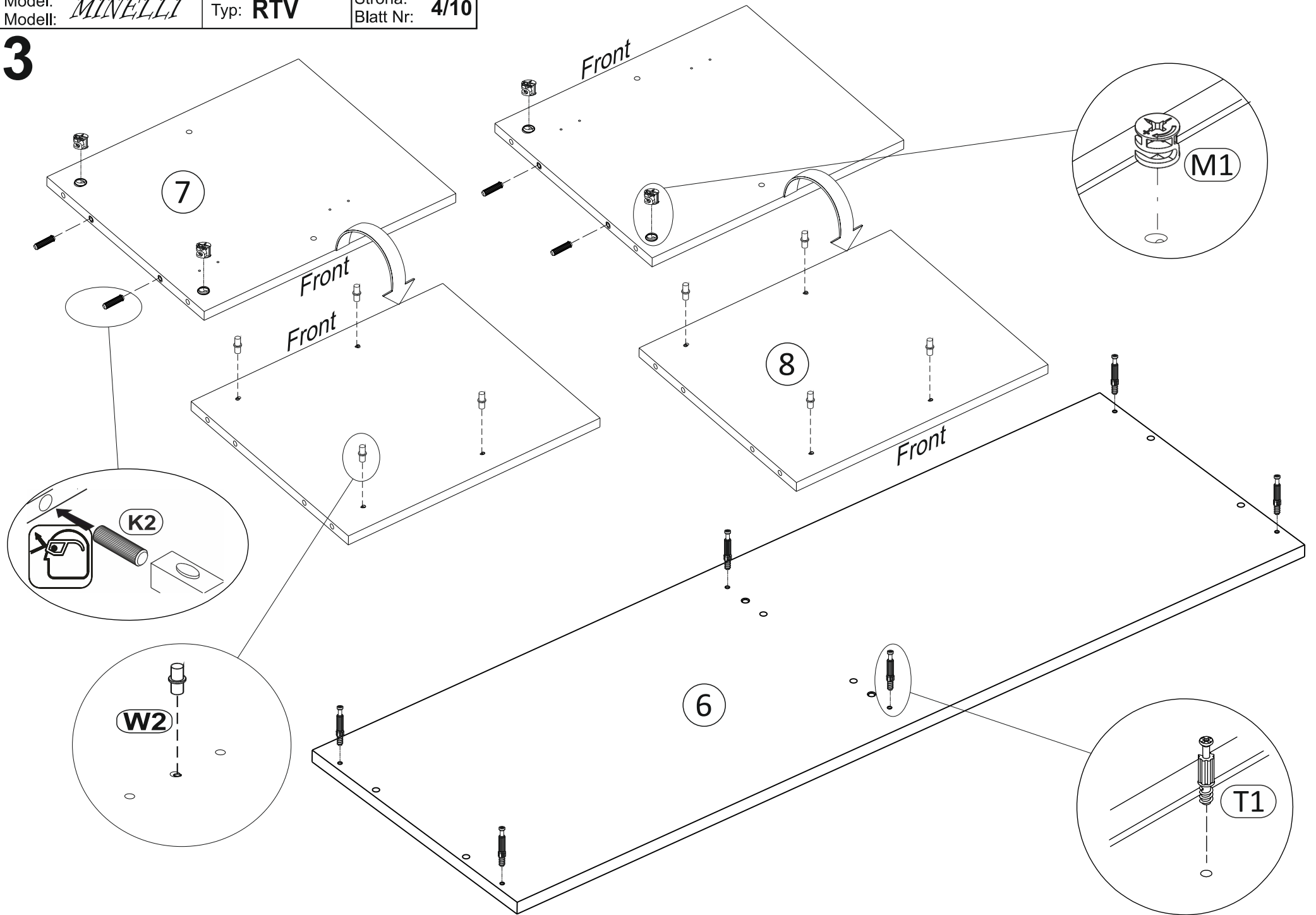

4

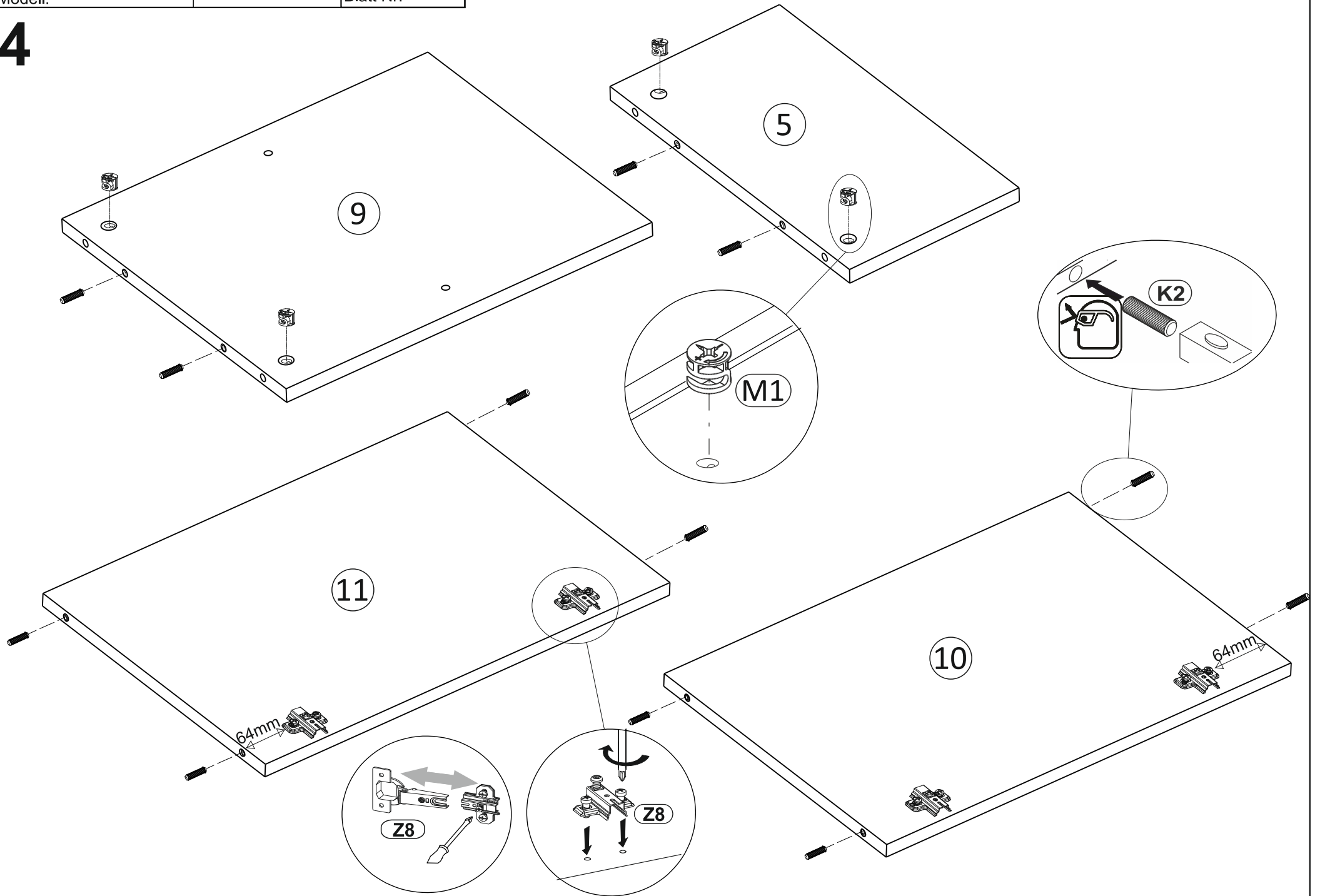

5

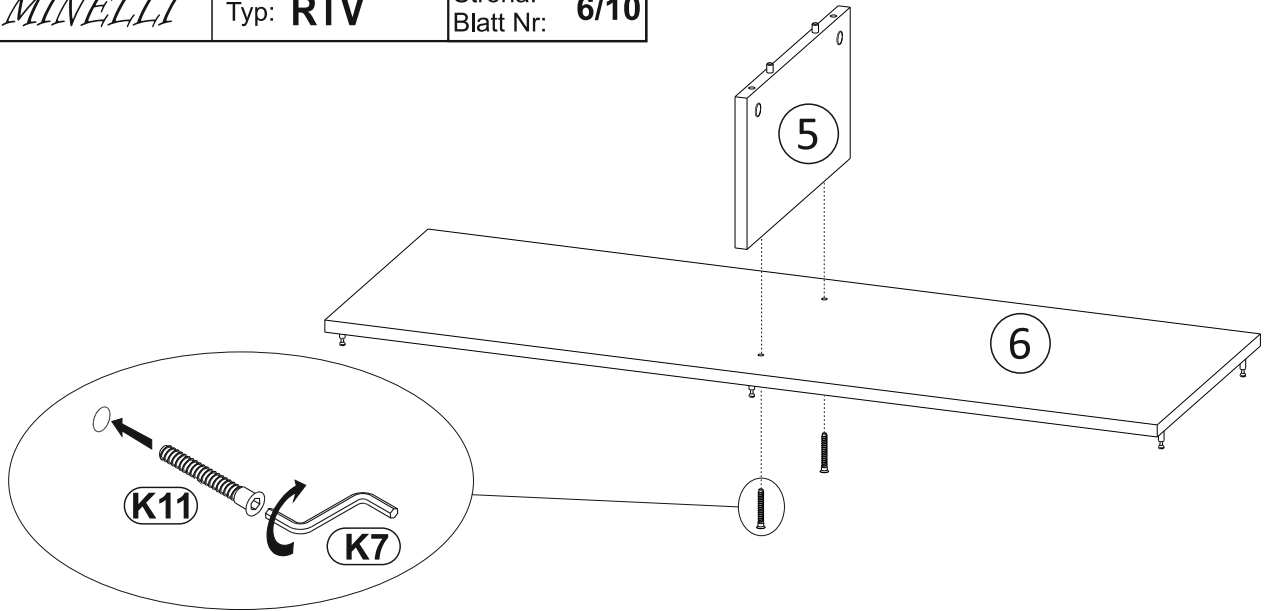

6

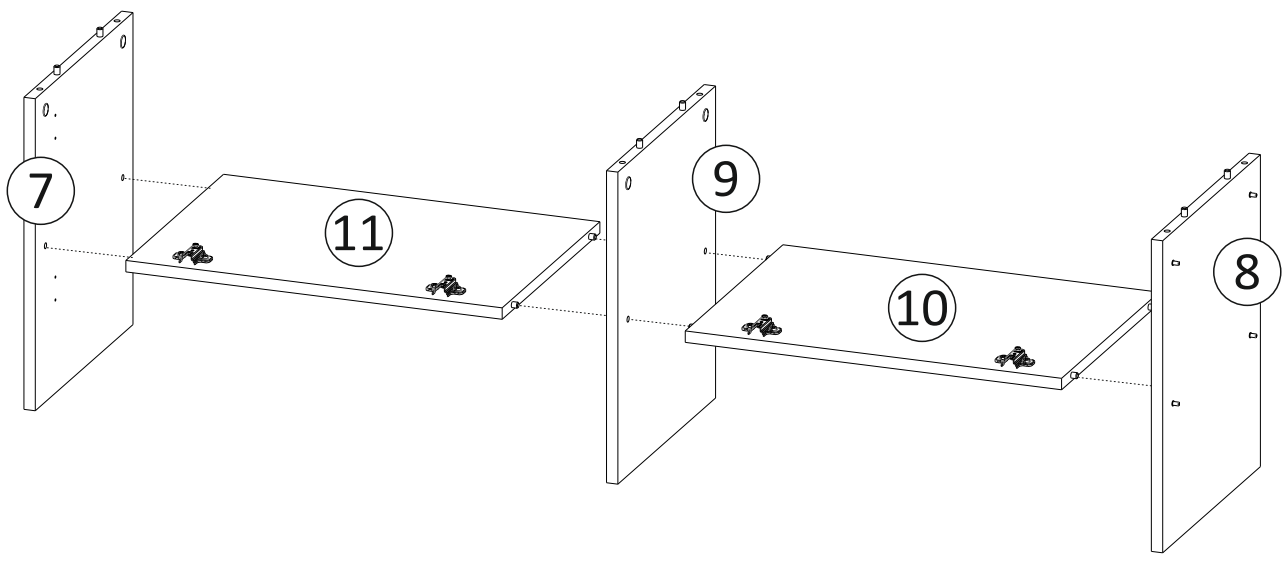

7

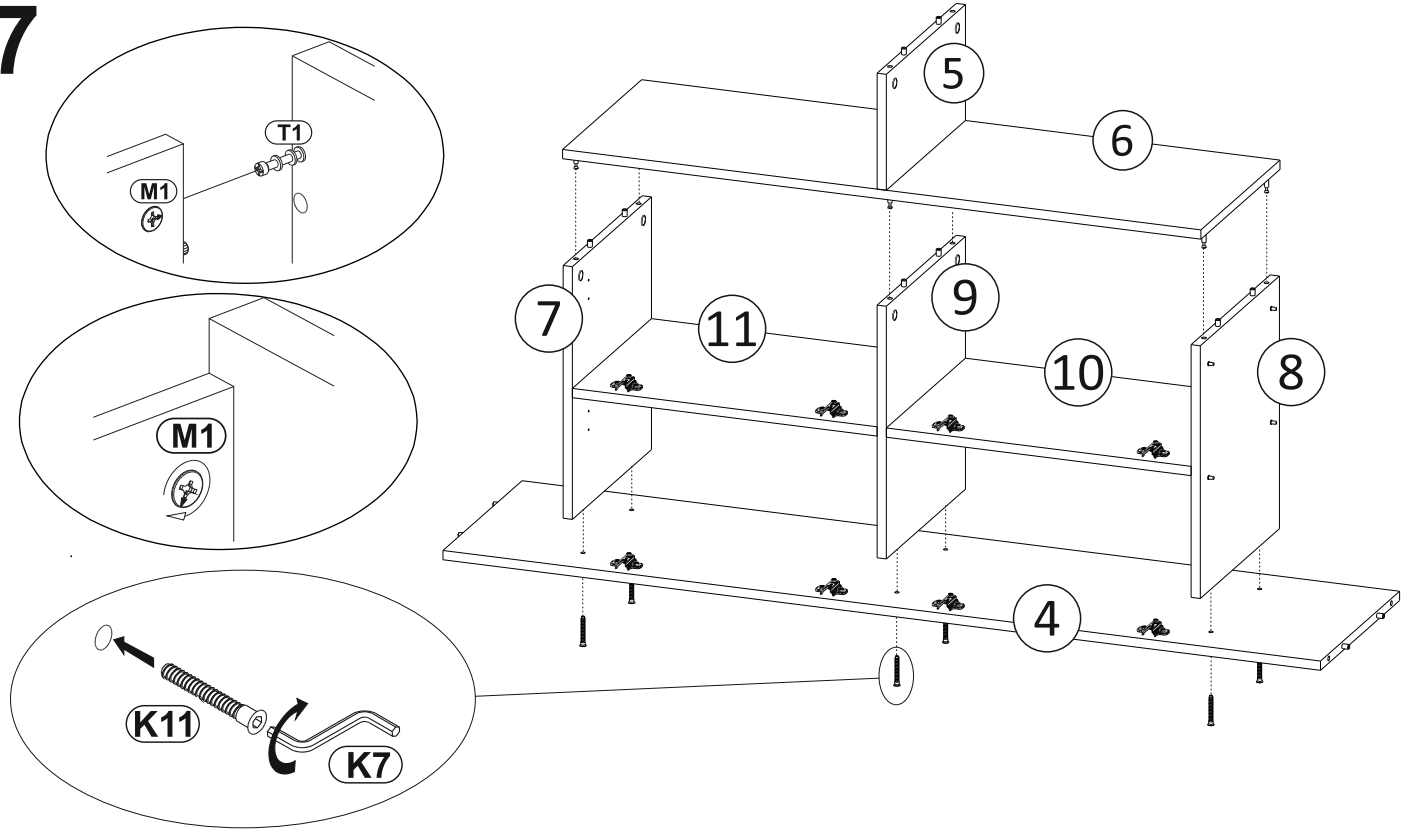

8

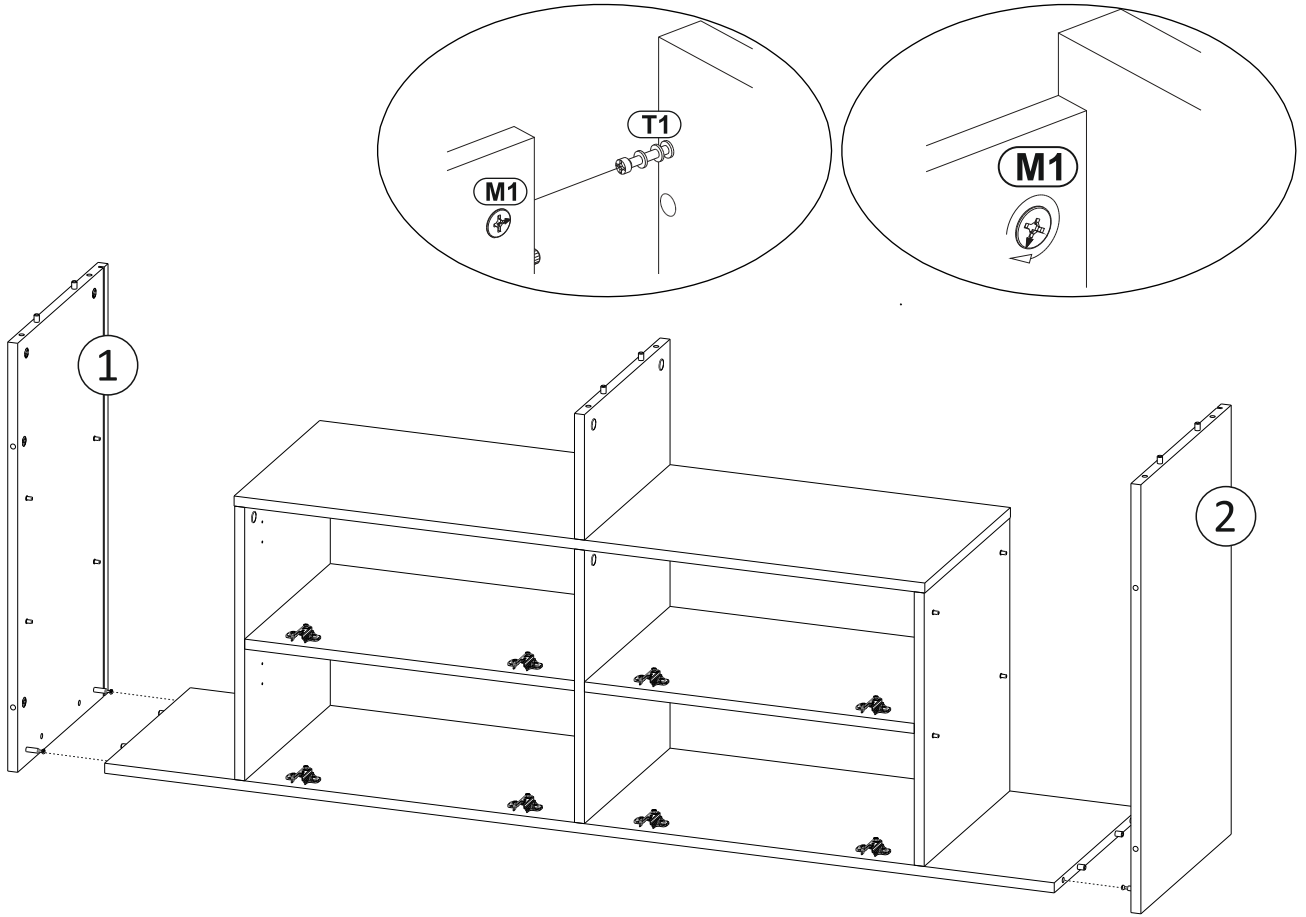

9

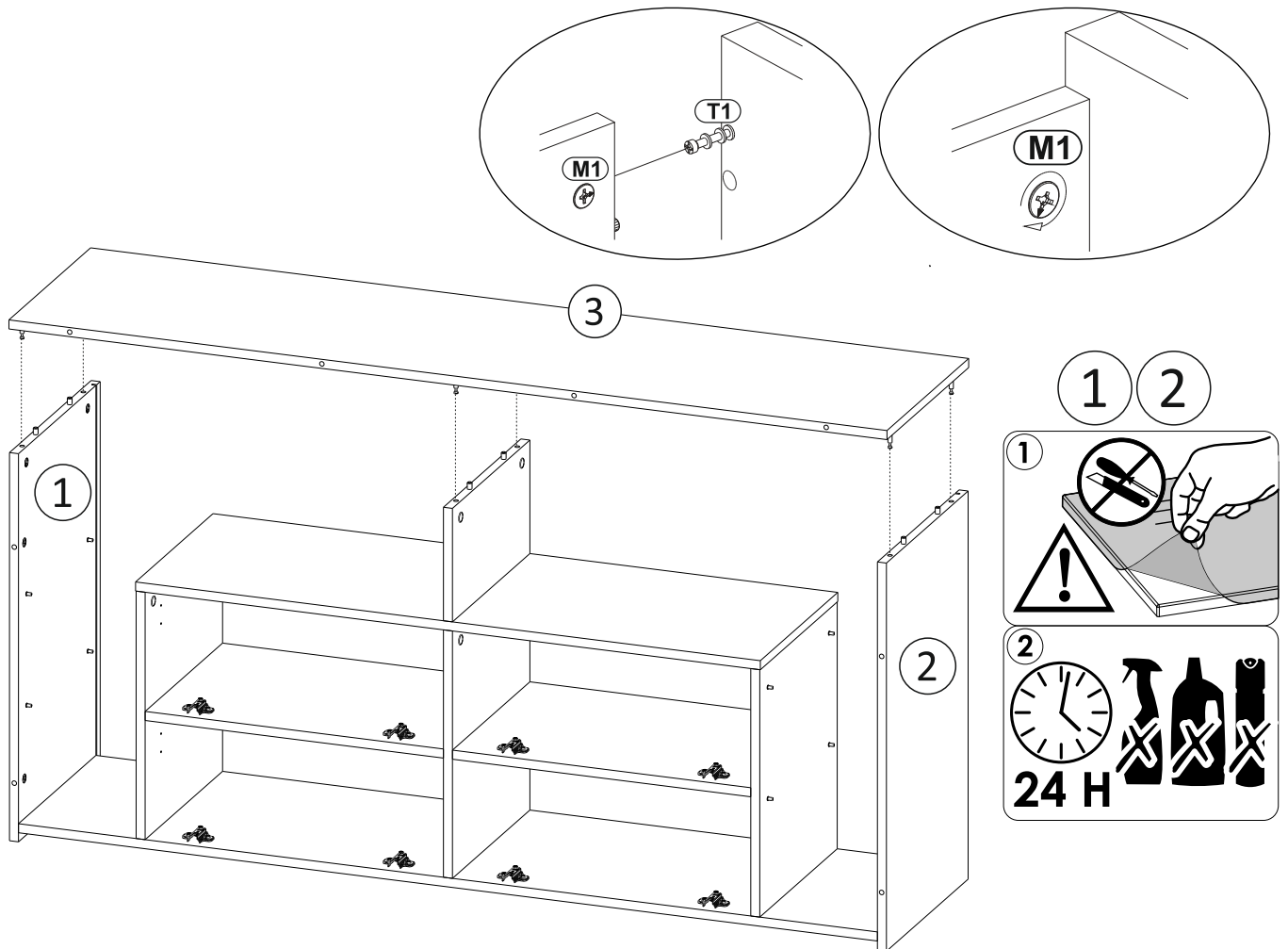

10

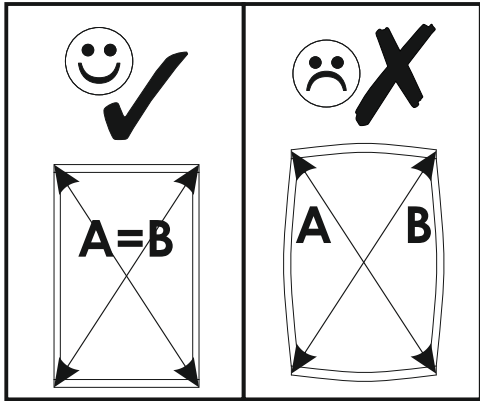
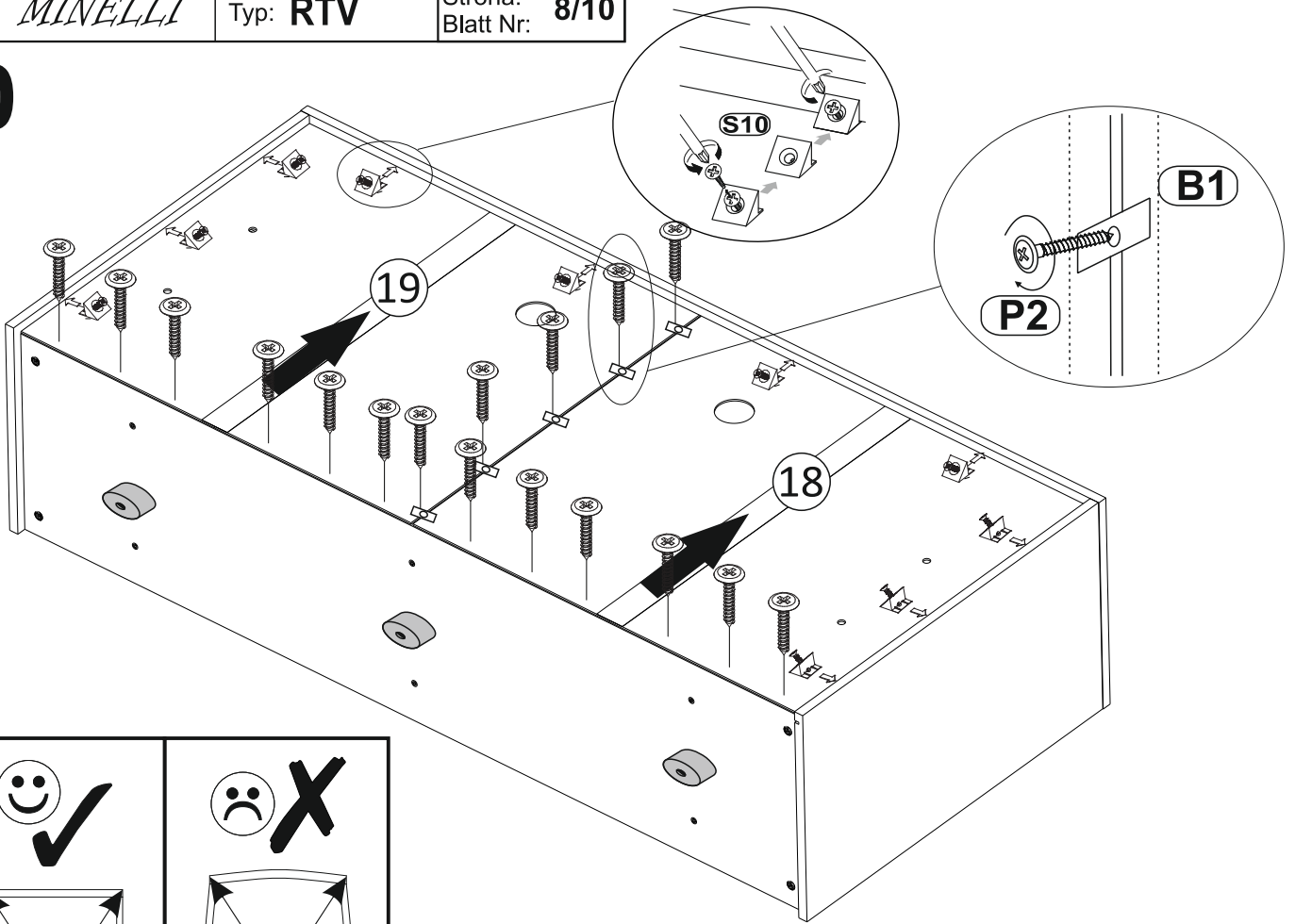

11

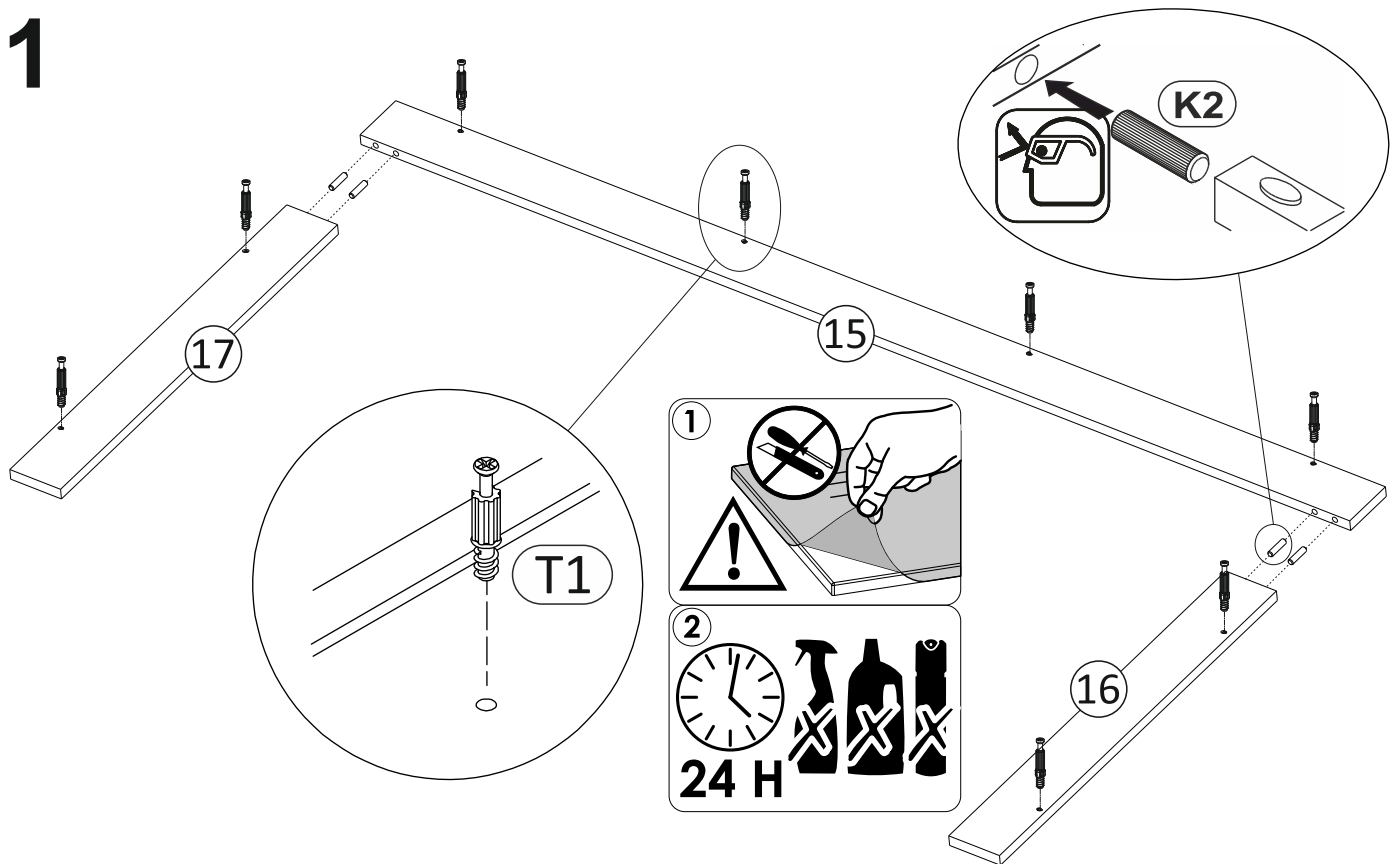

12

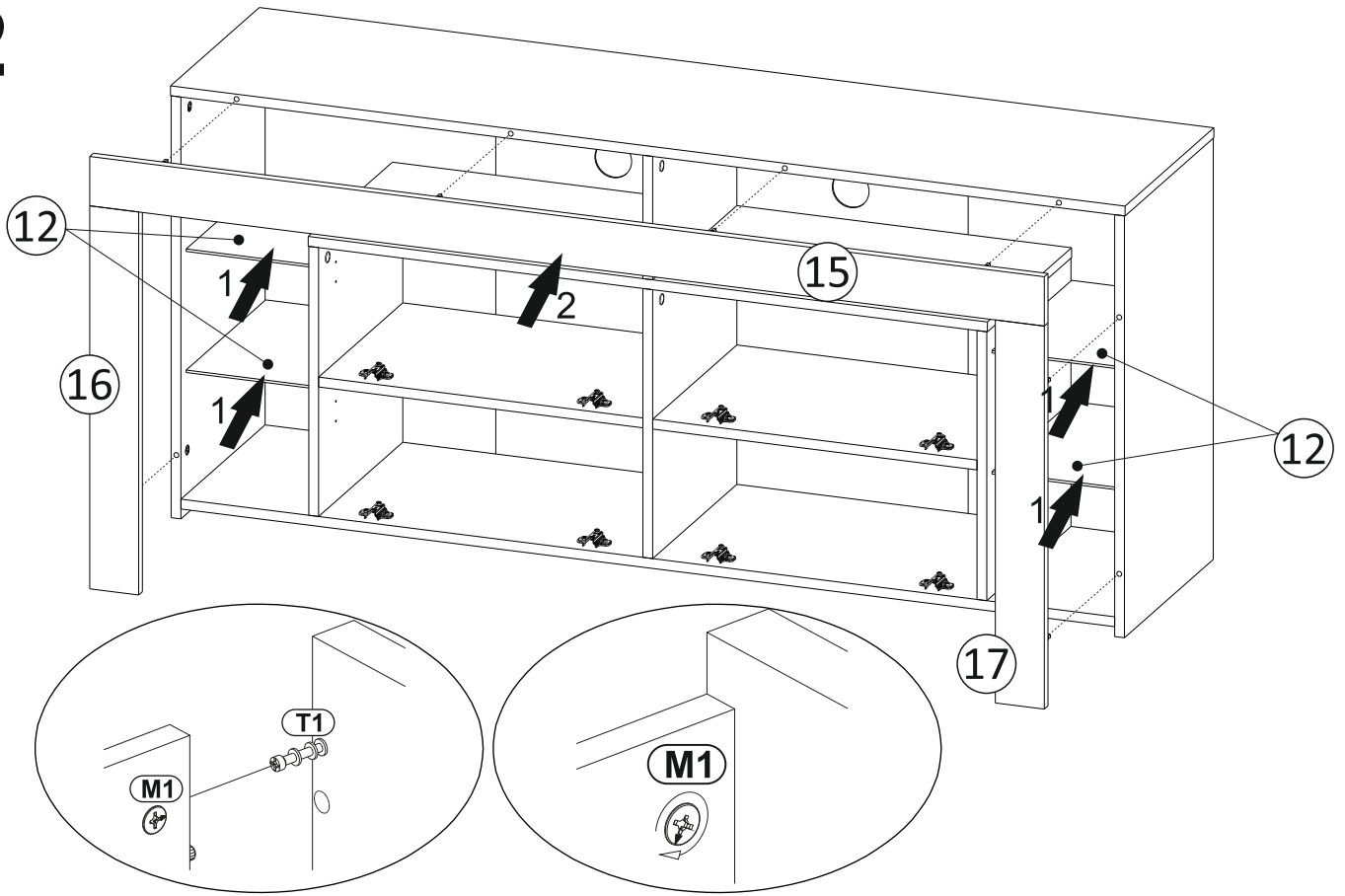

13

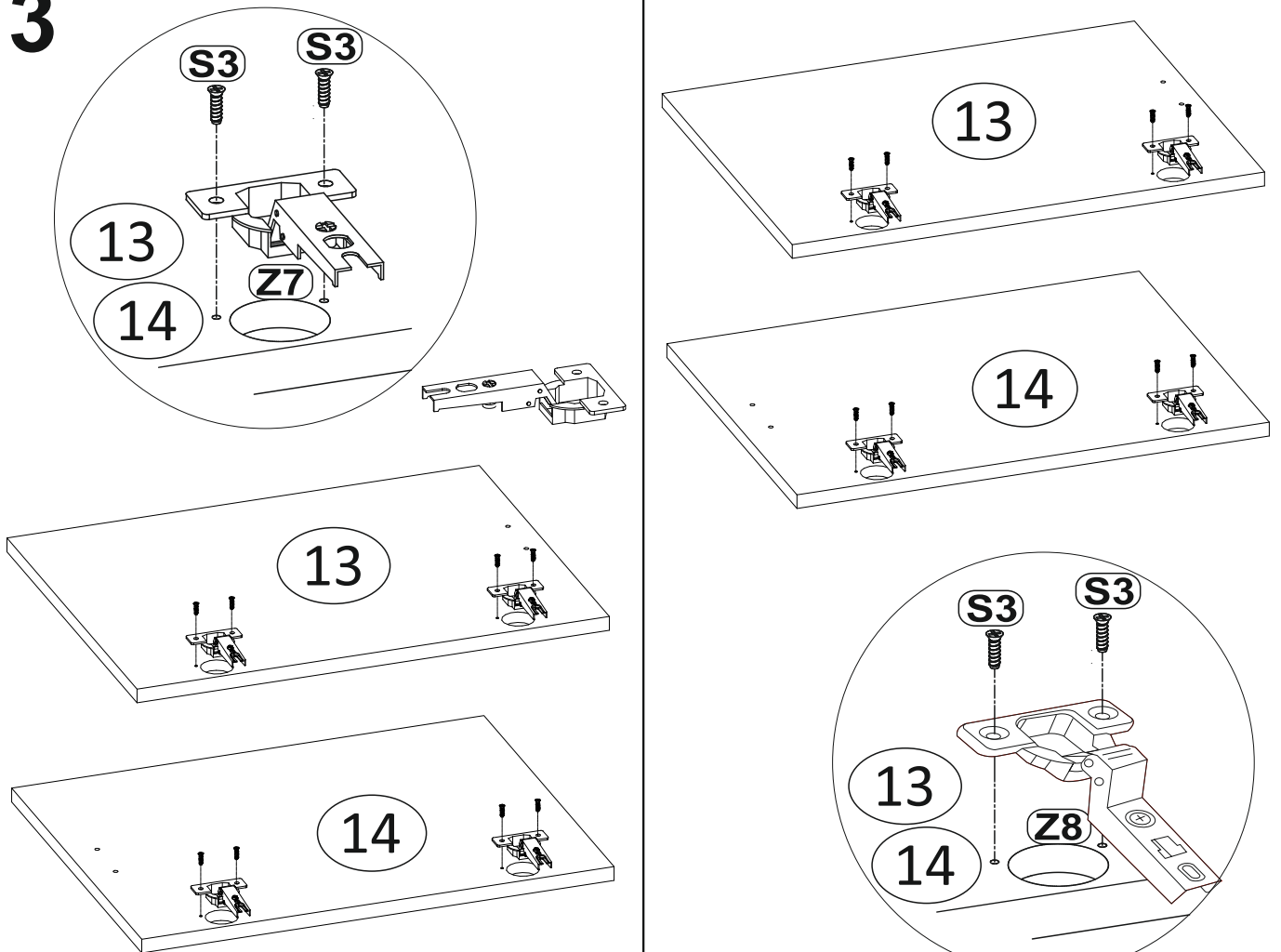

14

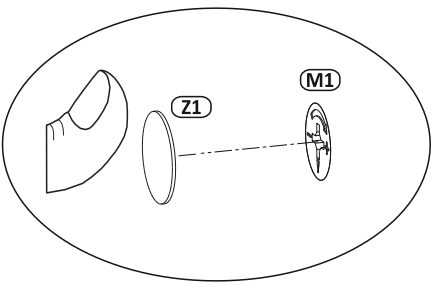
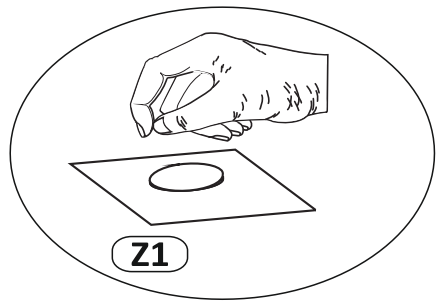
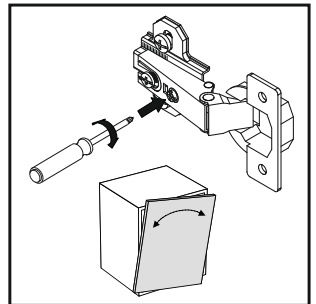
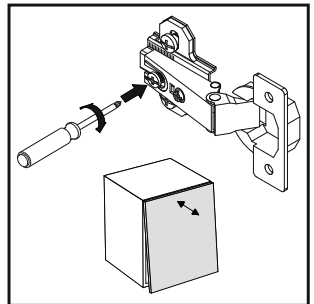
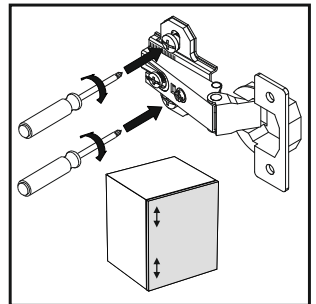
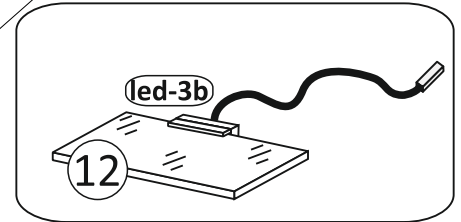
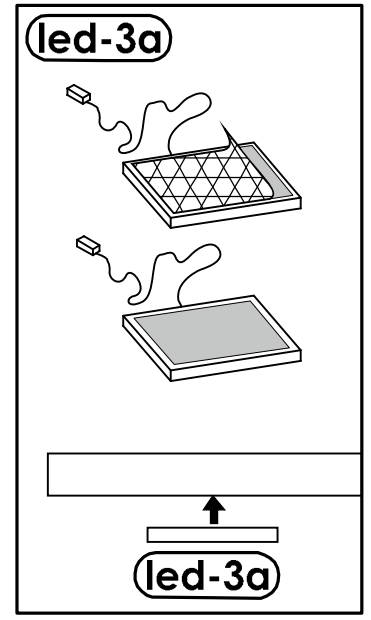
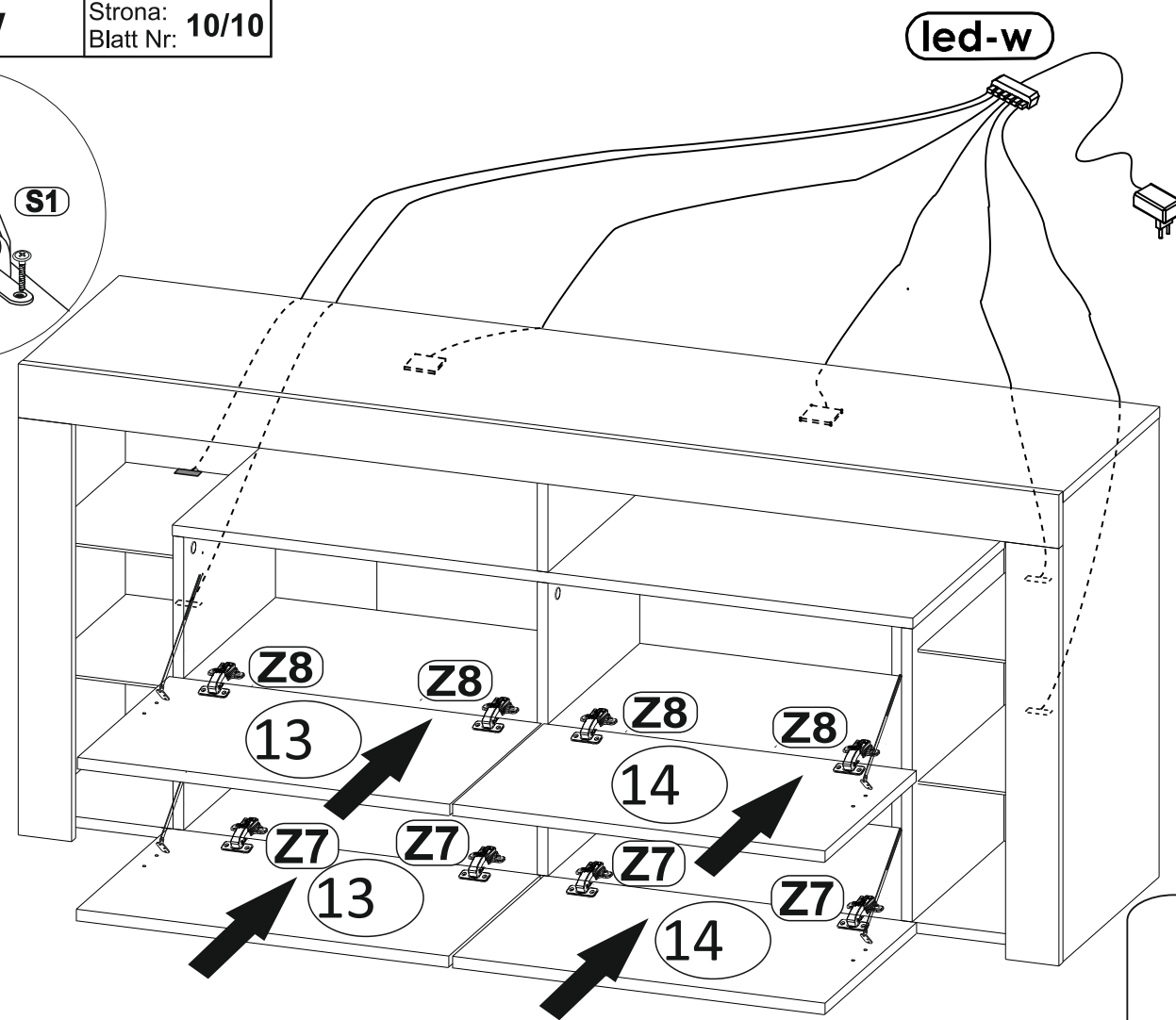
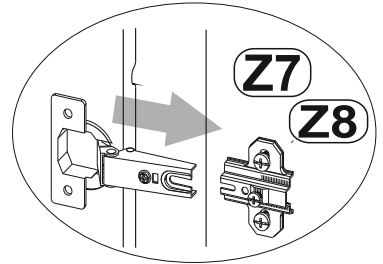
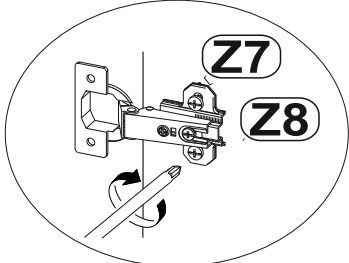
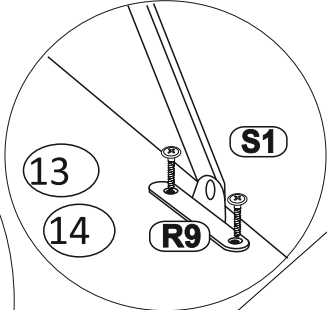
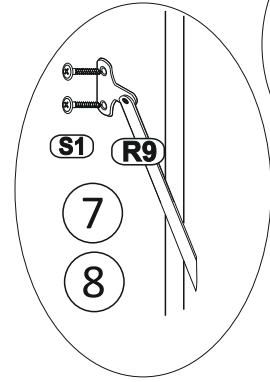



www.meblefurniture.com
help@meblefurniture.com
866-777-5105

**Claim your extended 90 day product warranty
by registering your product at
www.meblefurniture.com/register**

**ATTENTION: DO NOT RETURN THIS PRODUCT!!!
PLEASE READ THE FOLLOWING!!!**

LED Light Kit Instruction Manual

What's Included in your LED Light Kit

- **LED Glass Clips and/or LED Pucks** – LED glass clips are placed directly onto glass, and emit light throughout the glass. LED pucks are attached to the surface without the need for any tools, and provide even light distribution.
- **RGB Receiver** – Transmits signal to the remote, allowing you to control your light settings. Your LED lights are 16 colored, and have different light settings.
- **Remote Control** – Allows you to easily turn your lights on/off and adjust the color as desired.
- **Splitter** – Used to connect your lights to your power supply.
- **USA Power Supply** – Used to power your LED light kit.

How to Install your Lights

1. Before installing, lay out all the products inside of the LED light kit package.
 - a. Connect each LED light to the splitter.
 - b. Connect the splitter to the RGB receiver.
 - c. Connect the RGB receiver to the power supply.
 - d. Plug the power supply into an outlet and press the ON button using the remote.
 - e. Check that everything is in working order, and then unplug your power supply & proceed with install.
2. If you have LED glass clips, you can clip them directly onto the back of the glass shelf. Never place LED lights where they are directly visible (on the front of the shelves), as they will be too bright.
3. If you have LED pucks, make sure the area where you want to attach your LED pucks is clean of dirt and debris, then attach the lights to the top of the shelves.
4. Finally, re-connect your power supply to the electrical outlet, and use your remote to change the lights to your desired color.
5. Enjoy your new TV stand lighting!

Troubleshooting

- **LED Lights Not Turning On**
 - Check your connections to make sure everything is plugged in.
 - The issue might be with the remote (refer to "Remote Not Working" section).
- **Remote Not Working**
 - Try moving closer to the receiver in case your remote is not in range.
 - Check to see if anything is blocking the signal between the remote and the receiver.
 - Make sure the receiver is exposed when installing.
- **Request a Free Replacement LED Light Kit**
 - If you are still experiencing issues after troubleshooting, you can request a replacement LED light kit shipped to you free of charge. To request a free replacement kit, please do one of the following:
 - Fill out the Parts Request form at www.mebleus.com/parts, or email help@meblefurniture.com.

FOR REPLACEMENT/MISSING PARTS:

www.meblefurniture.com/parts

FOR INSTRUCTION/ASSEMBLY MANUALS AND VIDEOS:

www.meblefurniture.com/assembly

ALL OTHER INQUIRIES:

help@meblefurniture.com

IF YOU ARE MISSING PARTS OR YOUR PRODUCT ARRIVED DAMAGED:

Please fill out a parts request form at
www.meblefurniture.com/parts

Replacement parts are shipped out in one business day. You will receive a tracking number via email once your parts request has been processed.

IF YOU ARE MISSING AN INSTRUCTION MANUAL OR NEED ASSEMBLY HELP:

Please visit www.meblefurniture.com/assembly to access our library of product assembly videos or to download product instruction manuals.

NOTICE REGARDING HIGH GLOSS PROTECTIVE FOIL AND PRODUCT CARE:

After removing the protective foil from the gloss fronts, the acrylic surface of the boards is still soft and easy to scratch. With air contact, the hygroscopic acrylic layer hardens, and the board becomes more resistant to scratches. It takes approximately 48 hours for the acrylic layer of the board to fully harden.

**DO NOT CLEAN, WIPE, OR POLISH THE
ACRYLIC FRONTS FOR 48 HOURS AFTER
REMOVING THE PROTECTIVE FOIL!!!**



help@meblefurniture.com