

PL- Przed rozpoczęciem zapoznać się z instrukcją montażu/ DE- Vor die montage, bitte beiliegende anweisungen folgen/ EN- Before starting, refer to the assembling advice in annex/ CZ- Před zahájením naleznete v montážním návodu/ HR- Prije početka, uzmite upute za montažu u prilogu

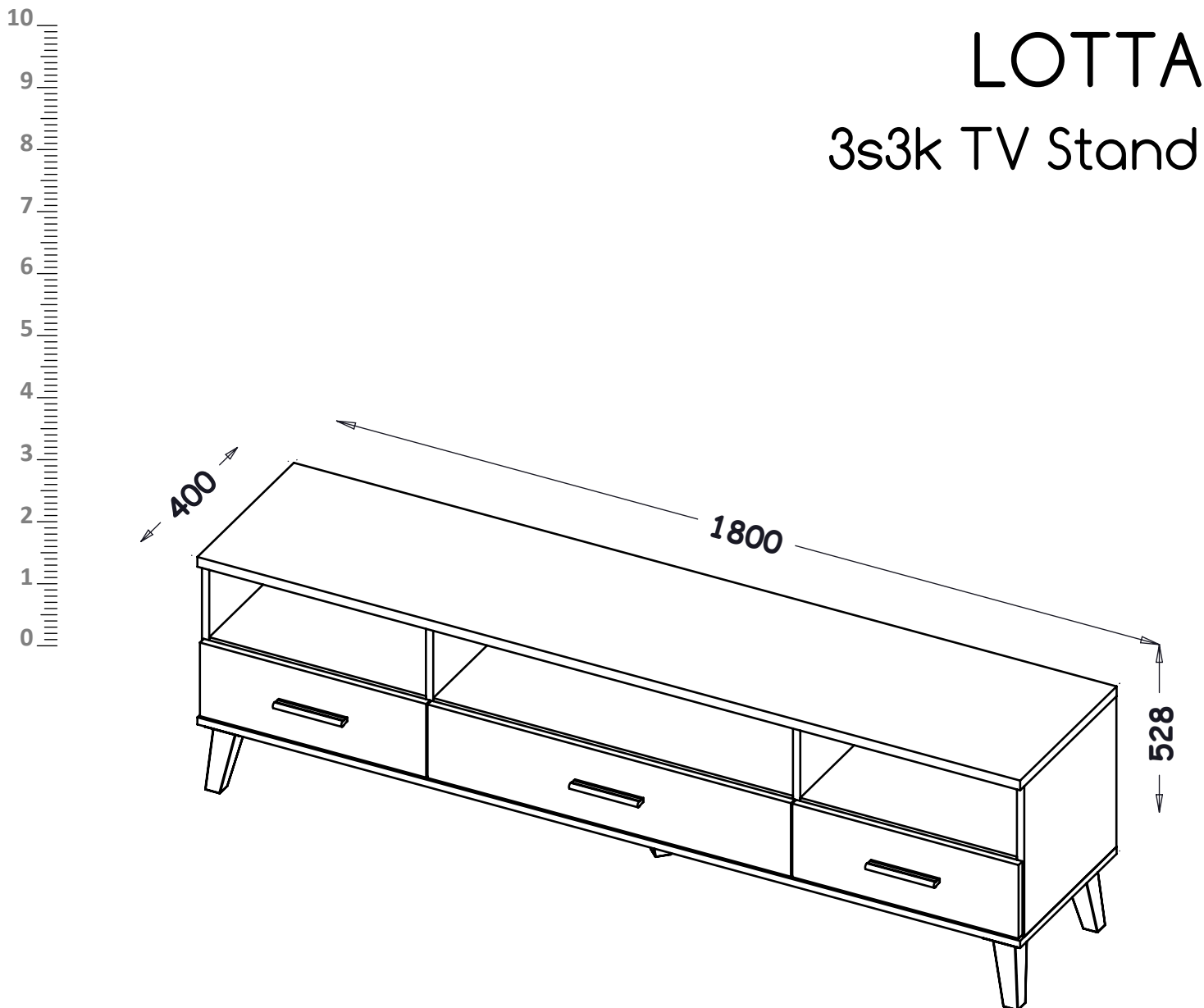

PL- Narzędzia niezbędne do montażu (nie dostarczone przez producenta)/ DE- Für die Montage notwendige Werkzeuge (nicht vom Hersteller mitgeliefert)/ EN- Tools required for assembly (not provided by the manufacturer)/ CZ- Nástroje nezbytné pro montáž (nejsou dodávány výrobcem)/ HR- Alat potreban za montažu (nije osiguran od strane proizvođača)

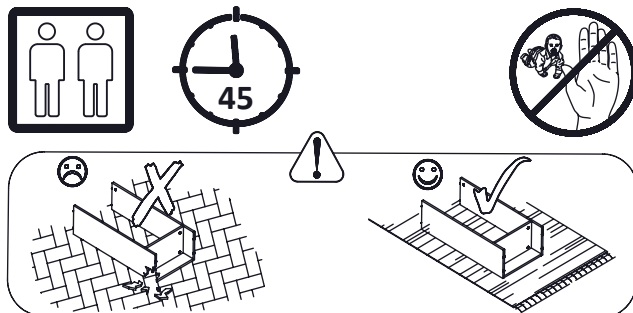

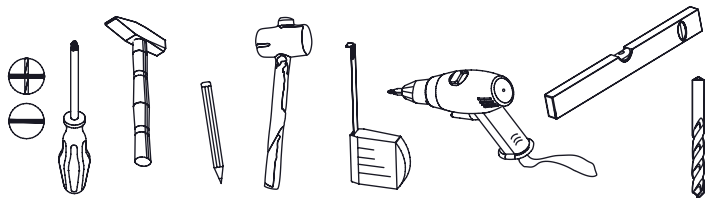

PL - UWAGA!

W przypadku reklamacji prosimy o podanie numeru serii znajdującego się na kartonie. W związku z tym prosimy o zachowanie opakowań do momentu zmontowania mebla. W przypadku stwierdzenia uszkodzenia któregoś z elementów, prosimy nie montować modułu, którego częścią jest dany element.

DE - HINWEIS!

Im Falle einer Reklamation geben Sie bitte die Seriennummer, die sich auf der Verpackung befindet. Daher bitten wir Sie immer die Verpackung solange aufzubewahren, bis die Möbelstücke vollständig montiert sind. Sollten Schäden an Einzelteilen auftreten, bitte sehen Sie von der Montage des Moduls ab.

EN - ATTENTION!

In case of claim please give us series number which you can find on the box. Thereupon please keep the package until montage of furniture is done. In case verified damage any of elements, please do not mount module, which is a parts of particular element.

CZ - POZOR!

Při reklamaci prosíme o uvedení čísla šarže, které se nachází na obale. V souvislosti s tímto prosíme o uchování obalů do okamžiku složení nábytku. V případě poškození některého z dílů, prosíme neskládat model, jehož součástí poškozený díl je.









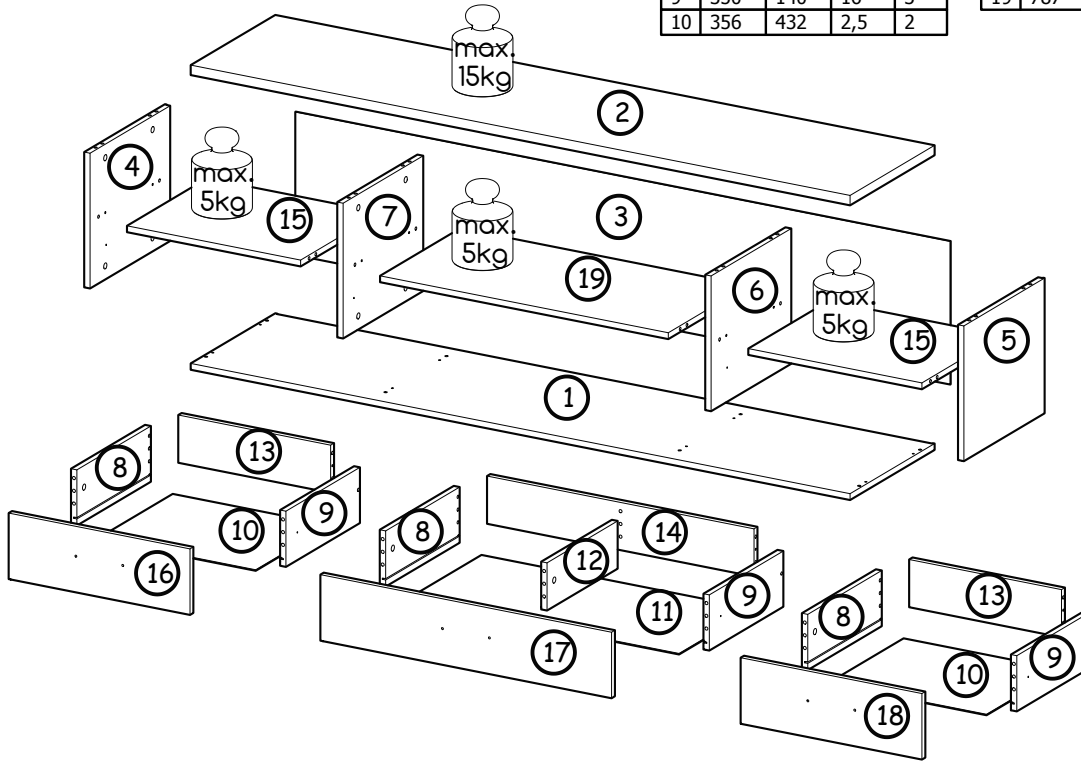

HR - PAŽNJA!

U slučaju reklamacije, molimo Vas da nam date serijski broj koji možete pronaći na ambalaži. Molimo Vas da zadržite ambalažu sve dok nije kompletna montaža proizvoda. Ukoliko je uočeno oštećenje bilo kojeg elementa, molim Vas da ne montirate oštećeni dio.

Nr	Xmm	Ymm	Zmm	Szt.
1	1800	400	16	1
2	1800	400	22	1
3	1788	360	2,5	1
4	340	382	16	1
5	340	382	16	1
6	340	379	16	1
7	340	379	16	1
8	350	140	16	3
9	350	140	16	3
10	356	432	2,5	2

Nr	Xmm	Ymm	Zmm	Szt.
11	356	745	2,5	1
12	120	334	16	1
13	416	120	16	2
14	729	120	16	1
15	474	379	16	2
16	495	166	16	1
17	795	166	16	1
18	495	166	16	1
19	787	379	16	1

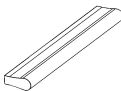
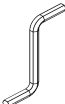

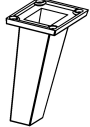
B1 56x ø8x35 	K1 35x ø15x12 	K5 35x 34mm 	I20 15x ø4/ø17 	G20 24x ø5x13 	H12 6x 300mm 
W4 98x 	A1 7x ø7x50 	G16 6x ø4x27 	E6 3x 150mm 	W2 1x 4mm 	G11 20x 4x20 
P42 5x h150 					

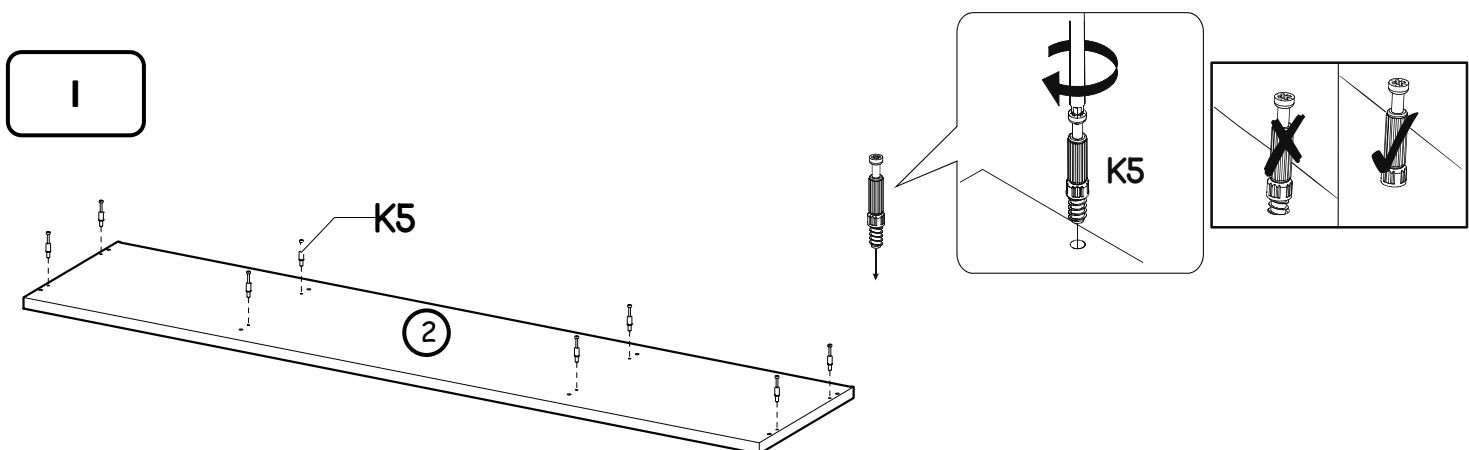

II

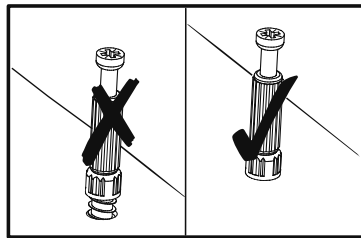
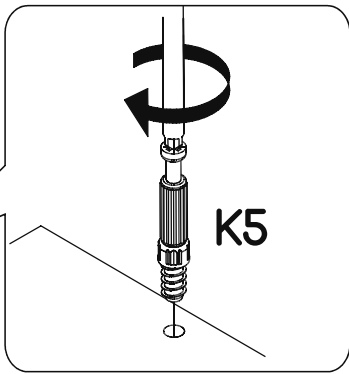
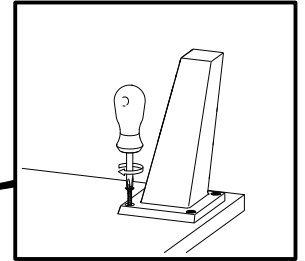
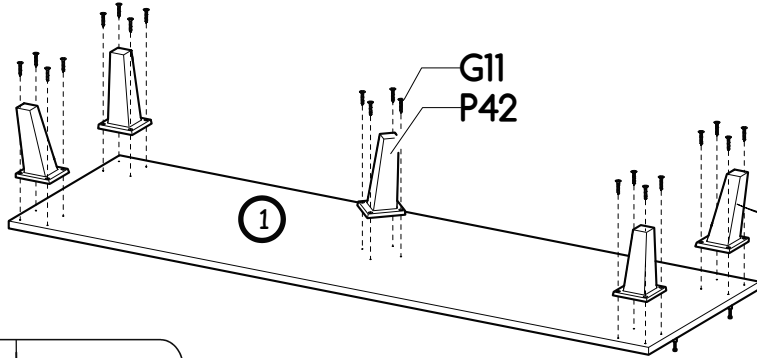
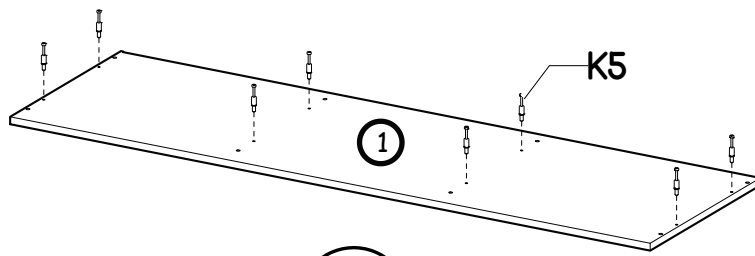

III

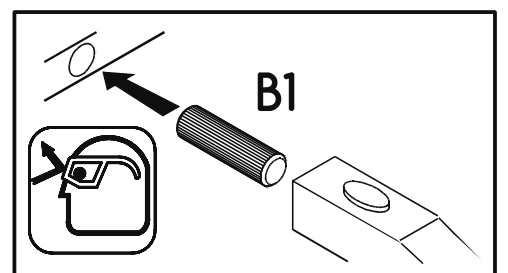
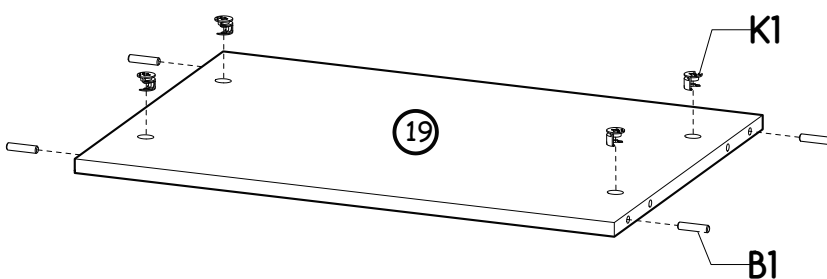
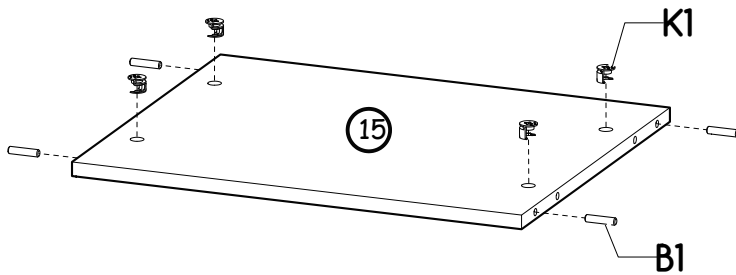
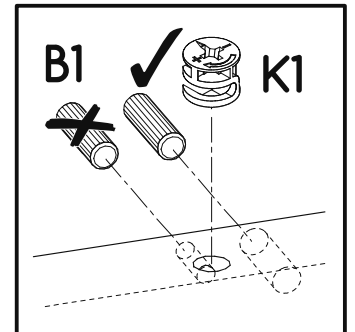
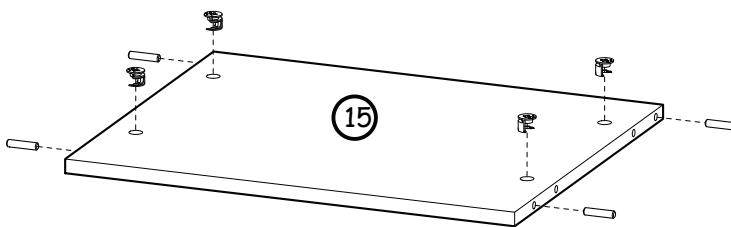

IV

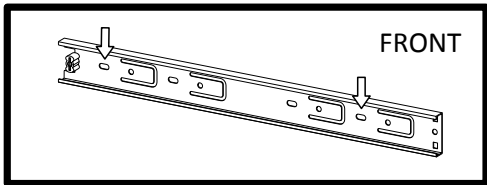
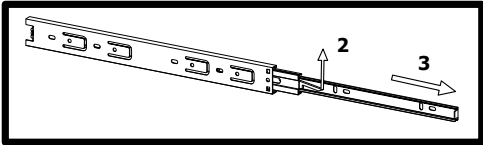
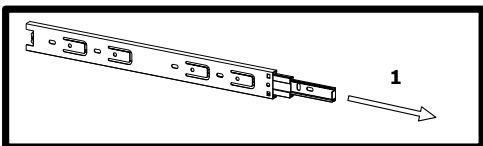
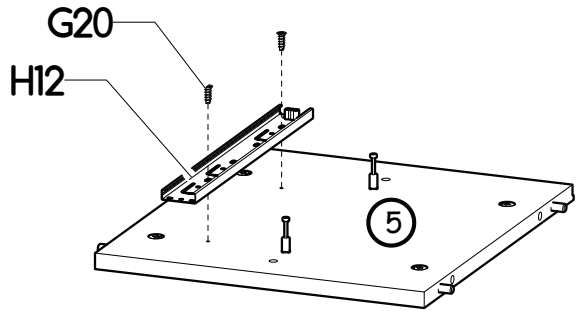
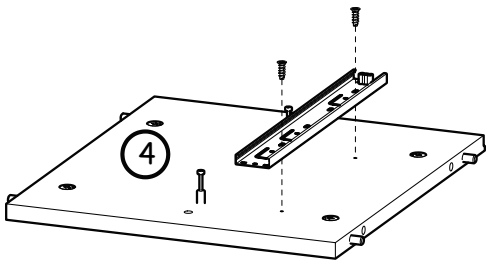
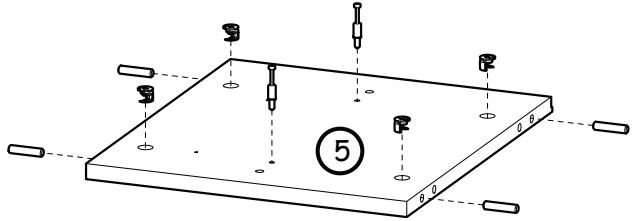
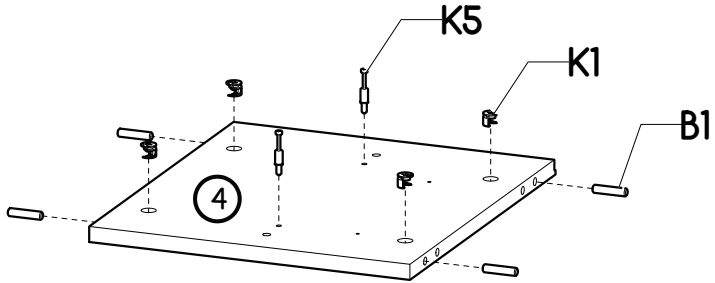
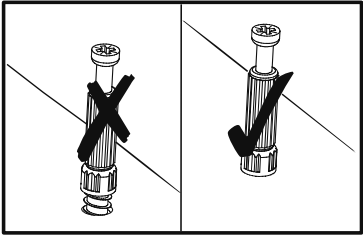
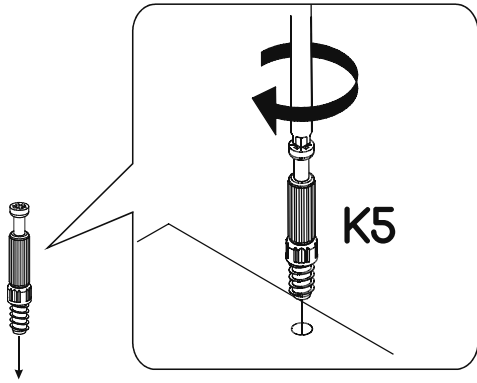
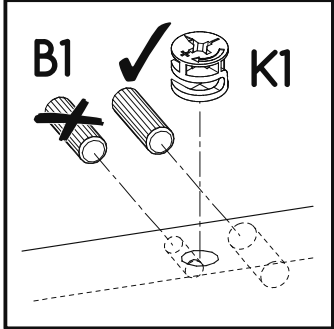
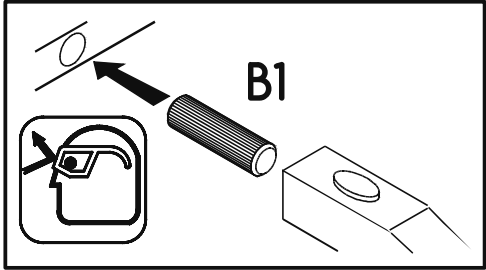

V

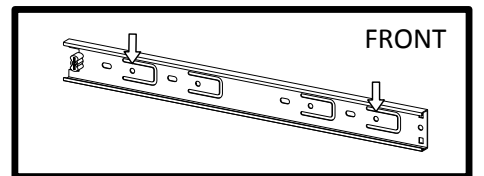
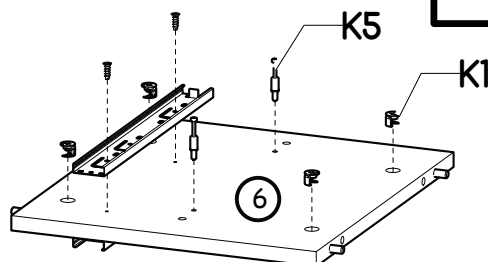
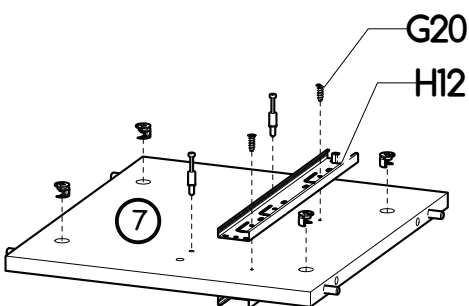
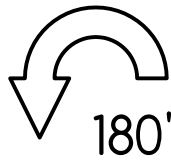
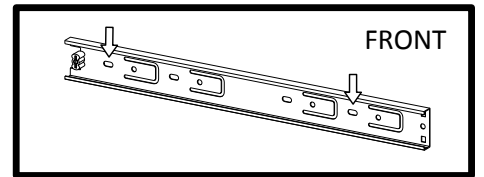
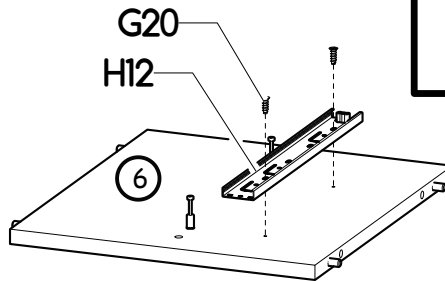
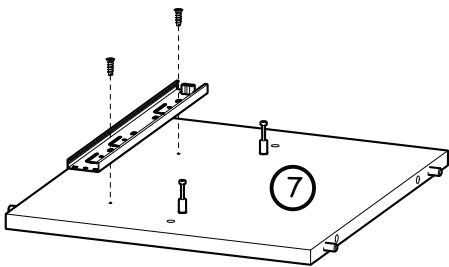
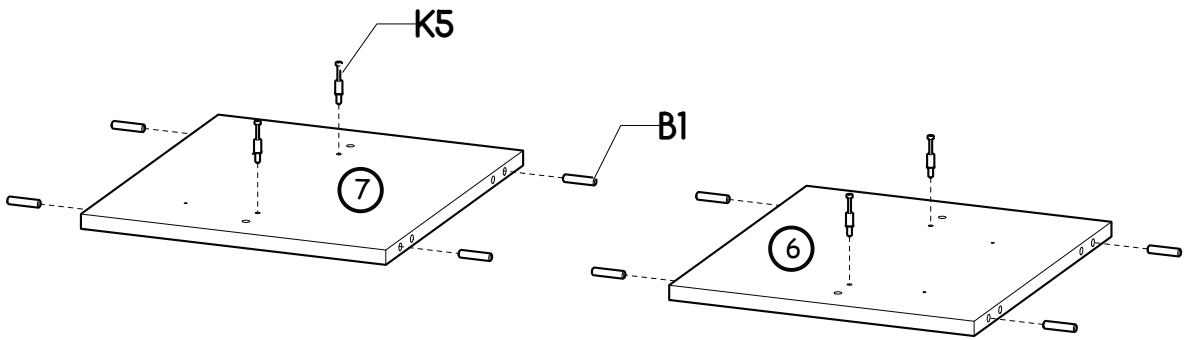
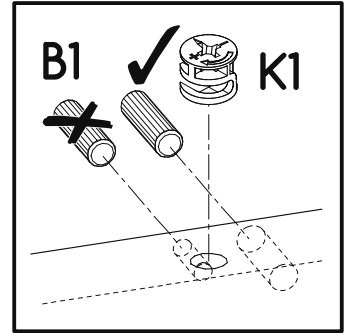
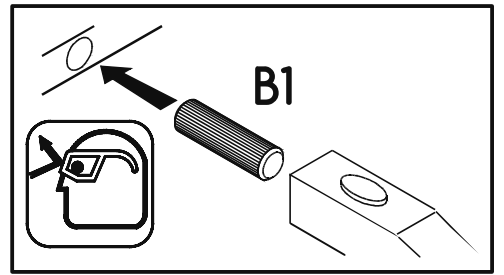
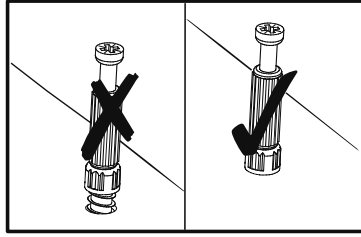
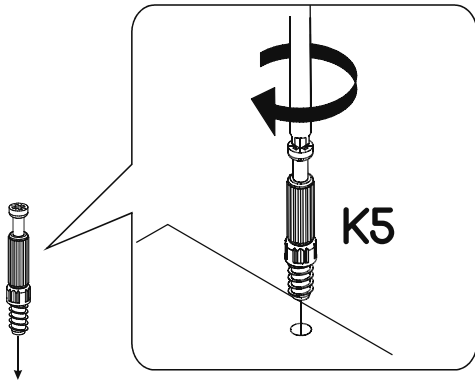

VI

i

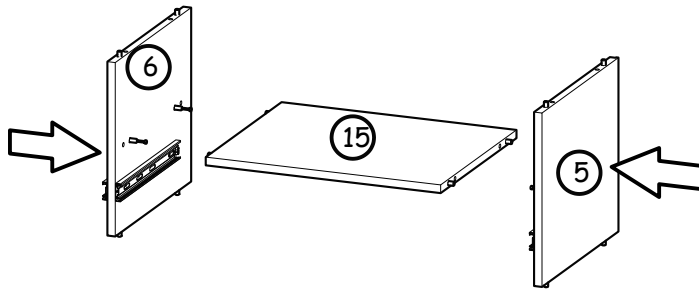
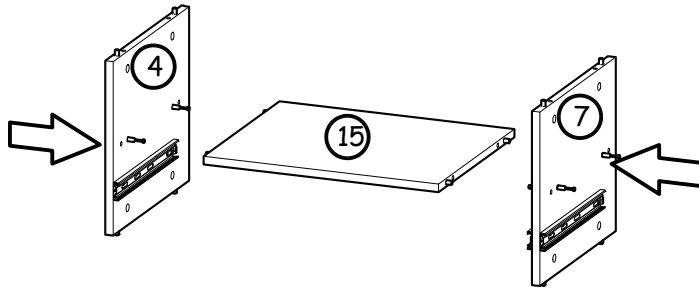
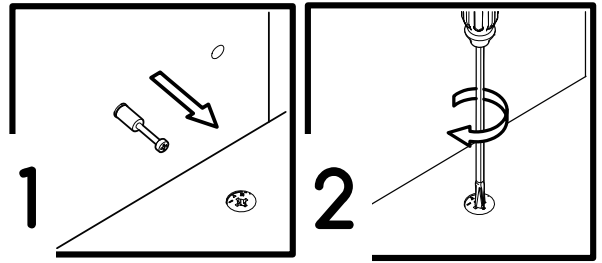

VII

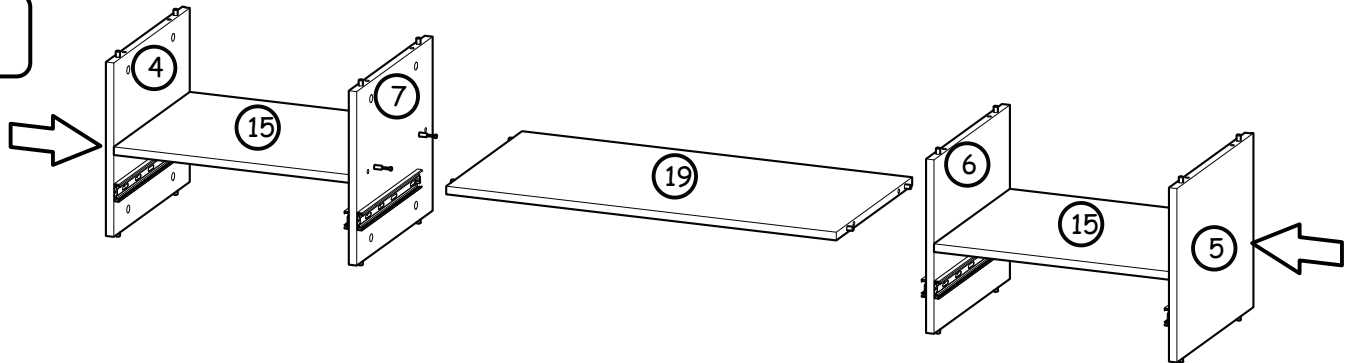

VIII

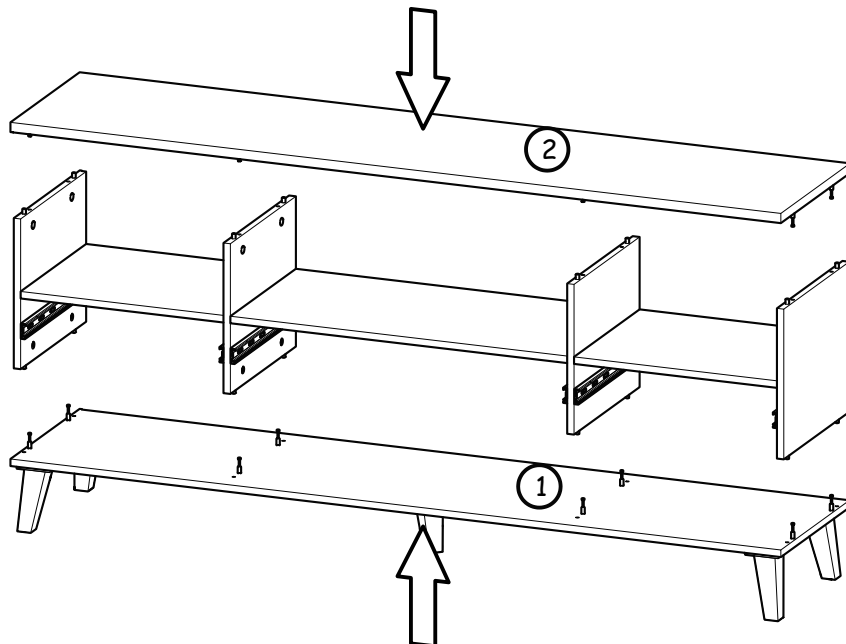

IX

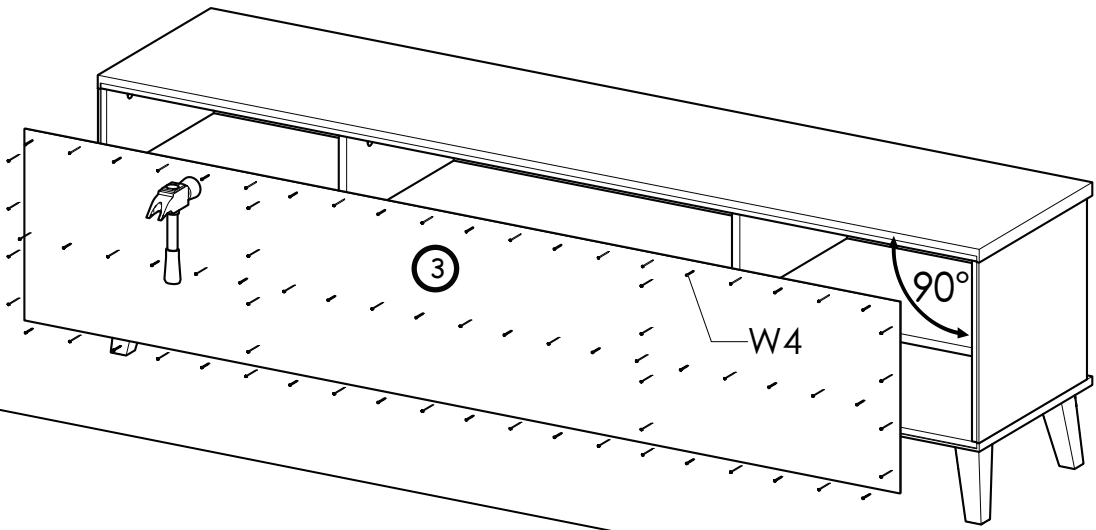

X

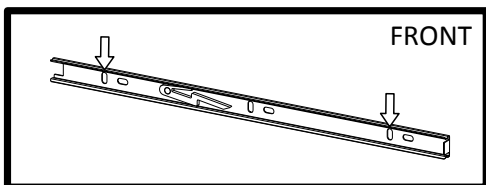
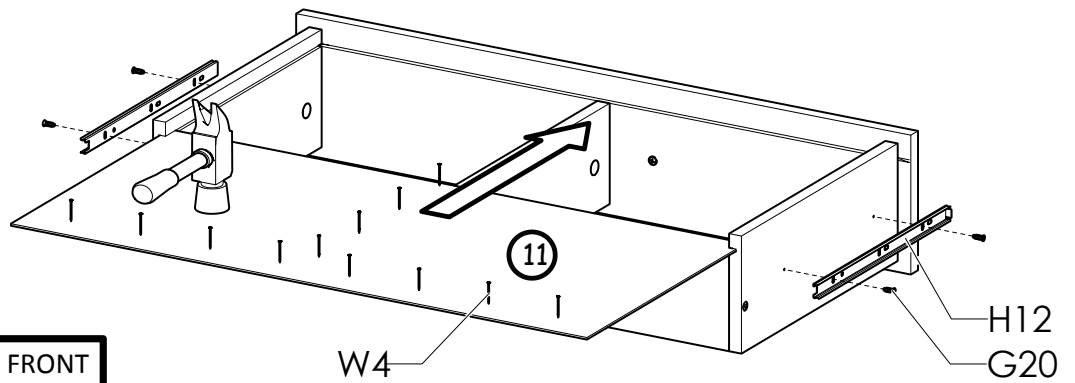
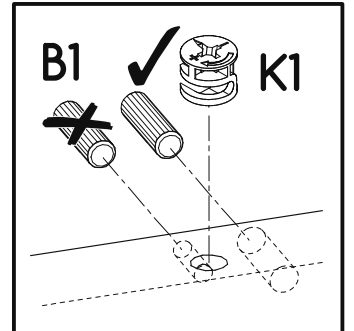
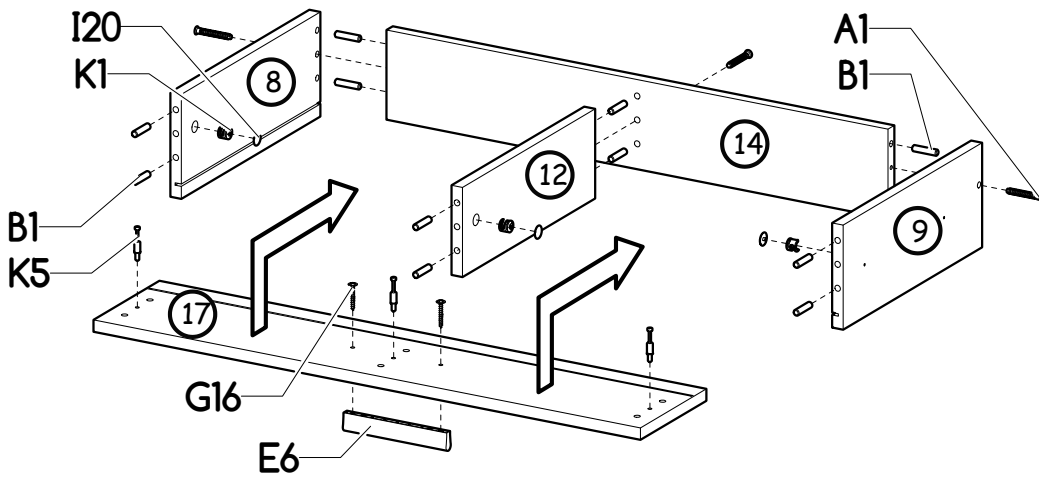
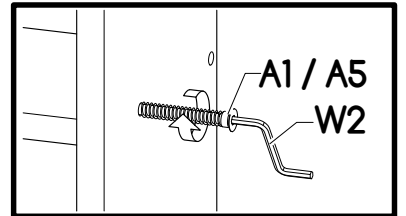
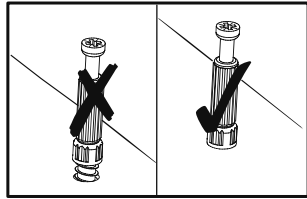
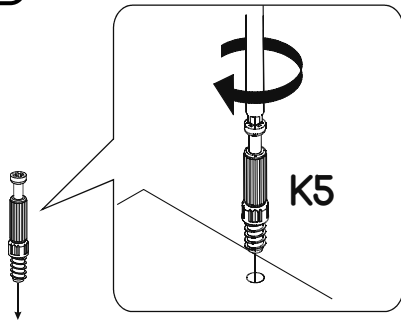

XI

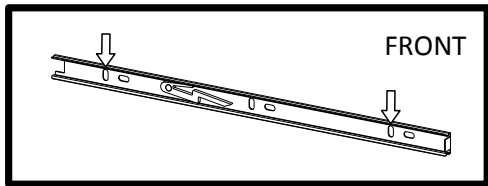
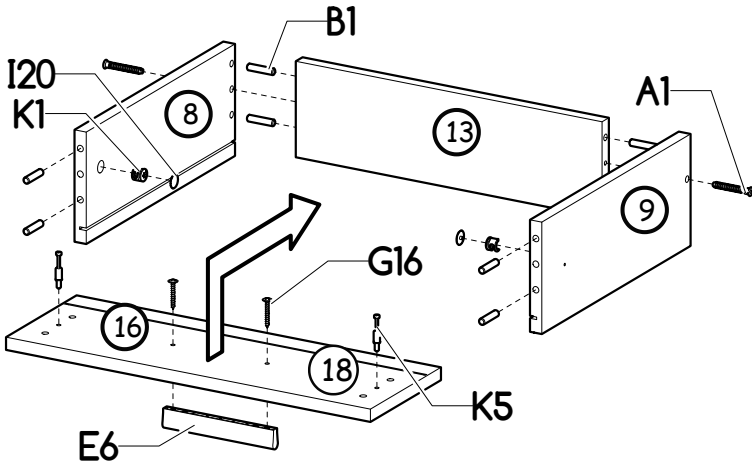

x2

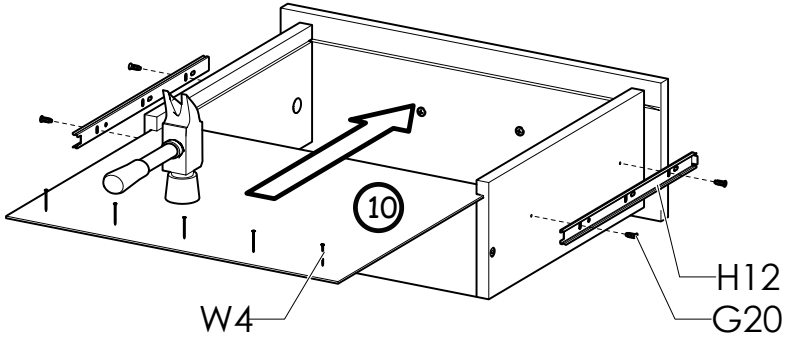

XII

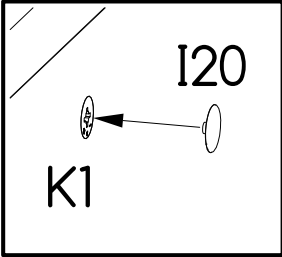
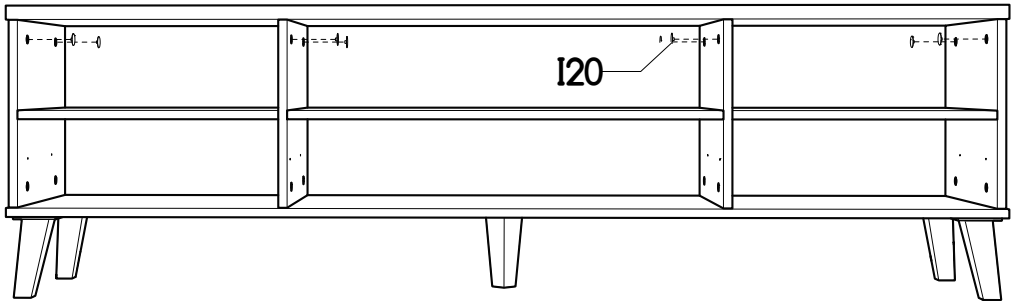

XIII

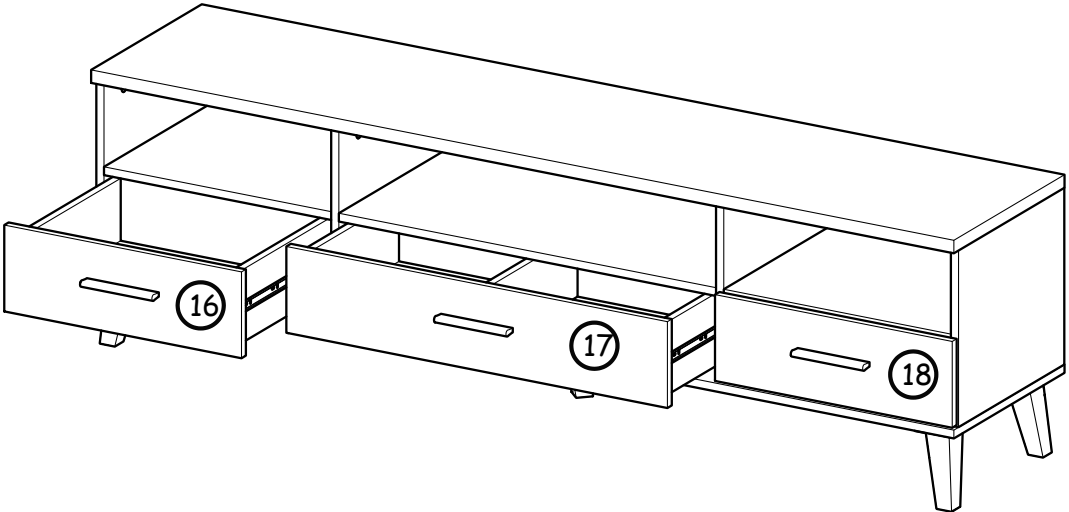

**Claim your extended 90 day product warranty
by registering your product at
www.meblefurniture.com/register**

**ATTENTION: DO NOT RETURN THIS PRODUCT!!!
PLEASE READ THE FOLLOWING!!!**

FOR REPLACEMENT/MISSING PARTS:

www.meblefurniture.com/parts

**FOR INSTRUCTION/ASSEMBLY MANUALS
AND VIDEOS:**

www.meblefurniture.com/assembly

ALL OTHER INQUIRIES:

help@meblefurniture.com

**IF YOU ARE MISSING PARTS OR YOUR
PRODUCT ARRIVED DAMAGED:**

Please fill out a parts request form at
www.meblefurniture.com/parts

Replacement parts are shipped out in one business day. You will receive a tracking number via email once your parts request has been processed.

**IF YOU ARE MISSING AN INSTRUCTION
MANUAL OR NEED ASSEMBLY HELP:**

Please visit www.meblefurniture.com/assembly to access our library of product assembly videos or to download product instruction manuals.

**NOTICE REGARDING HIGH GLOSS
PROTECTIVE FOIL AND PRODUCT CARE:**

After removing the protective foil from the gloss fronts, the acrylic surface of the boards is still soft and easy to scratch. With air contact, the hygroscopic acrylic layer hardens, and the board becomes more resistant to scratches. It takes approximately 48 hours for the acrylic layer of the board to fully harden.

**DO NOT CLEAN, WIPE, OR POLISH THE
ACRYLIC FRONTS FOR 48 HOURS AFTER
REMOVING THE PROTECTIVE FOIL!!!**

