

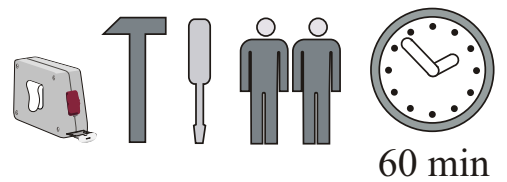

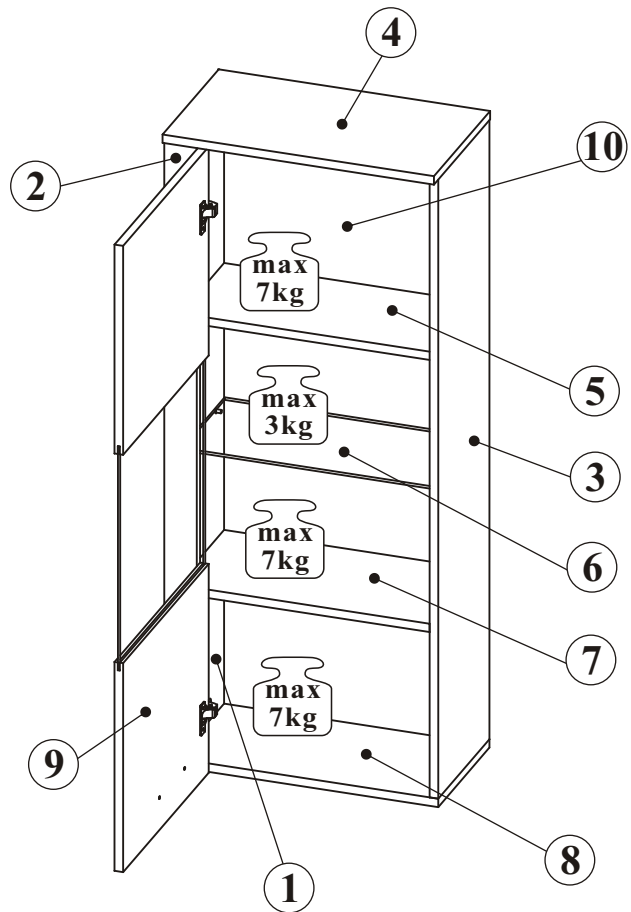

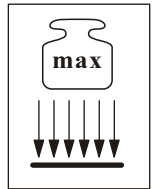

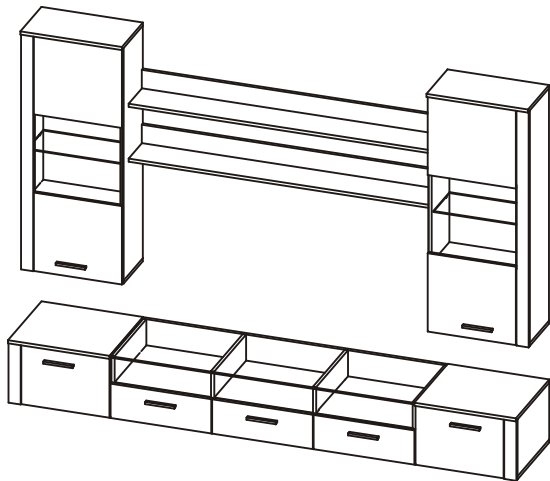



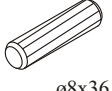

FRESH 28 -- FR-C-23

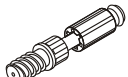

60 min

NO	Dim.		Col.-No	Qty
1	1187	260	1	1
2	1203	60	1	1
3	1187	260	1	1
4	501	285	1	1
5	465	220	1	1
6	464	220	1	1
7	465	240	1	1
8	499	260	1	1
9	1199	434	1	1
10	477	1198	1	1

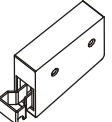
FRESH - 28 -- FR-C - 23

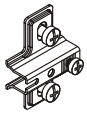
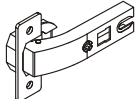
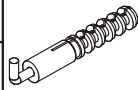
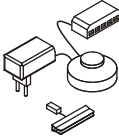
A1 x16  ø8x36	G6 x4 	G20 x4 	S1 x10 	D10 x4  ø3,5x13	D6 x4  US ø3,5x30
B5 x16  ø15x12	B4 x16 	G5 x16 	UL2 x1 	UP6 x2  øUP4x30	ZR1 x2 
G2 x1 	E12 x2 	E13 x2 	KR2 x2 	UL1 x1 	

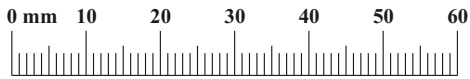

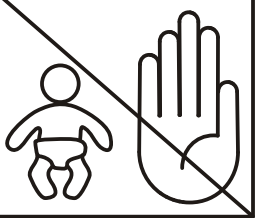

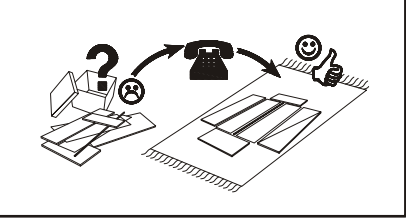

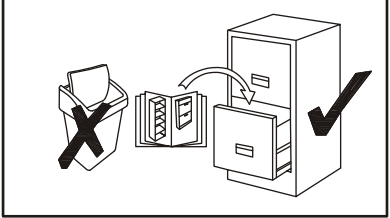

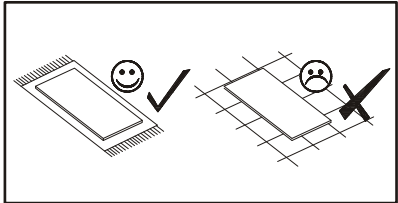

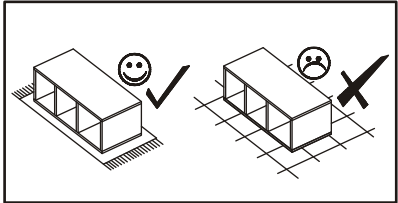

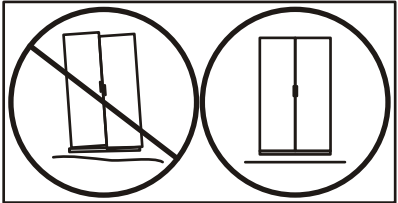

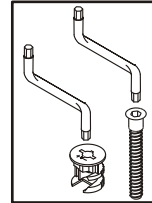











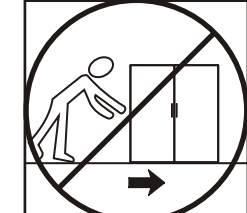

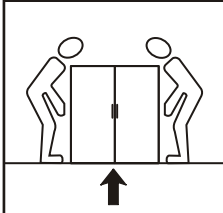

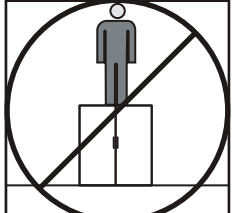

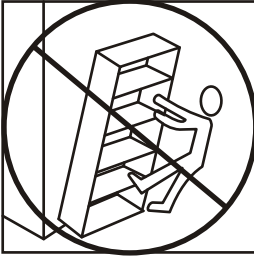

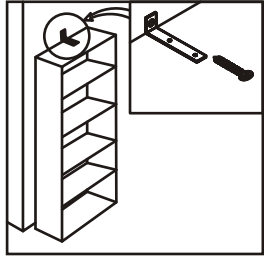

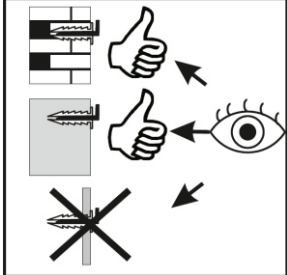

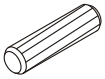

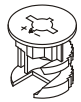
A1	
x16	ø8x36

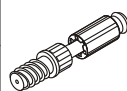
B5	
x16	ø15x12

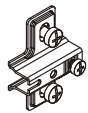
B4	
x8	

E12	
x2	

G6	
x4	

G20	
x4	

1

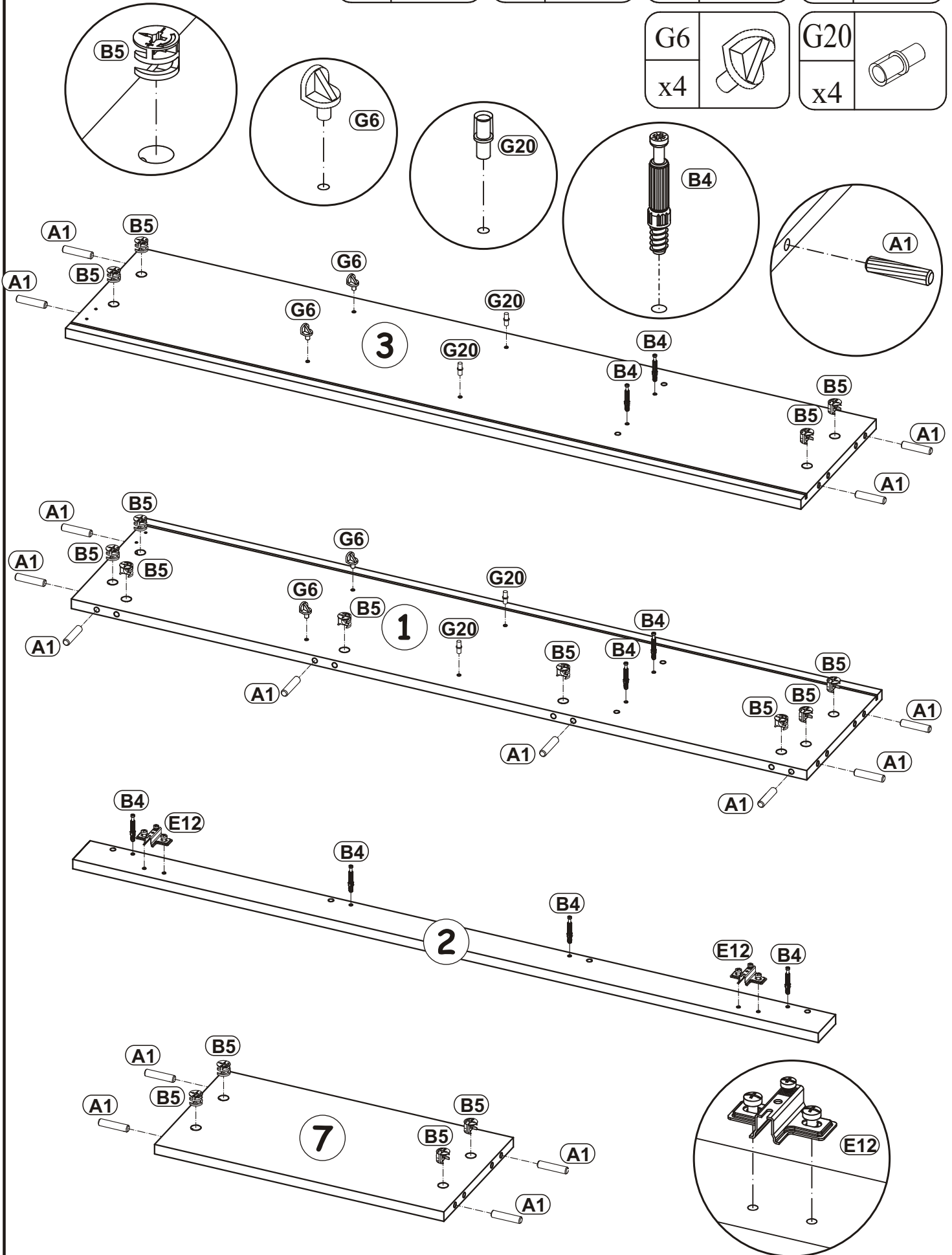

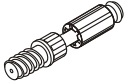
B4	
x8	

2

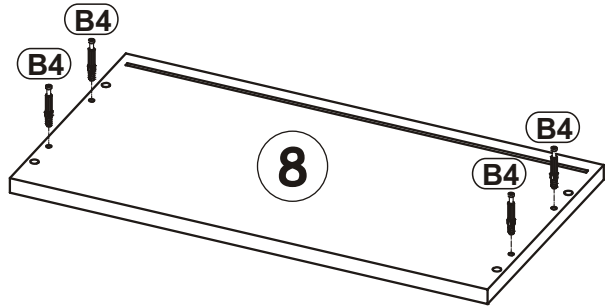
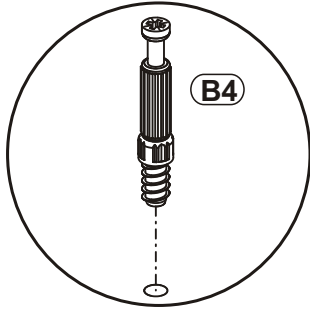
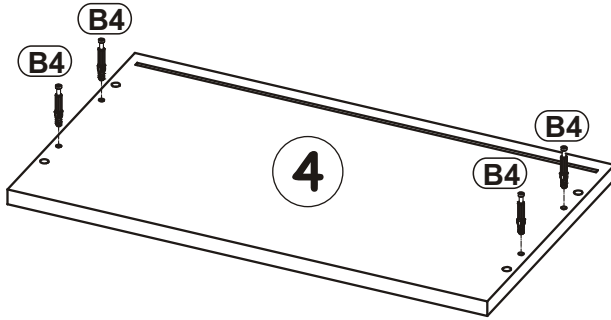

3

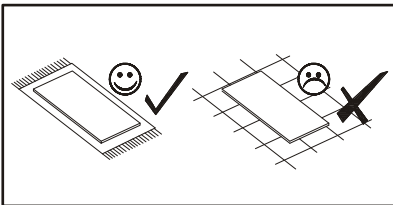

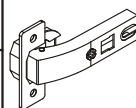

E13	
x2	

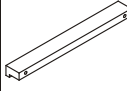
D10	
x4	ø3,5x13

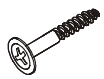
UL2	
x1	

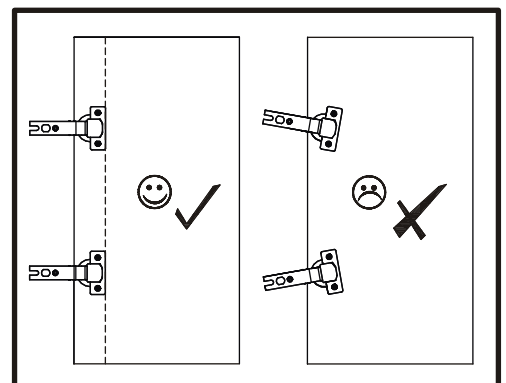
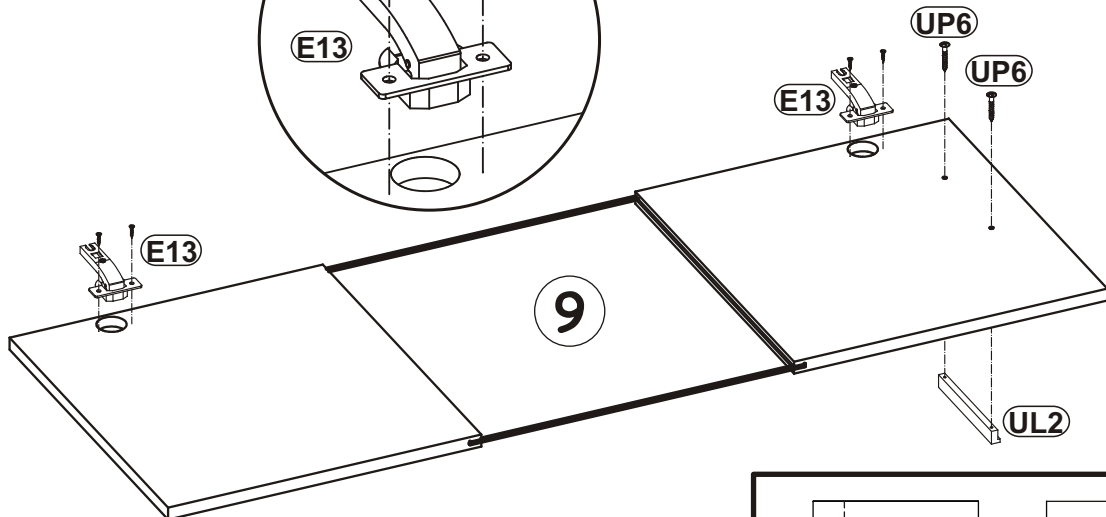
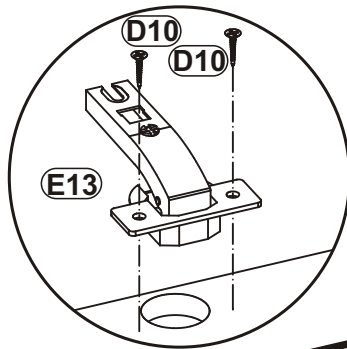
UP6	
x2	øUP4x30



G5	
x4	

4

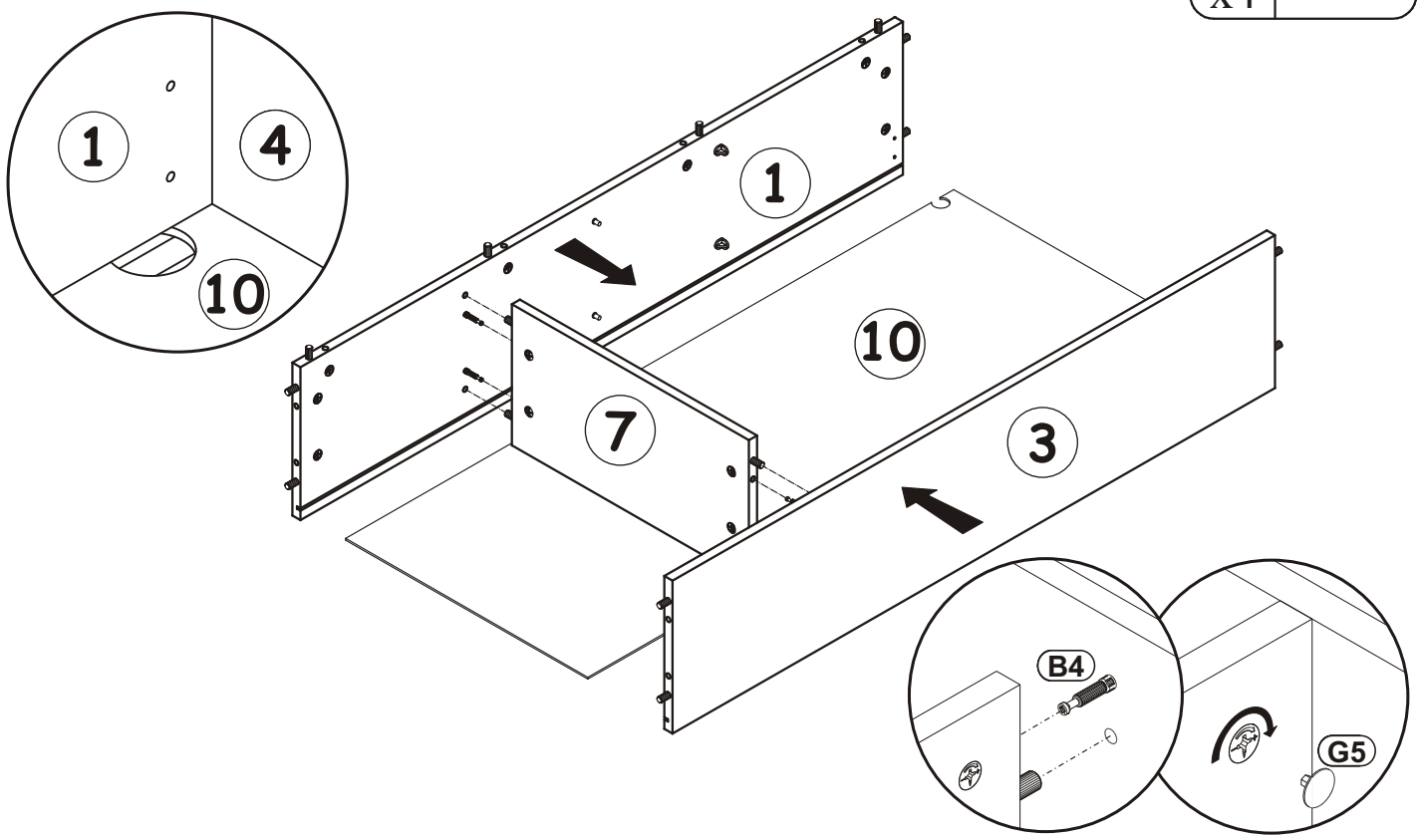

5

G5	
x12	

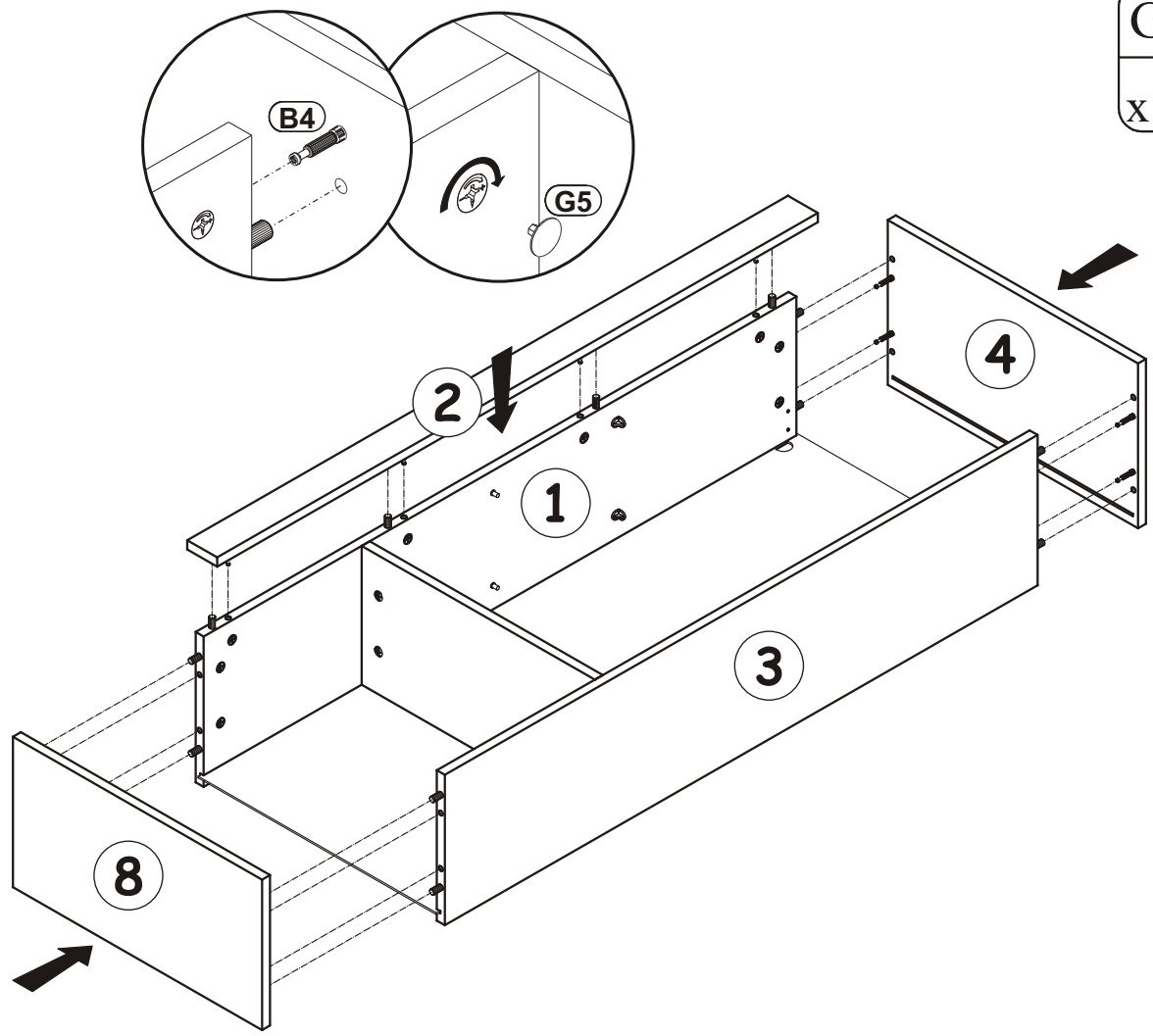

6

$X=Y$ 90°

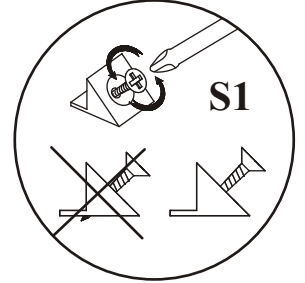
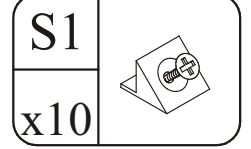
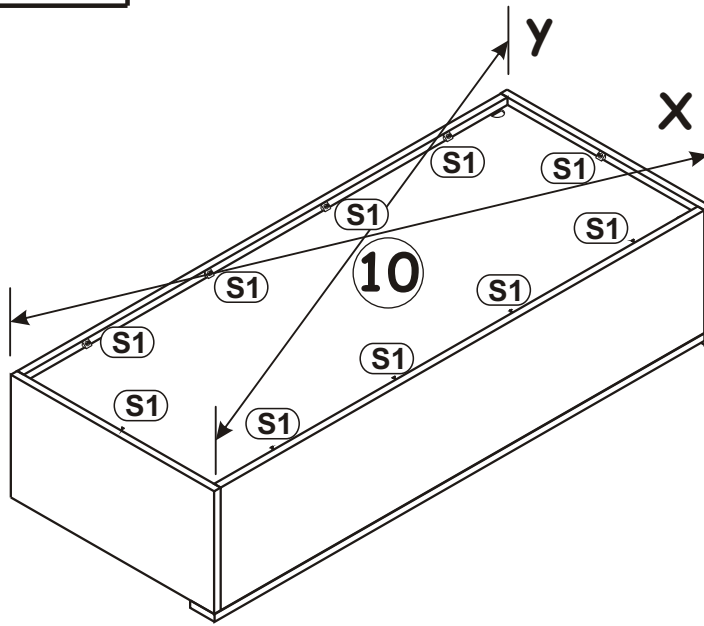

7

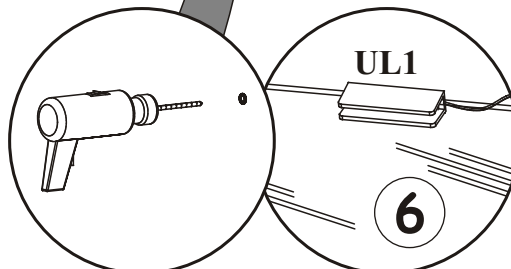
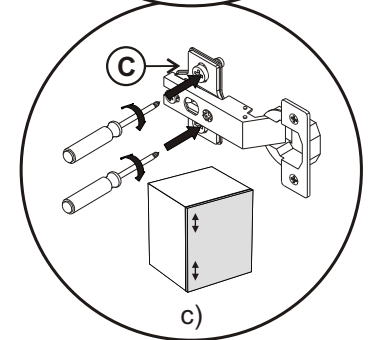
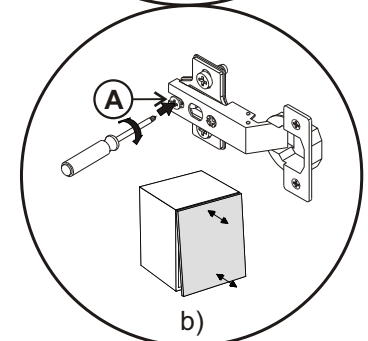
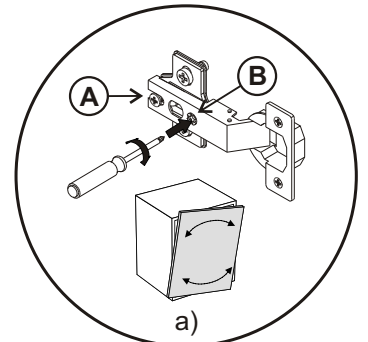
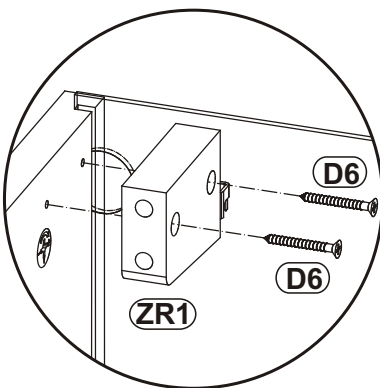
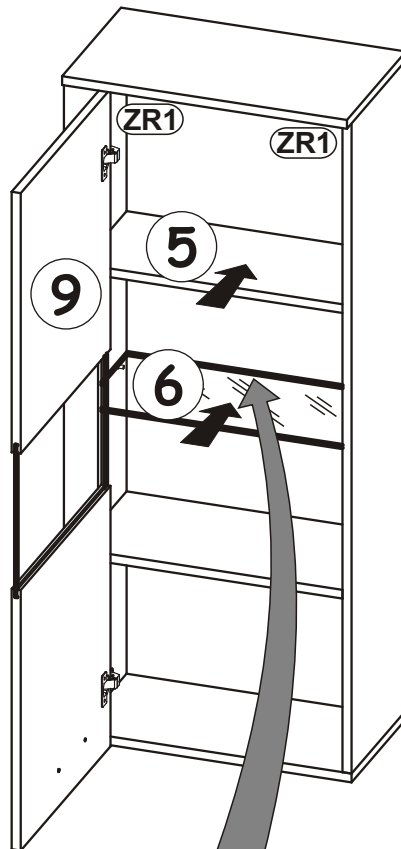
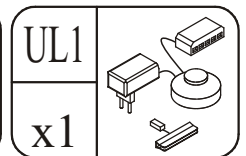
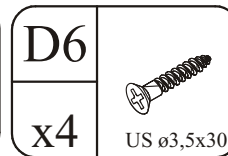
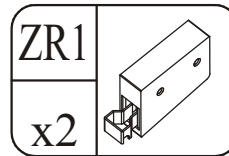

8

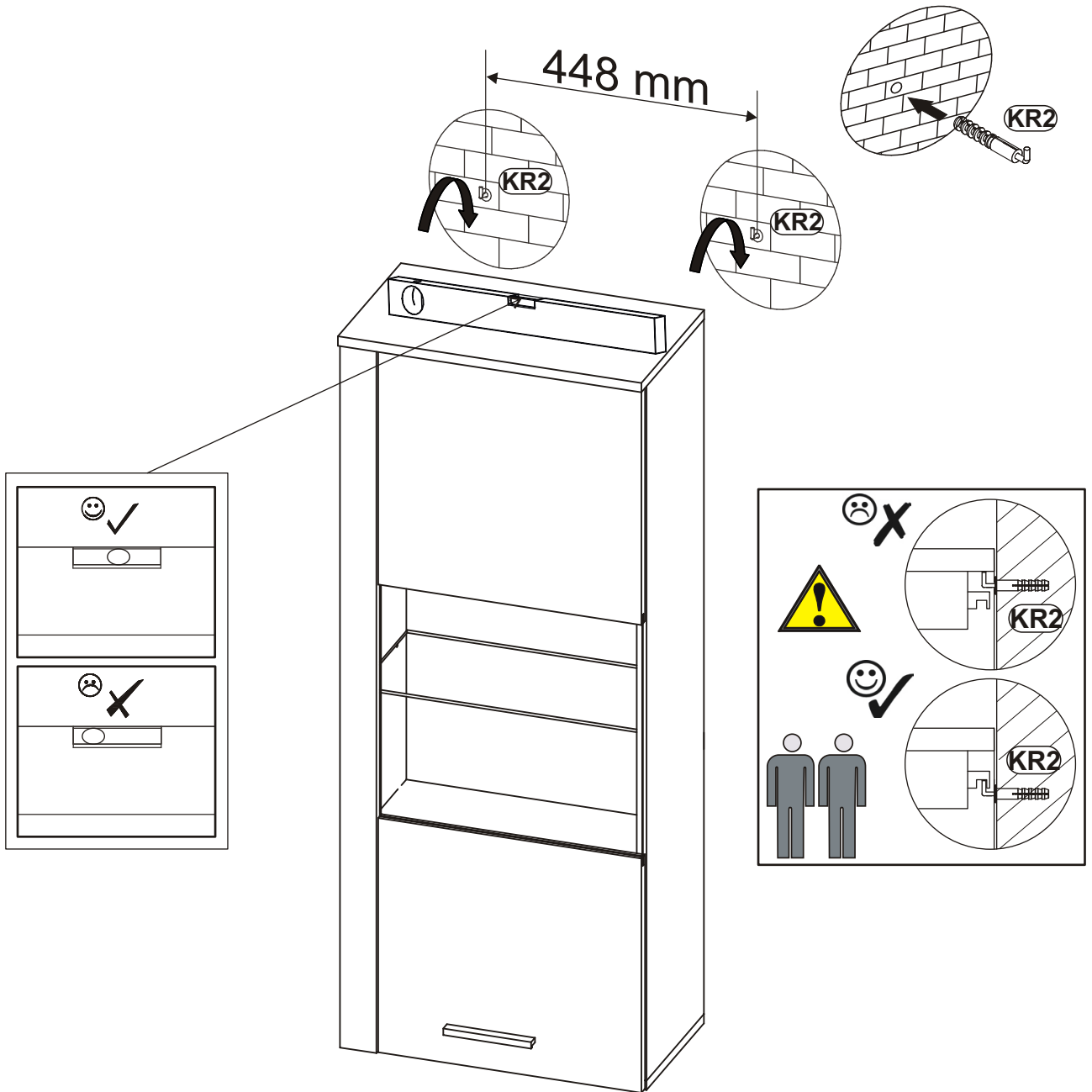
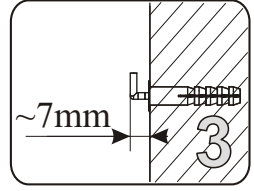
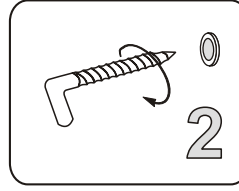
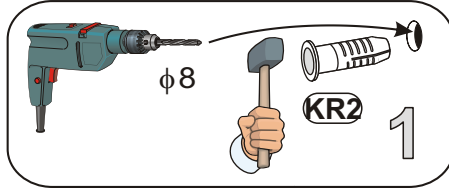
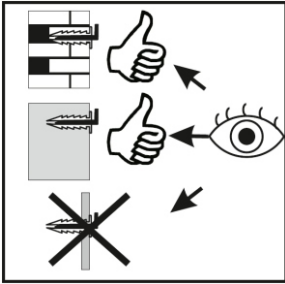
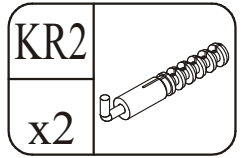

FRESH 28 -- FR-C-24

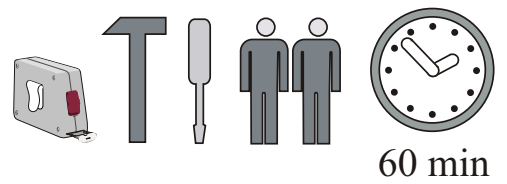
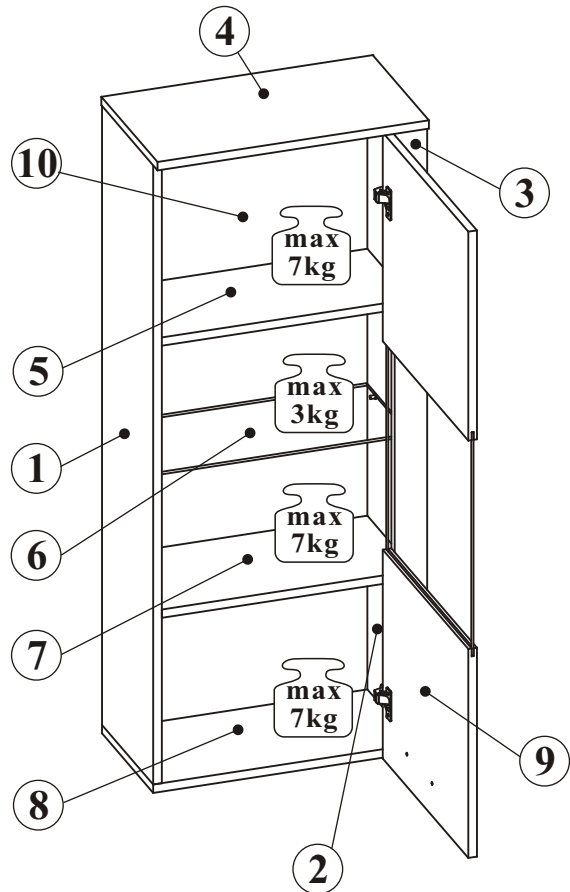
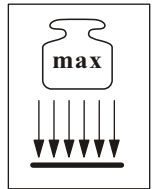
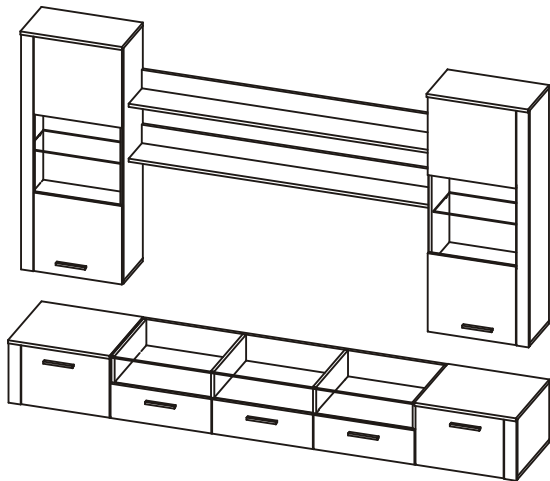

60 min

NO	Dim.	Col.-No	Qty
1	1187 260	1	1
2	1187 260	1	1
3	1203 60	1	1
4	501 285	1	1
5	465 220	1	1
6	464 220	1	1
7	465 240	1	1
8	499 260	1	1
9	1199 434	1	1
10	477 1198	1	1

A1 x16 ø8x36	G6 x4	G20 x4	S1 x10	D10 x4 ø3,5x13	D6 x4 US ø3,5x30
B5 x16 ø15x12	B4 x16	G5 x16	UL2 x1	UP6 x2 øUP4x30	ZR1 x2
G2 x1	E12 x2	E13 x2	KR2 x2	UL1 x1	

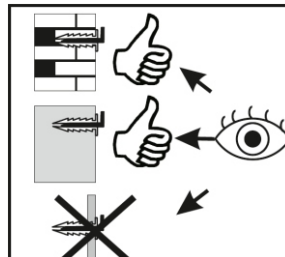
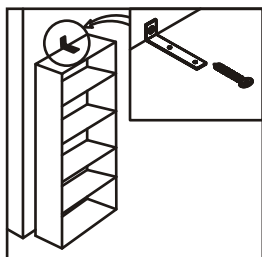
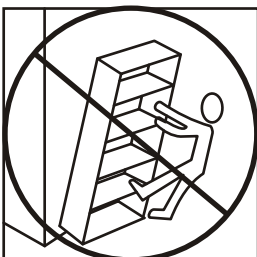
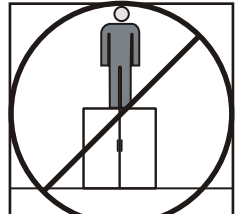
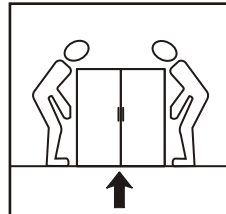
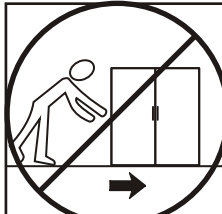
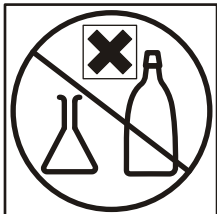
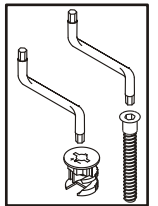
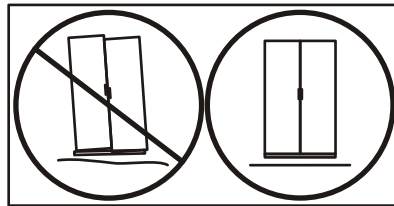
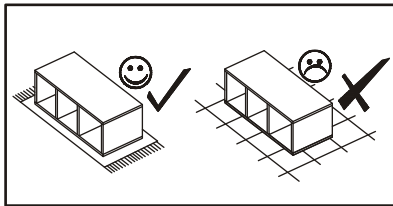
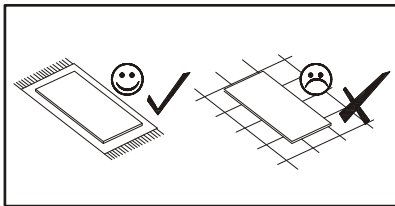
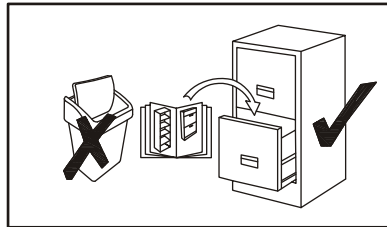
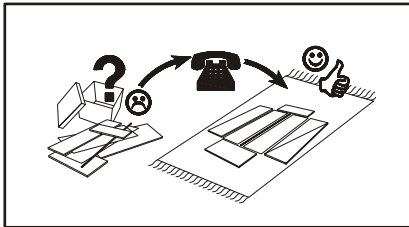
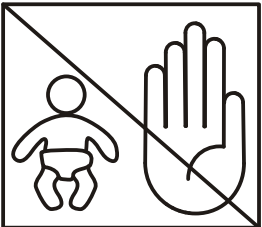
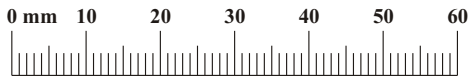

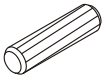

1

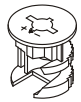
A1	
x16	ø8x36

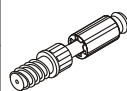
B5	
x16	ø15x12

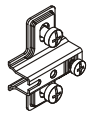
B4	
x8	

E12	
x2	

G6	
x4	

G20	
x4	

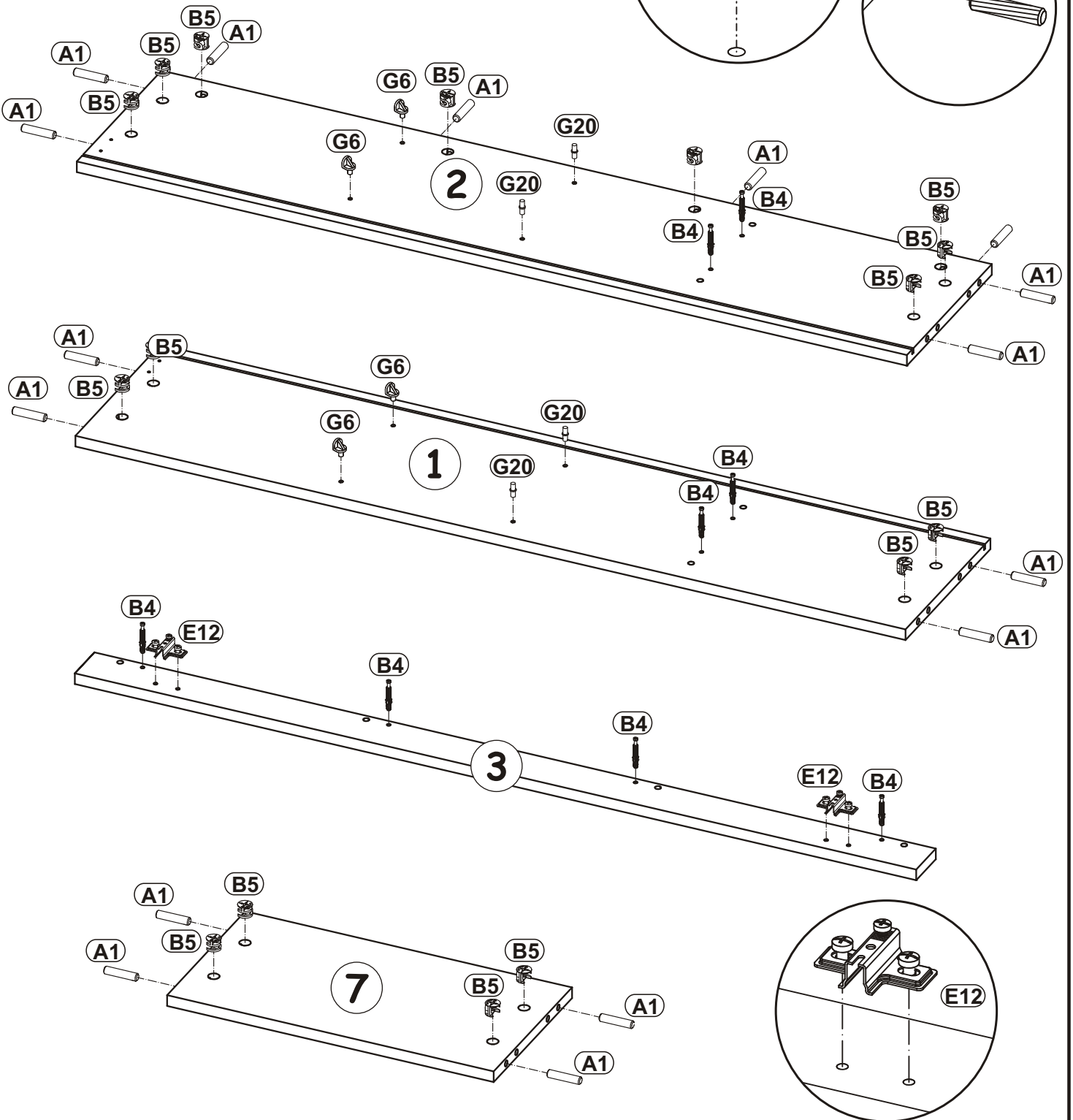
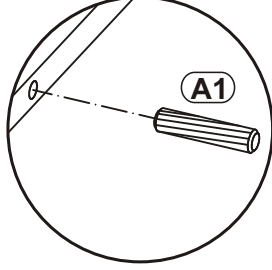
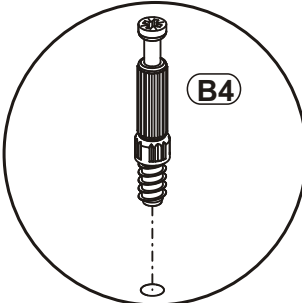
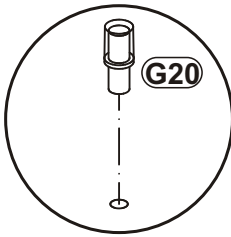
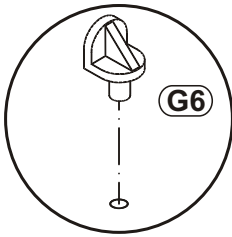
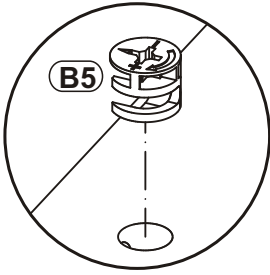

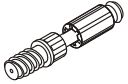

B4	
x8	

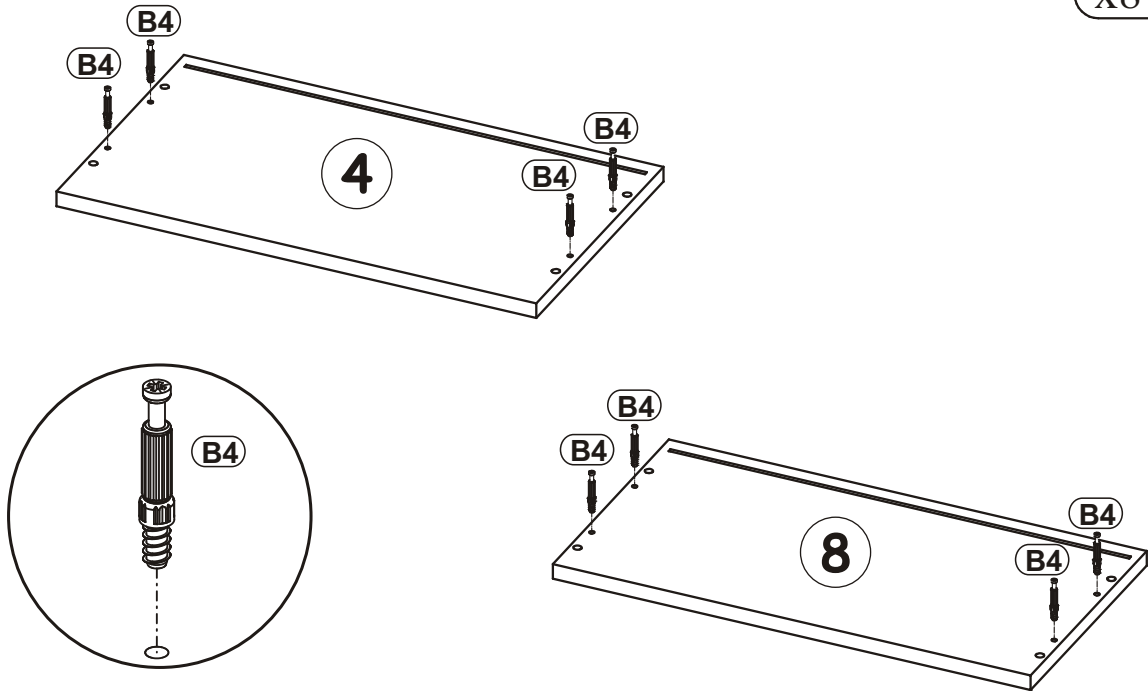
2

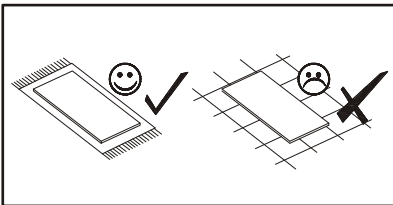

3

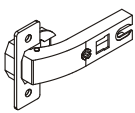

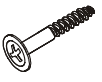
E13		D10		UL2		UP6	
x2		x4	ø3,5x13	x1		x2	øUP4x30

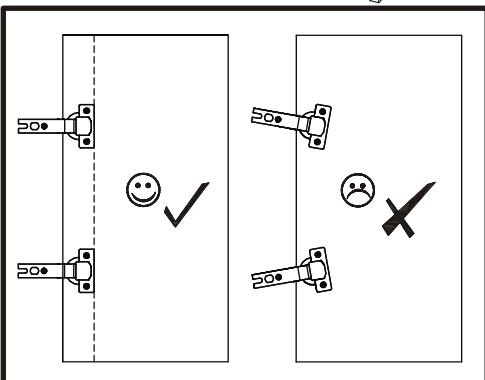
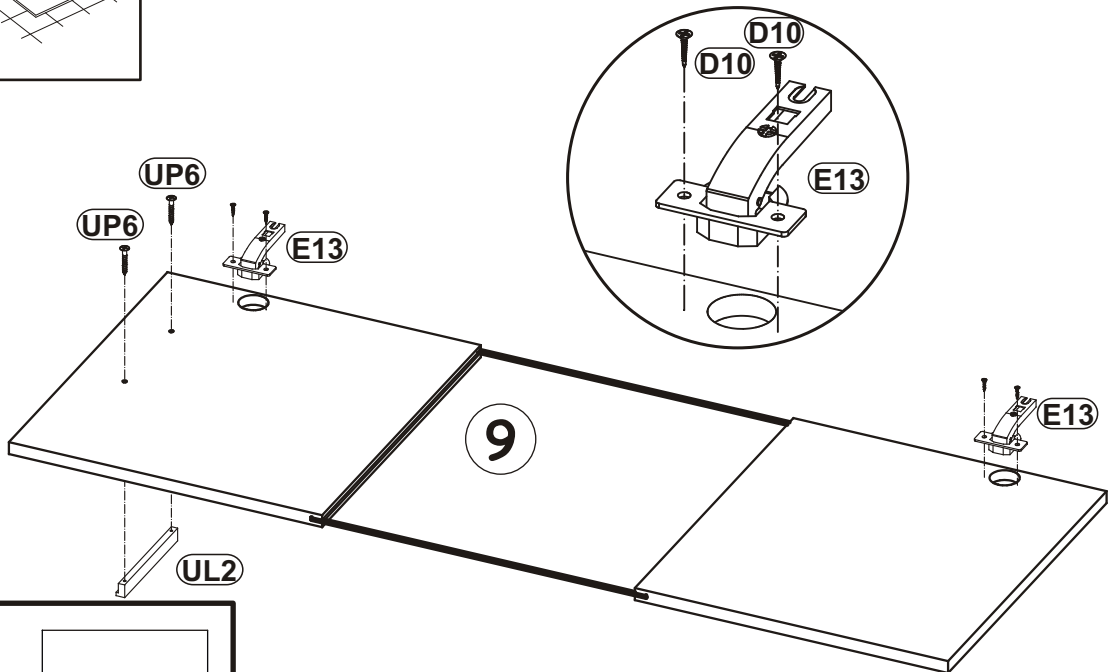

G5	
x4	

4

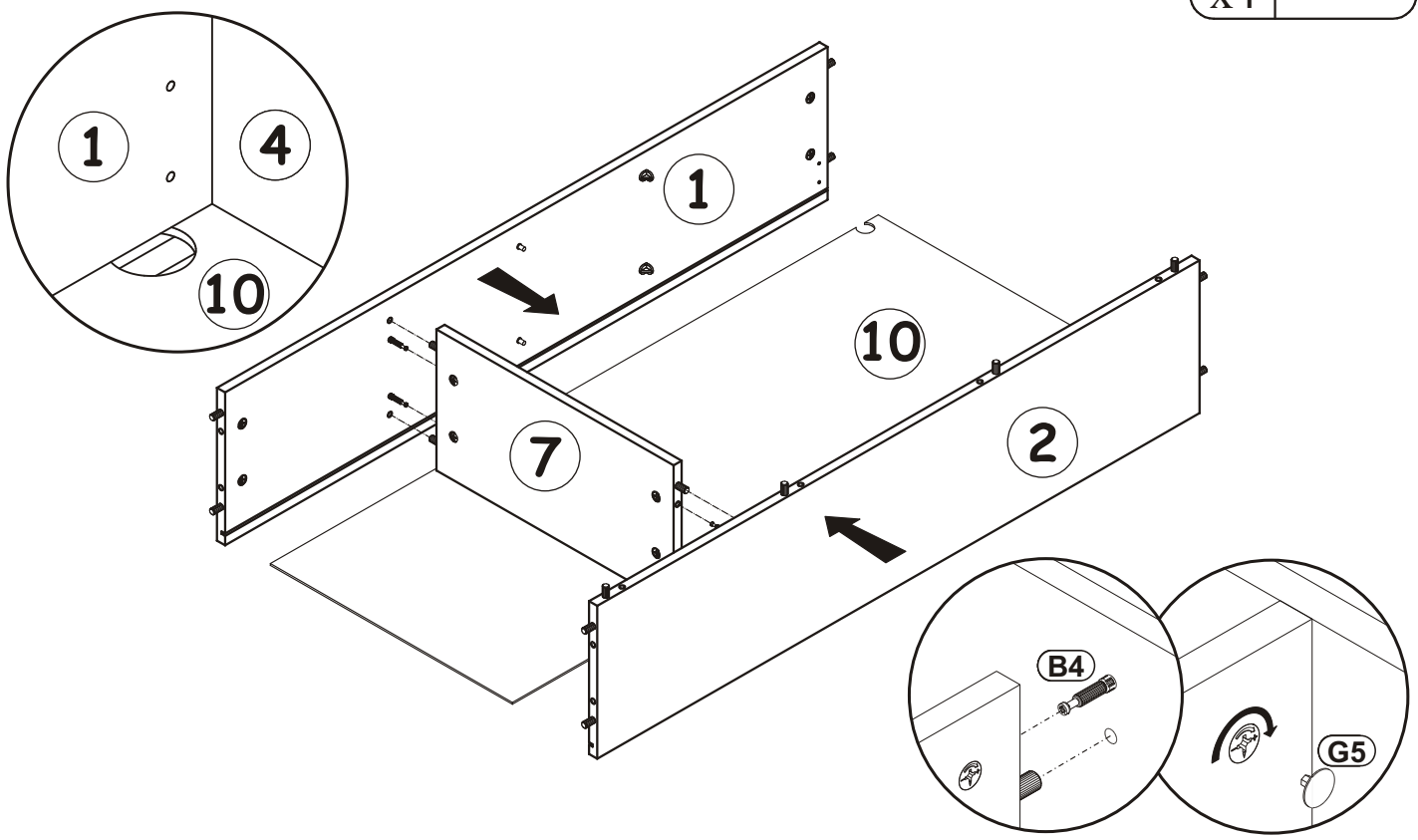

5

G5	
x12	

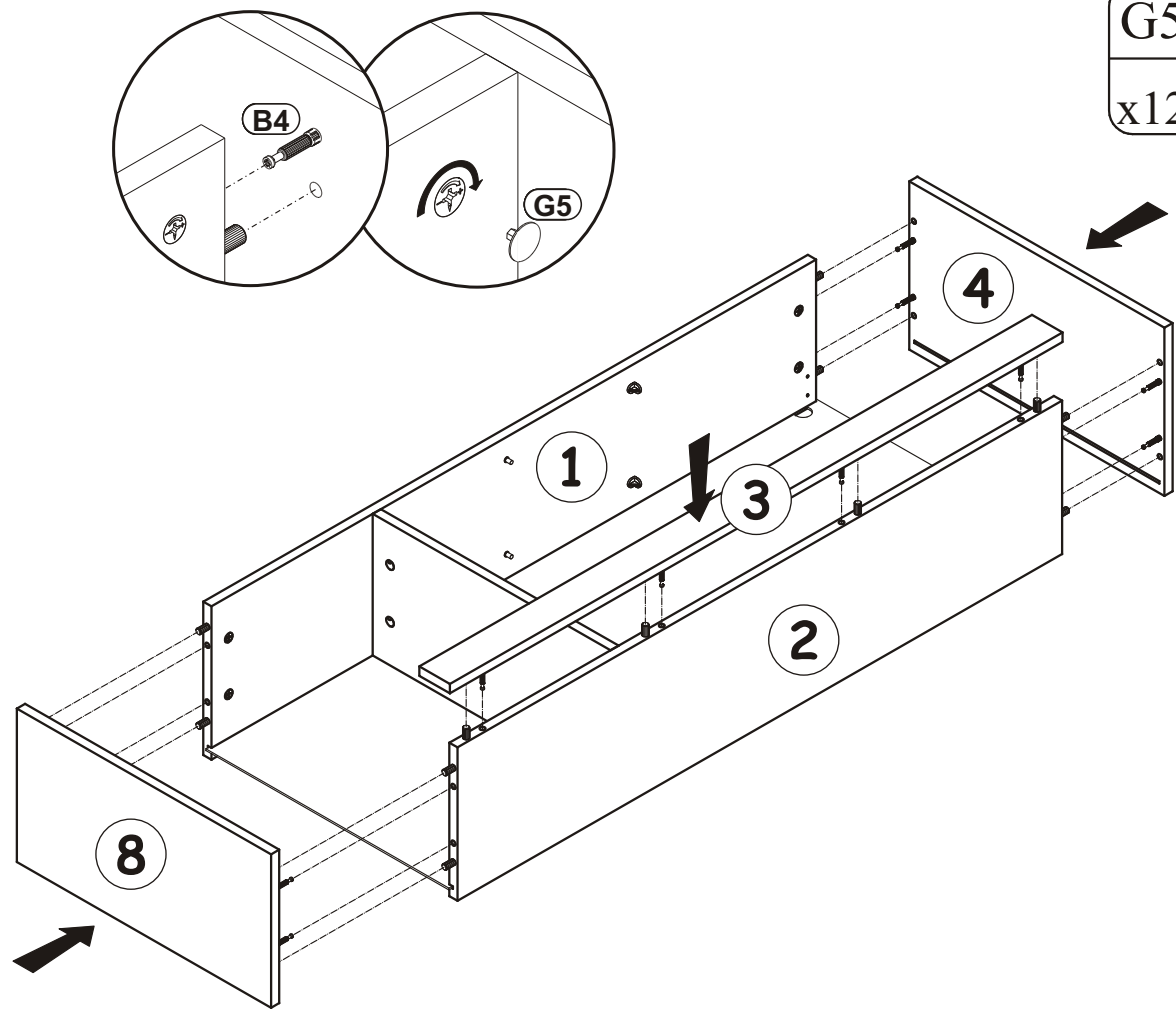

6

$X=Y$ 90°

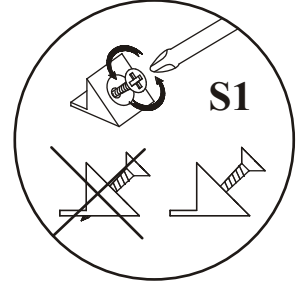
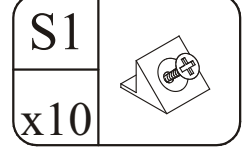
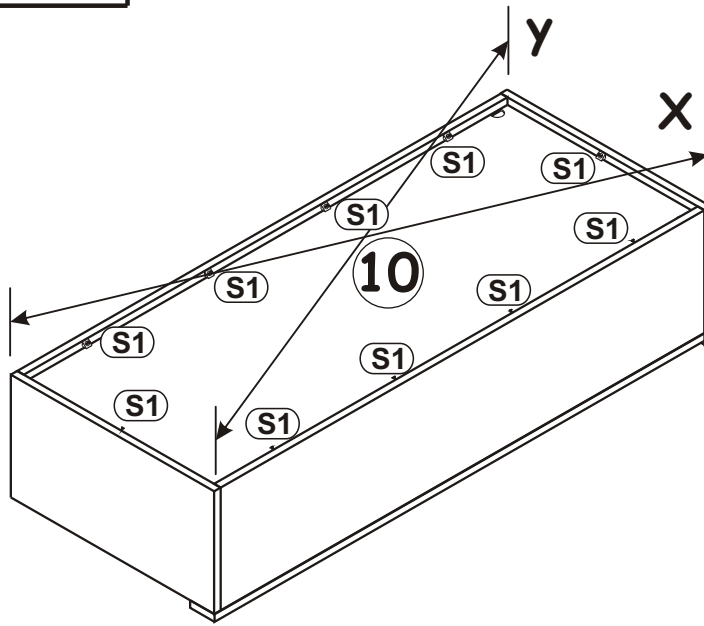

7

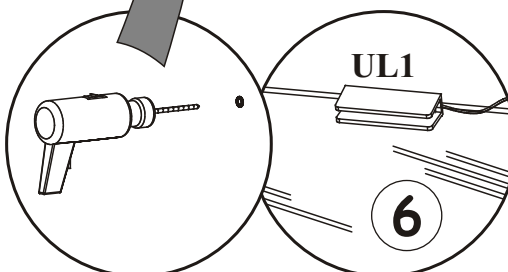
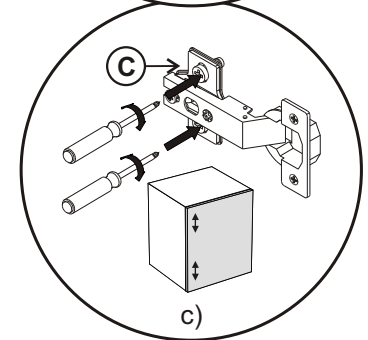
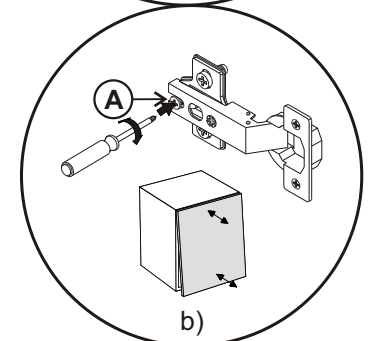
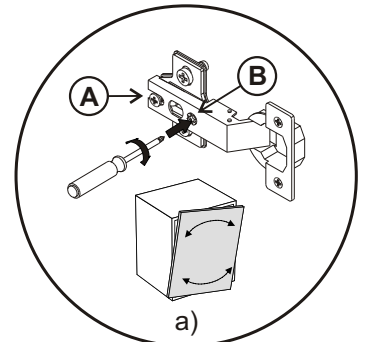
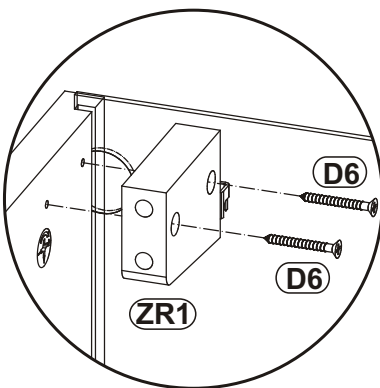
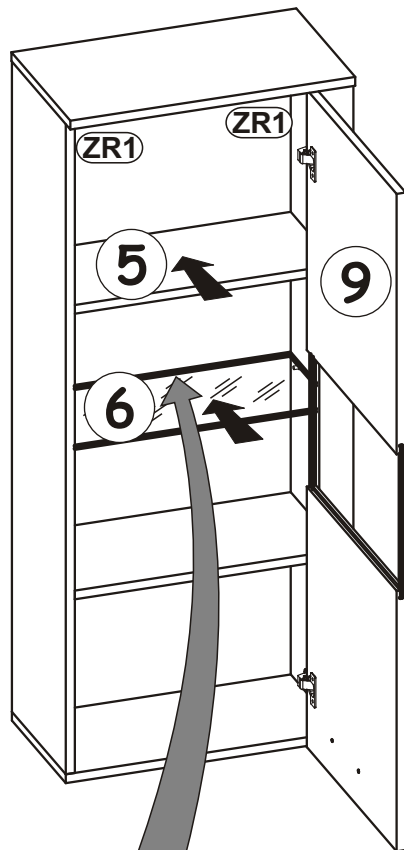
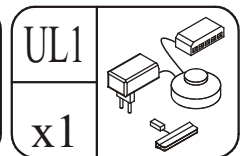
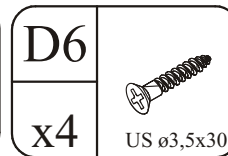
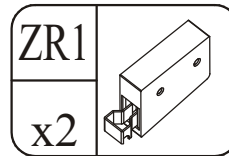

8

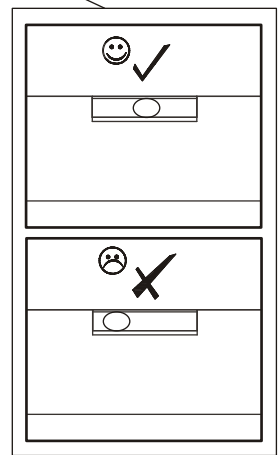
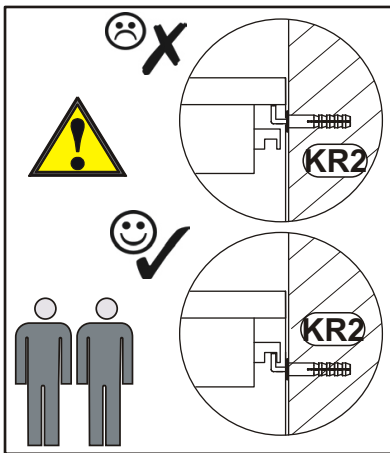
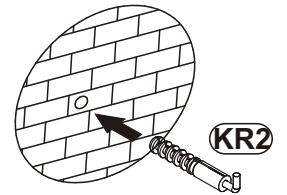
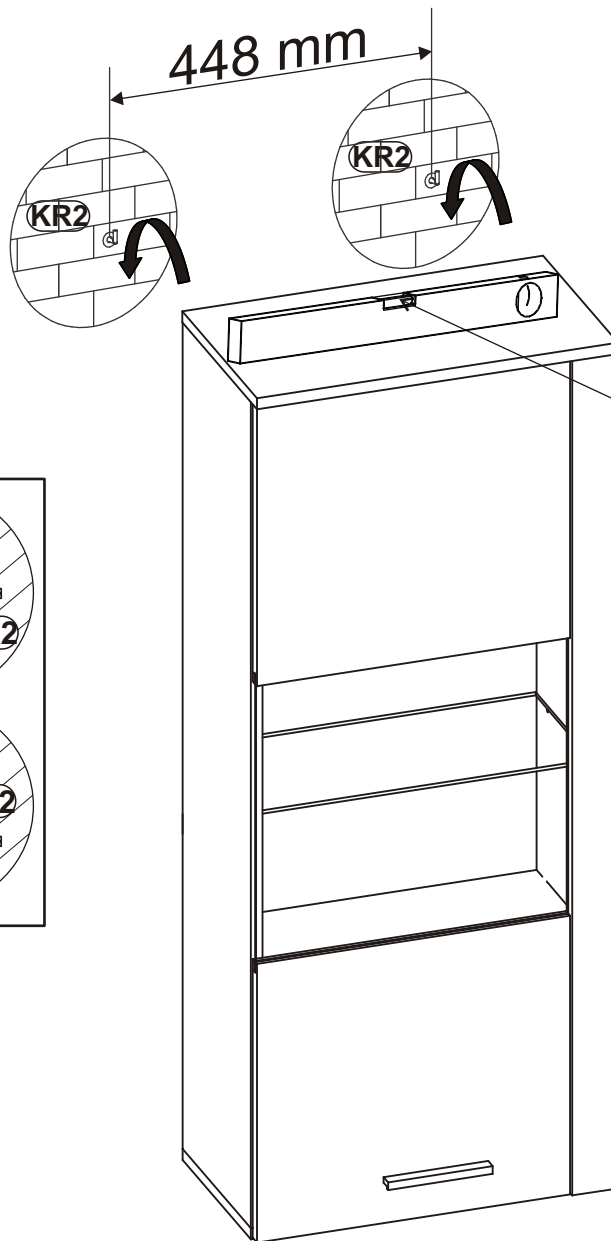
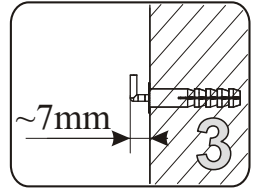
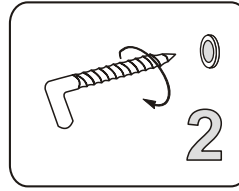
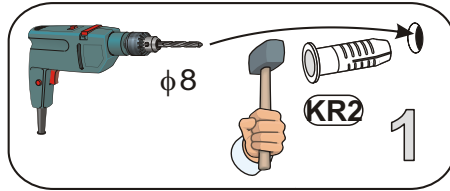
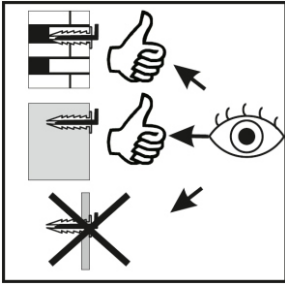
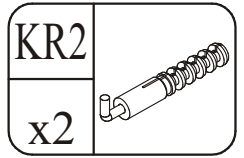

FRESH 28 -- FR-C-33

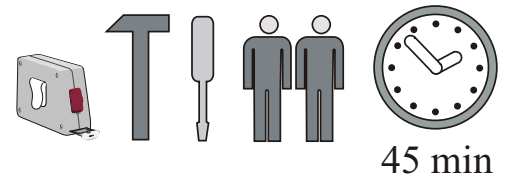
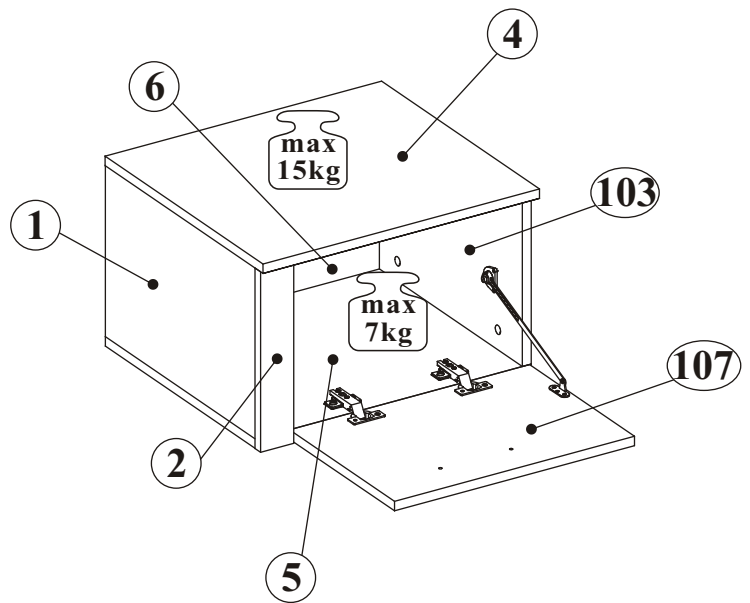
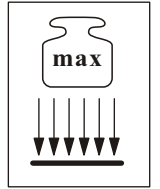
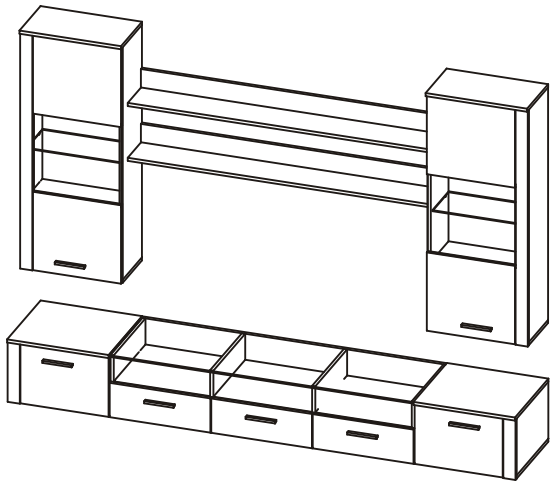



NO	Dim.		Col.-No	Qty
1	290	430	1	1
2	306	60	1	1
103	290	430	1	1
4	501	453	1	1
5	499	430	1	1
6	477	301	1	1
107	434	301	1	1

FRESH - 28 -- FR-C - 33

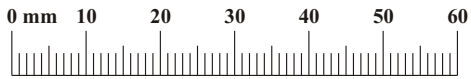
A1 x10 ø8x36	G2 x1	E1 x2 H=0	E2 x2 H=0	D10 x6 USØ3,5x13	I11 x4
B5 x10 ø15x12	B4 x10	G5 x10	UL2 x1	UP6 x2 øUP4x30	D11 x4 ø3,5x25
G21 x1	D7 x3 USØ3x16	S1 x4			

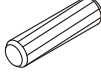

1

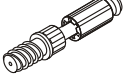
A1		B5		B4	
x10	ø8x36	x10	ø15x12	x2	

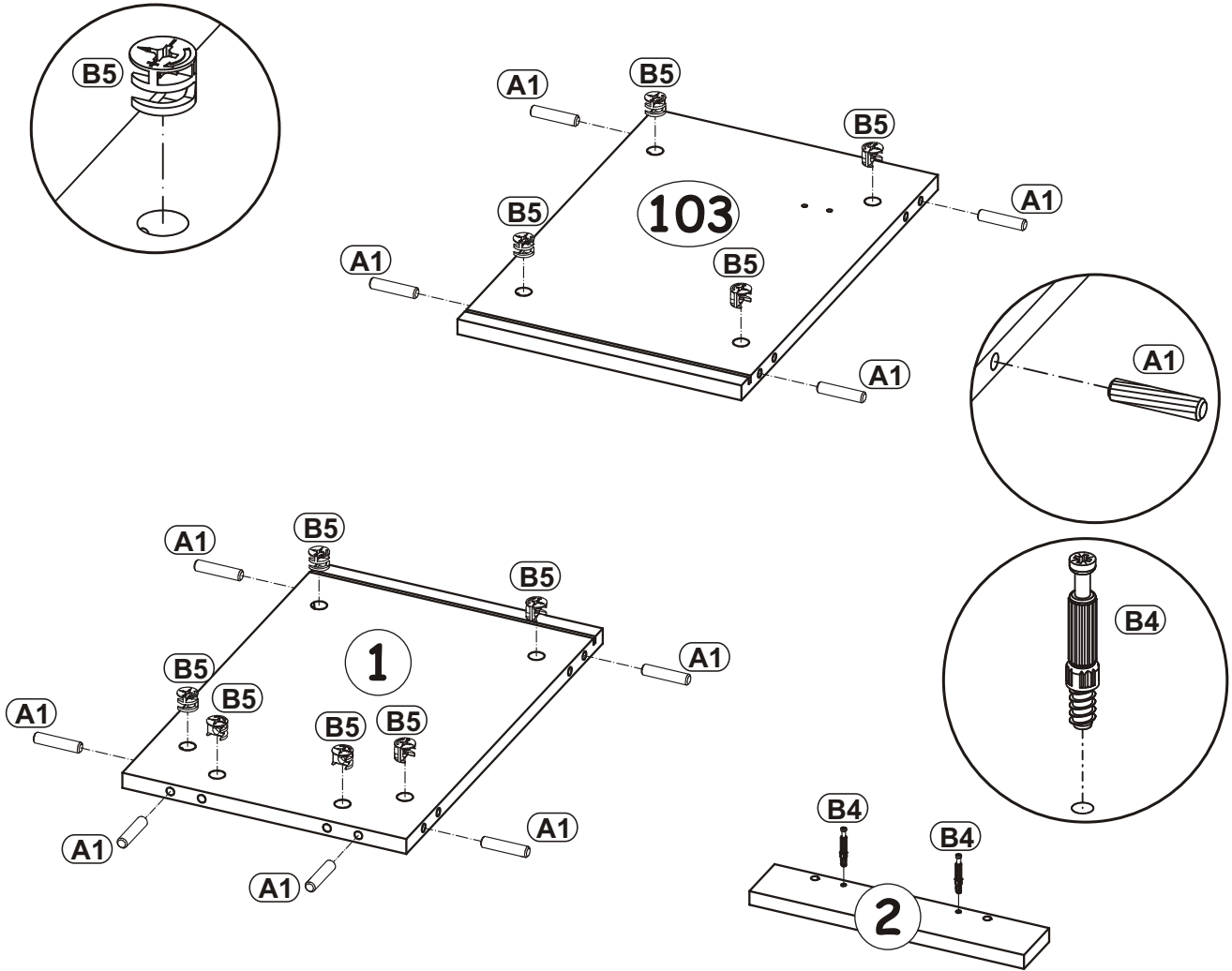

2

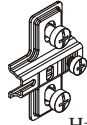
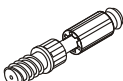
E2		B4	
x2	H=0	x8	

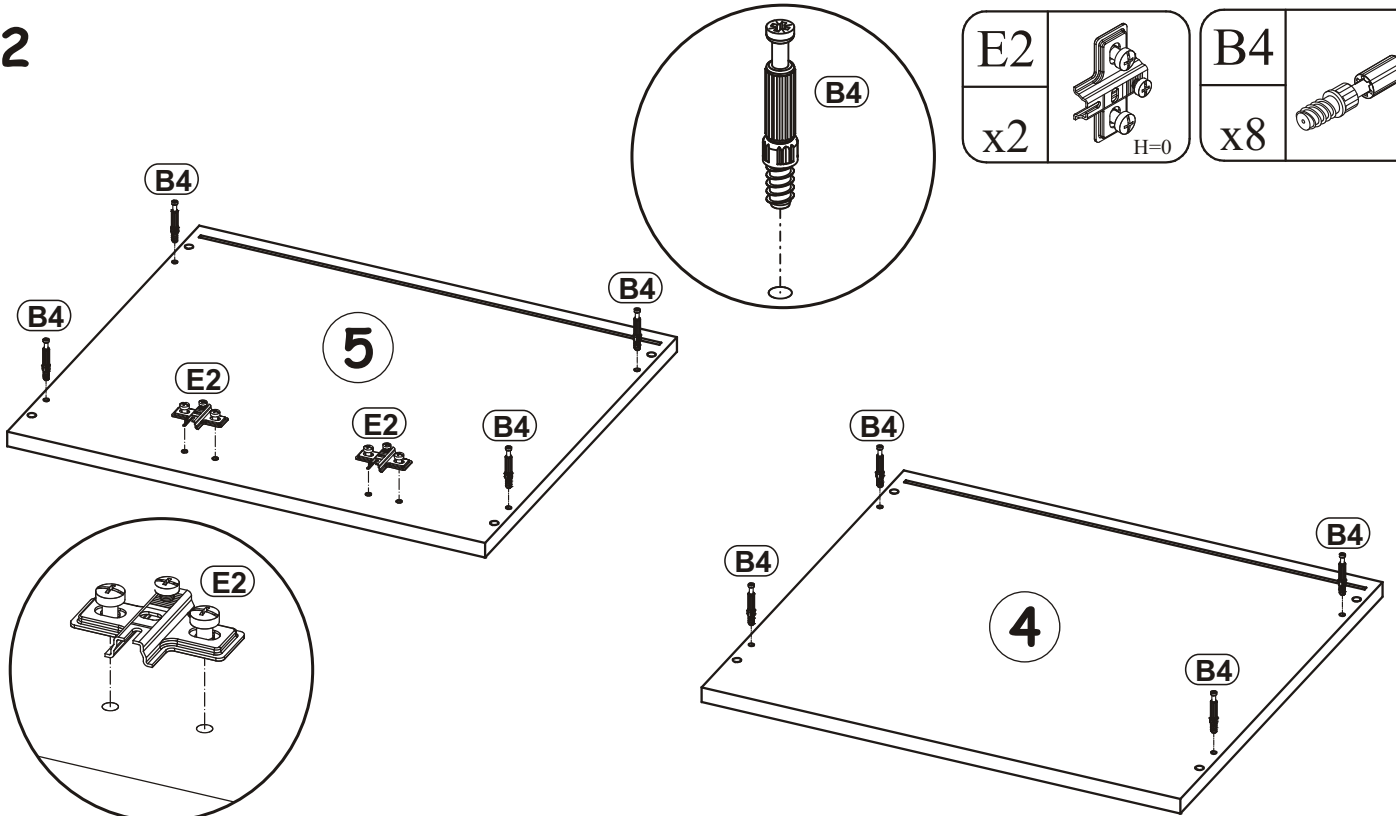

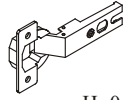
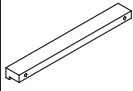
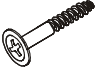

3

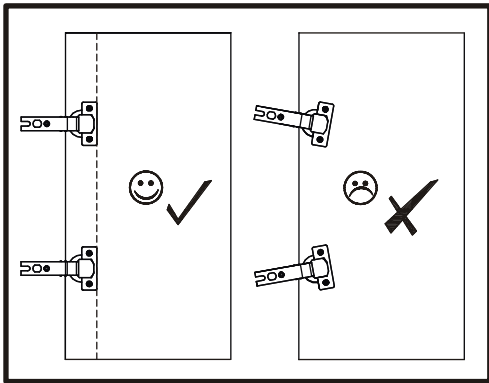
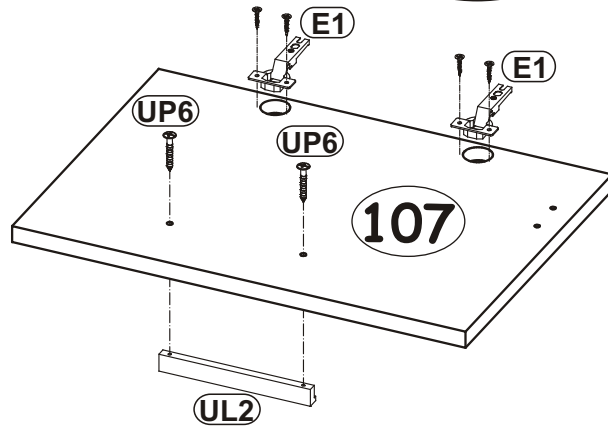
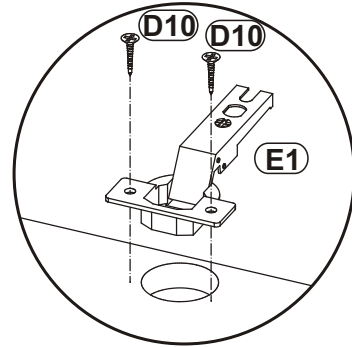
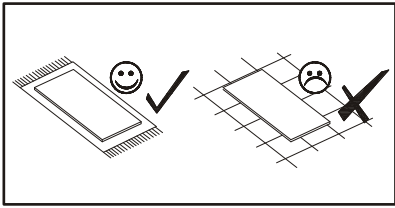
E1		UL2		UP6	
x2	H=0	x1		x2	øUP4x30



4

G5		I11		D11	
x8		x4		x4	ø3,5x25

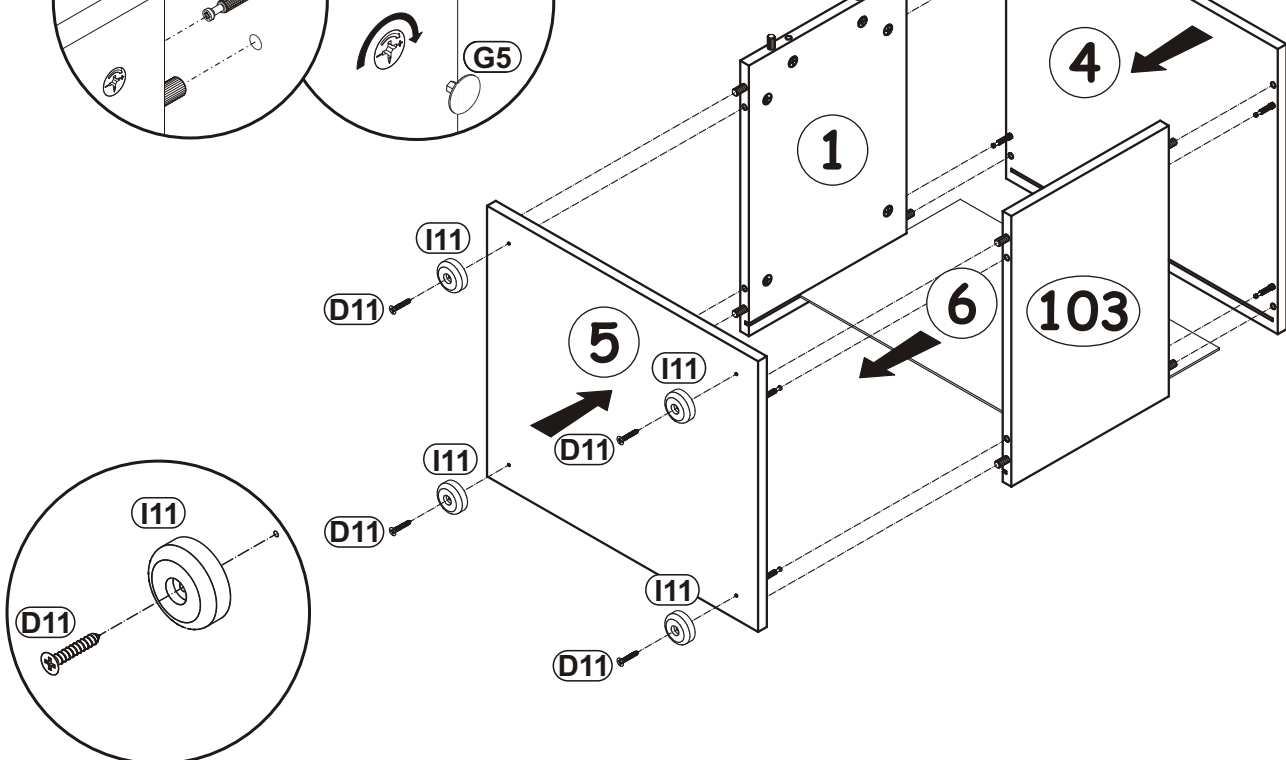
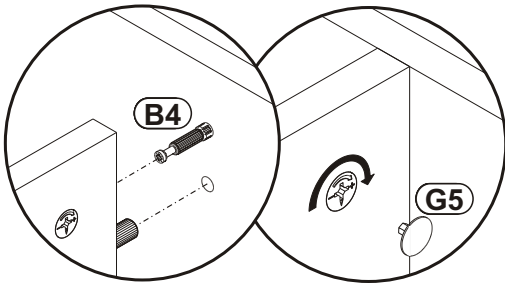

G5	
x2	

5

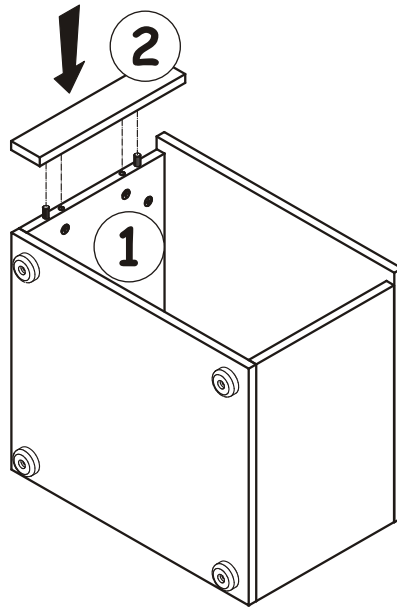
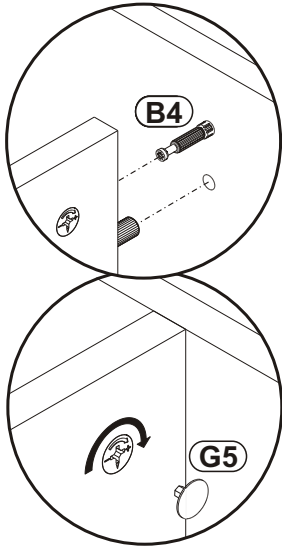

180°

6

S1	
x4	

$X=Y$ 

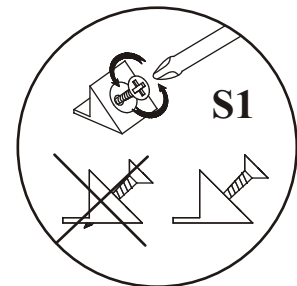
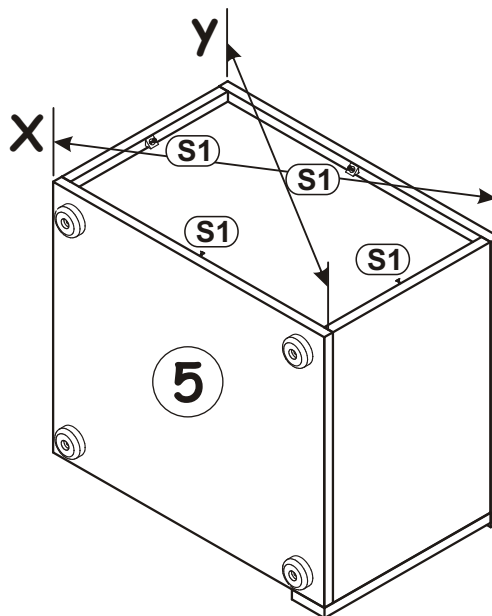

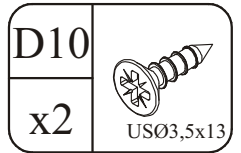
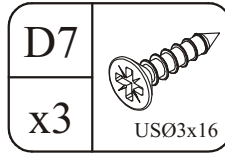
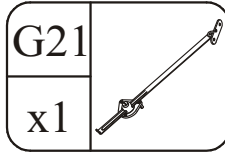

7

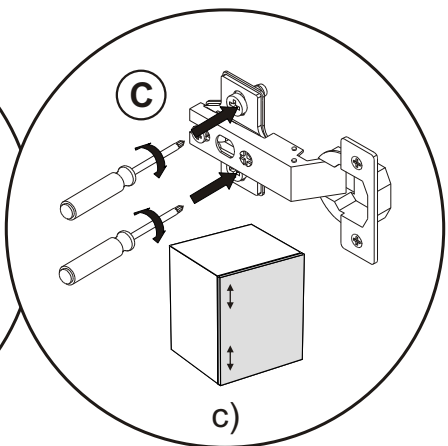
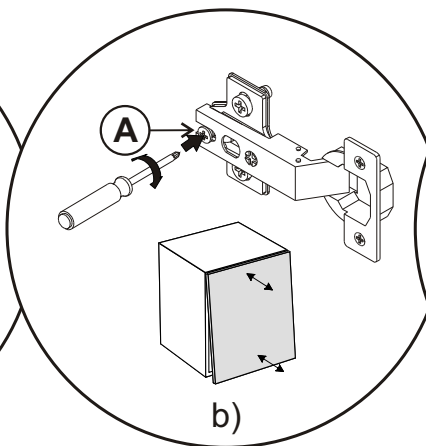
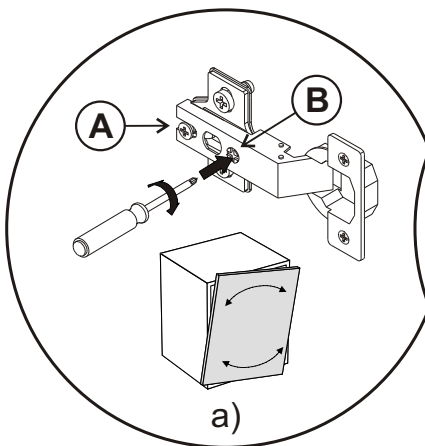
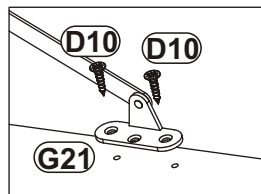
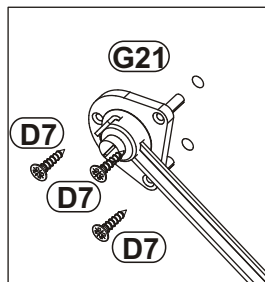
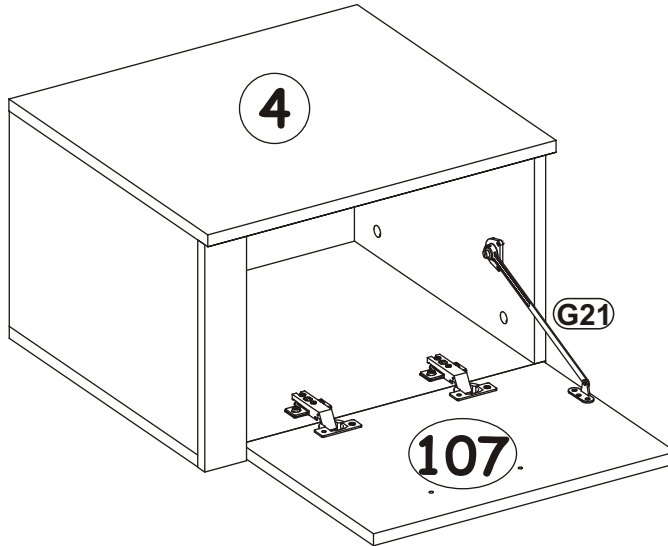

FRESH 28 -- FR-C-34

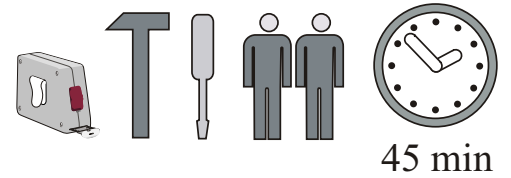
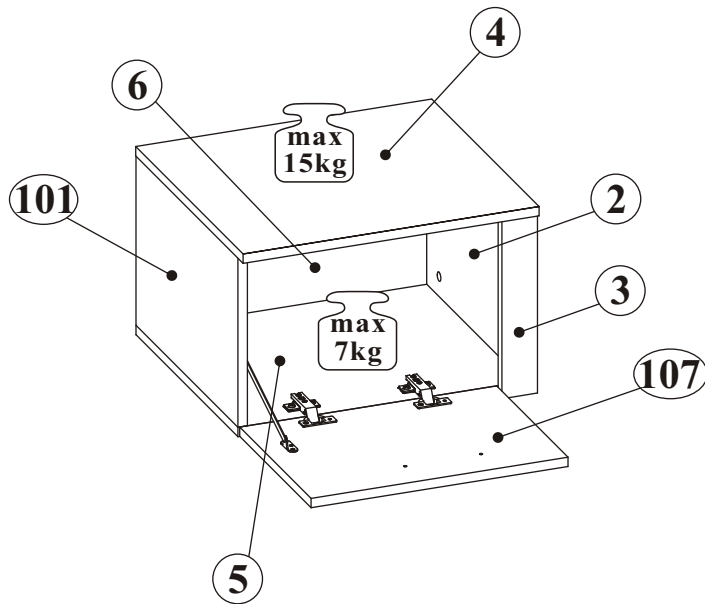
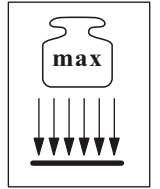
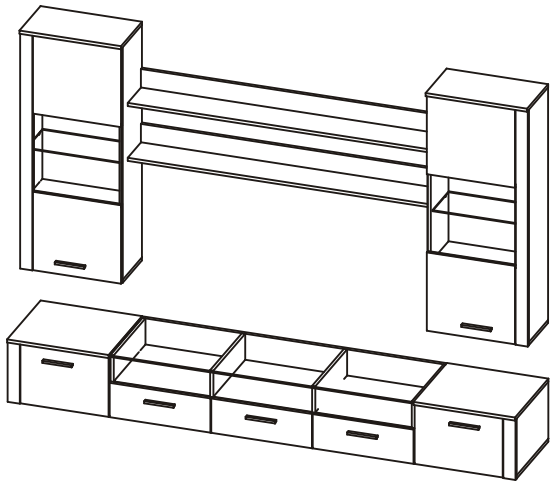

45 min



NO	Dim.		Col.-No	Qty
101	290	430	1	1
2	290	430	1	1
3	306	60	1	1
4	501	453	1	1
5	499	430	1	1
6	477	301	1	1
107	434	301	1	1

FRESH - 28 -- FR-C - 34

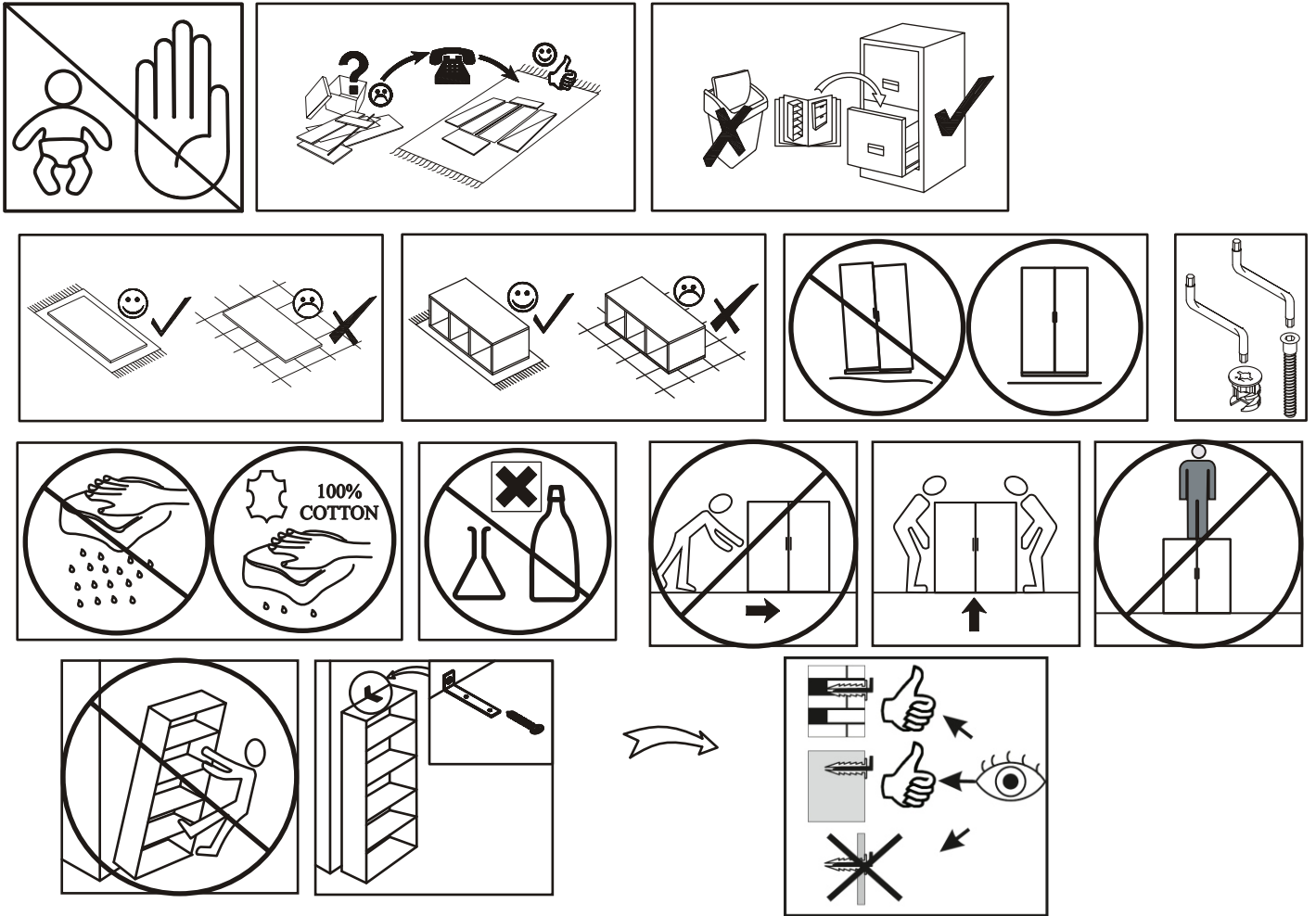
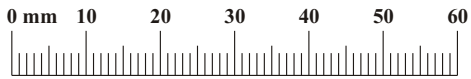
A1 x10 ø8x36	G2 x1	E1 x2 H=0	E2 x2 H=0	D10 x6 USØ3,5x13	I11 x4
B5 x10 ø15x12	B4 x10	G5 x10	UL2 x1	UP6 x2 øUP4x30	D11 x4 ø3,5x25
G21 x1	D7 x3 USØ3x16	S1 x4			

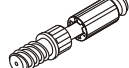

1

A1		B5		B4	
x10	ø8x36	x10	ø1.5x12	x2	

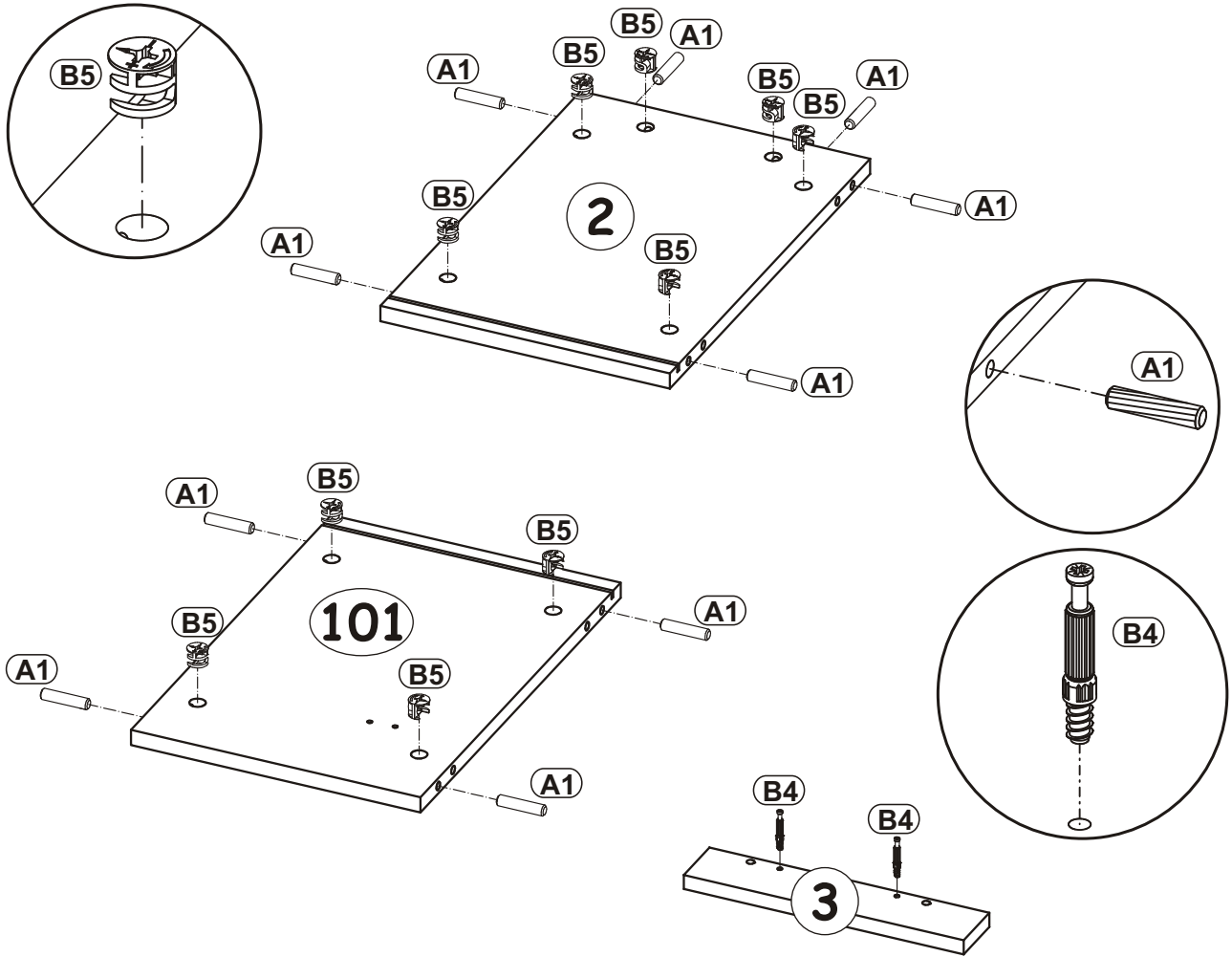

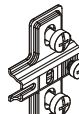
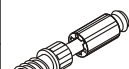

2

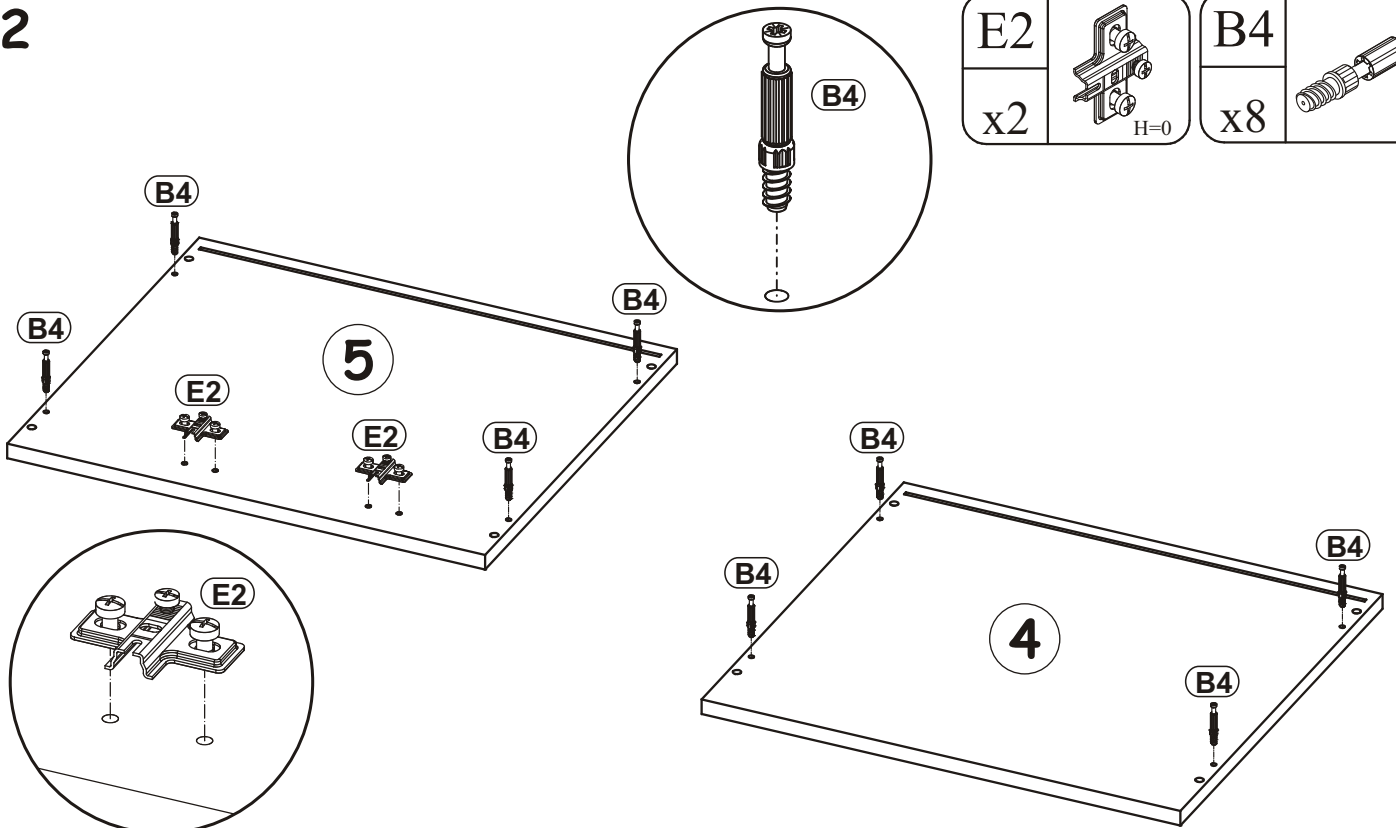
E2		B4	
x2	H=0	x8	



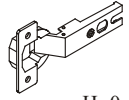
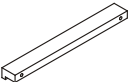

3

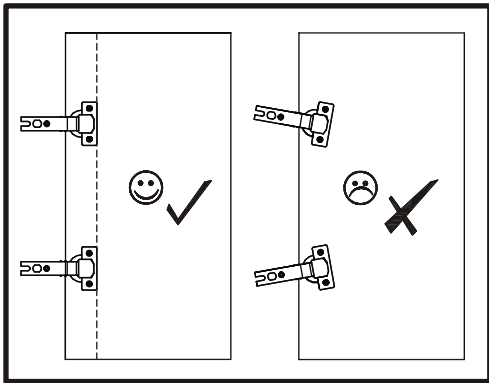
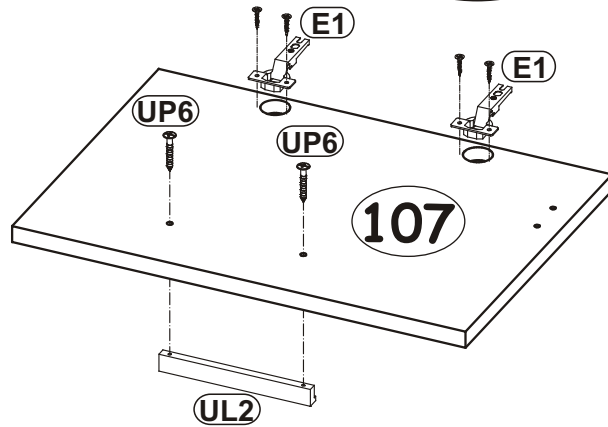
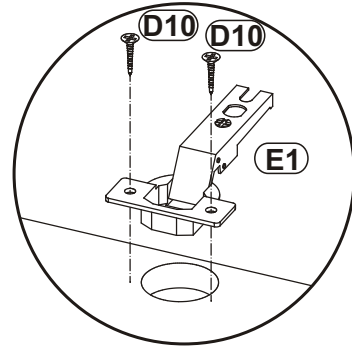
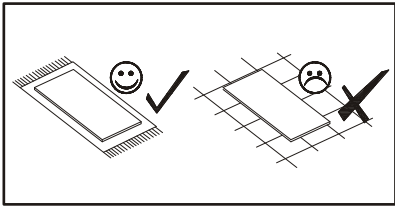
E1		UL2		UP6	
x2	H=0	x1		x2	øUP4x30

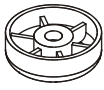

4

G5		I11		D11	
x8		x4		x4	ø3,5x25

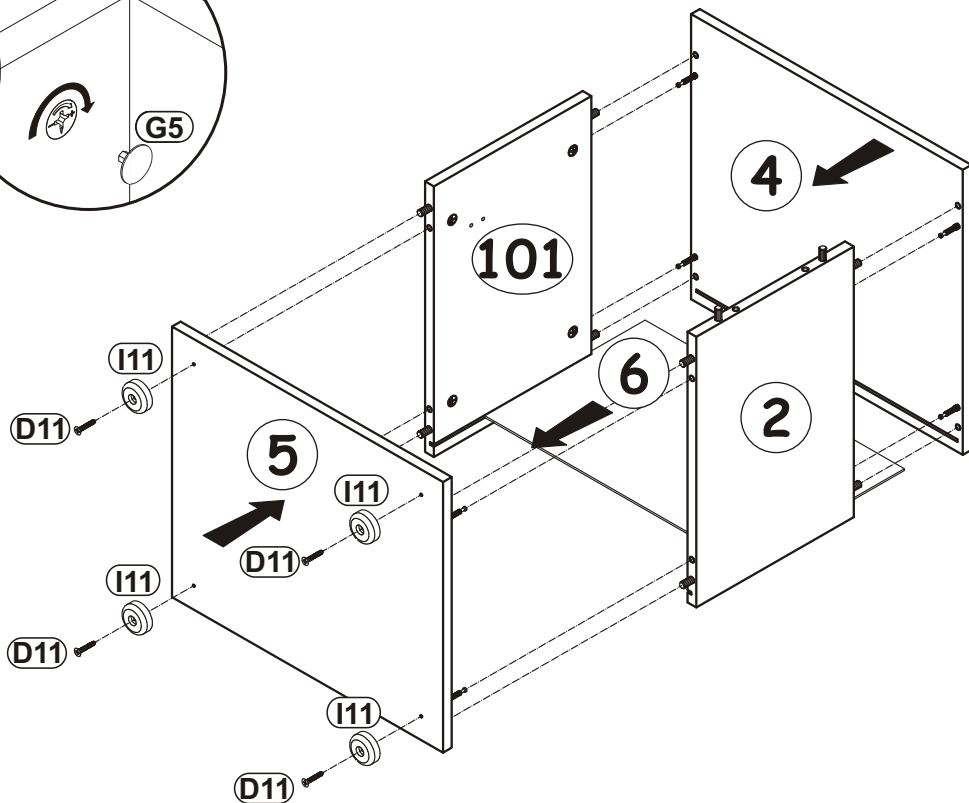
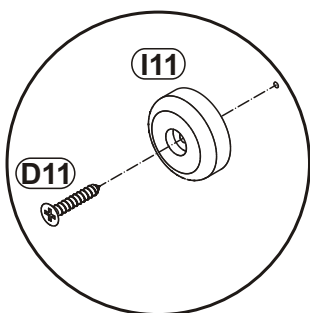
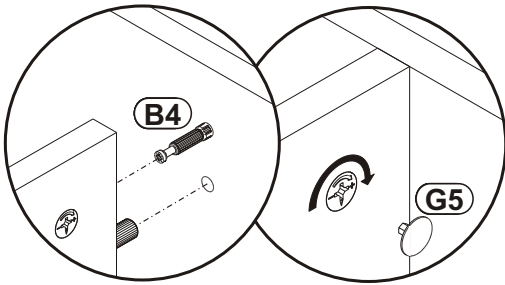

G5	
x2	

5

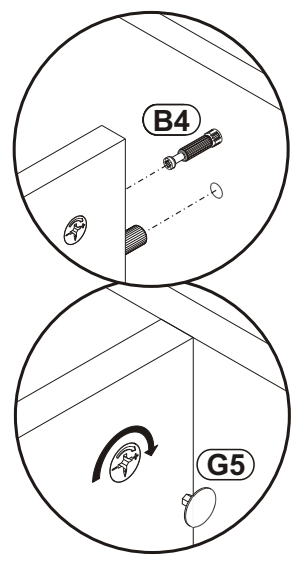
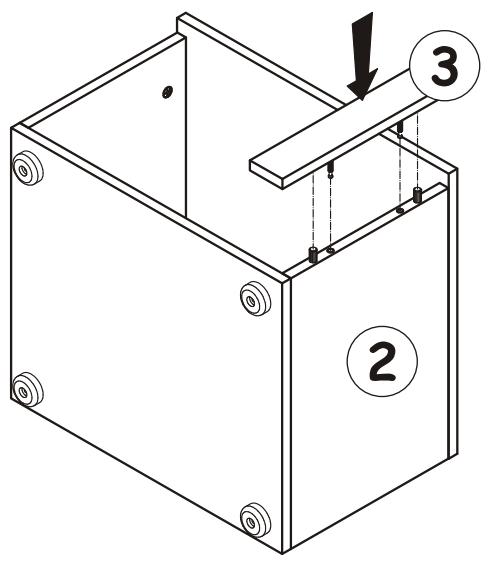

180°

6

S1	
x4	

X=Y 

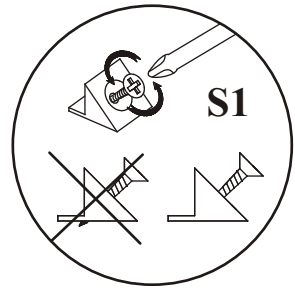
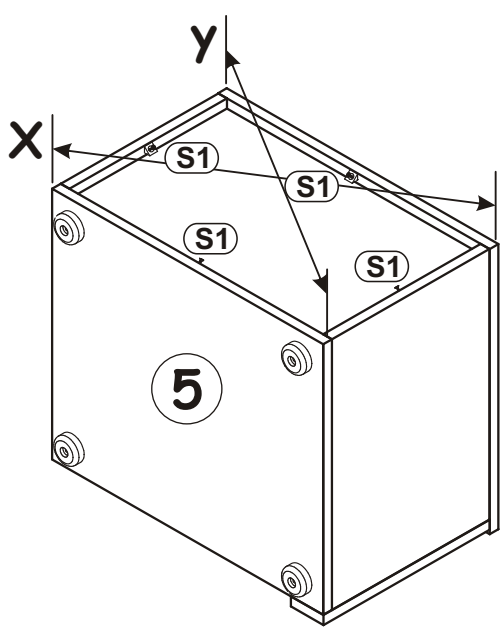

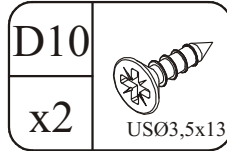
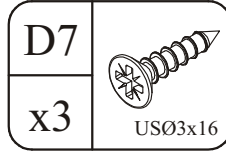
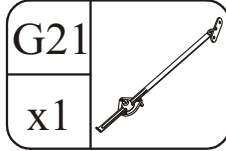

7

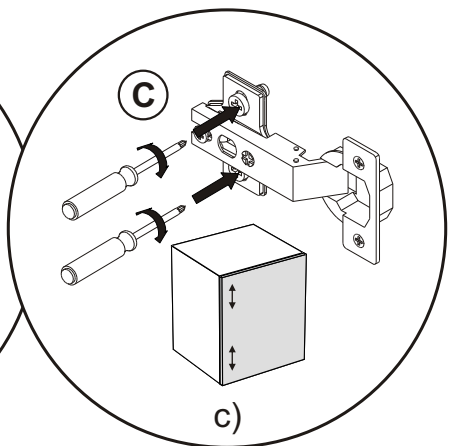
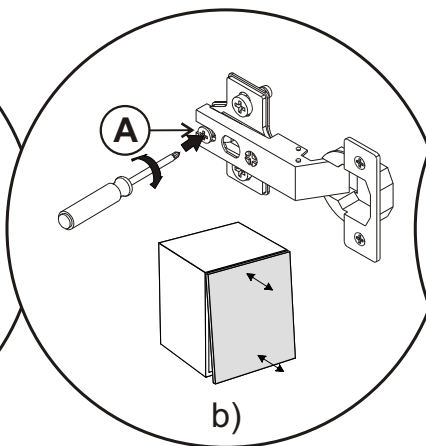
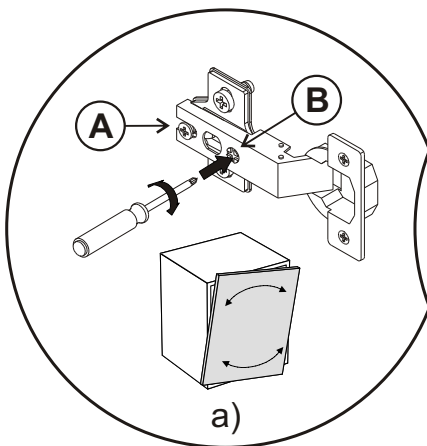
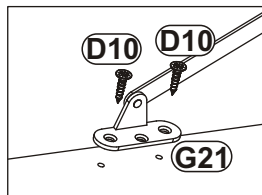
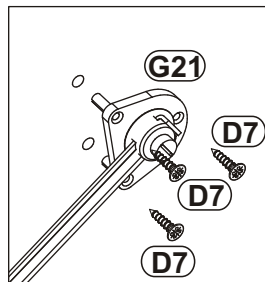
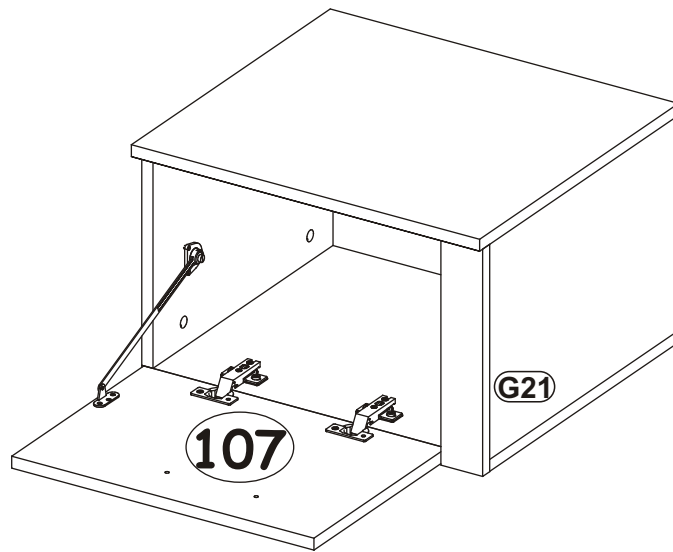

FRESH 28 -- FR-C-35

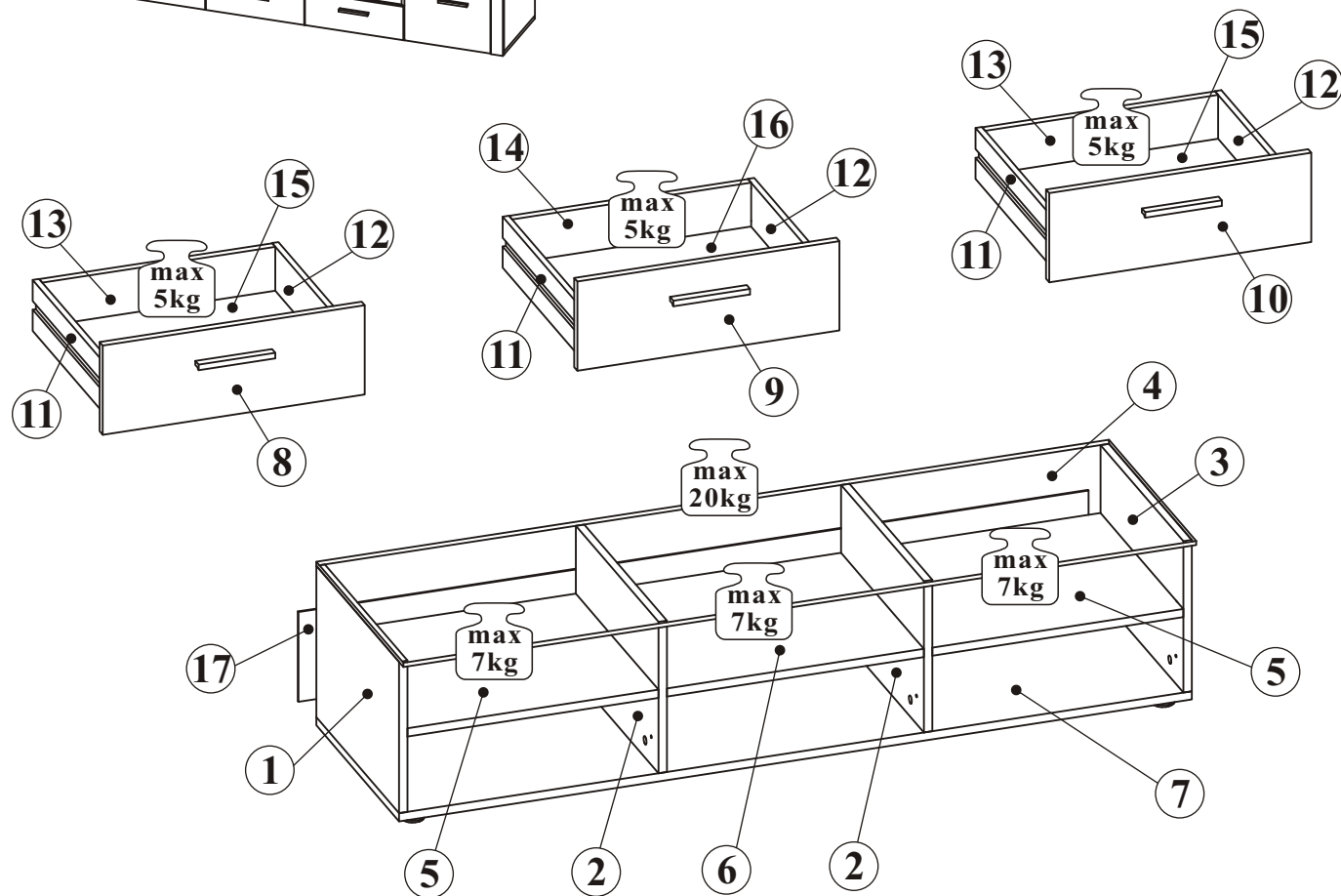
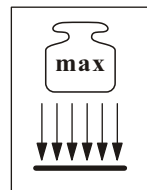
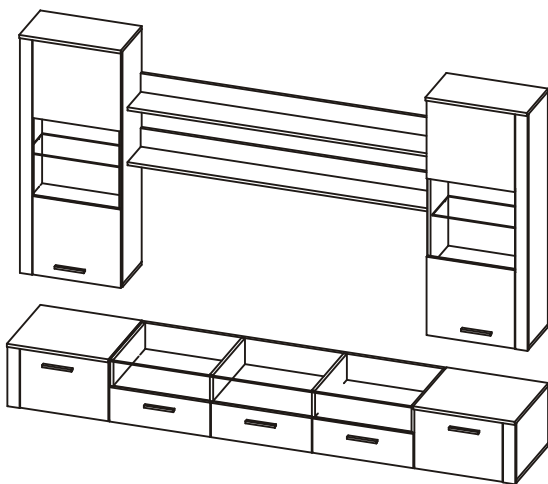

NO	Dim.		Col.-No	Qty
1	297	430	1	1
2	297	430	1	2
3	297	430	1	1
4	1498	453	1	1
5	475	430	1	2
6	485	430	1	1
7	1500	430	1	1
8	496	175	1	1
9	496	175	1	1
10	496	175	1	1
11	400	100	1	3
12	400	100	1	3
13	442	85	1	2
14	452	85	1	1
15	453	405	1	2
16	463	405	1	1
17	1495	176	1	1

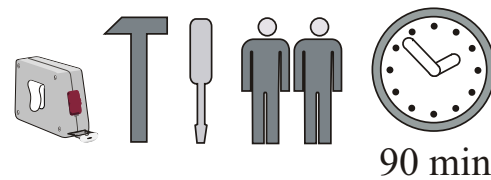

90 min

FRESH - 28 -- FR-C - 35

A1 x44 ø8x36	G2 x1	H6 x3 L-400	D18 x6 M4x9	D20 x12 øES6x8	I11 x6
B5 x20 ø15x12	B4 x12	B6 x4 ø7x76	G5 x20	UL2 x3	UP6 x6 øUP4x30
UL1 x1	Z5 x16	G1 x2 Klej	B3 x49 ø1,4x25	D11 x6 ø3,5x25	

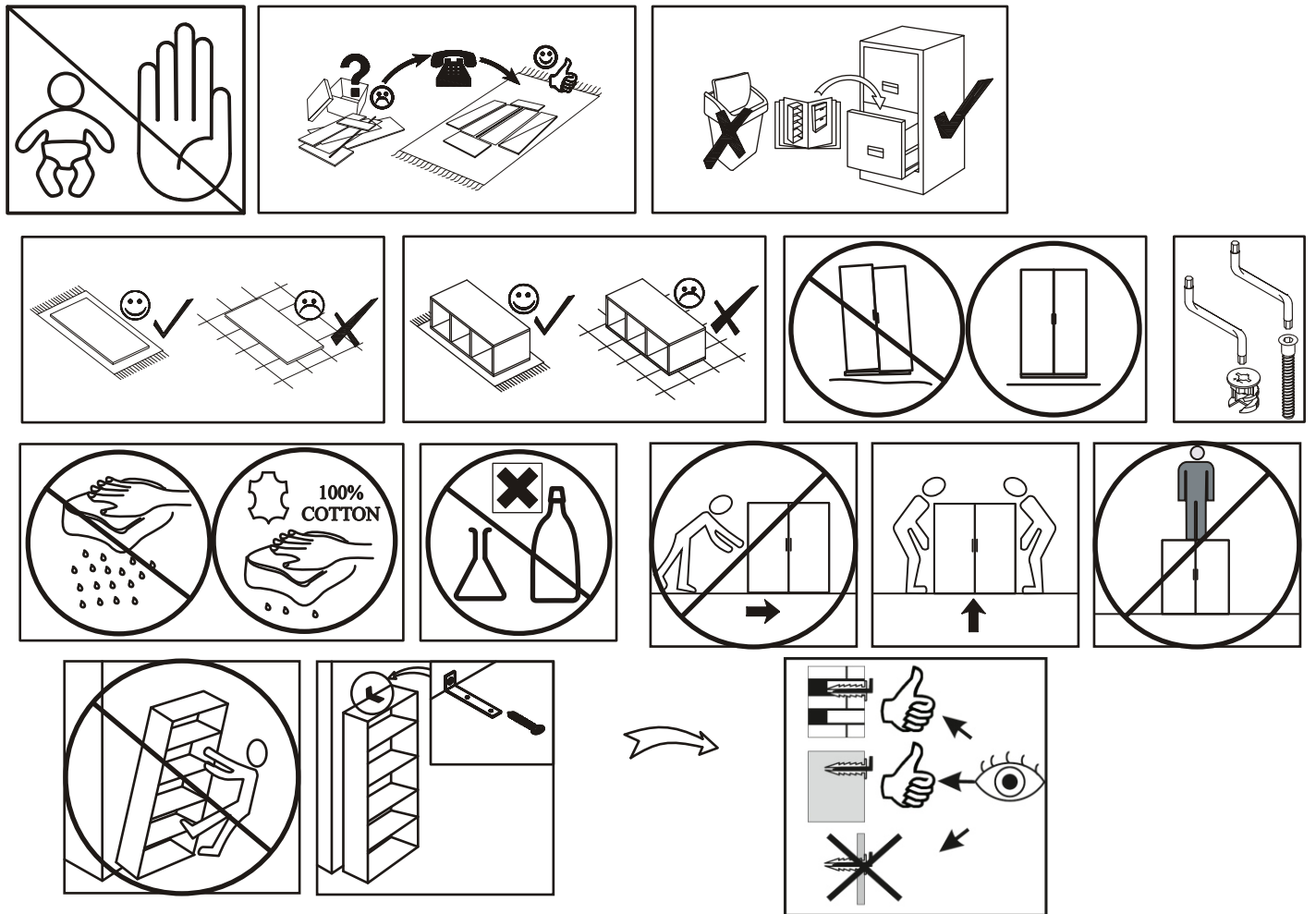
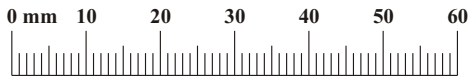

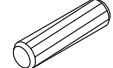

1

A1	
x8	ø8x36

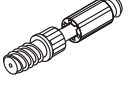
B5	
x8	ø15x12



B4	
x4	

H6	
x3	L-400

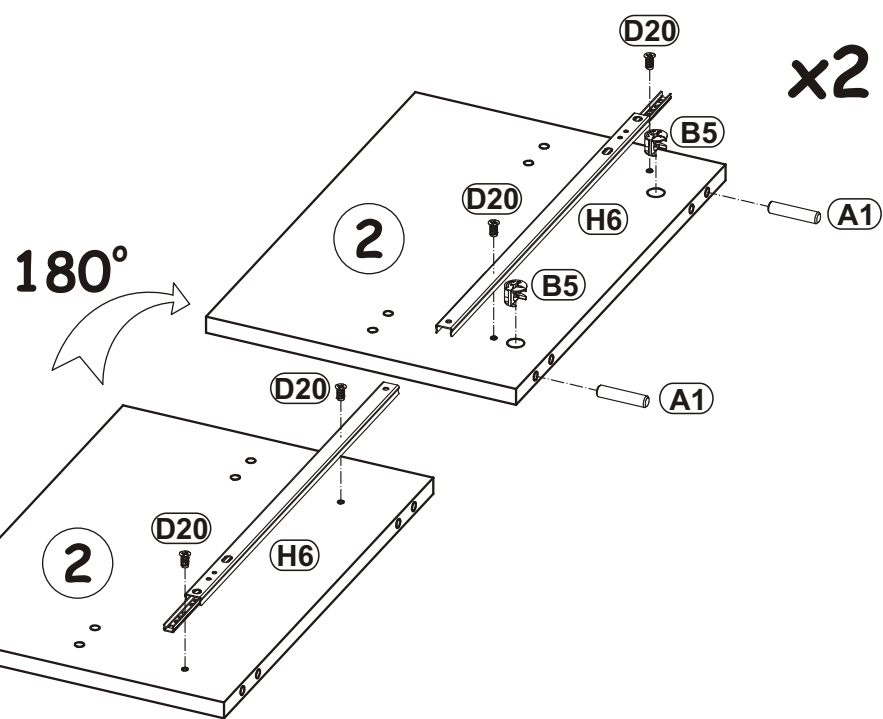
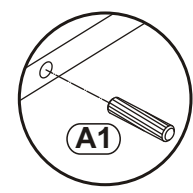
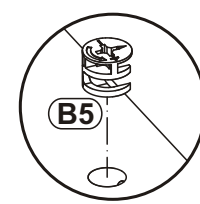
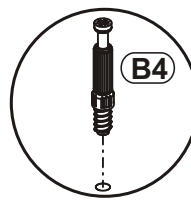
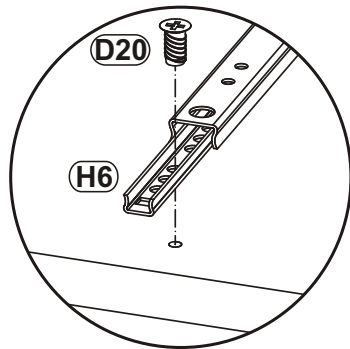
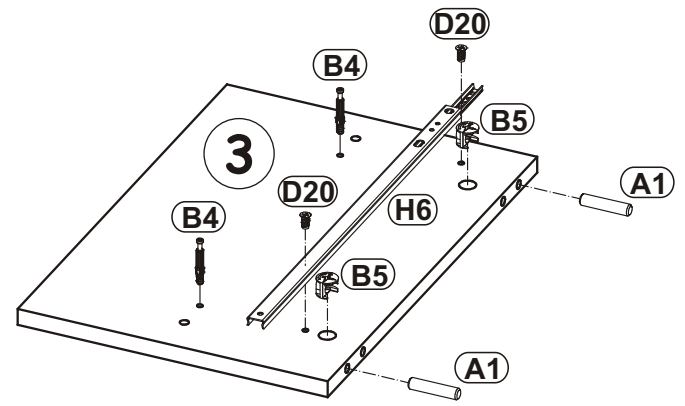
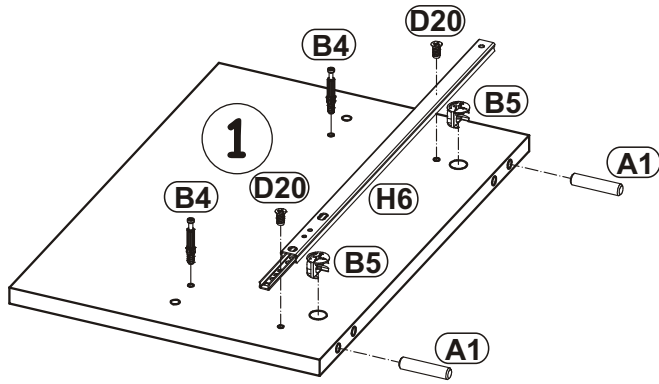
D20	
x12	øES6x8



2

A1		B5	
x12	ø8x36	x12	ø15x12

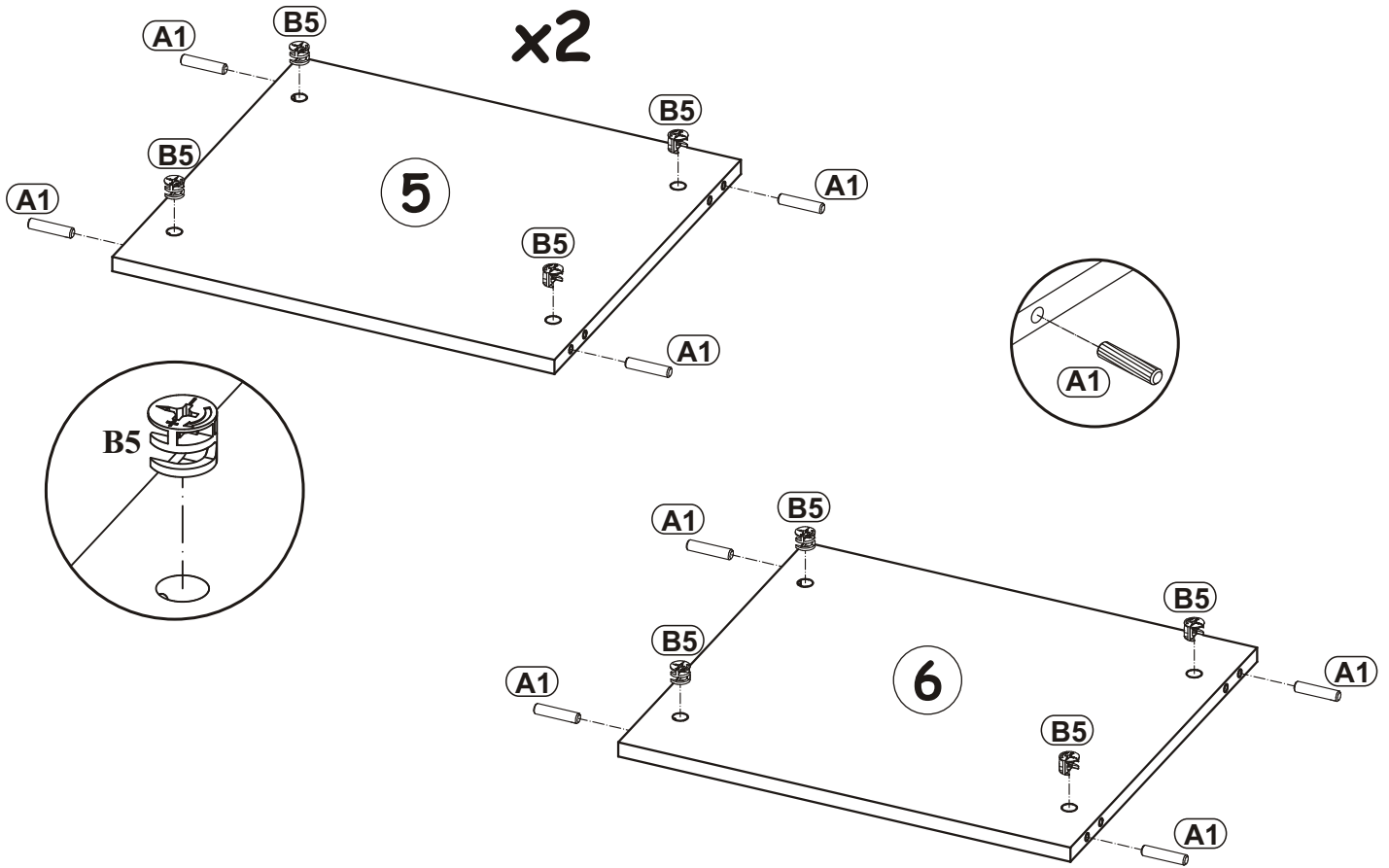

3

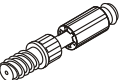
B4	
x8	

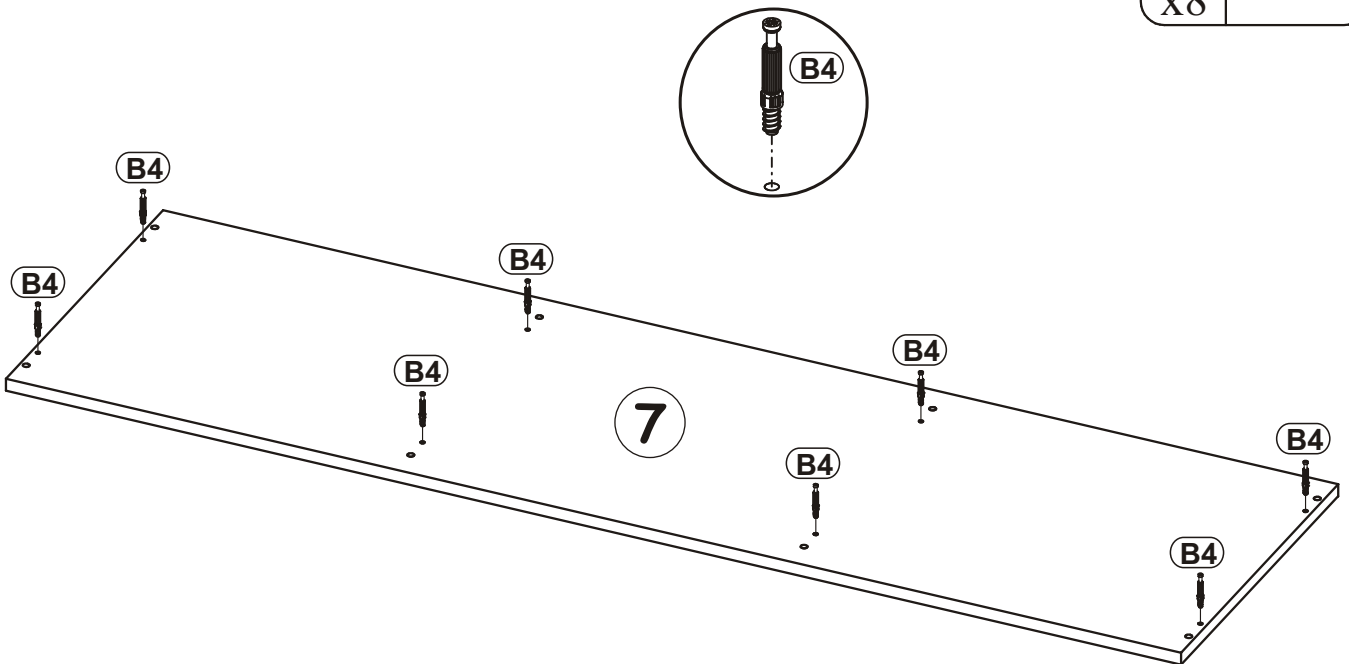

4

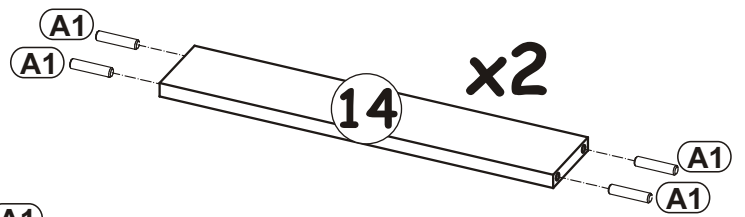
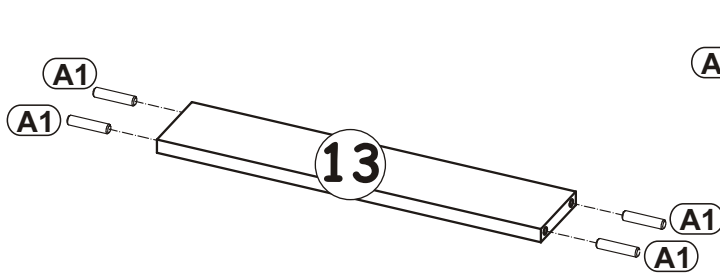
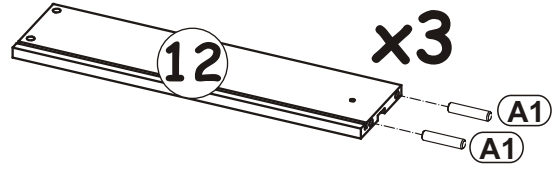
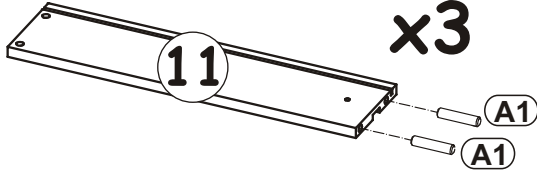
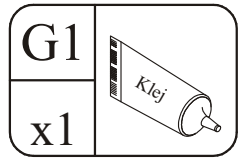
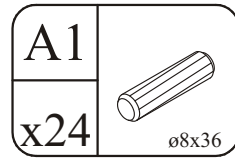
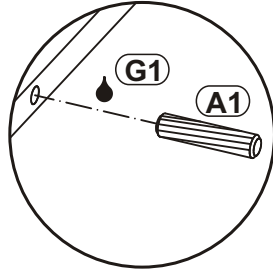

5

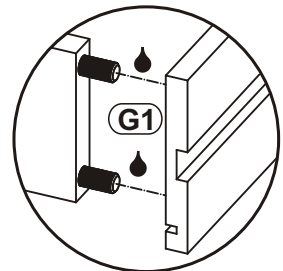
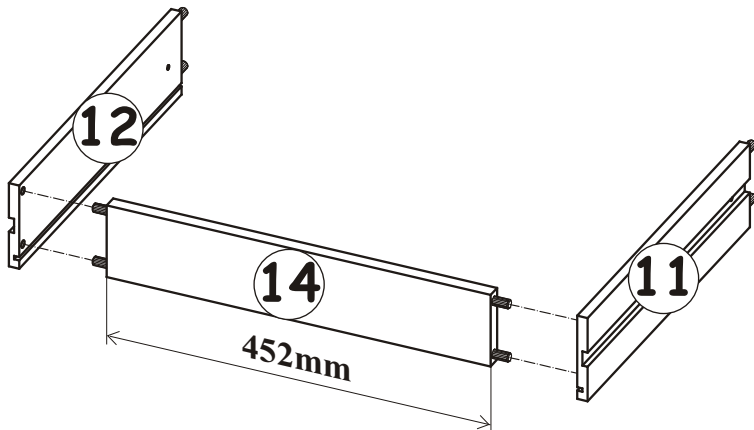
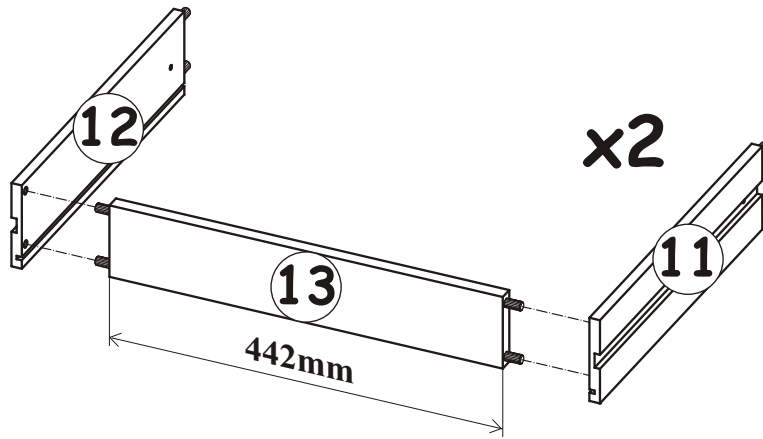
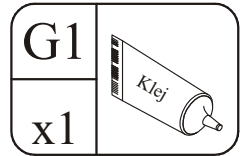

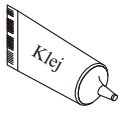
G1	
x1	

6

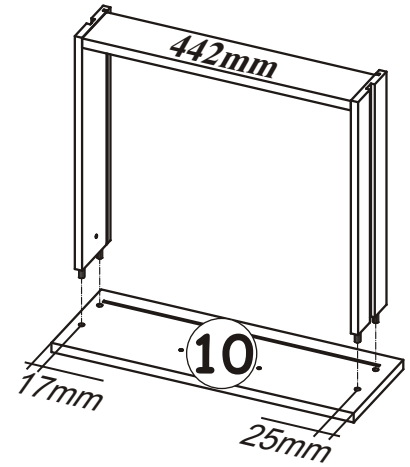
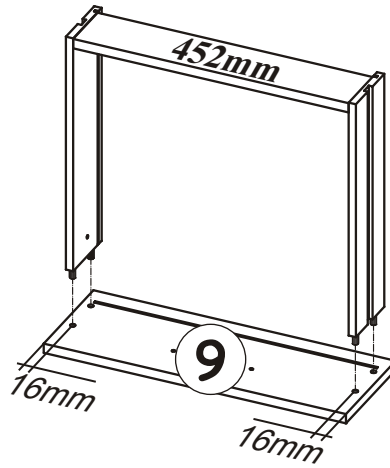
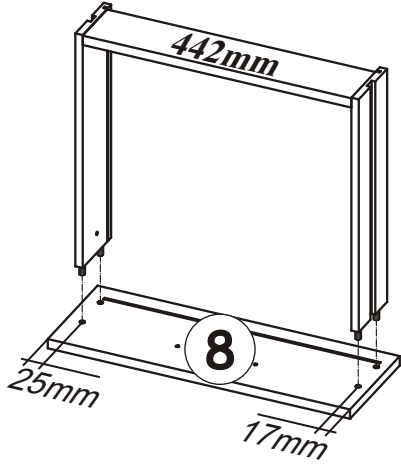
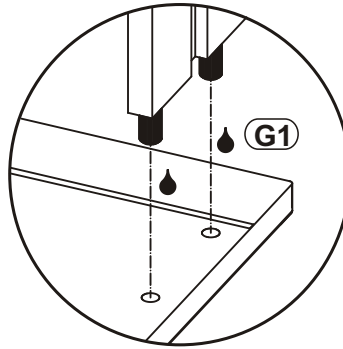
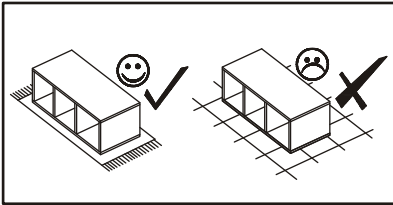

7

$X=Y$ 90°

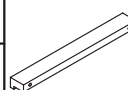

UL2	
x3	

UP6	
x6	$\phi UP4x30$

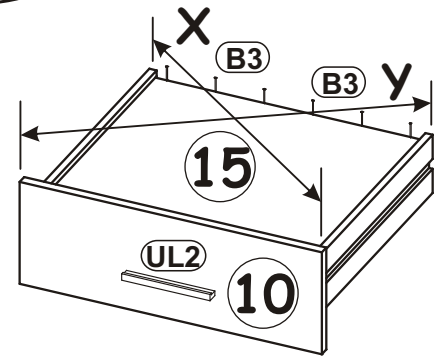
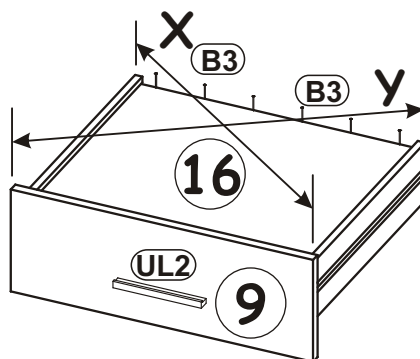
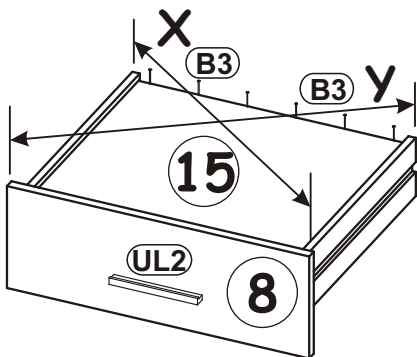
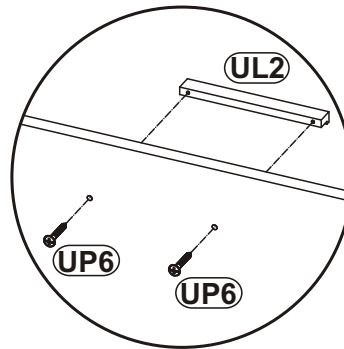
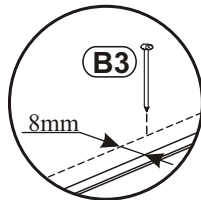
B3	
x18	$\phi 1,4x25$

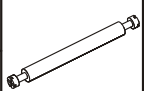

8

B6		G5	
x4	ø7x76	x4	

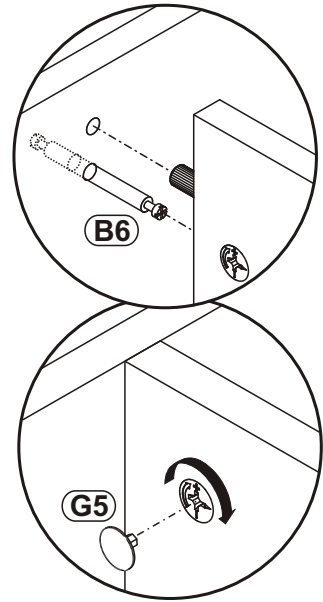
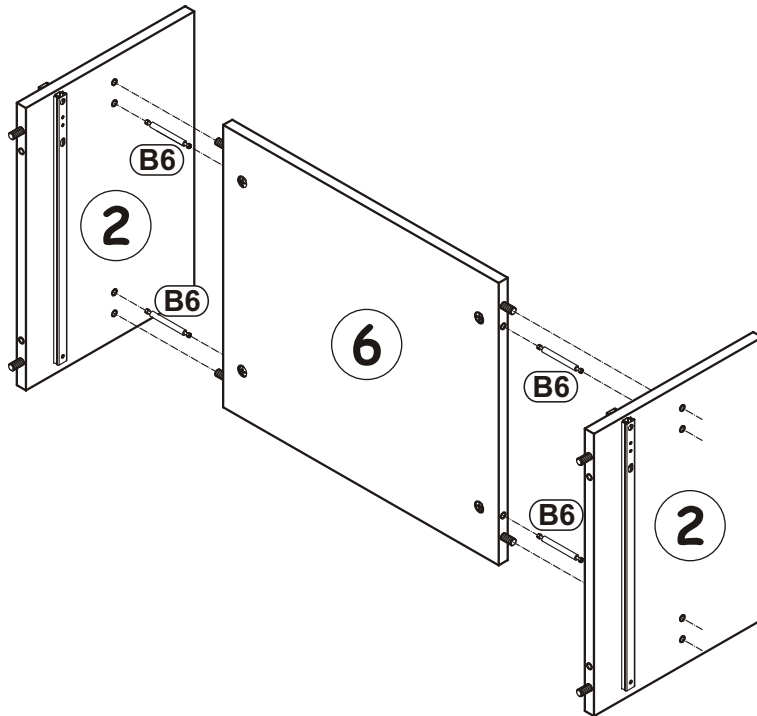

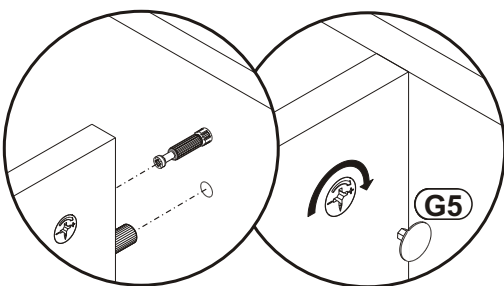
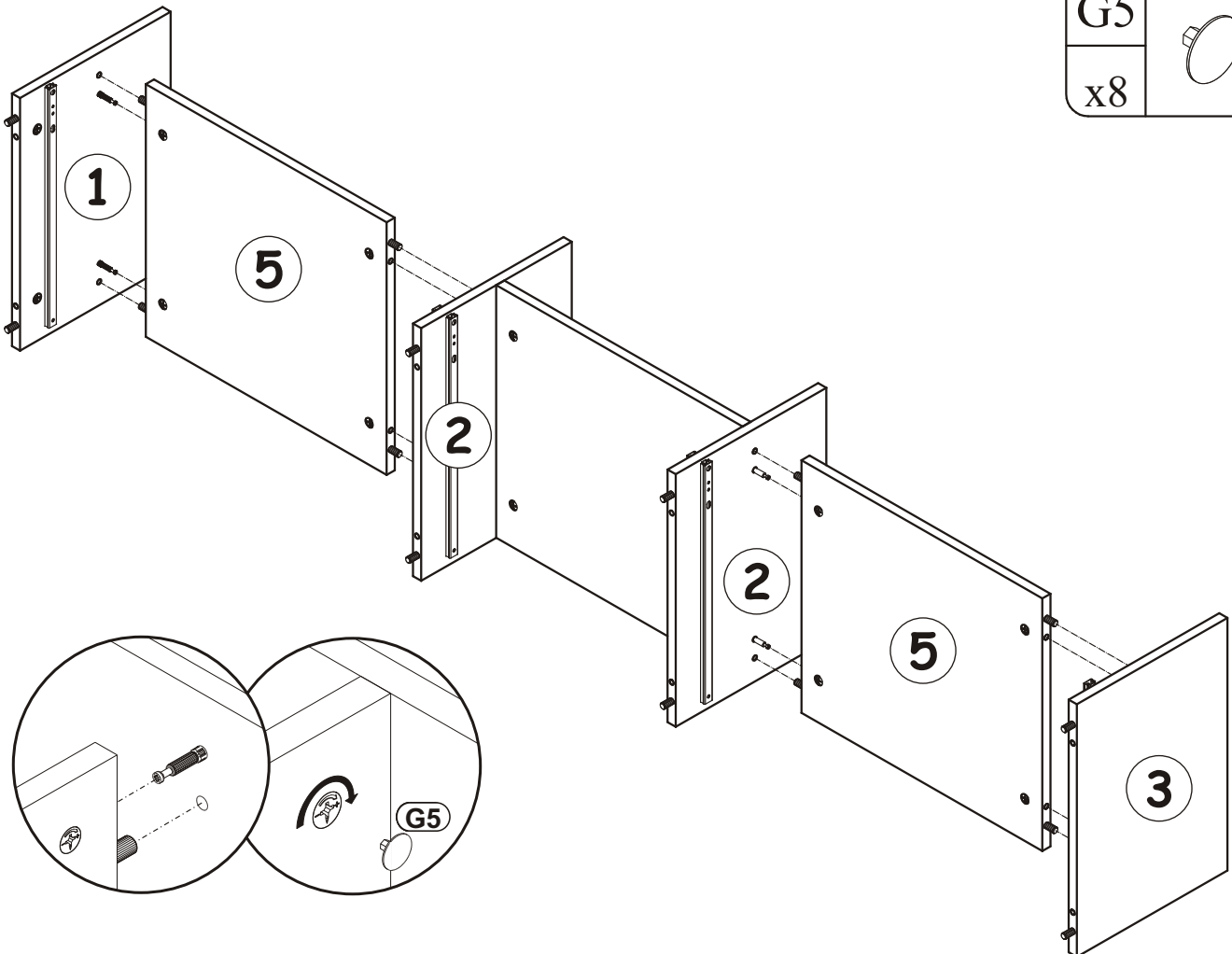

9

G5	
x8	



10

G5		I11		D11	
x8		x6		x6	ø3,5x25

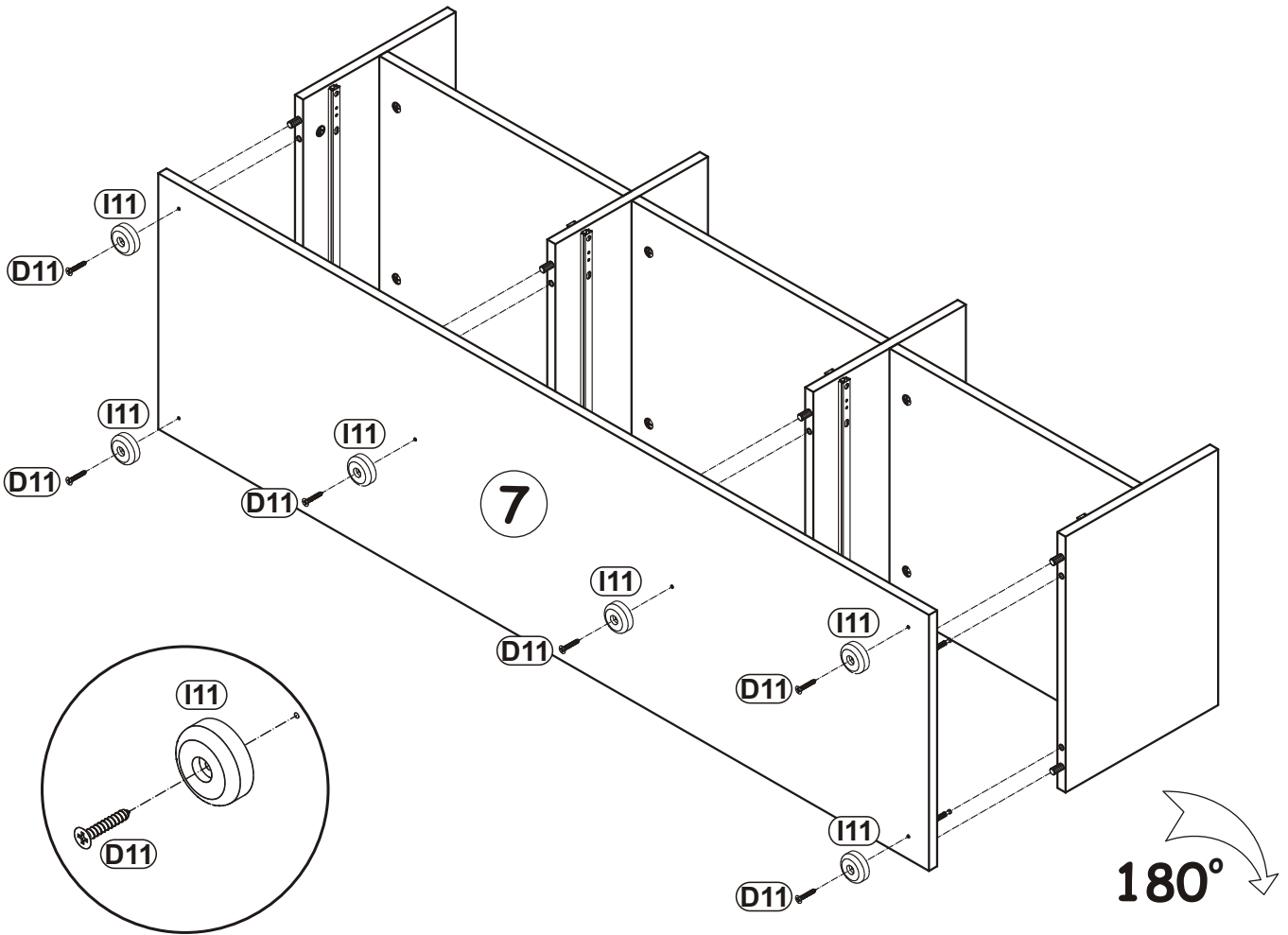

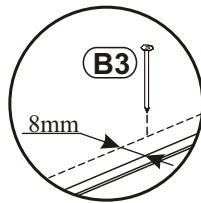
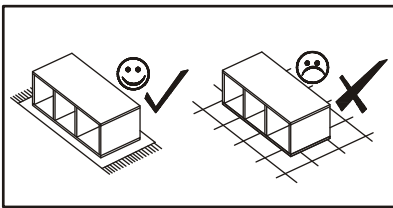

11

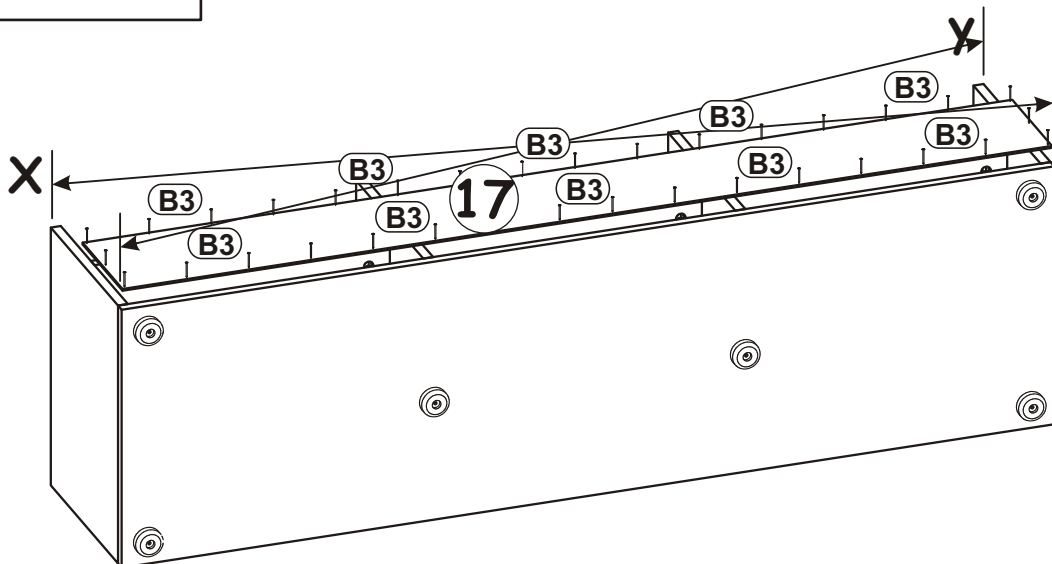

$X=Y$ 90°

B3	
x31	ø1,4x25



D18	
x6	M4x9

12

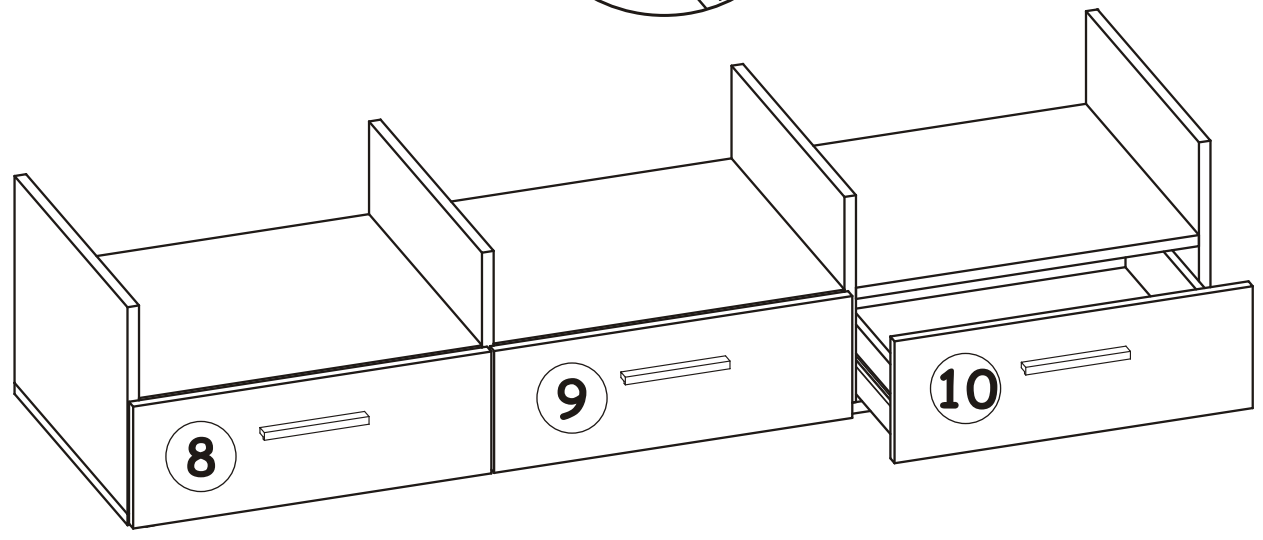
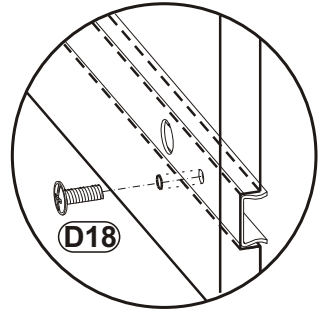

13

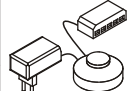
Z5		UL1	
x16		x1	

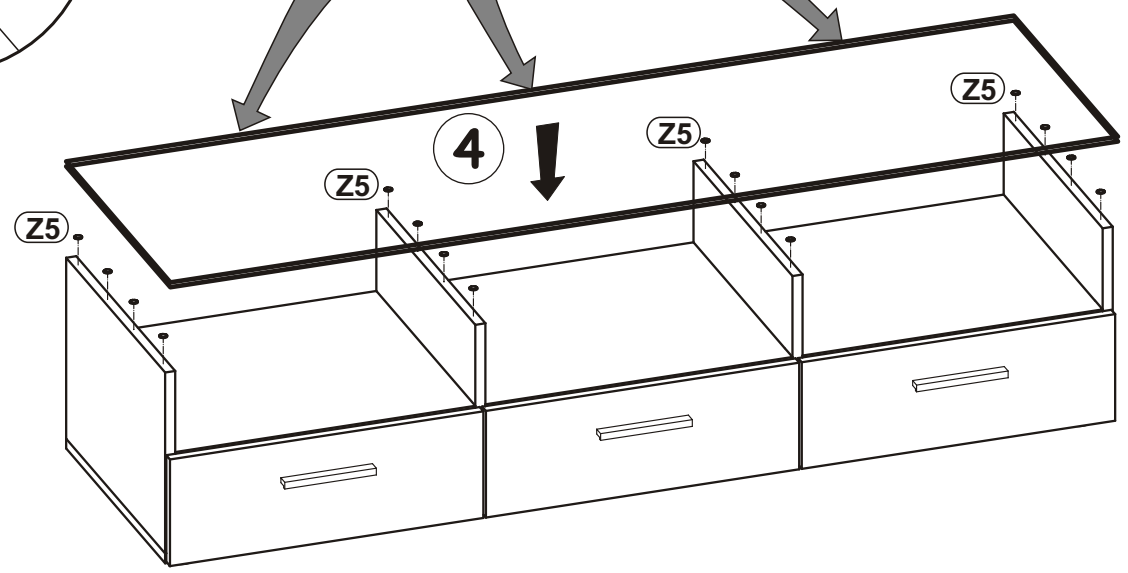
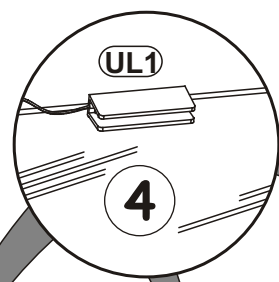
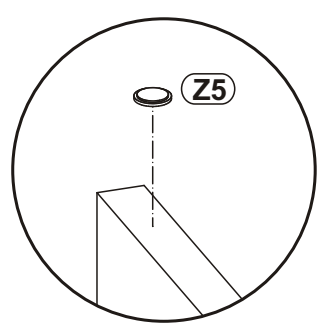

FRESH 28 -- FR-C-85

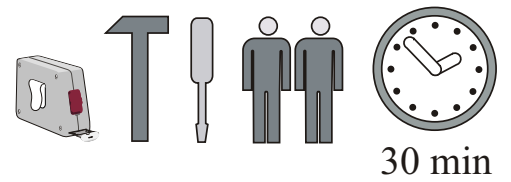
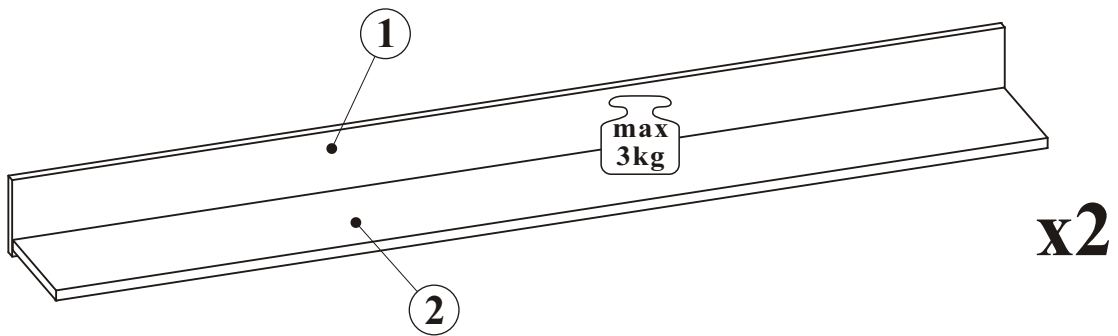
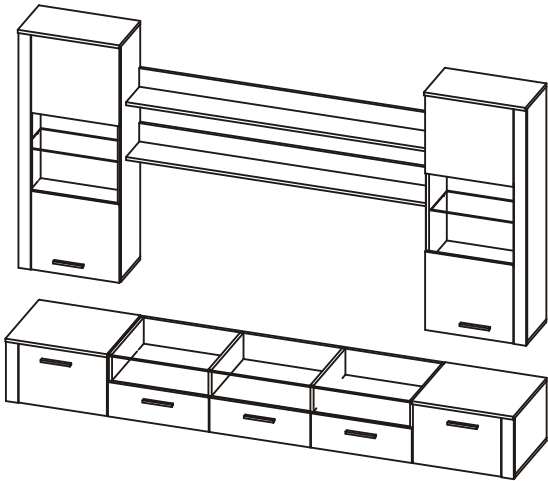
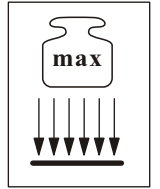

NO	Dim.		Col.-No	Qty
1	1500	120	1	2
2	1498	180	1	2

FRESH - 28 -- FR-C - 85

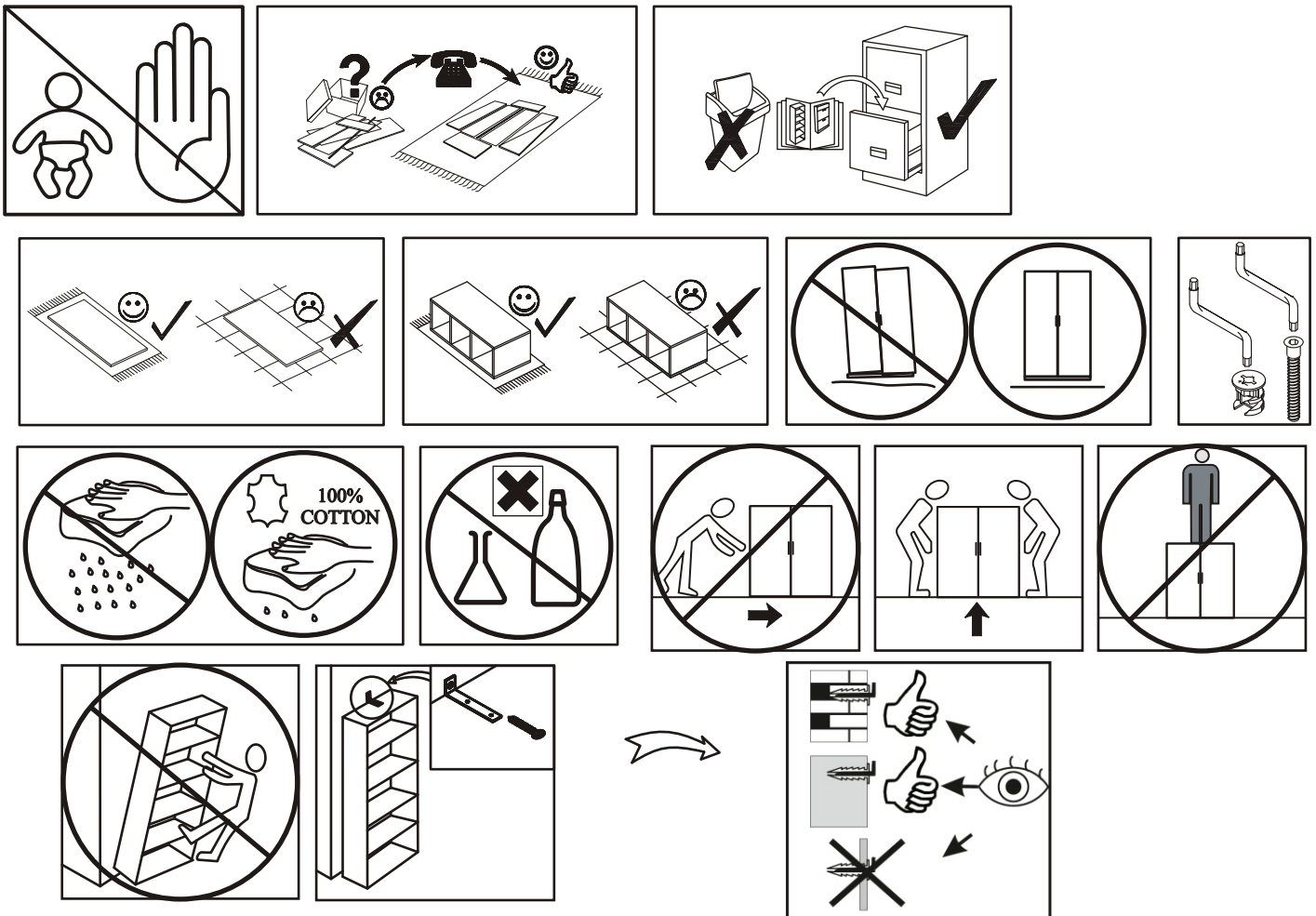
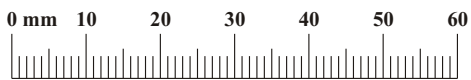
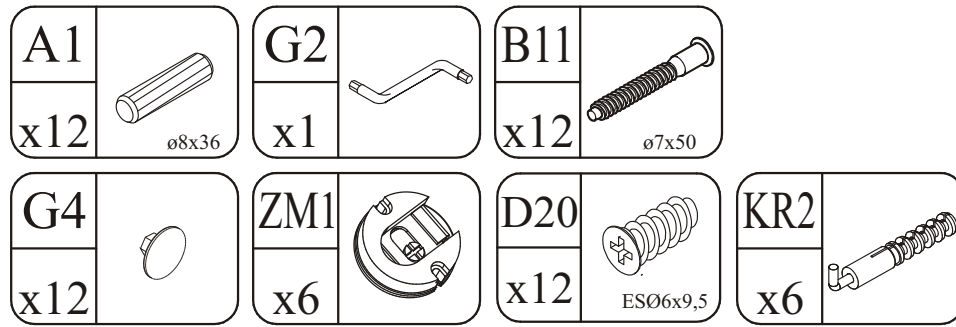

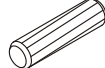
A1	
x12	ø8x36

ZM1	
x6	

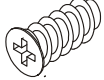
D20	
x12	ESØ6x9,5

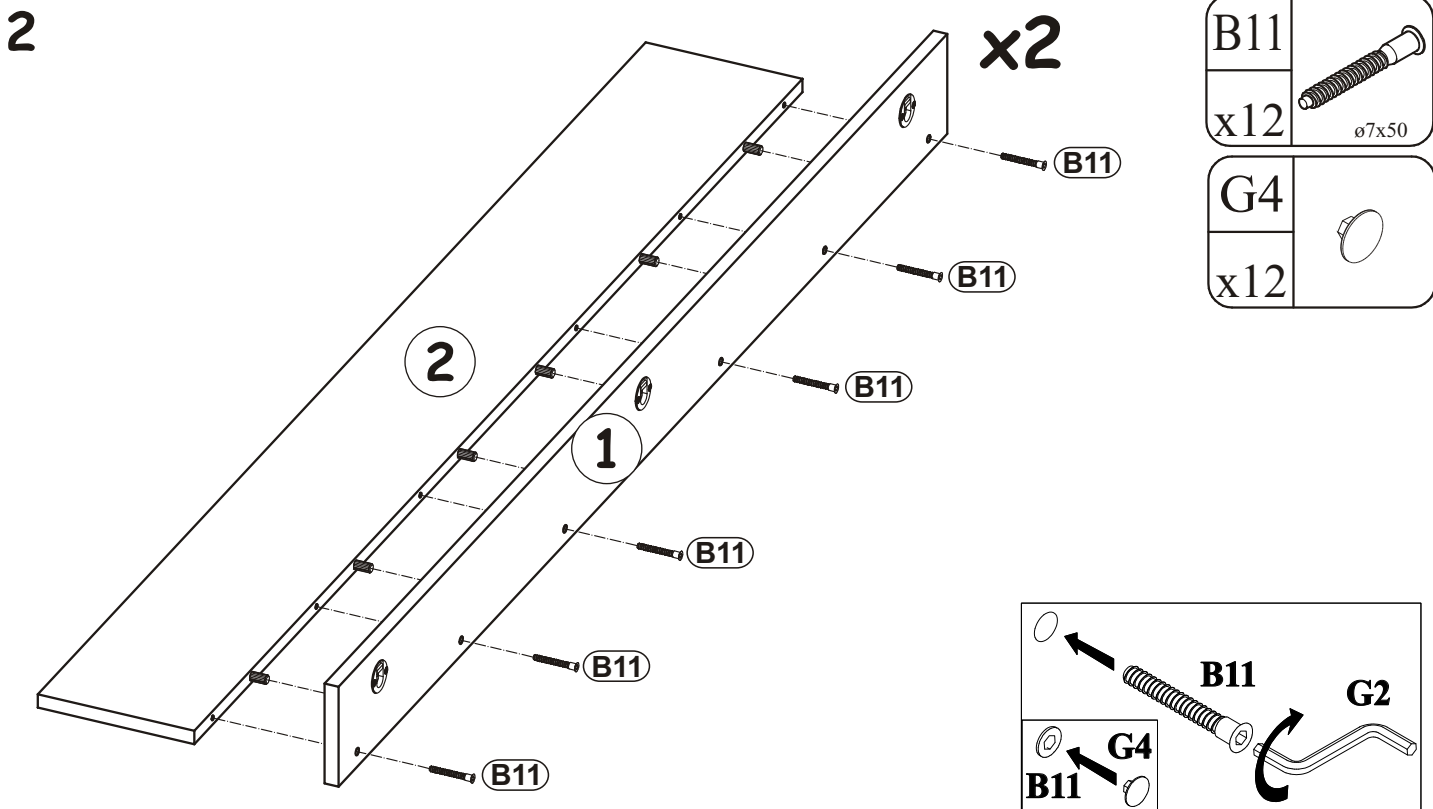
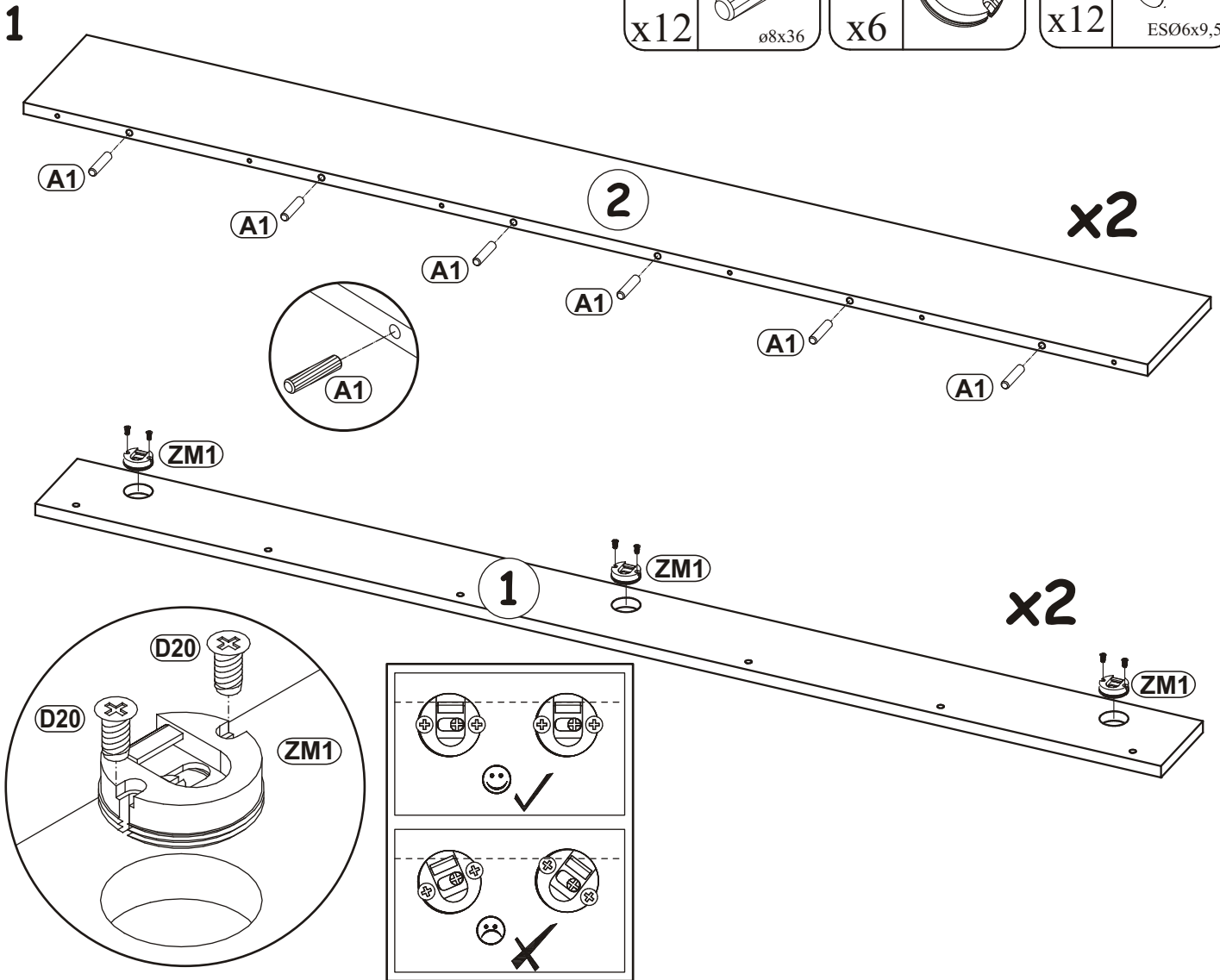

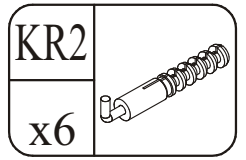

3

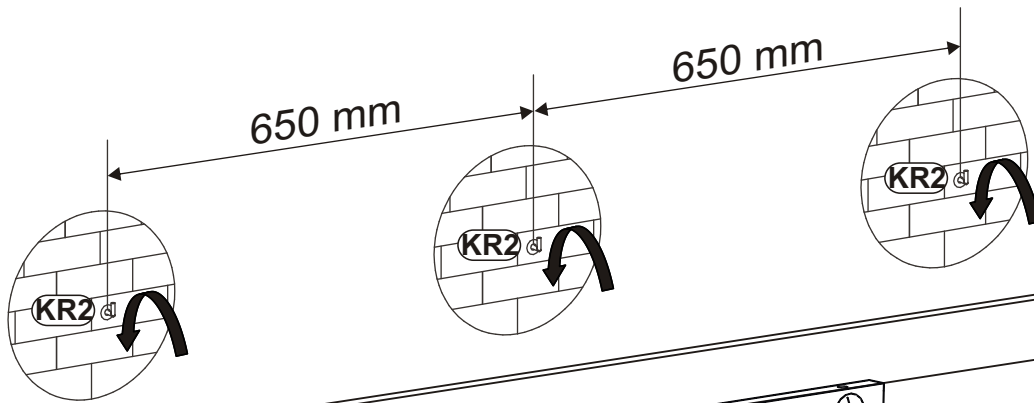
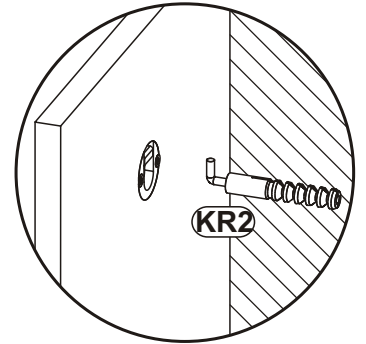
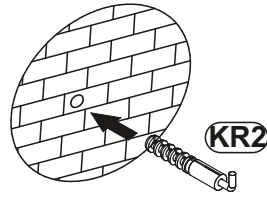
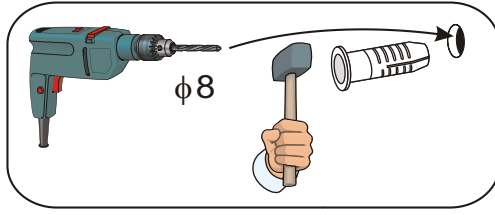
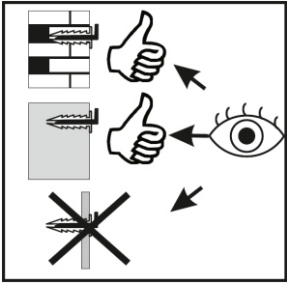

x2

