

# FLY 28 -- FY 35-C

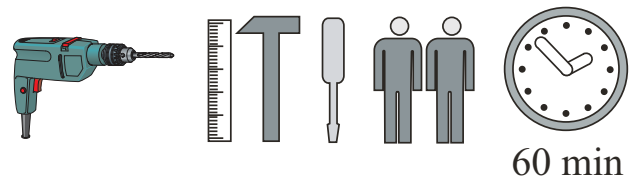

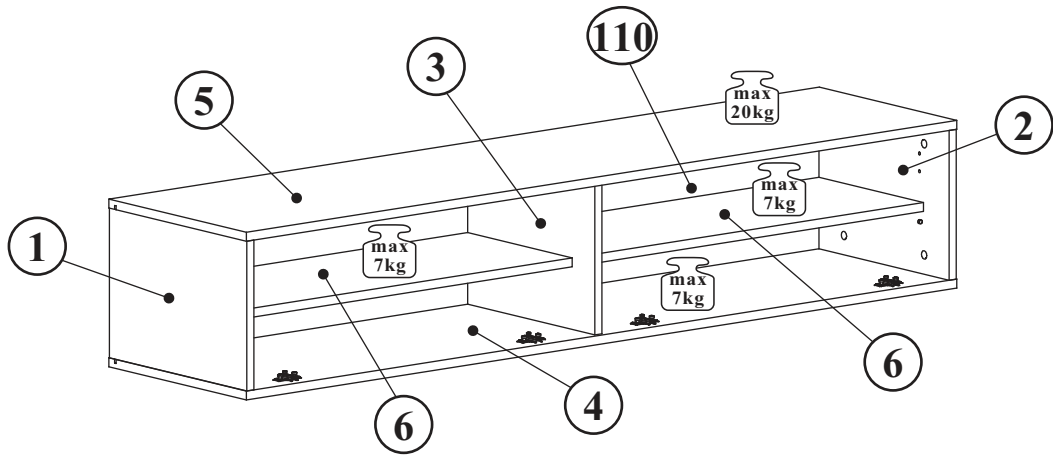

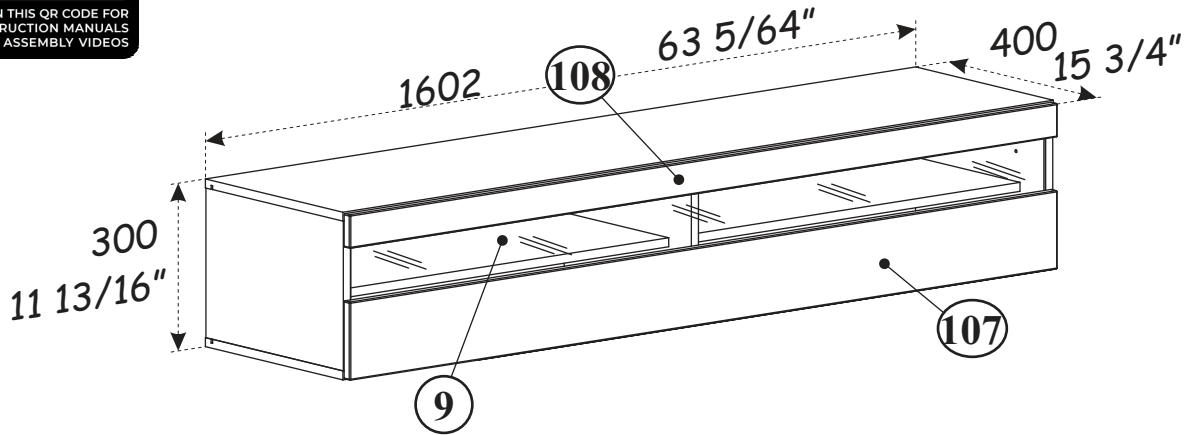

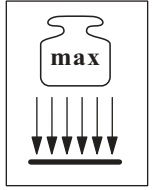
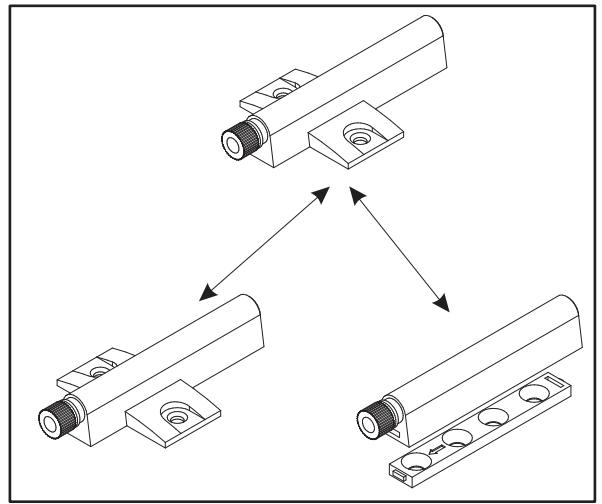
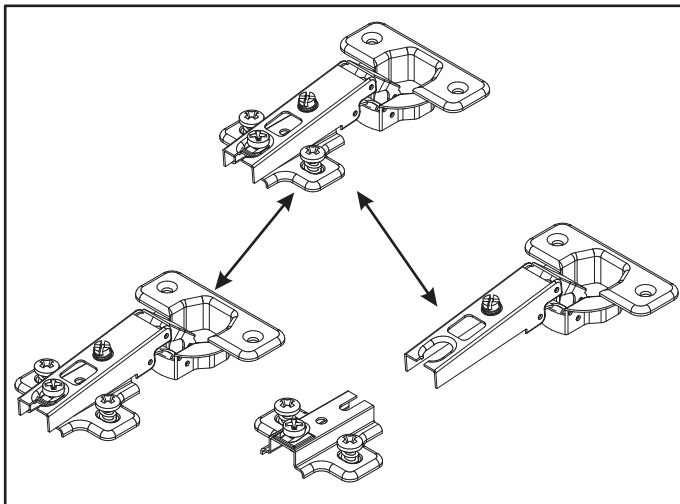
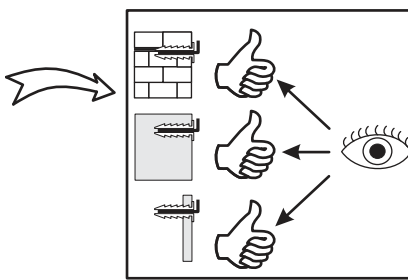
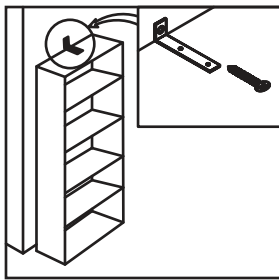
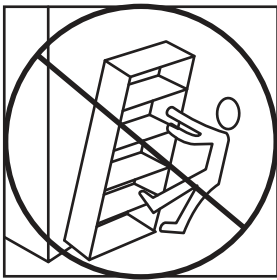
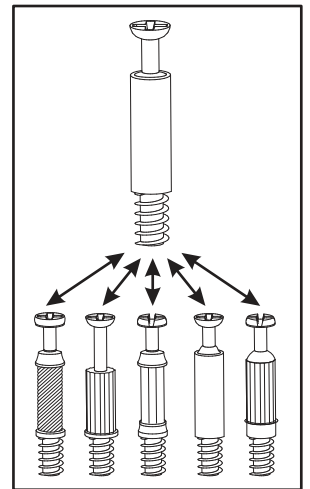
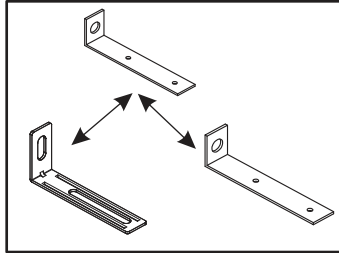
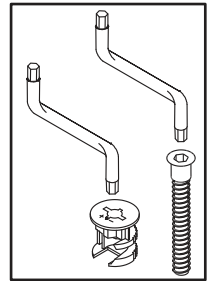
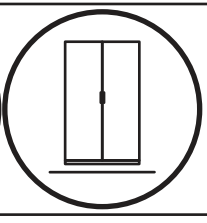
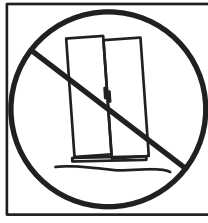
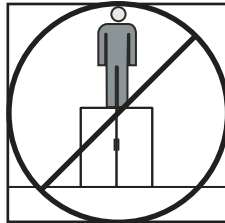
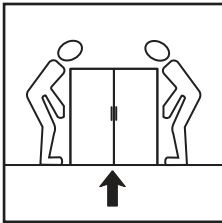
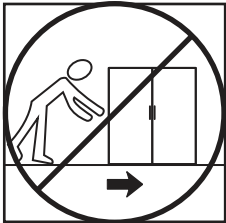
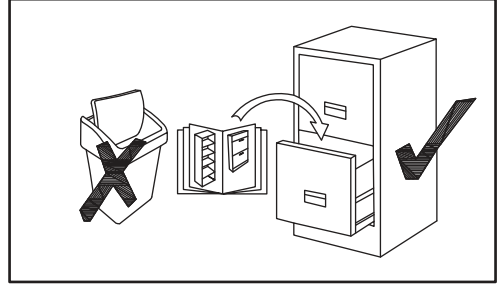
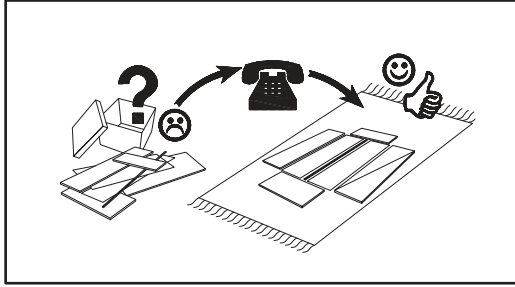
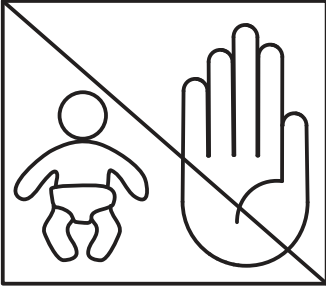
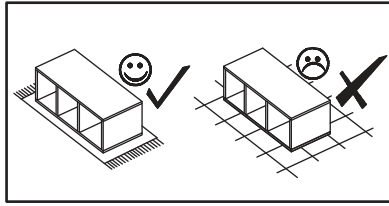
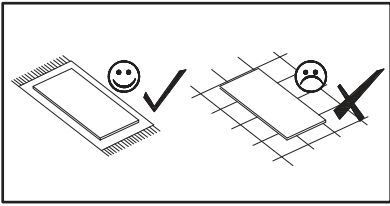



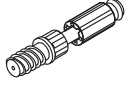

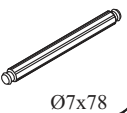

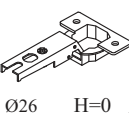
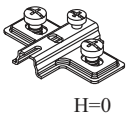
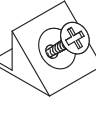

NO	Dim.			Col.-No	Qty
1	268	384	16	1	1
2	268	384	16	1	1
4	1602	384	16	1	1
5	1602	384	16	1	1
3	268	355	16	1	1
6	776	292	16	1	2
9	1566	146	4	1	1
110	1580	280	3	1	1
107	1596	140	16	1	1
108	1596	60	16	1	1

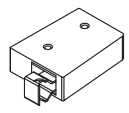
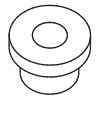
NO	Dim.			Col.-No	Qty
1	10 35/64	15 1/8	5/8	1	1
2	10 35/64	15 1/8	5/8	1	1
4	63 5/64	15 1/8	5/8	1	1
5	63 5/64	15 1/8	5/8	1	1
3	10 35/64	13 31/32	5/8	1	1
6	30 35/64	11 1/2	5/8	1	2
9	61 21/32	5 3/4	5/32	1	1
110	62 13/64	11 1/32	1/8	1	1
107	62 53-64	5 33/64	5/8	1	1
108	62 53-64	2 23/64	5/8	1	1

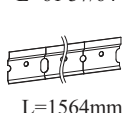

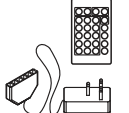
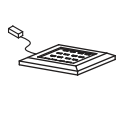
FLY 28--FY 35-C

A1 x20  Ø5/16"x1 27/64" ø8x36	B4 x16 	B5 x20  Ø19/32"x15/32" ø15x12	G5 x20 	B6 x2  Ø 9/32"x 3 5/64" Ø7x78	G2 x1 
E1 x4  Ø1 1/32" Ø26 H=0	E2 x4  H=0	S1 x10 	D6 x6  USØ9/64"x1 3/16" USØ3,5x30	D10 x14  USØ9/64"x33/64" USØ3,5x13	G21 x2 
ZR1 x3 	P2 x12 	KR5 SFXP x4  Ø 25/64"/1 31/32" x2 23/64" Ø10/50x60	SZ9 x1  L=61 37/64" L=1564mm	D7 x6  USØ1/8"x5/8" USØ3x16	AM x1 
LZ3 x1 	SQ x2 	UP13 x12  UpØ 1/8"x5/8" UPØ3x16			

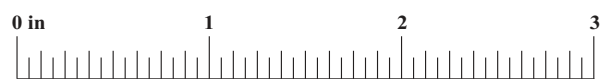
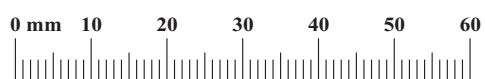
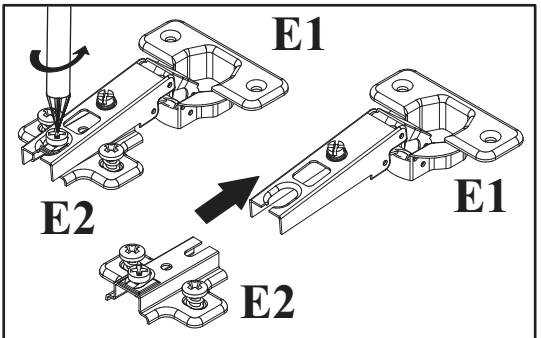

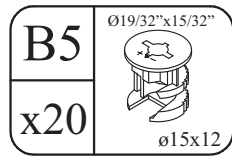
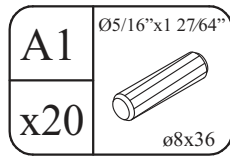
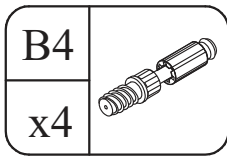

1

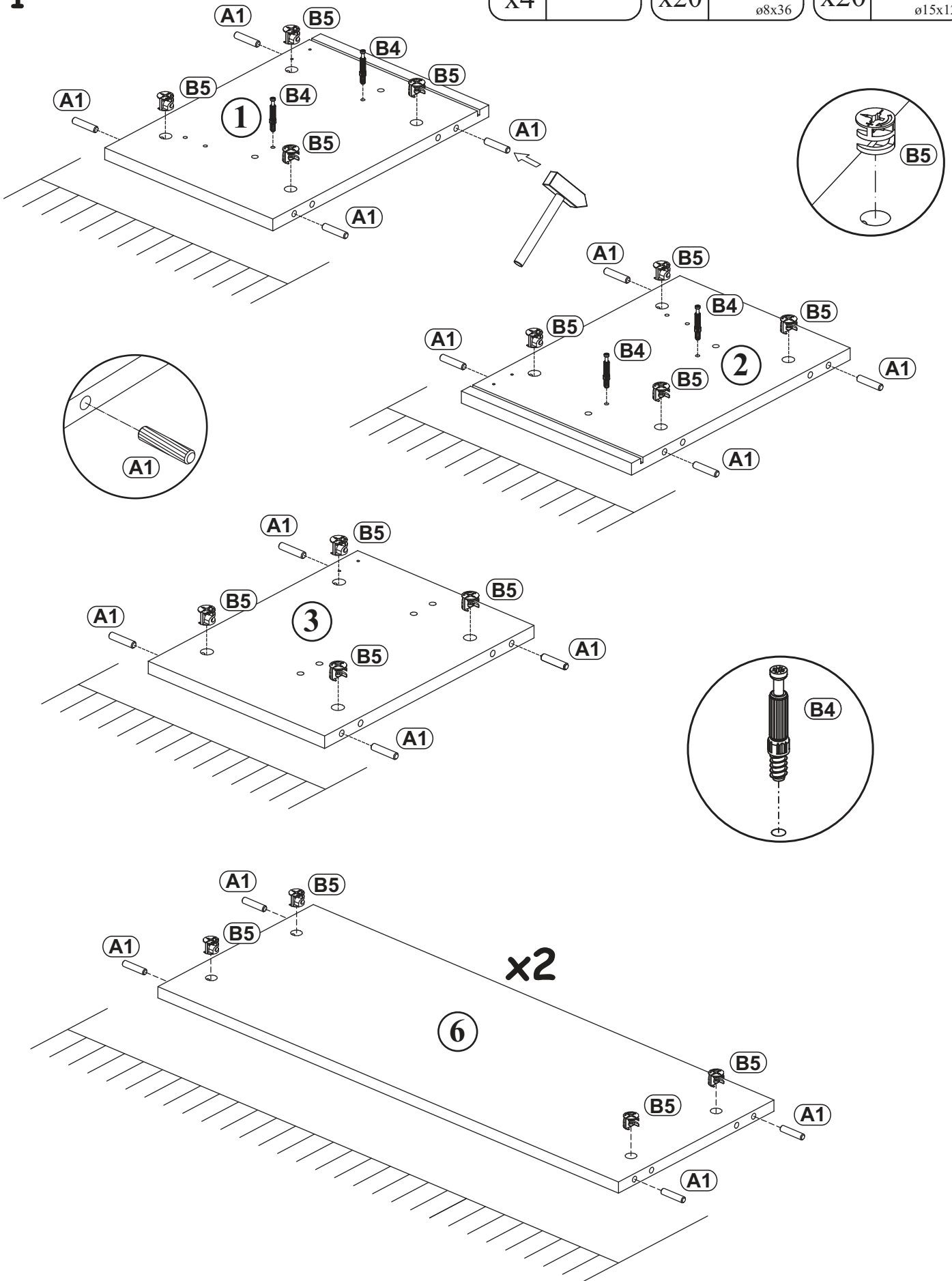

2

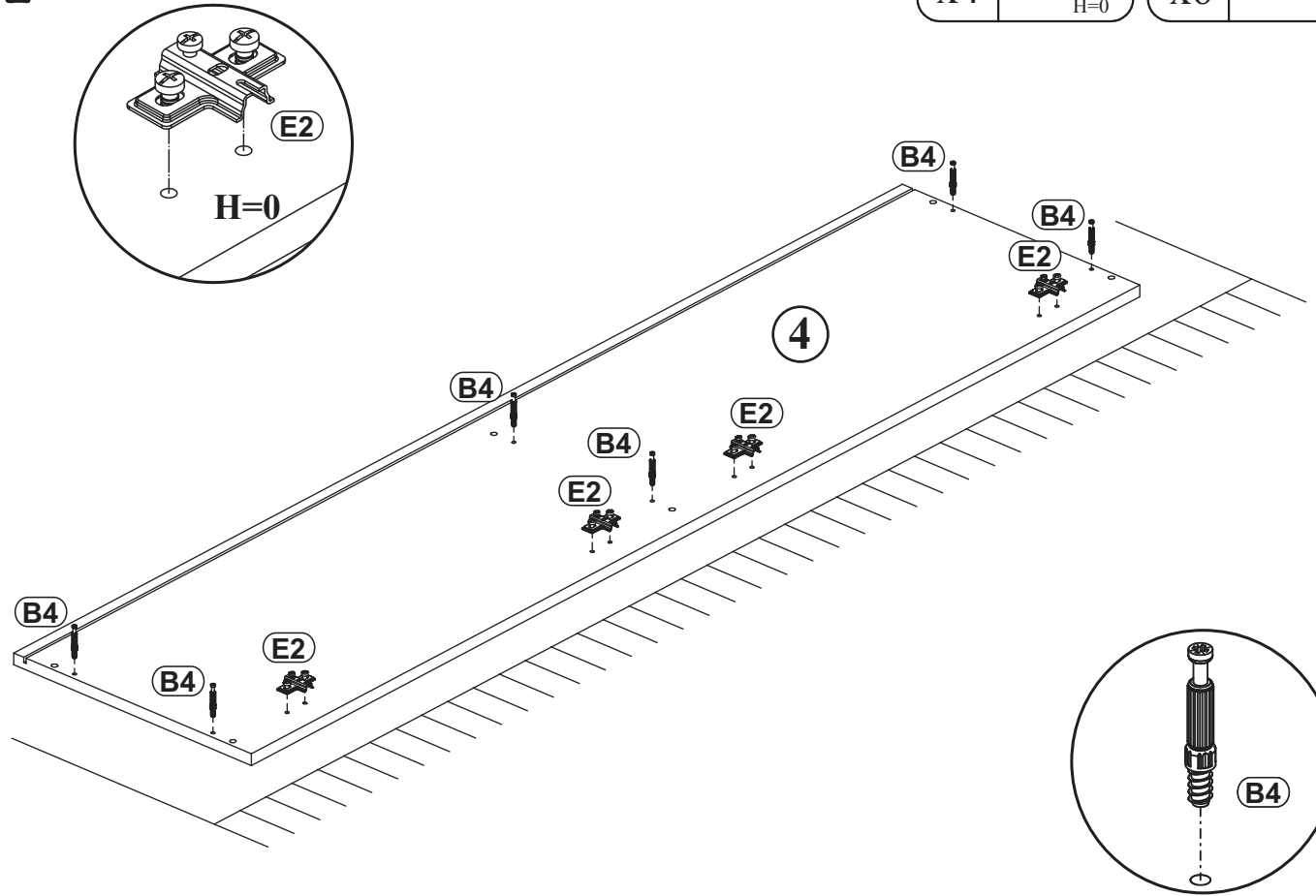

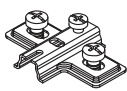
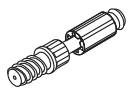
E2		B4	
x4	H=0	x6	

3

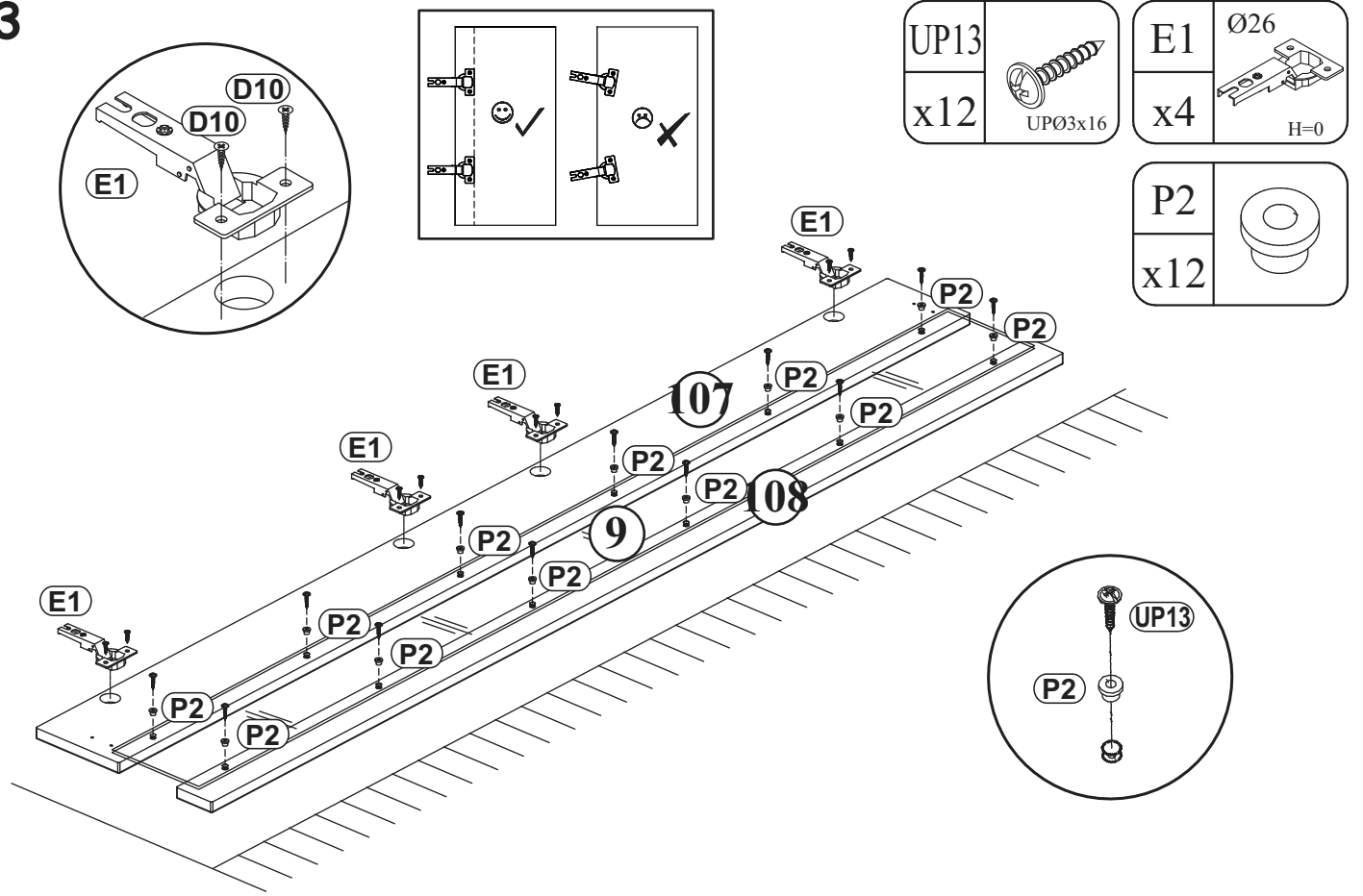

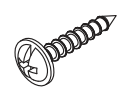
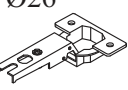
UP13		E1	
x12	UPØ3x16	x4	H=0

P2	
x12	

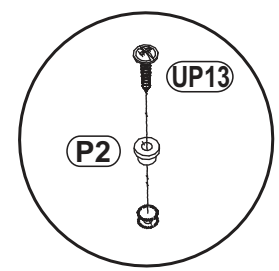

4

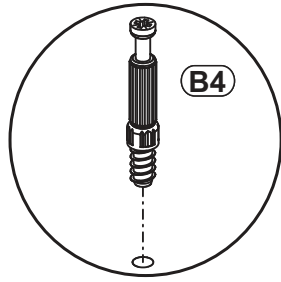

SQ		B4	
x2		x6	

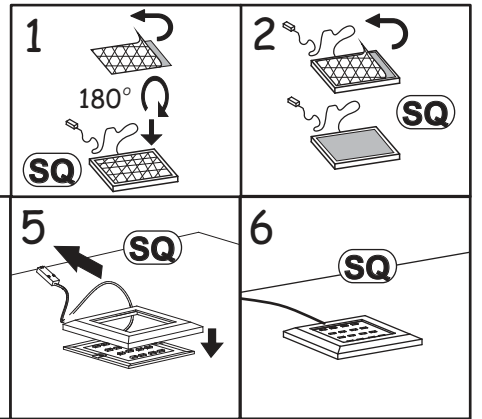
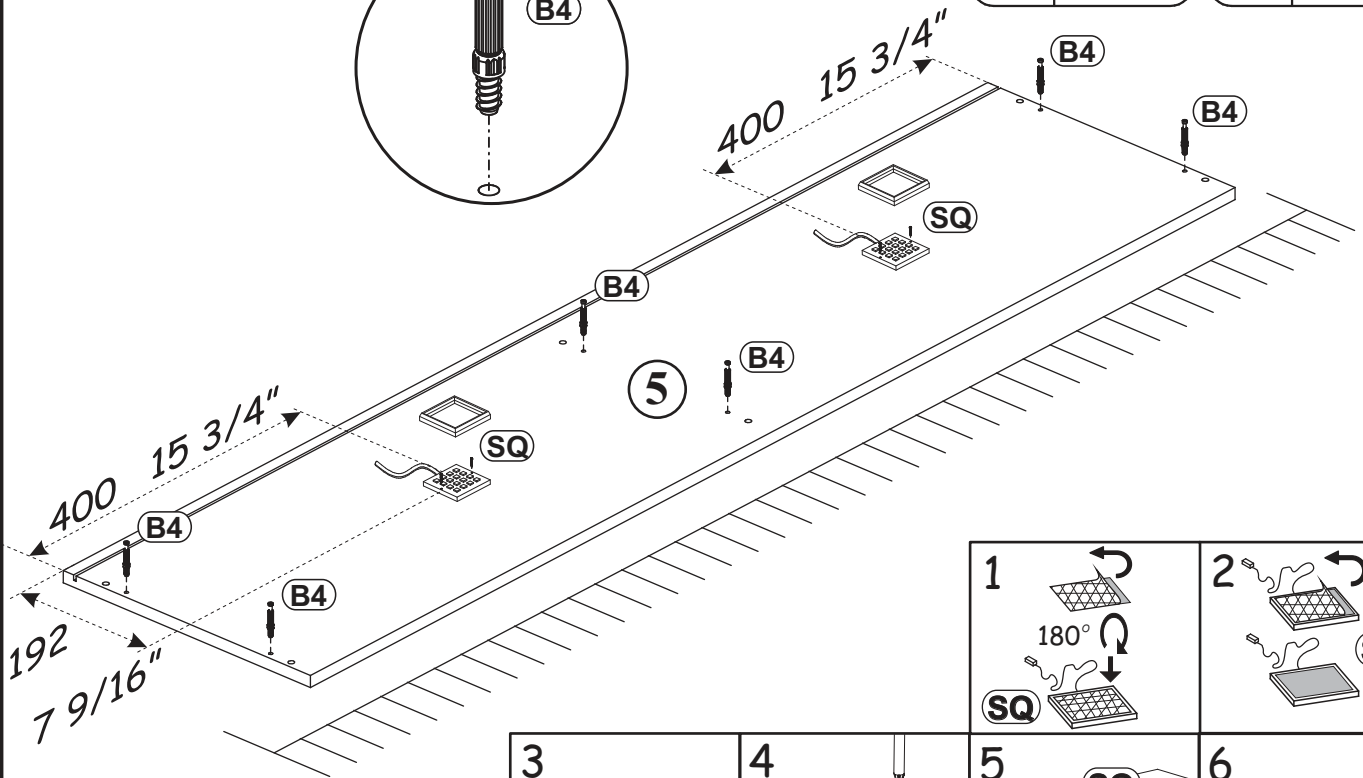

5

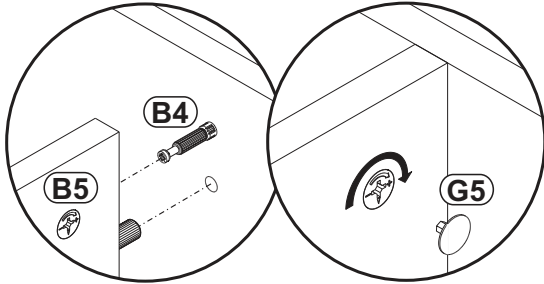

G5		B6	
x8		x2	Ø 9/32" x 3 5/64"
			Ø7x78

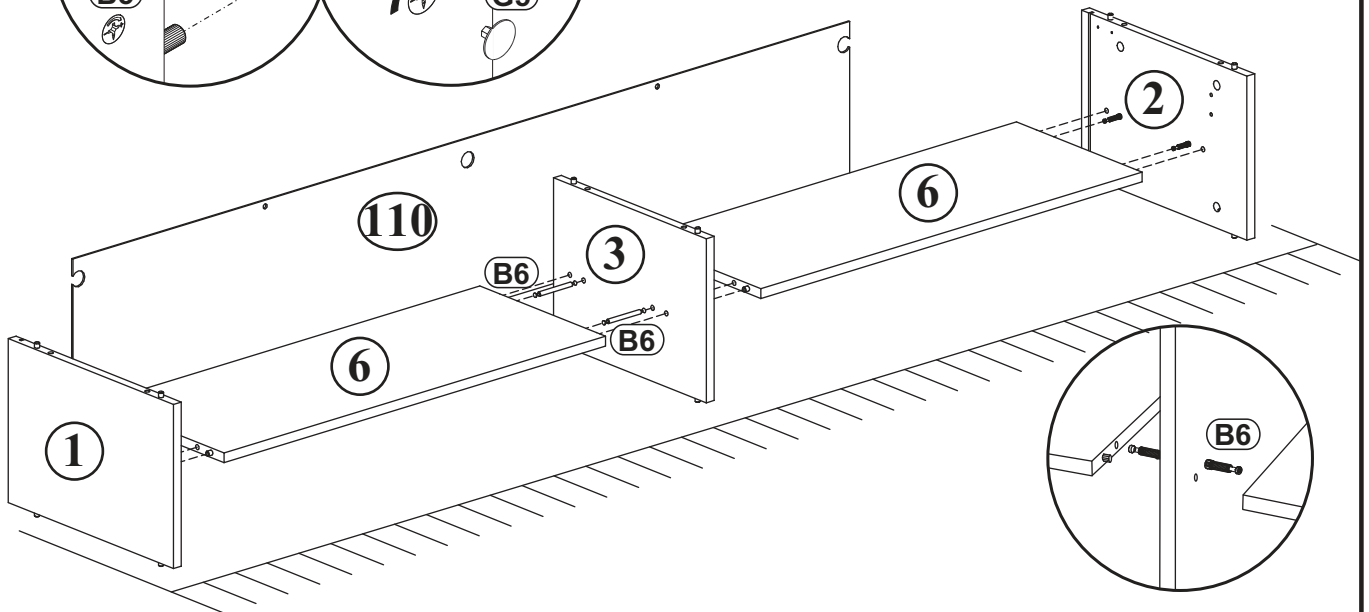

6

G5	
x12	

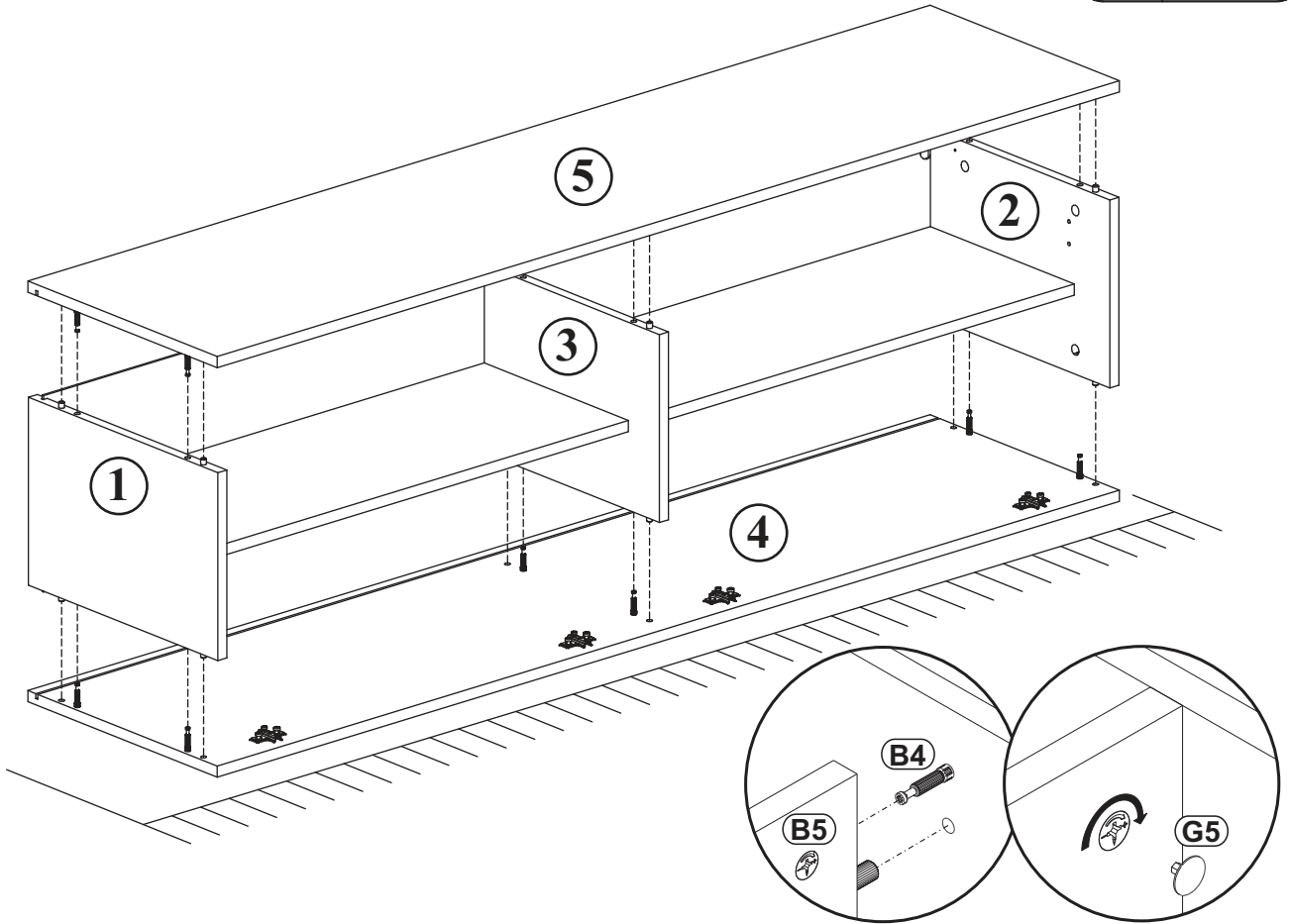

7

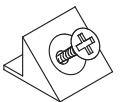
S1	
x10	

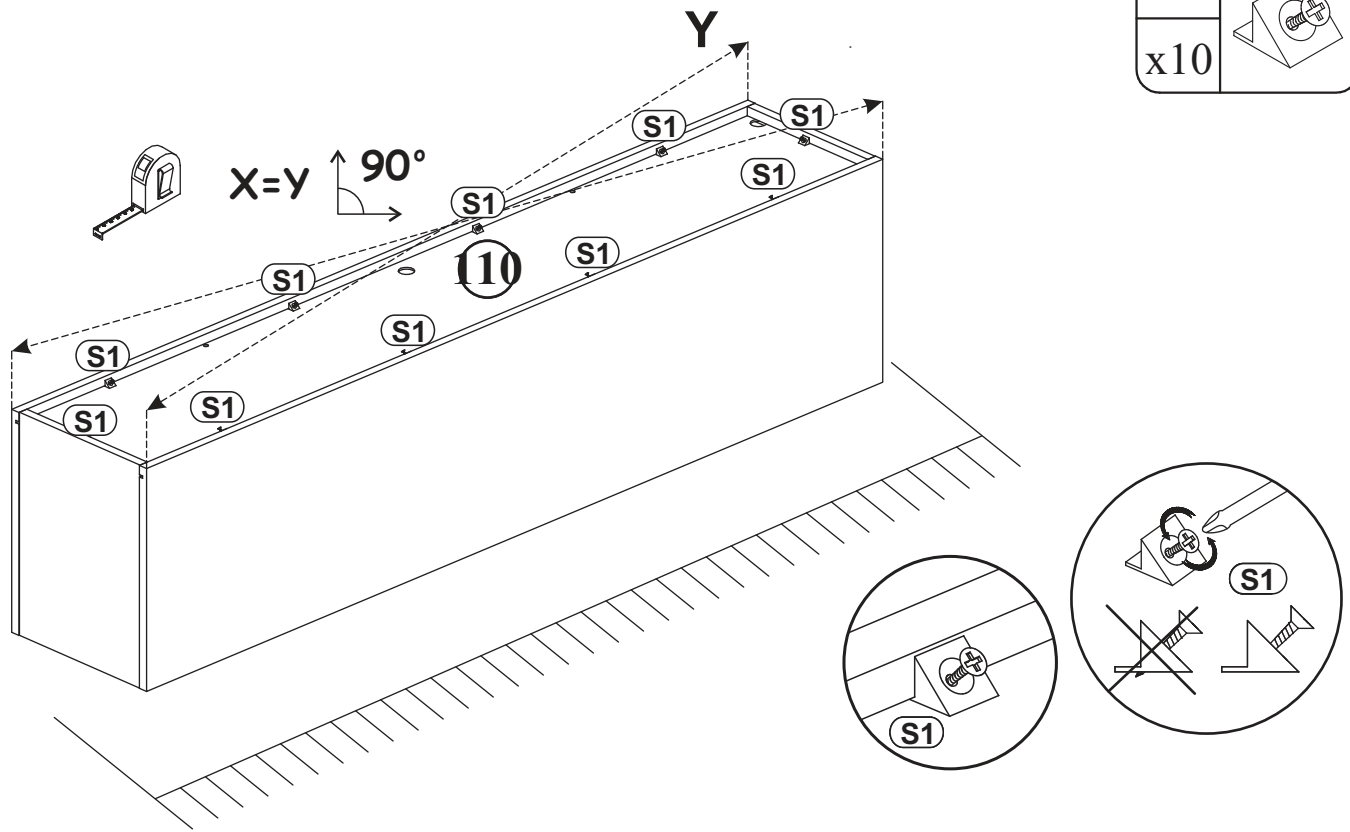

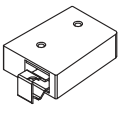
D6		ZR1	
x6	USØ3,5x30	x3	

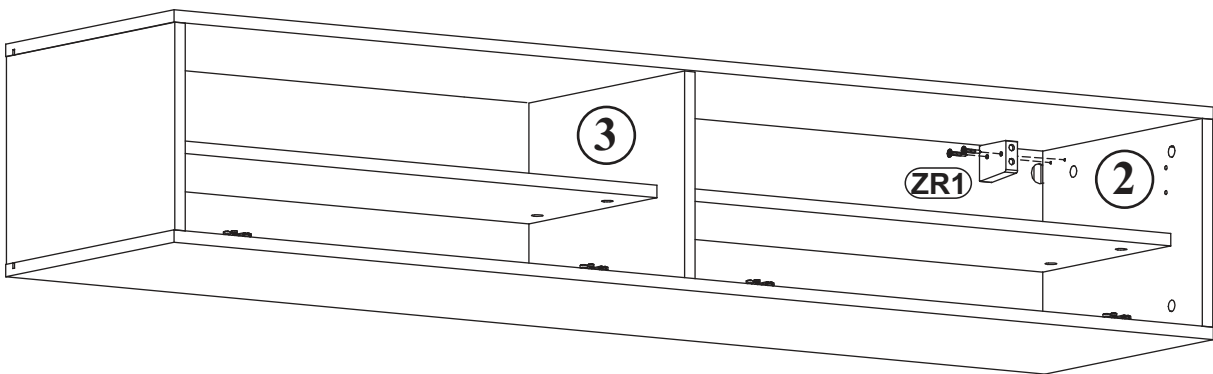
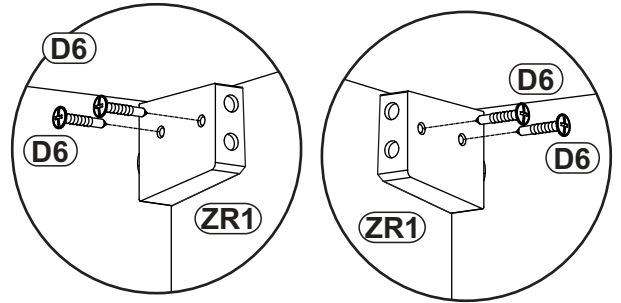
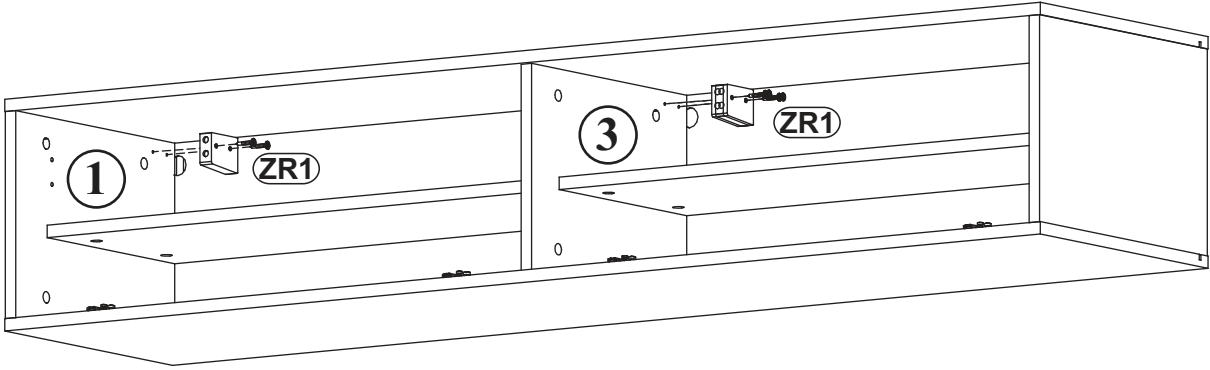



**KR5**  
SFXP  
x4  
Ø 25/64"/1 31/32"  
x2 23/64"  
Ø10/50x60



**SZ9**  
L=61 37/64"  
x1  
L=1564mm



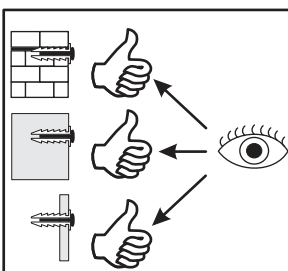
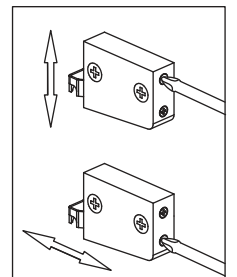
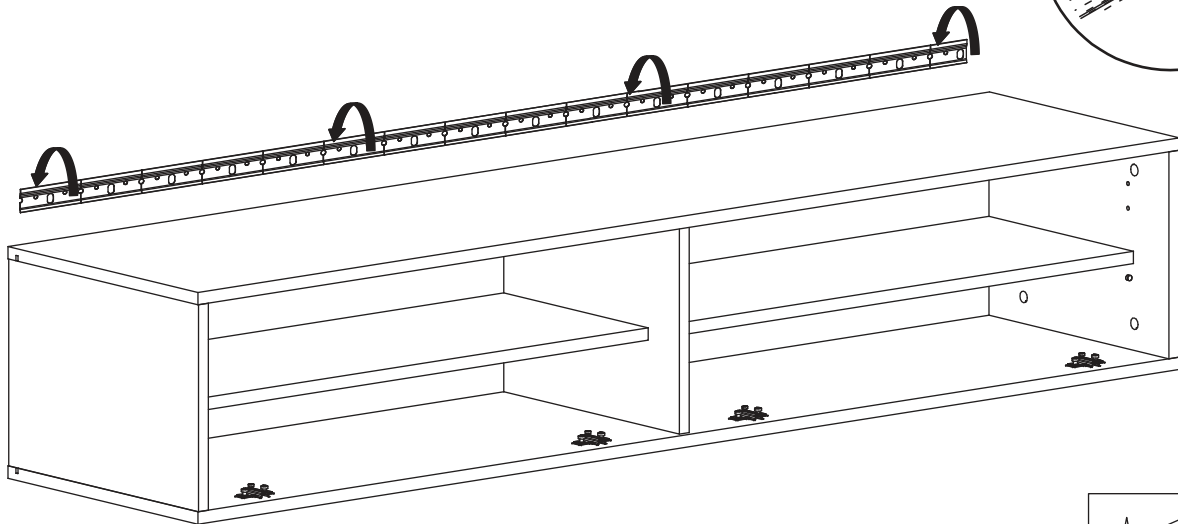
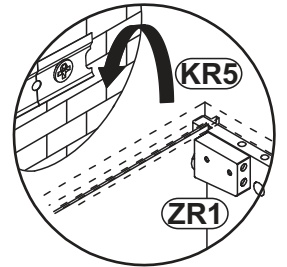
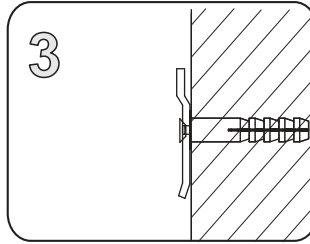
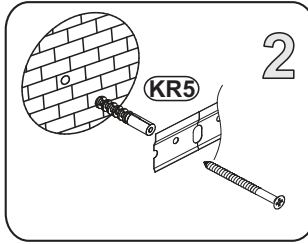
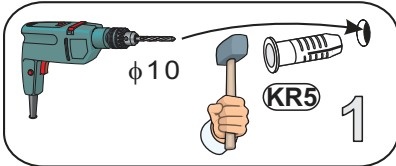
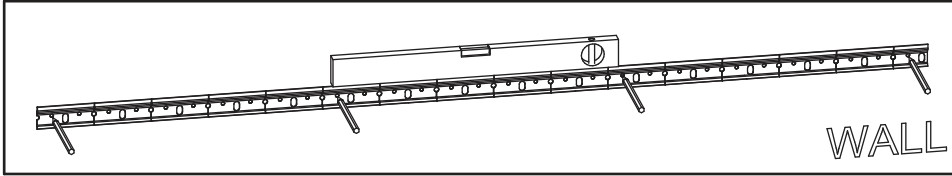
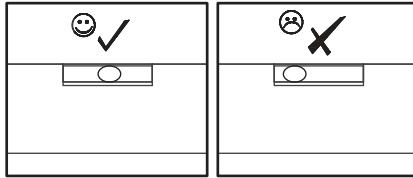

8

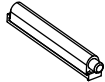

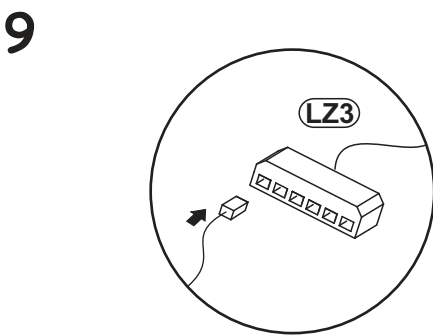
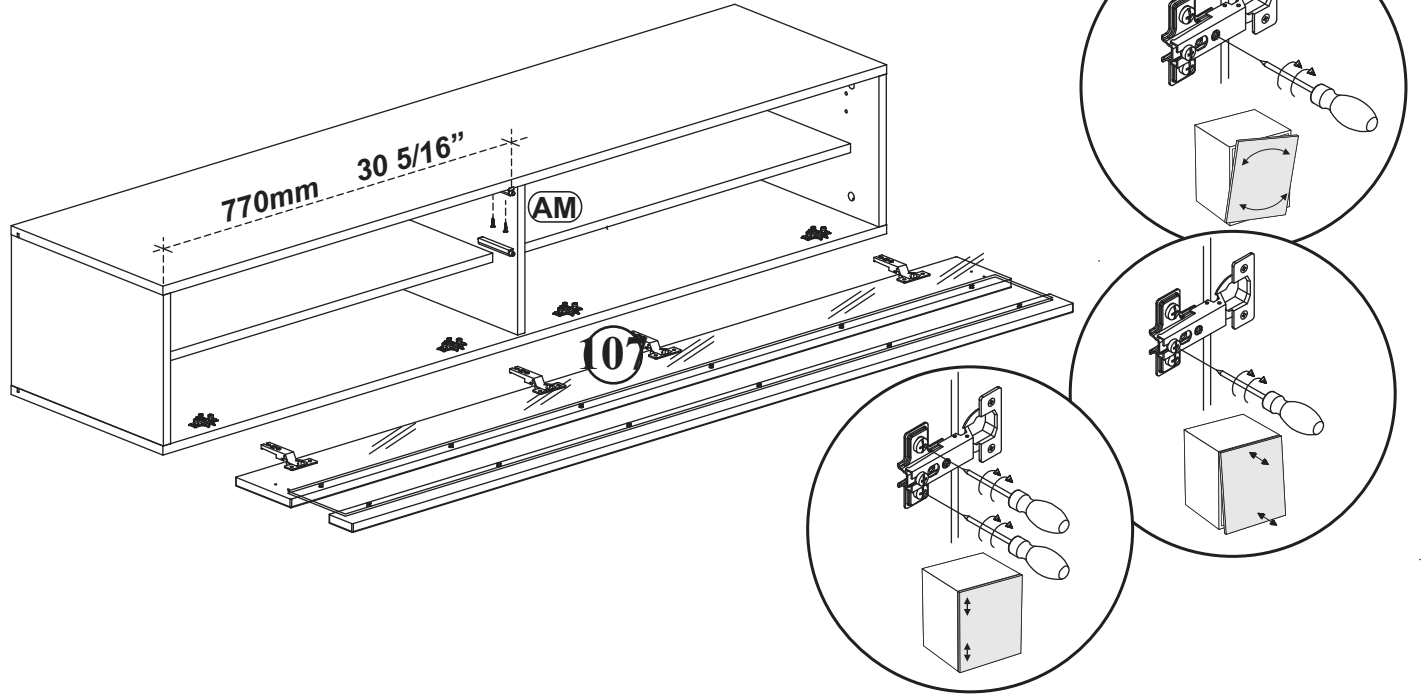
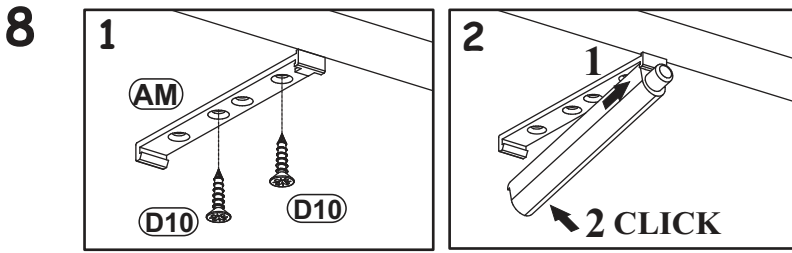
AM		D10	US09/64"x33/64"
x1		x2	USØ3,5x13



LZ3		D10	US09/64"x33/64"	G21	
x1		x4	USØ3,5x13	x2	
				D7	USØ1/8"x5/8"
				x6	USØ3x16

