

FLY 28 -- FY 30-C

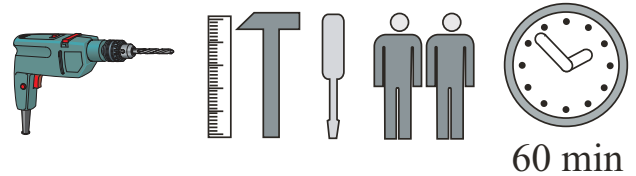

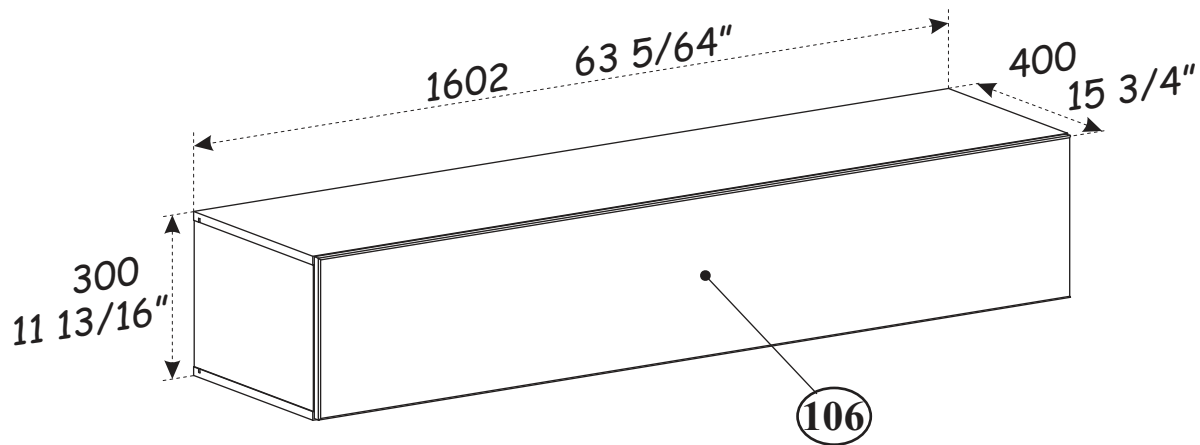

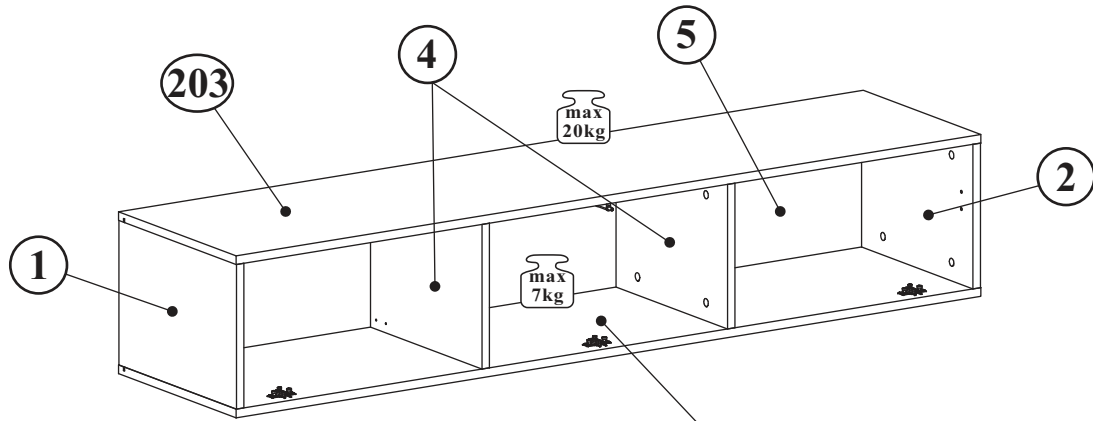

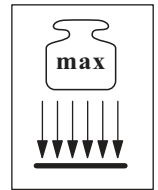
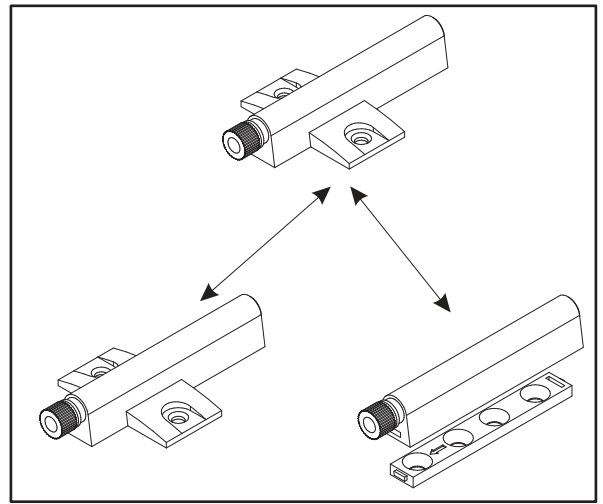
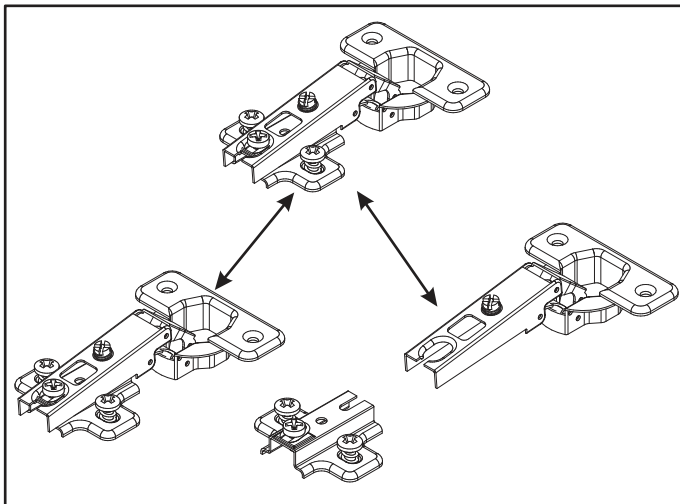
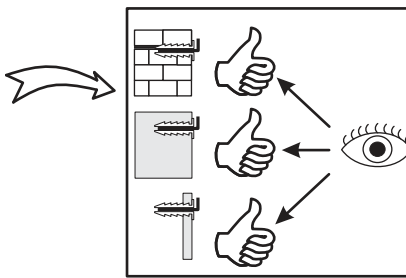
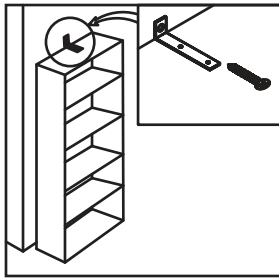
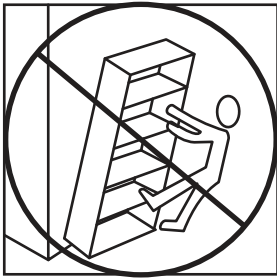
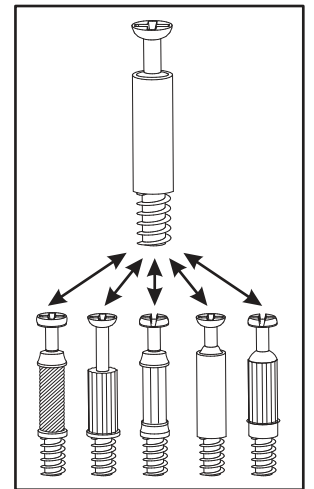
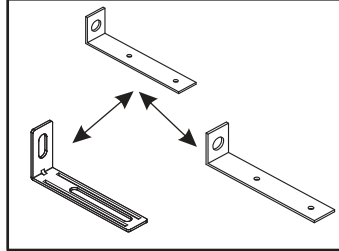
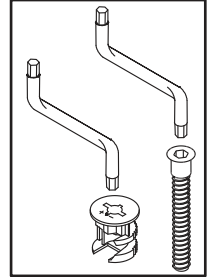
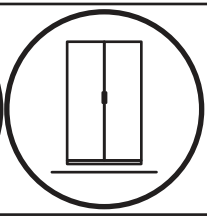
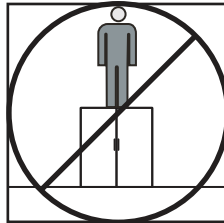
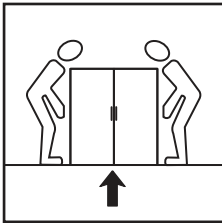
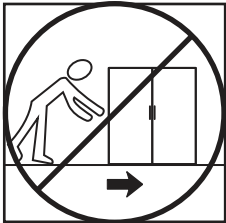
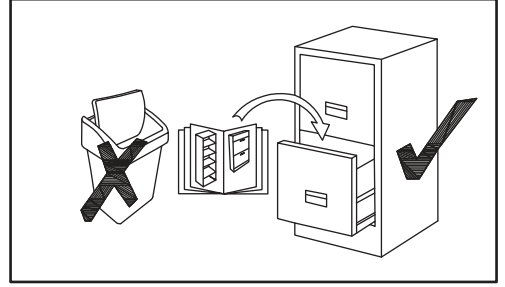
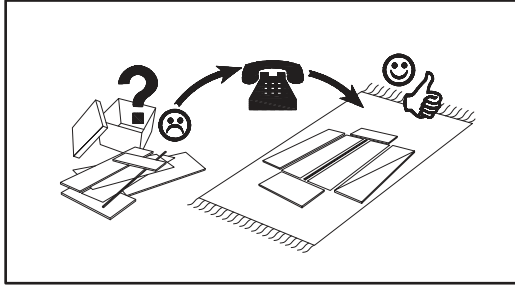
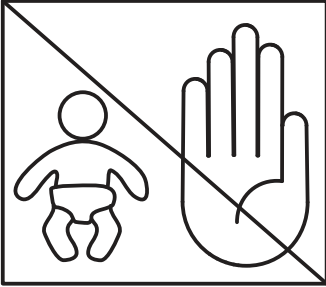
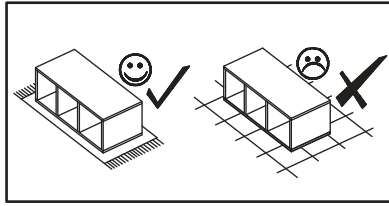
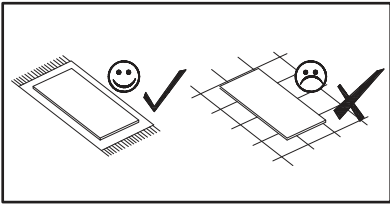

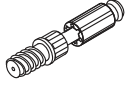

NO	Dim.			Col.-No	Qty
1	268	384	16	1	1
2	268	384	16	1	1
103	1602	384	16	1	1
203	1602	384	16	1	1
4	268	364	16	1	2
5	1580	280	3	1	1
106	1596	296	16	1	1

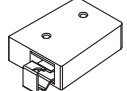
NO	Dim.			Col.-No	Qty
1	10 35/64	15 1/8	5/8	1	1
2	10 35/64	15 1/8	5/8	1	1
103	63 5/64	15 1/8	5/8	1	1
203	63 5/64	15 1/8	5/8	1	1
4	10 35/64	14 21/64	5/8	1	2
5	62 13/64	11 1/32	1/8	1	1
106	62 53/64	11 21/32	5/8	1	1

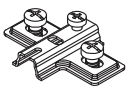

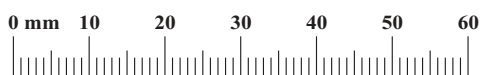
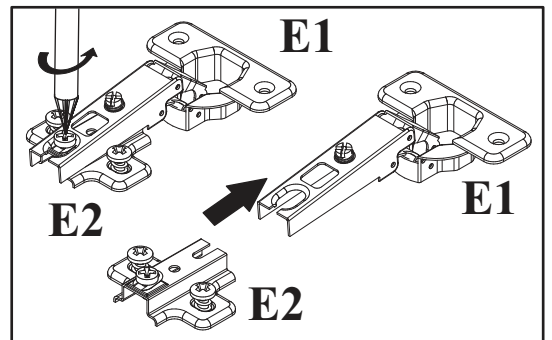

FLY 28--FY 30-C

A1 x16	Ø5/16"x1 27/64" ø8x36	B4 x16		B5 x16	Ø19/32"x15/32" ø15x12	G5 x16		ZR1 x4		S1 x12	
E2 x3	 H=0	E1 x3	Ø1 1/32" Ø26 H=0	G21 x2		KR5 SFXP x4	Ø 25/64"/1 31/32" x2 23/64" Ø10/50x60	D7 x6	USØ1/8"x5/8" USØ3x16	D6 x8	USØ9/64"x1 3/16" USØ3,5x30
D10 x12	USØ9/64"x33/64" USØ3,5x13	AM x1		SZ9 x1	L=61 37/64" L=1564mm	G2 x1					



1

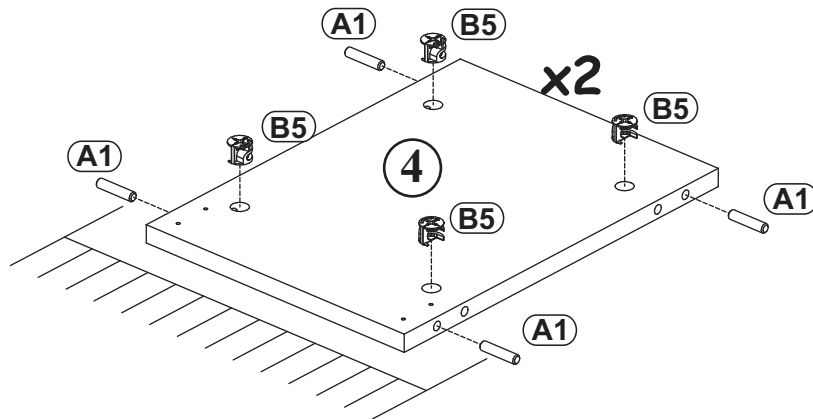
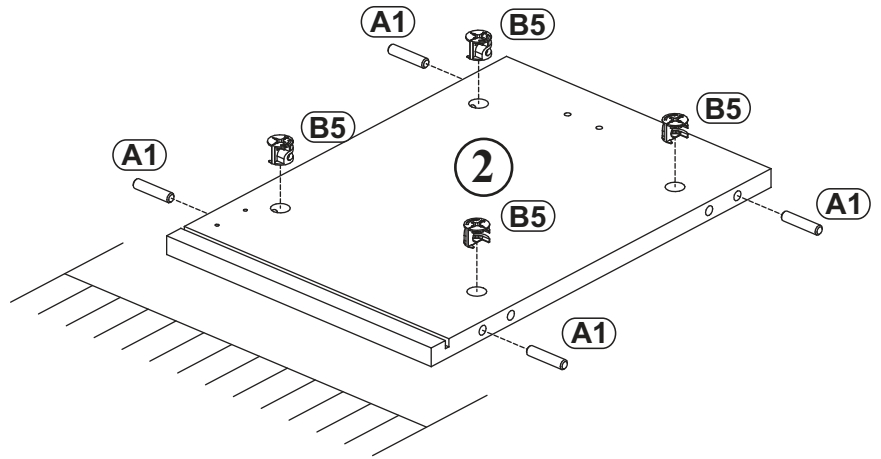
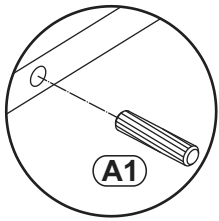
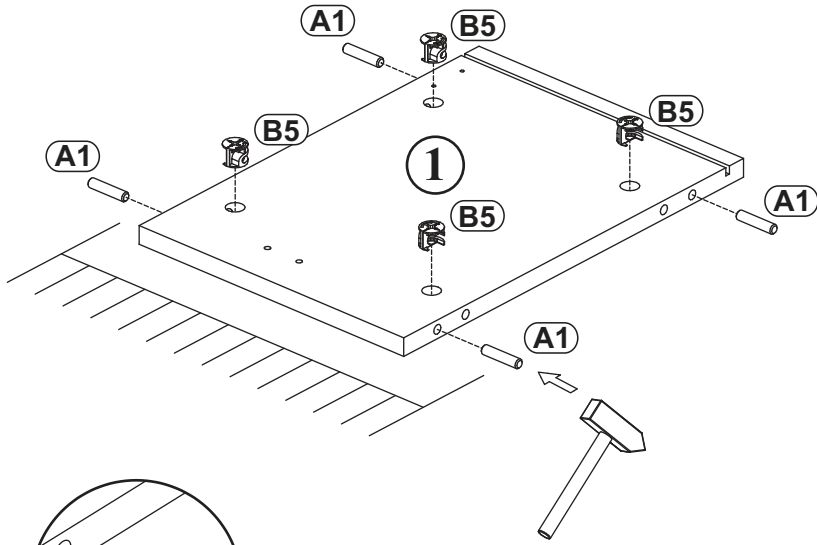

A1	Ø5/16"x1 27/64"	B5	Ø19/32"x15/32"
x16	 ø8x36	x16	 ø15x12

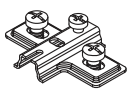
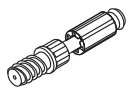

2

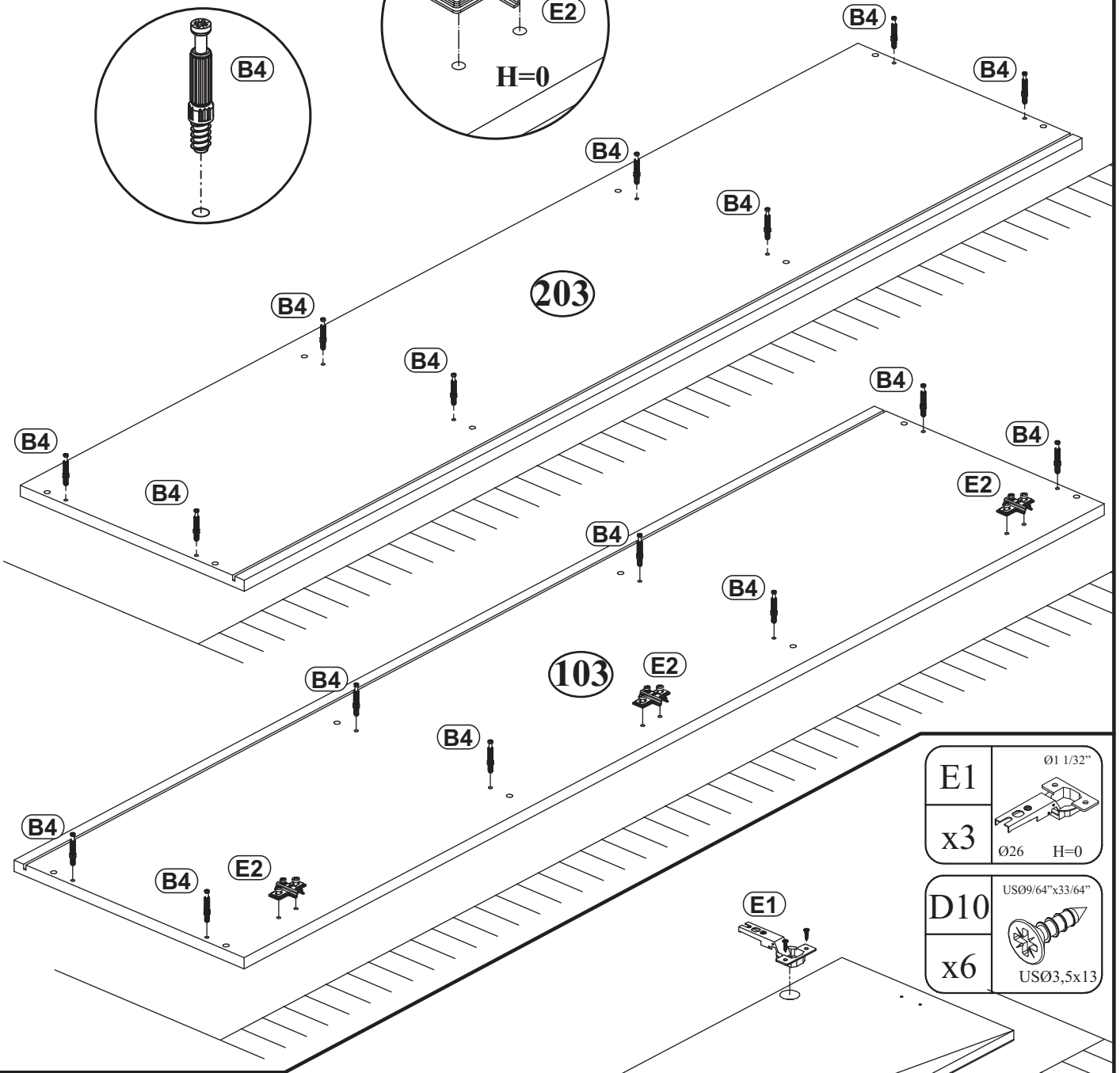
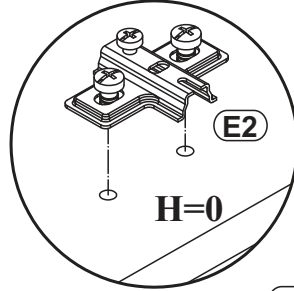
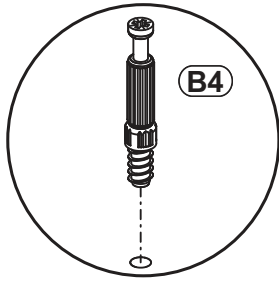
E2		B4	
x3	H=0	x16	

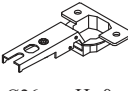

E1		$\text{Ø} 1/32''$
x3	$\text{Ø} 26$	H=0
D10		US09/64"x33/64"
x6		US03,5x13

3

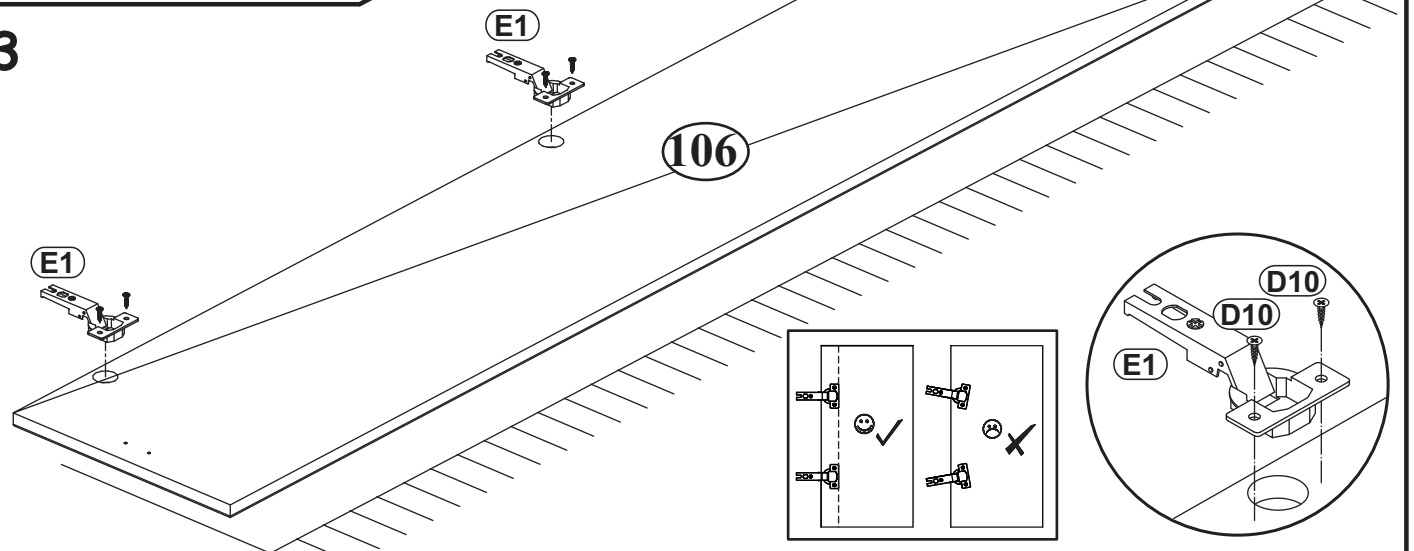



4

a)

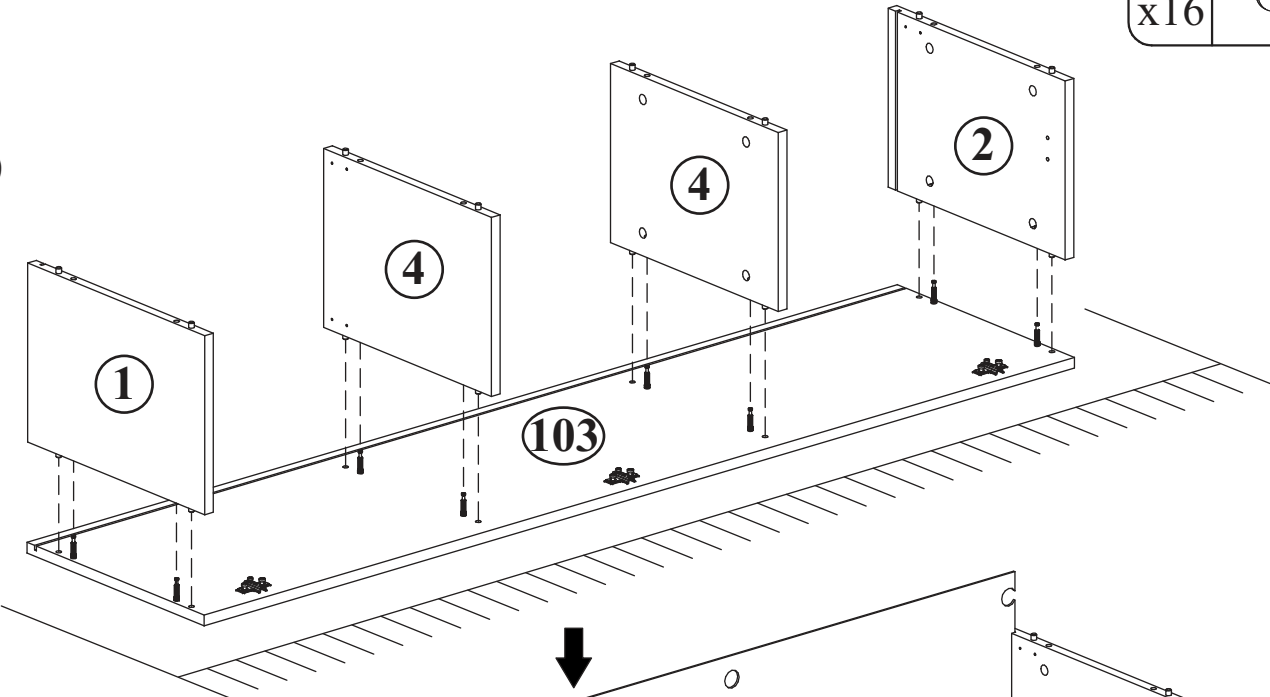

b)

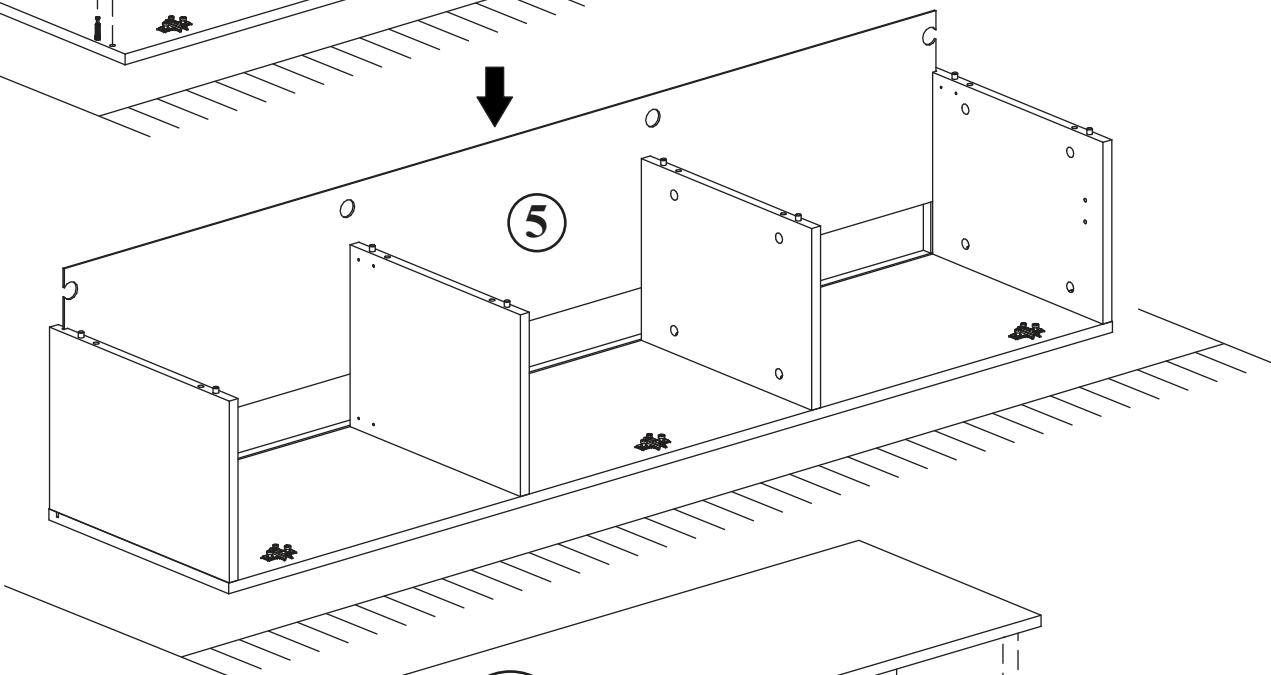

c)

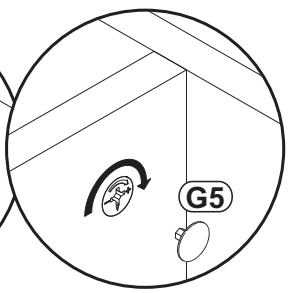
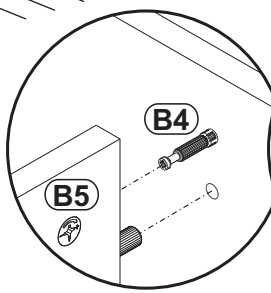
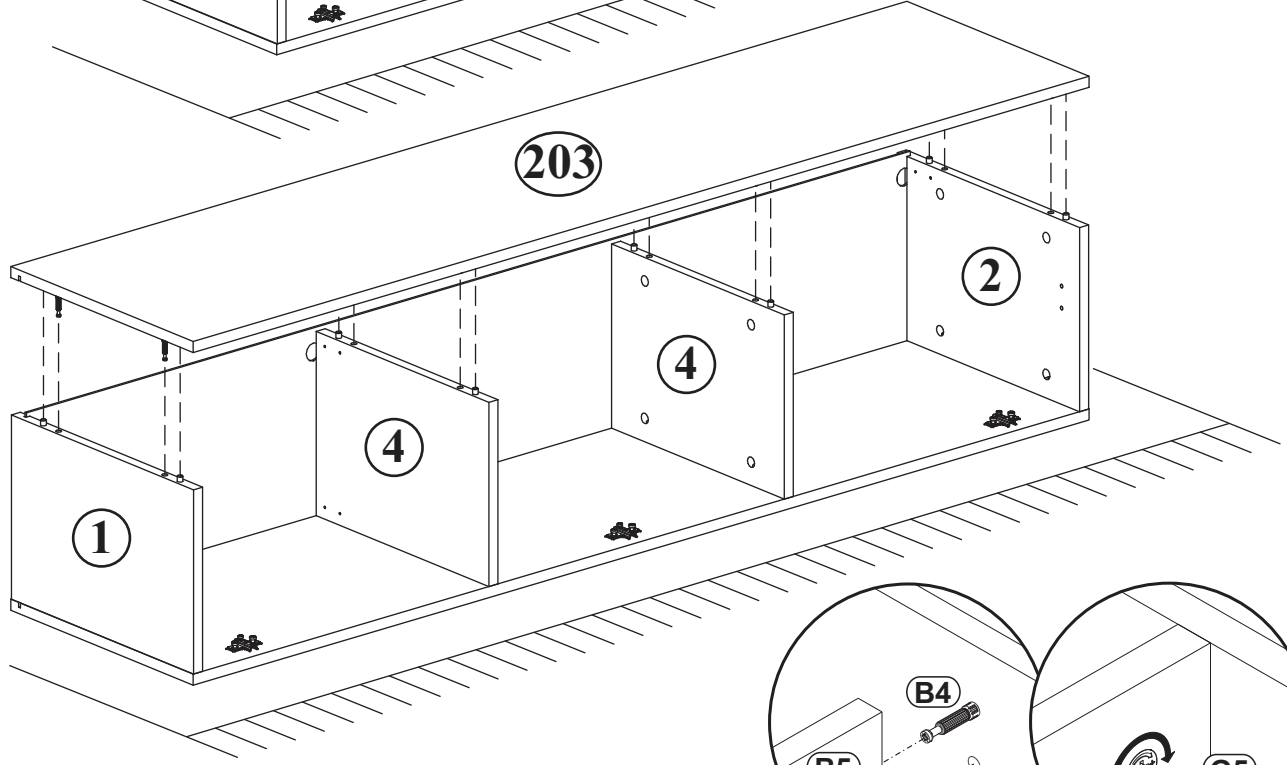

5

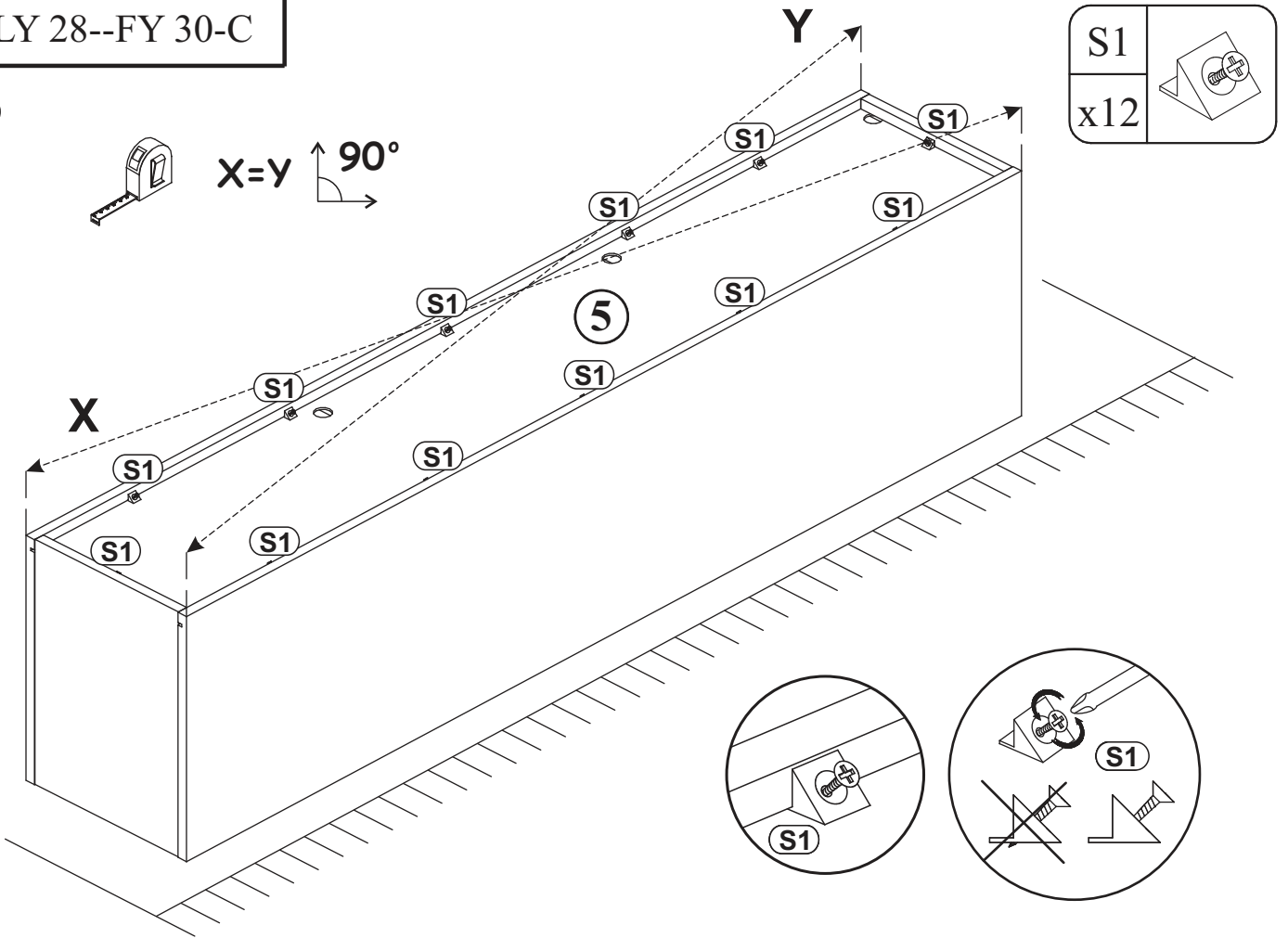

6

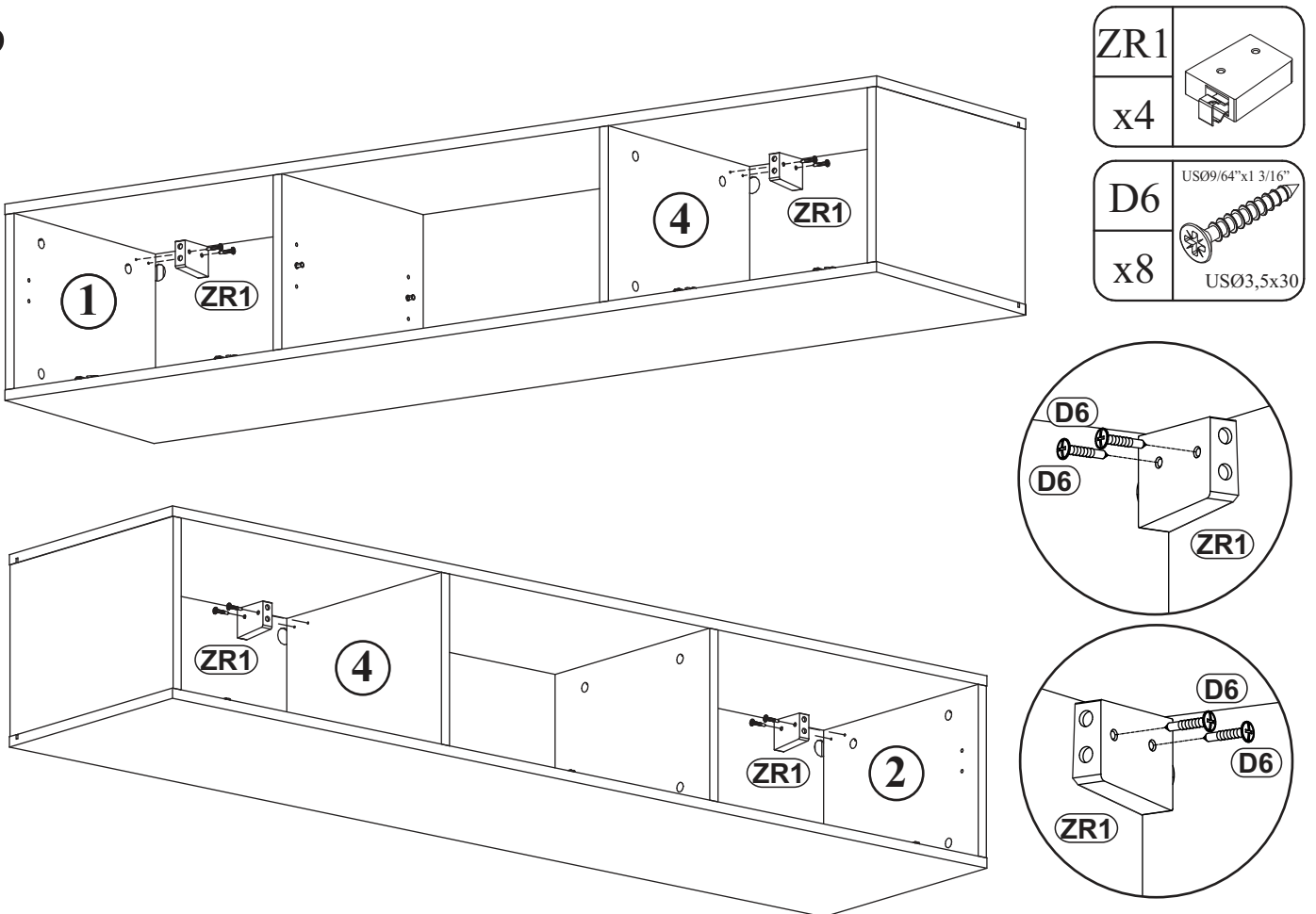

FLY 28--FY 30-C

7

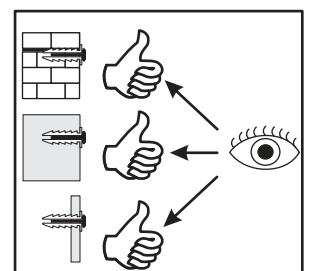
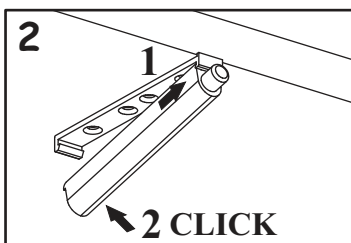
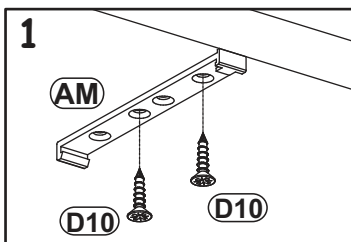
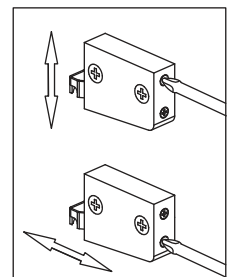
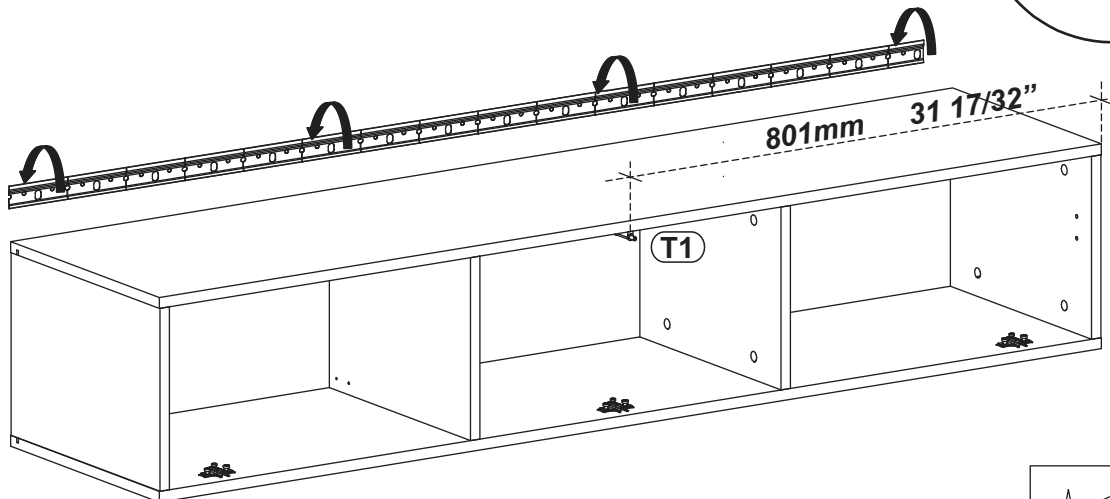
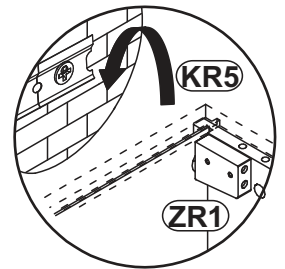
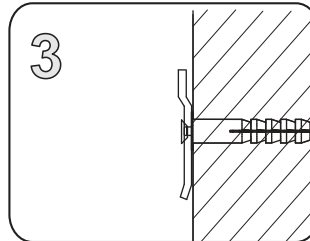
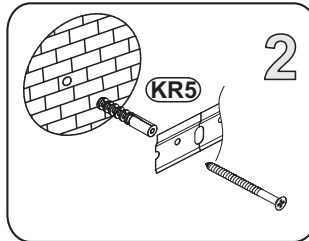
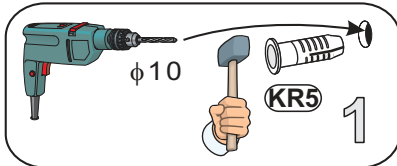
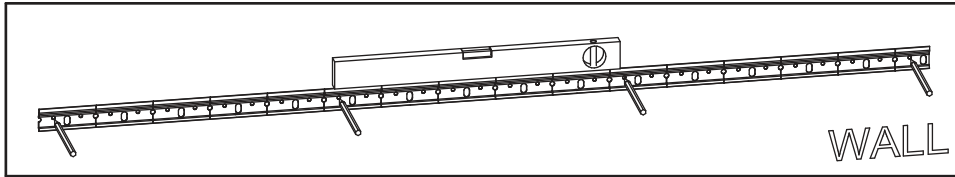
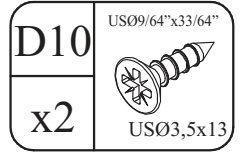
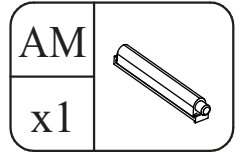
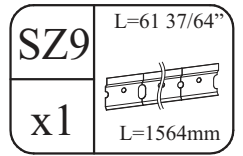
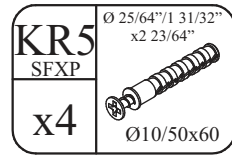
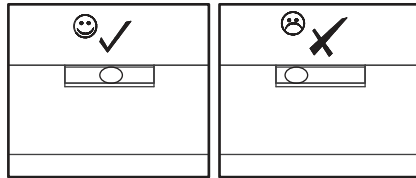

8

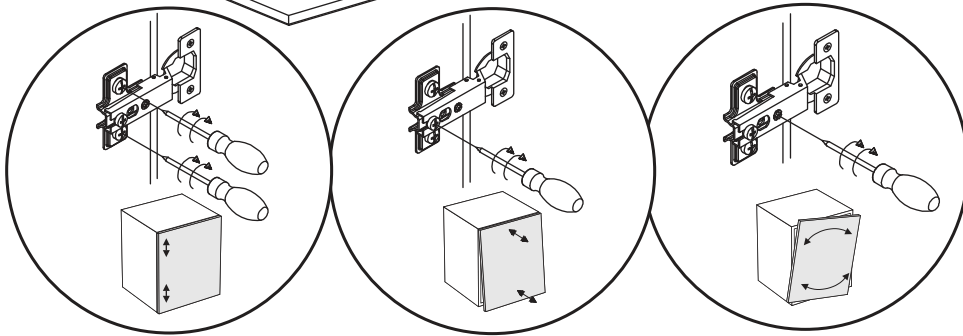
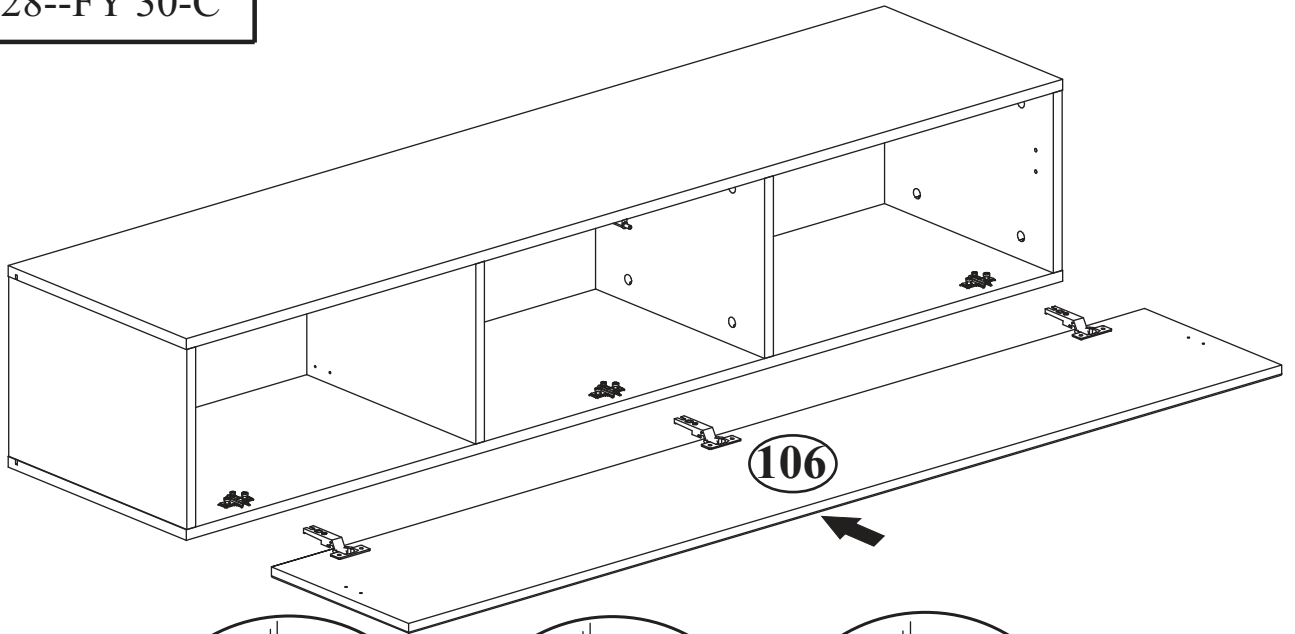

9

