

FLY 28 -- FY 20-C

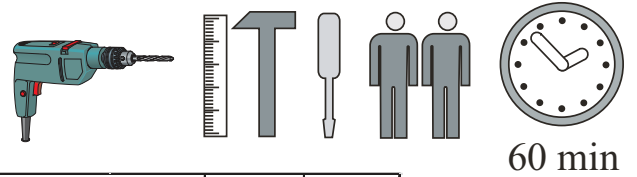

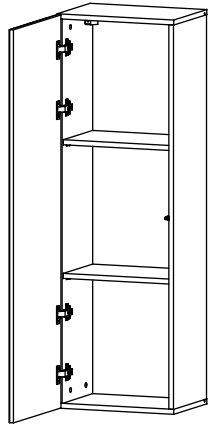

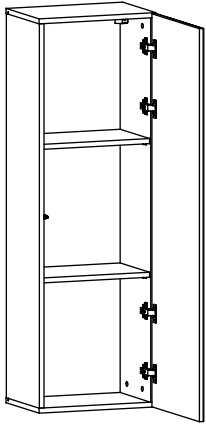

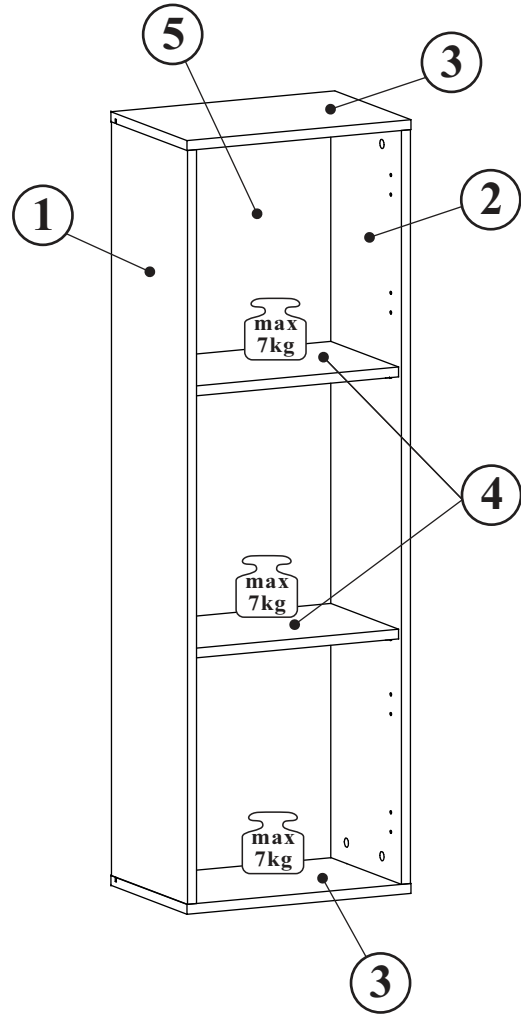
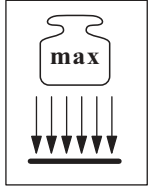
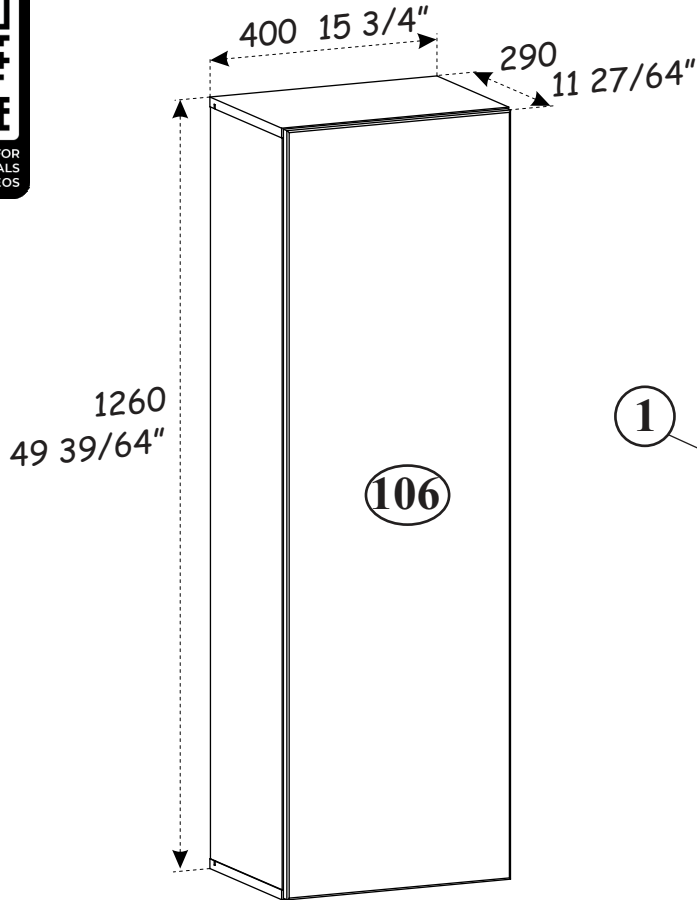
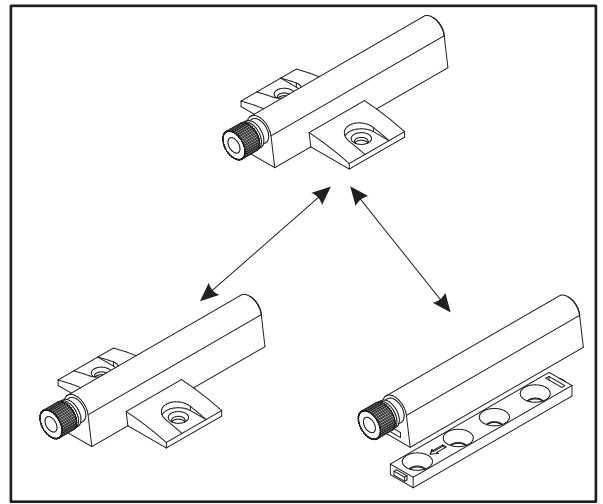
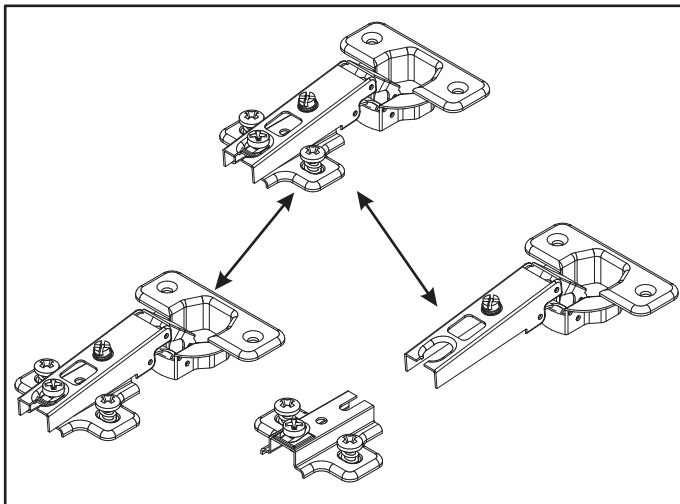
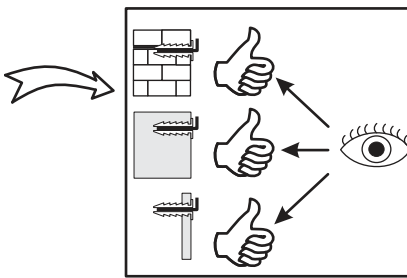
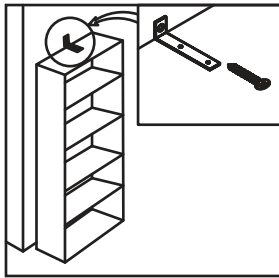
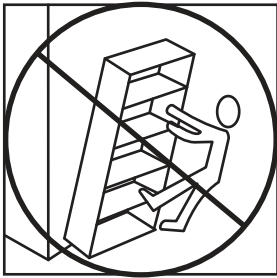
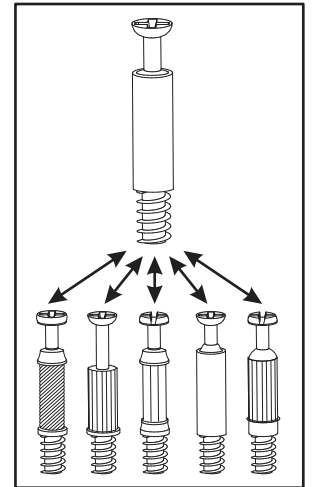
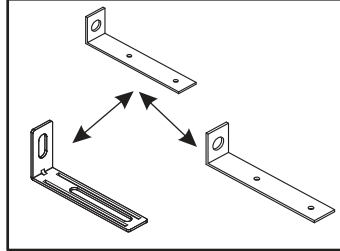
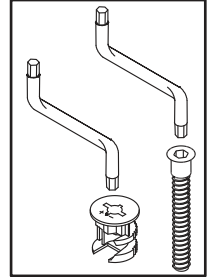
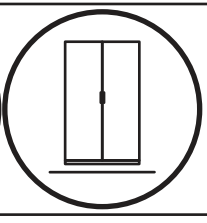
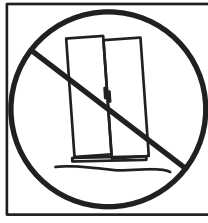
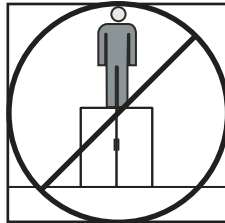
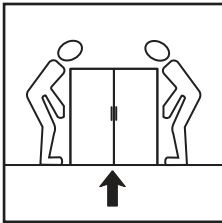
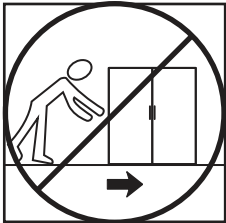
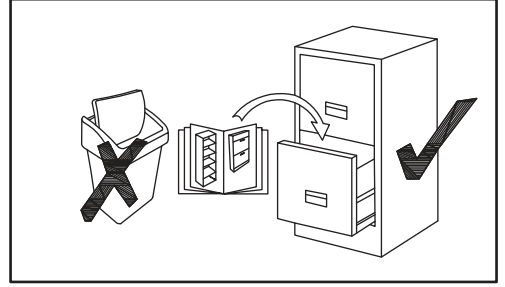
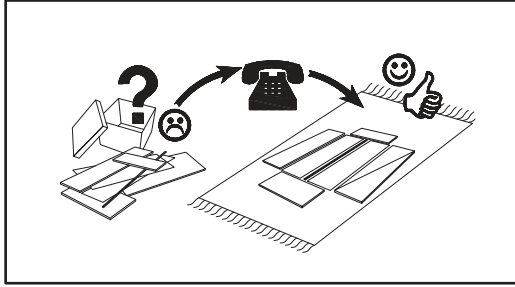
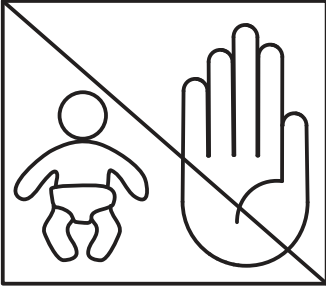
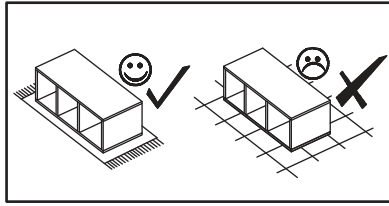
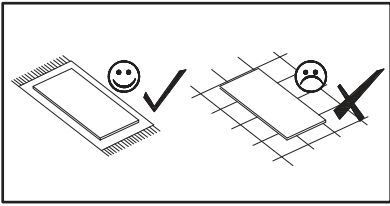



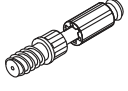

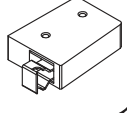

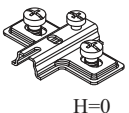
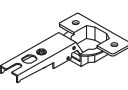
NO	Dim.			Col.-No	Qty
1	1228	274	16	1	1
2	1228	274	16	1	1
3	400	274	16	1	2
4	366	244	16	1	2
5	1240	378	3	1	1
106	394	1256	16	1	1

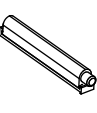
NO	Dim.			Col.-No	Qty
1	48 11/32	10 25/32	5/8	1	1
2	48 11/32	10 25/32	5/8	1	1
3	15 3/4	10 25/32	5/8	1	2
4	14 13/32	9 39/64	5/8	1	2
5	48 13/16	14 7/8	1/8	1	1
106	15 33/64	49 29/64	5/8	1	1

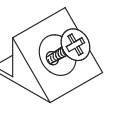

FLY 28--FY 20-C

A1 x8	$\varnothing 5/16 \times 1 27/64$  $\varnothing 8 \times 36$	B4 x8		B5 x8	$\varnothing 19/32 \times 15/32$  $\varnothing 15 \times 12$	G5 x8		ZR1 x2		D6 x4	$US \varnothing 9/64 \times 1 3/16$  $US \varnothing 3,5 \times 30$
E2 x4	 H=0	E1 x4	$\varnothing 1 1/32$  $\varnothing 26$ H=0	D10 x10	$US \varnothing 9/64 \times 33/64$  $US \varnothing 3,5 \times 13$	AM x1		G7 x8		Z2 x8	 $\varnothing 5$
S1 x10		KR5 SFXP x1	$\varnothing 25/64 \times 1 31/32$ $\times 2 23/64$  $\varnothing 10/50 \times 60$	SZ9 x1	$L=14 1/4$  $L=362\text{mm}$	G2 x1					

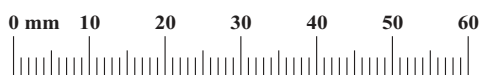
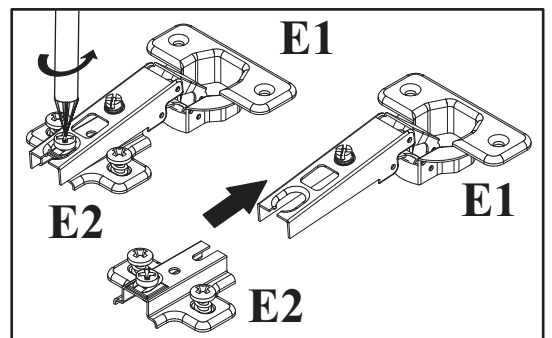

A1	Ø5/16"x1 27/64"
x8	 ø8x36

B5	Ø19/32"x15/32"
x8	 ø15x12

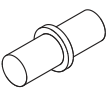
G7	
x8	

1

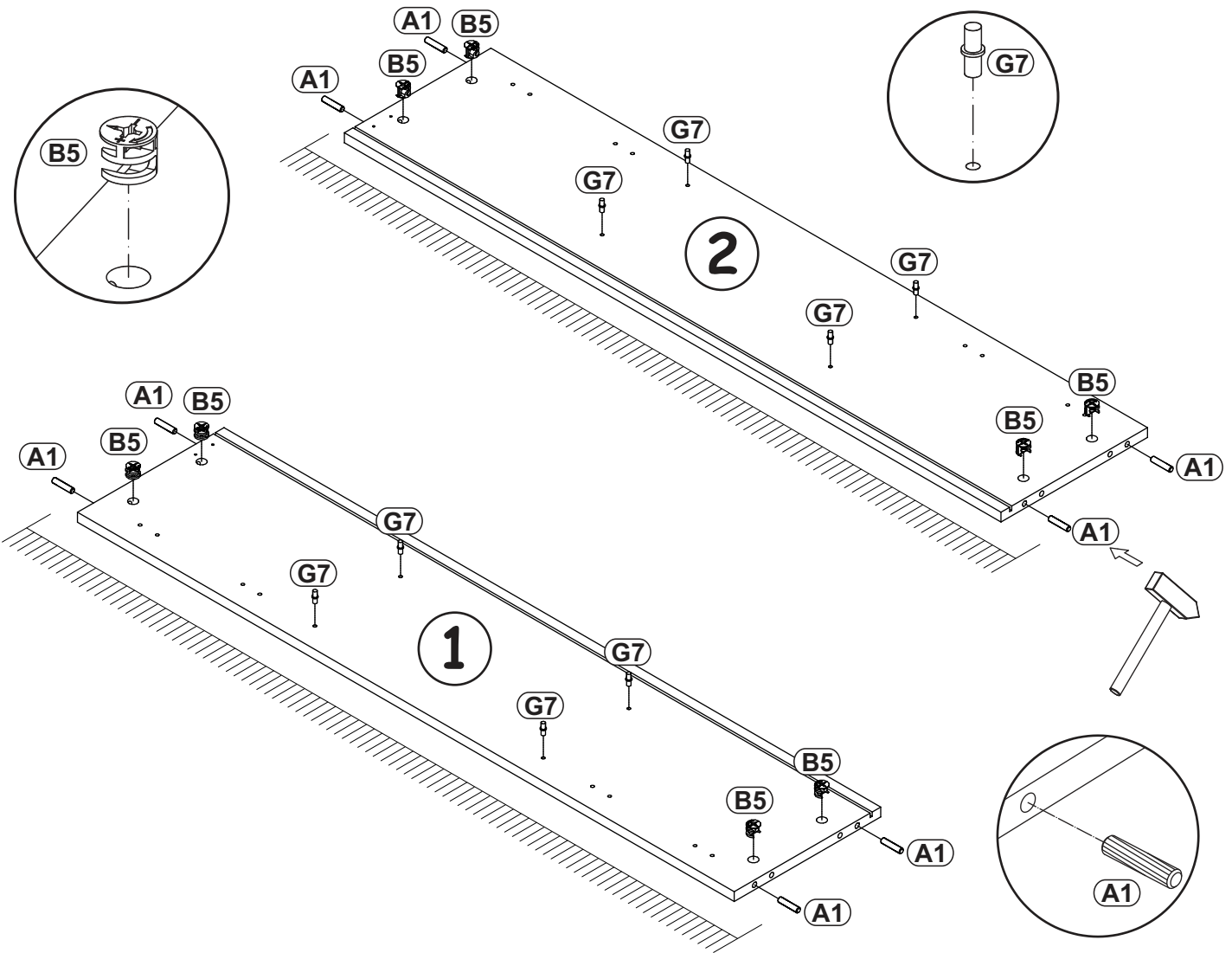

2

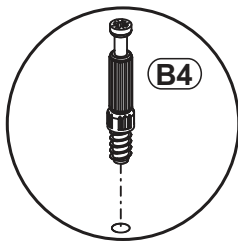

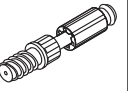
B4	
x8	

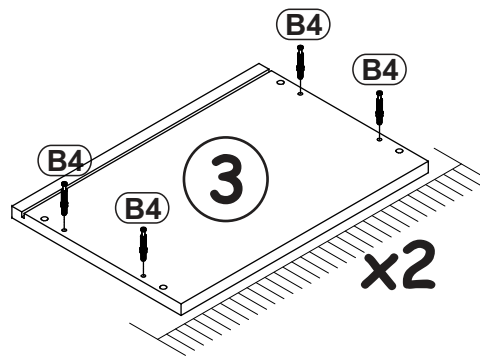

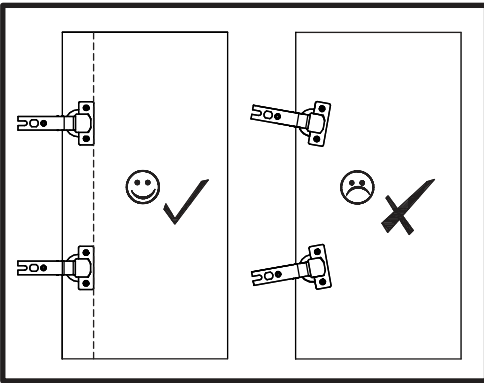
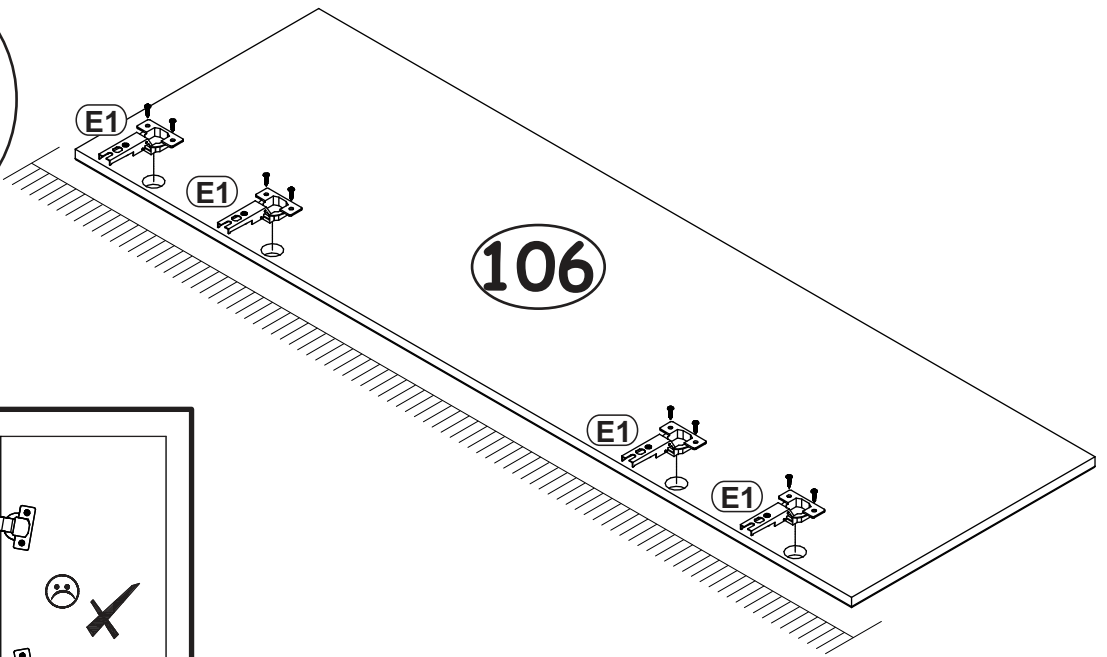
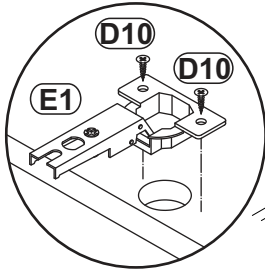
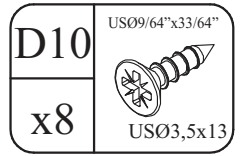
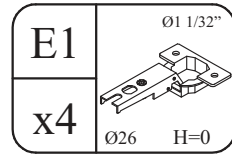
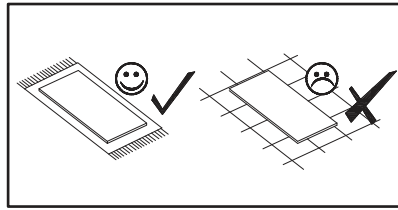

FLY 28--FY 20-C

3

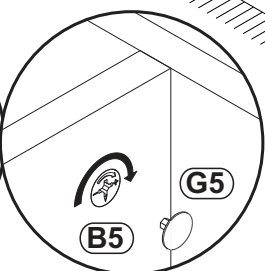
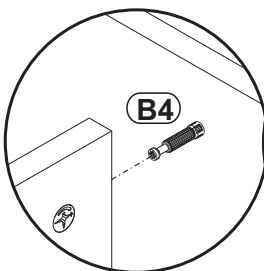
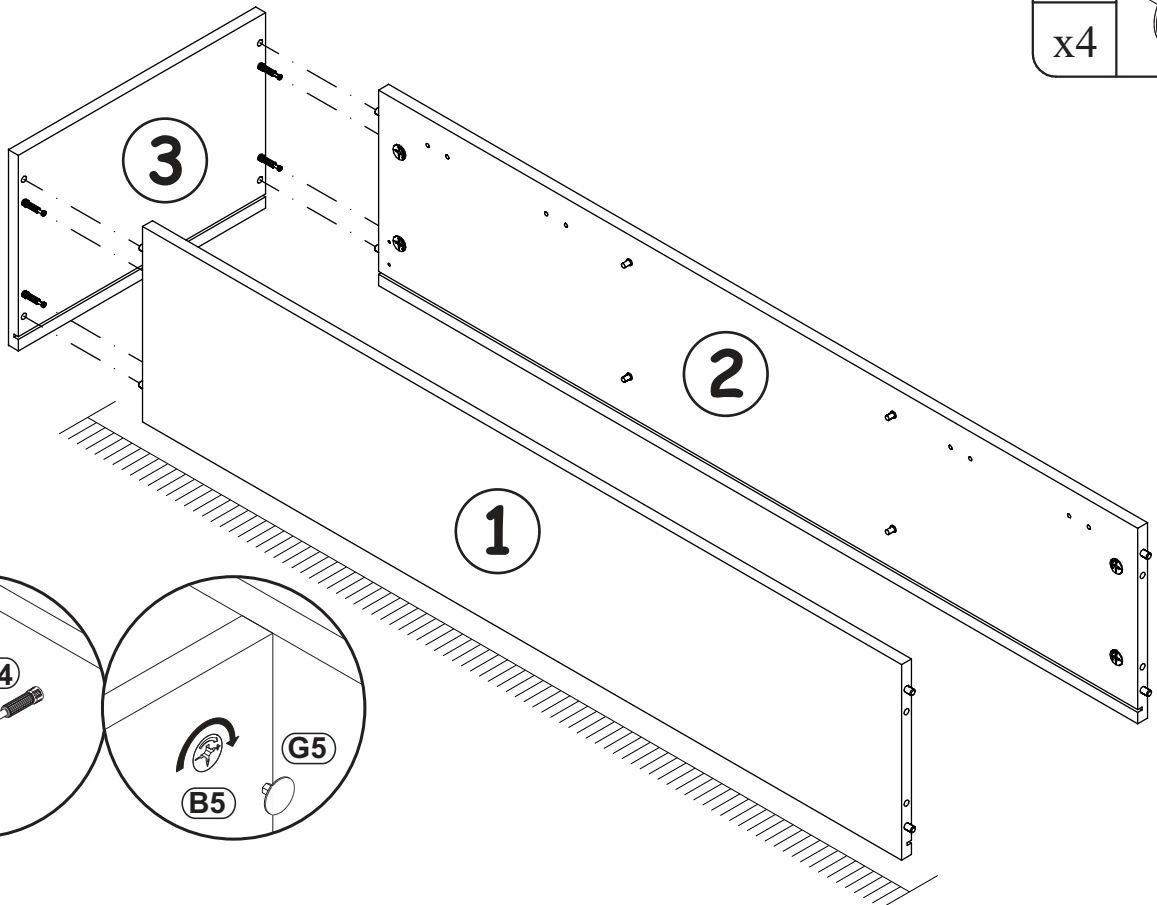
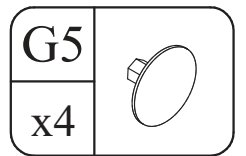

4



G5	
x4	

5

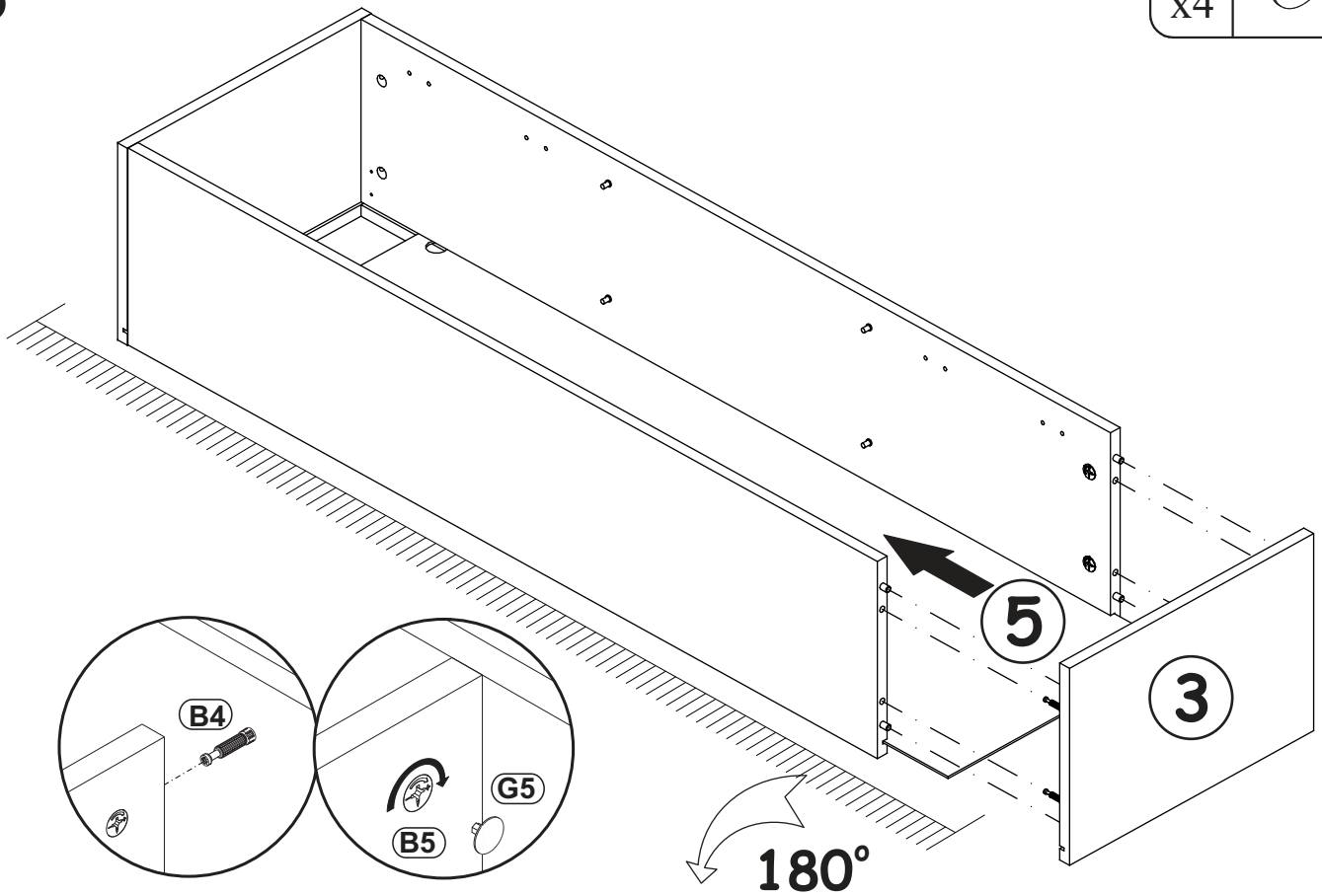

6

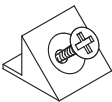

S1	
x10	

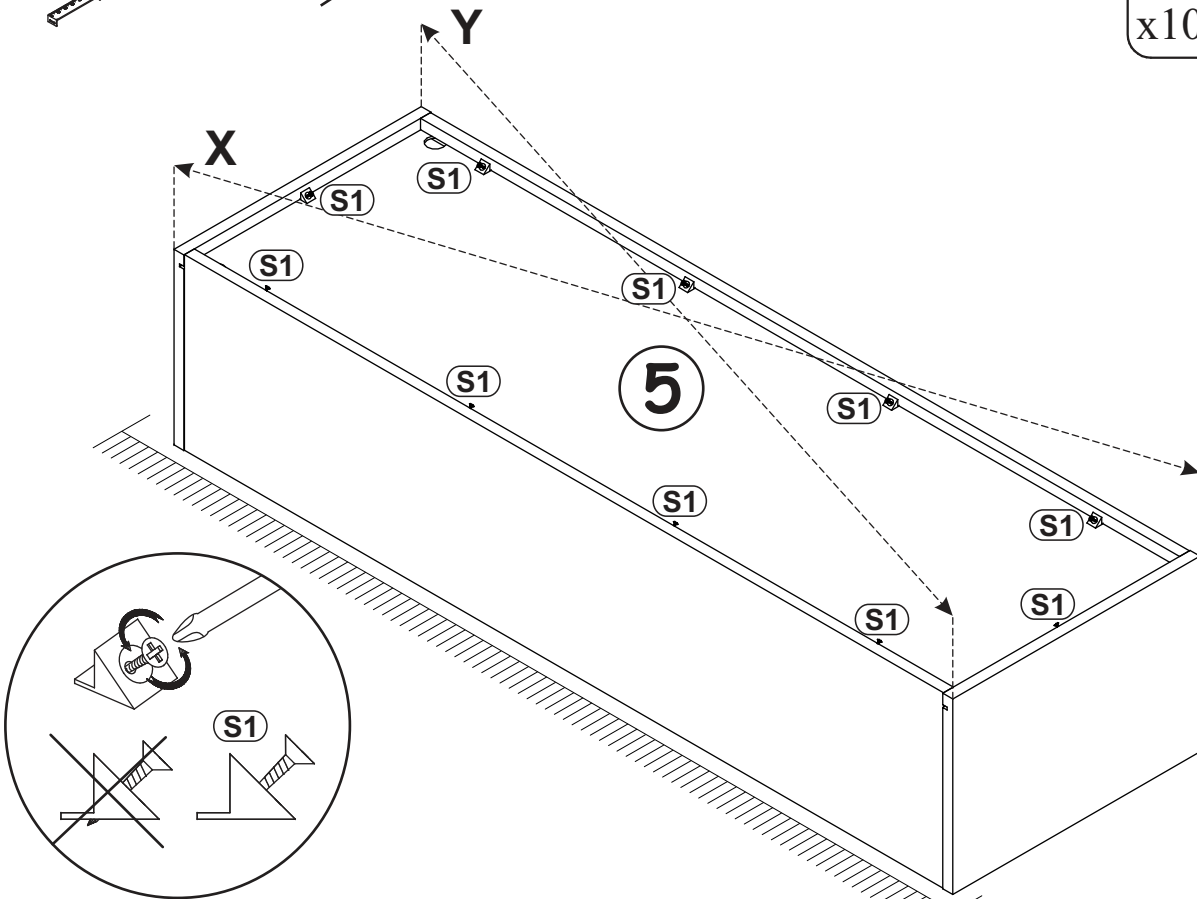

FLY 28--FY 20-C

7

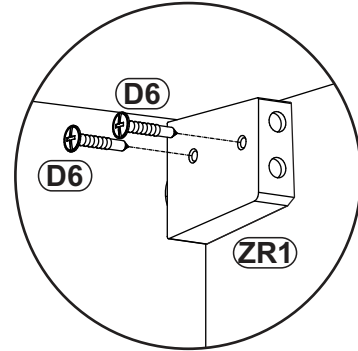
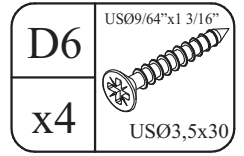
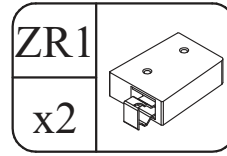
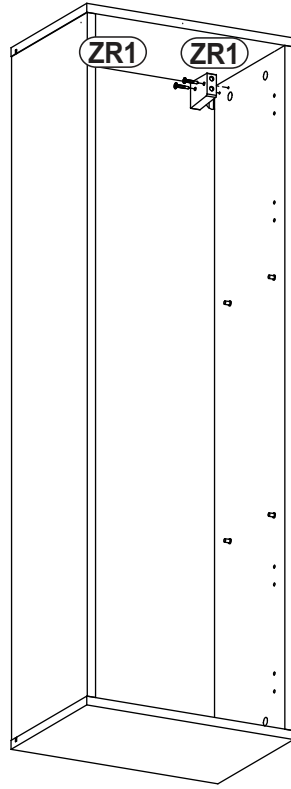
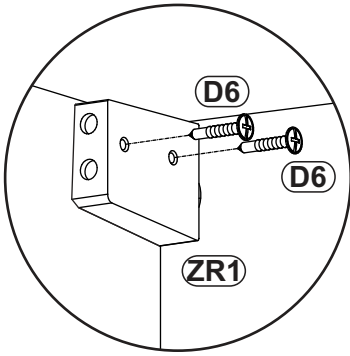

8

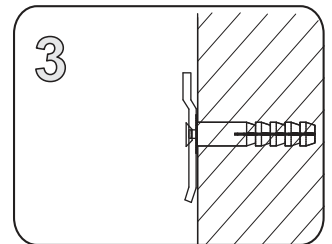
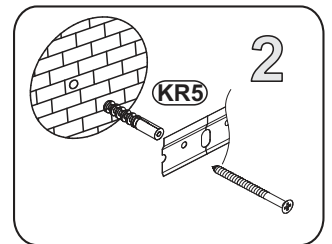
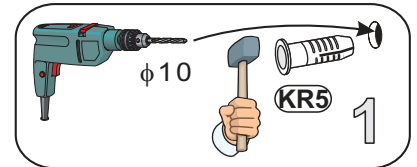
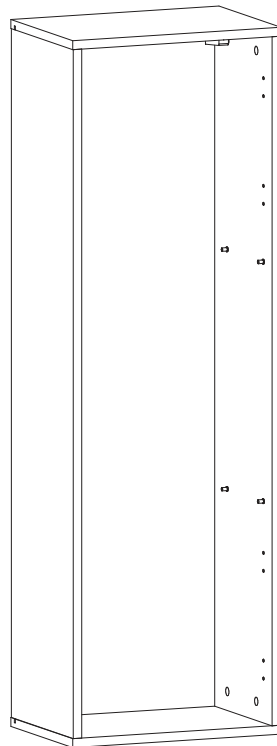
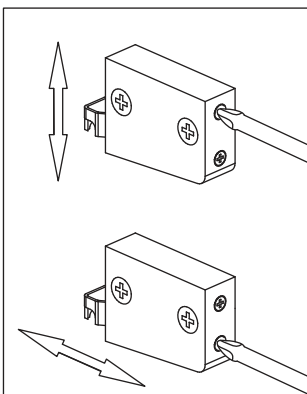
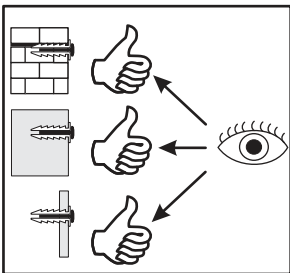
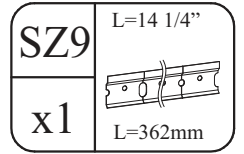
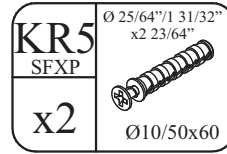
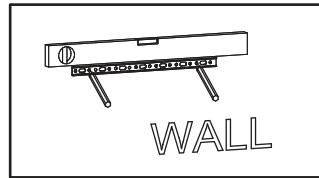
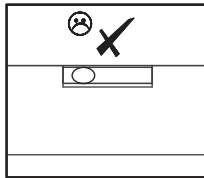
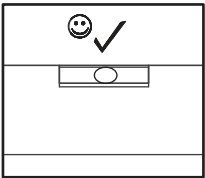

9-10

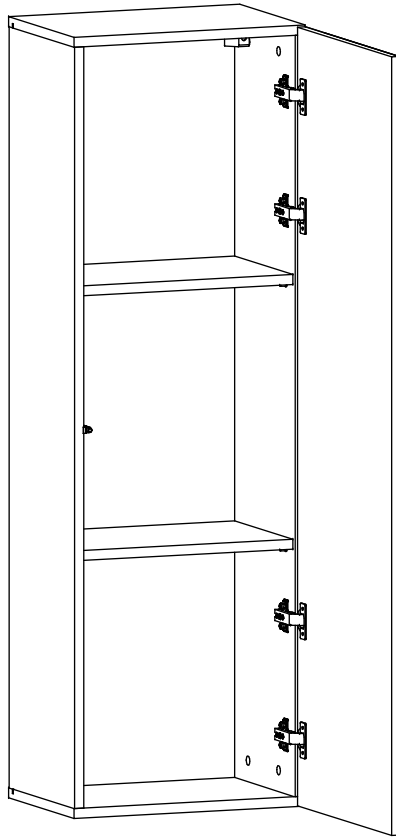

11-12

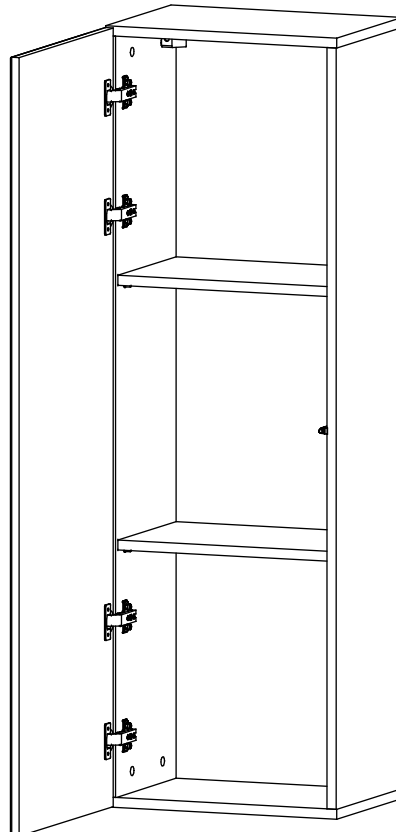

9

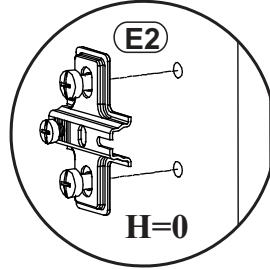
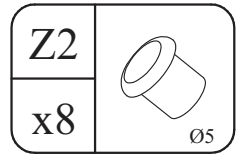
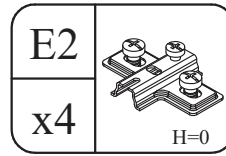
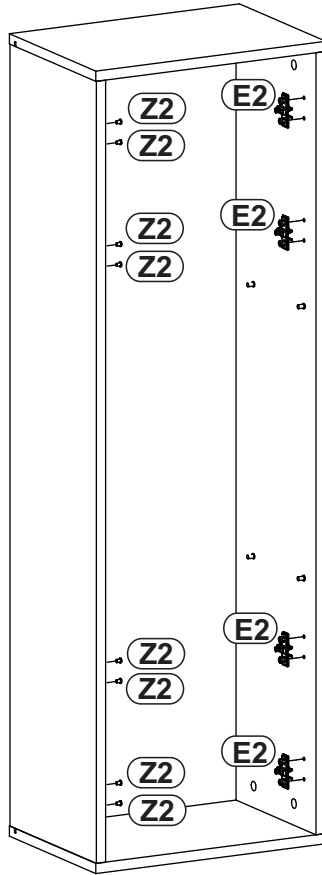
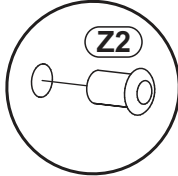
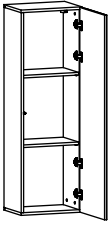

10

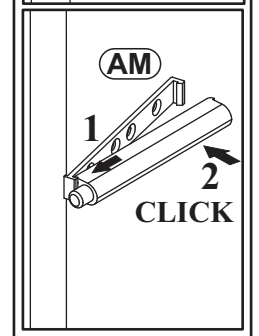
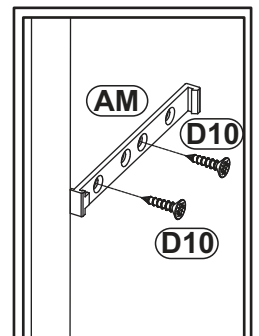
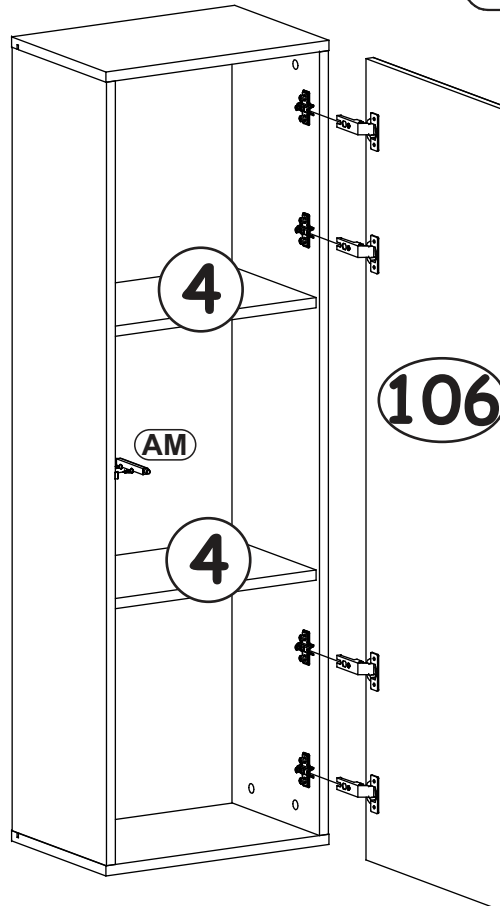
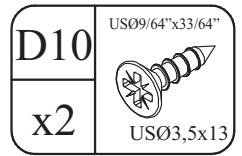
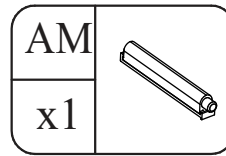
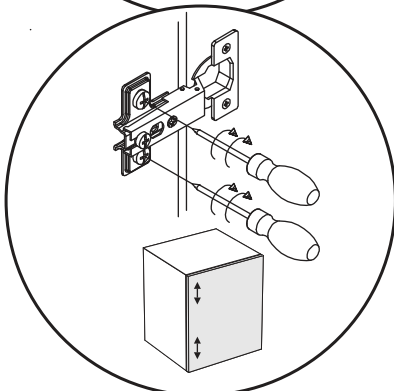
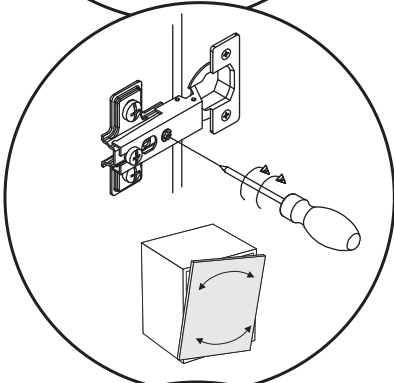
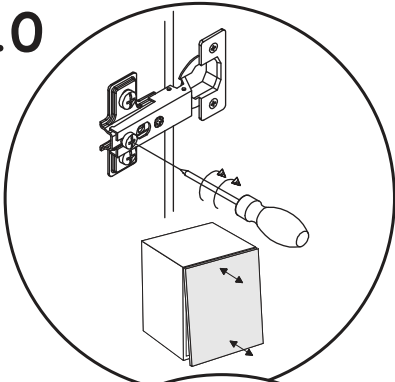

11

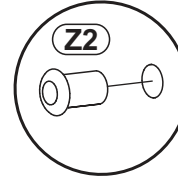
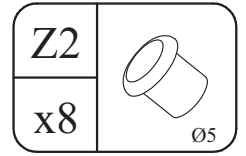
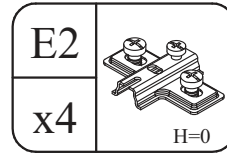
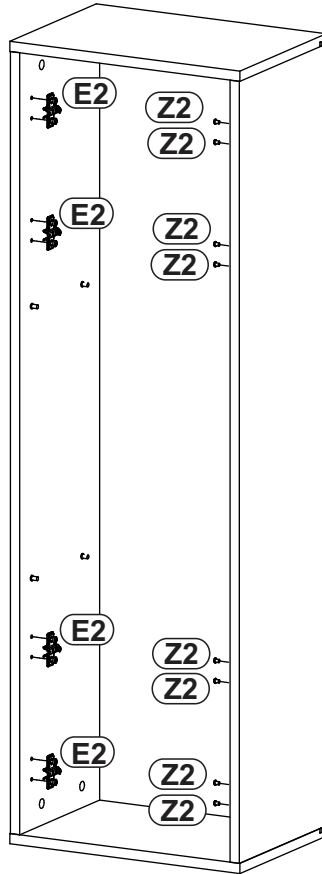
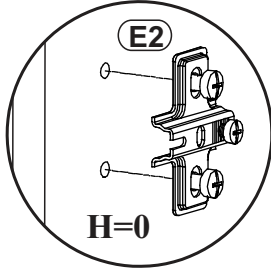
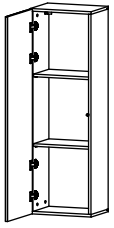

12

