

PL- Przed rozpoczęciem zapoznać się z instrukcją montażu/ DE- Vor die montage, bitte beiliegende anweisungen folgen/
EN- Before starting, refer to the assembling advice in annex/ CZ- Před zahájením naleznete v montážním návodu/ HR- Prije početka, uzmite upute za montažu u prilogu

EVORA RTV

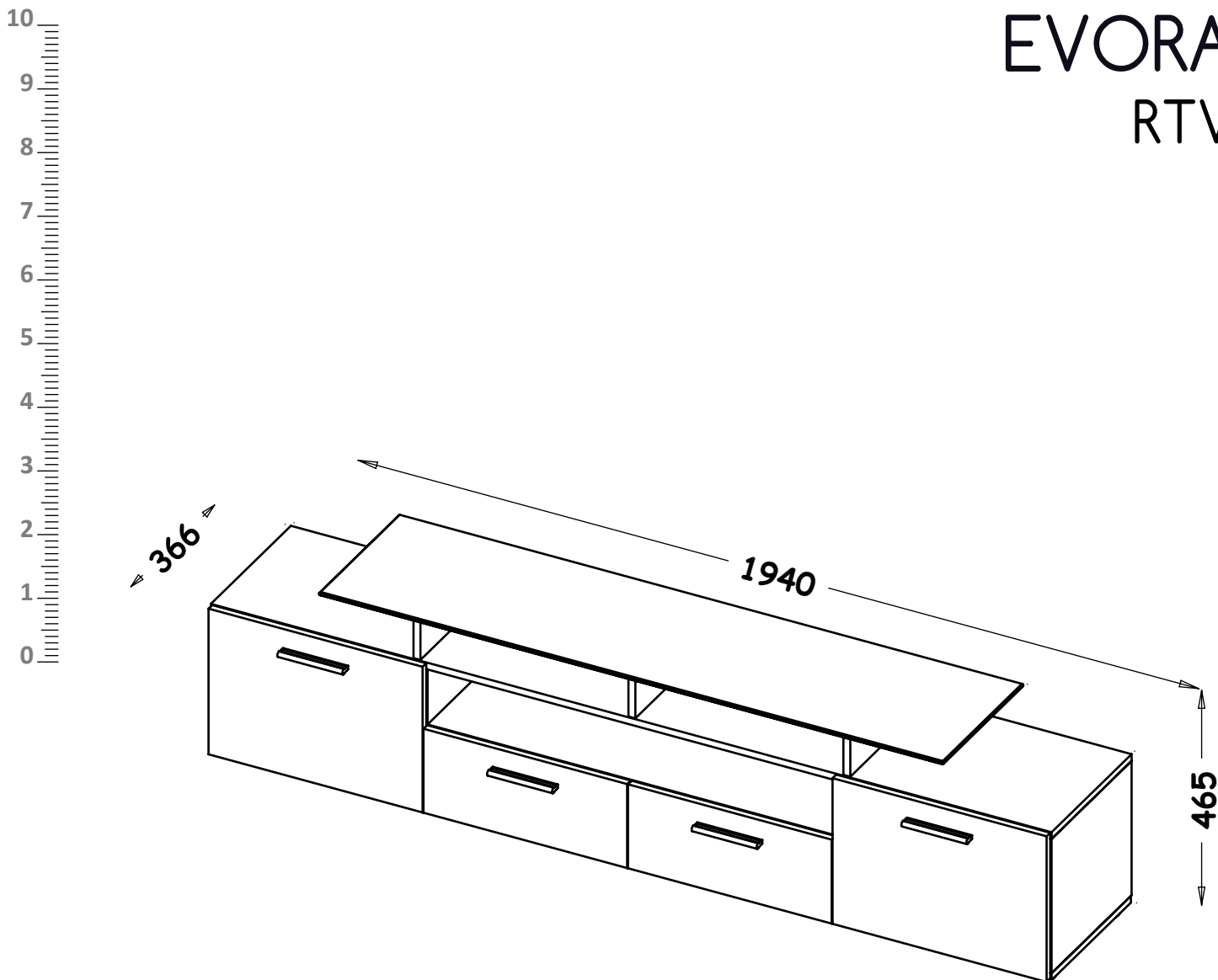

PL- Narzędzia niezbędne do montażu (nie dostarczone przez producenta)/ DE- Für die Montage notwendige Werkzeuge (nicht vom Hersteller mitgeliefert)/ EN- Tools required for assembly (not provided by the manufacturer)/ CZ- Nástroje nezbytné pro montáž (nejsou dodávány výrobcem)/ HR- Alat potreban za montažu (nije osiguran od strane proizvođača)

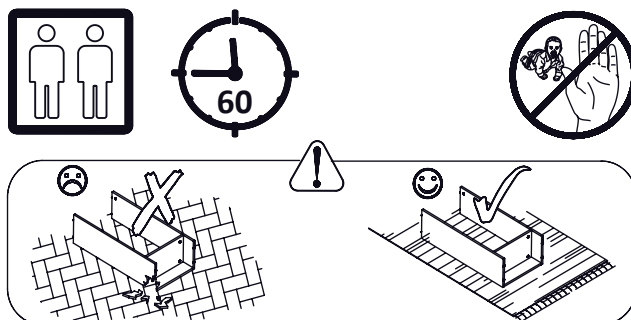
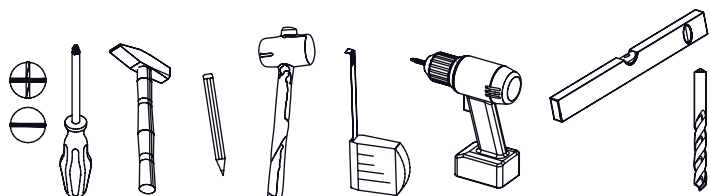



PL - UWAGA!

W przypadku reklamacji prosimy o podanie numeru serii znajdującego się na kartonie. W związku z tym prosimy o zachowanie opakowań do momentu zmontowania mebla. W przypadku stwierdzenia uszkodzenia któregoś z elementów, prosimy nie montować modułu, którego częścią jest dany element.

DE - HINWEIS!

Im Falle einer Reklamation geben Sie bitte die Seriennummer, die sich auf der Verpackung befindet. Daher bitten wir Sie immer die Verpackung solange aufzubewahren, bis die Möbelstücke vollständig montiert sind. Sollten Schäden an Einzelteilen auftreten, bitte sehen Sie von der Montage des Moduls ab.

EN - ATTENTION!

In case of claim please give us series number which you can find on the box. Thereupon please keep the package until montage of furniture is done. In case verified damage any of elements, please do not mount module, which is a parts of particular element.

CZ - POZOR!

Při reklamaci prosíme o uvedení čísla šarže, které se nachází na obale. V souvislosti s tímto prosíme o uchování obalů do okamžiku složení nábytku. V případě poškození některého z dílů, prosíme neskládat model, jehož součástí poškozený díl je.

HR - PAŽNJA!

U slučaju reklamacije, molimo Vas da nam date serijski broj koji možete pronaći na ambalaži. Molimo Vas da zadržite ambalažu sve dok nije kompletna montaža proizvoda. Ukoliko je uočeno oštećenje bilo kojeg elementa, molim Vas da ne montirate oštećeni dio.

Nr	Xmm	Ymm	Zmm	x
1	1940	350	16	1
2	1940	347	16	1
3	320	350	16	1
4	320	347	16	1
5	320	347	16	1
6	320	350	16	1
7	940	347	16	1
8	90	347	16	3
9	1928	345	2,5	1
10	420	300	2,5	2
11	404	130	16	2
12	300	150	16	2
13	300	150	16	2
14	470	200	16	1
15	347	494	16	2
17	470	200	16	1
18	173	347	16	1
19	1440	350	8	1

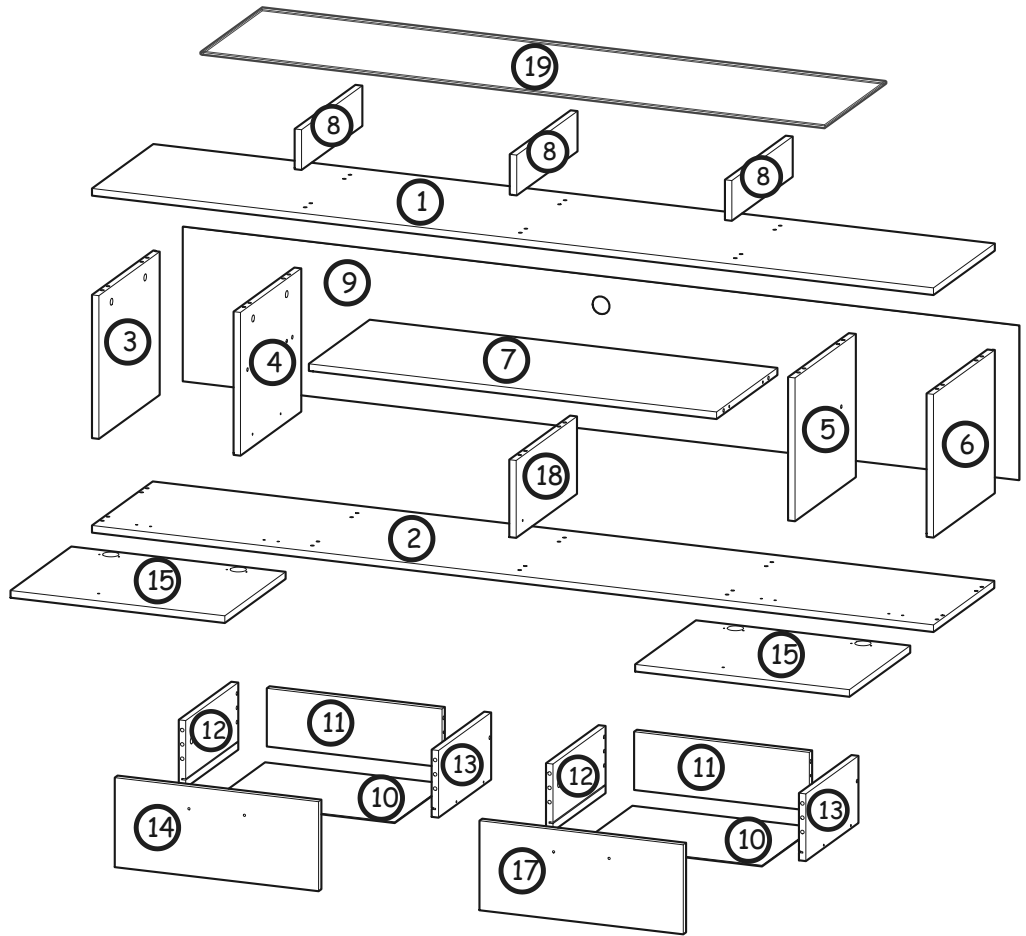

W4 70x 	W3 6x 	P19 8x Ø44x15 	G12 8x 4x25 	E21 4x R192 	G16 8x Ø4x27
A1 24x Ø7x50 	I12 10x Ø4/Ø11 	B1 46x Ø8x35 	K5 14x 34mm 	K1 14x Ø15x12 	I20 14x Ø4/Ø17
H6 2x L300 	G20 8x Ø5x13 	G21 8x 3x16 	D3 4x PZ35PR 	G5 8x 4x13 	C3 4x Z35PR
W2 1x 4mm 					

I

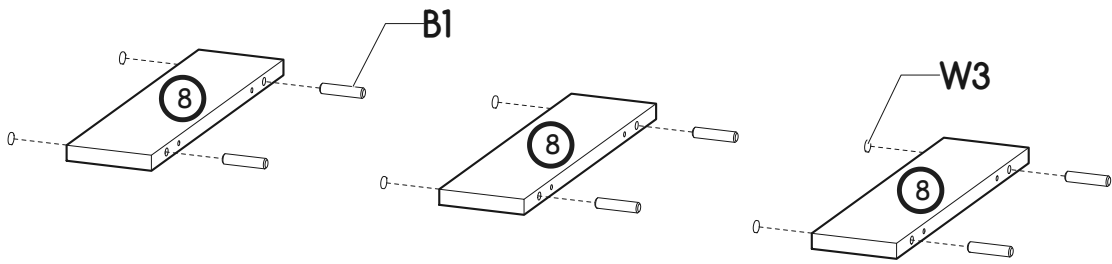
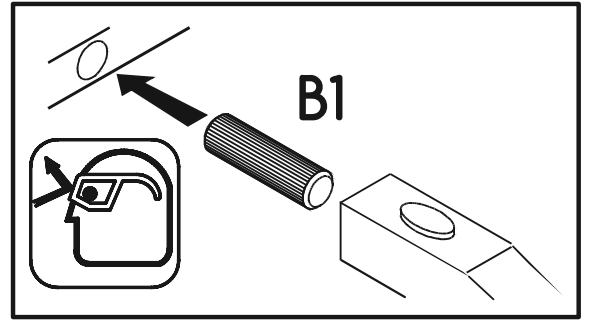

II

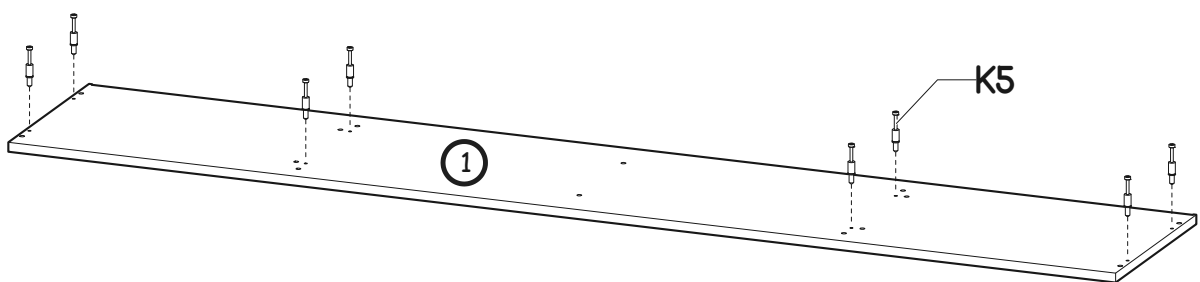
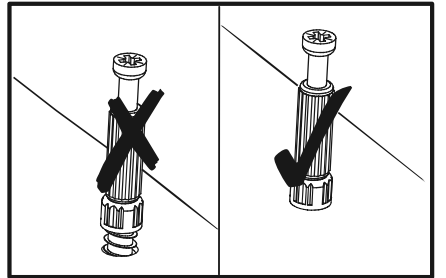
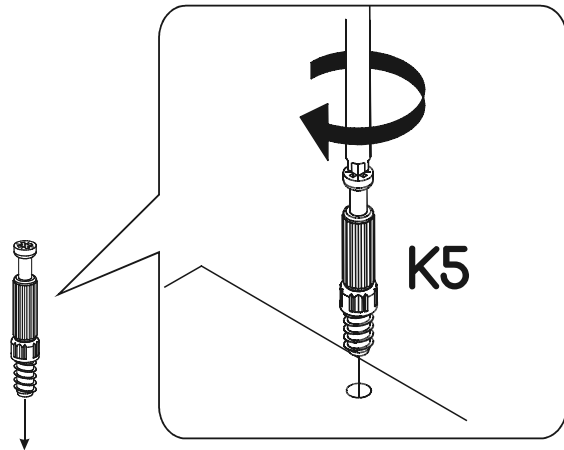

III

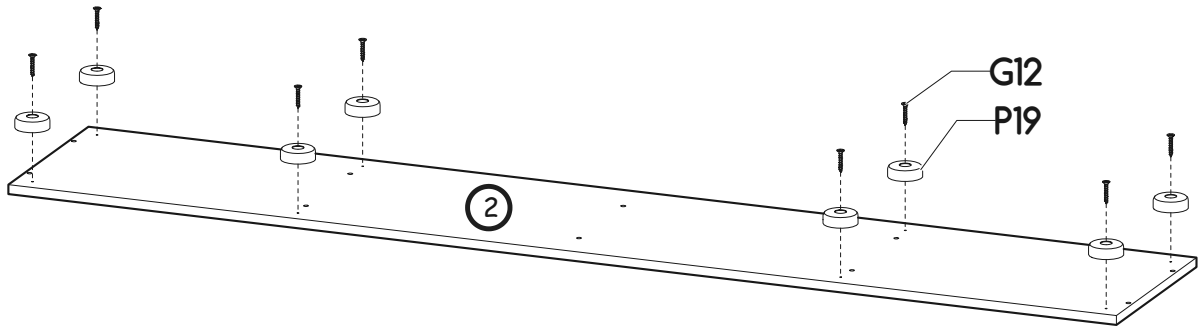

180°

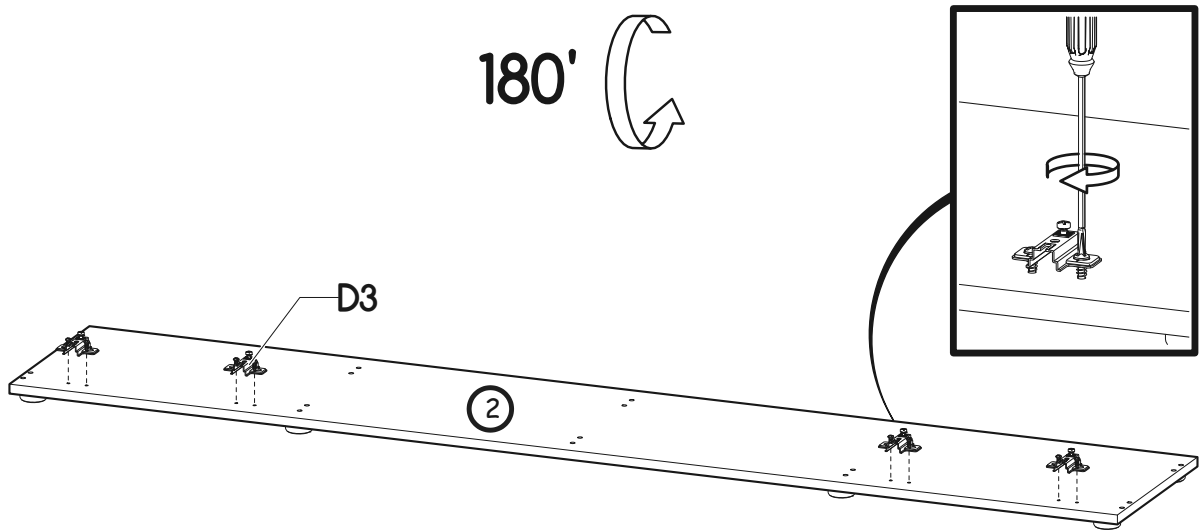

IV

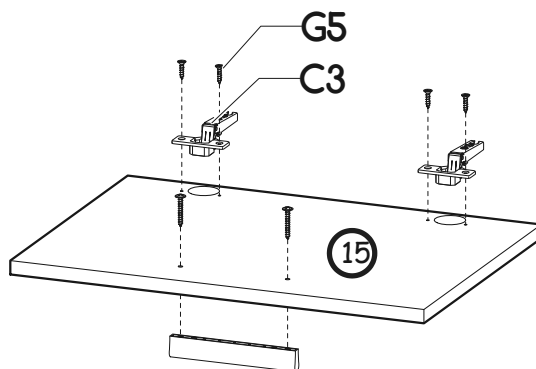
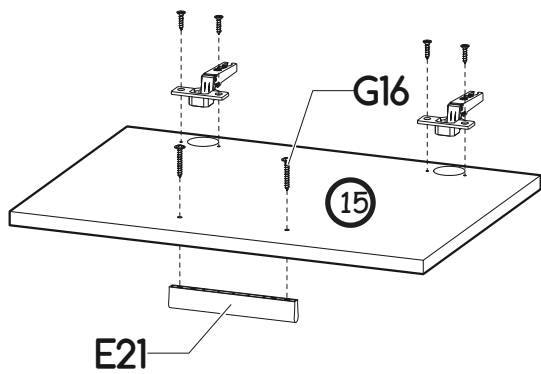
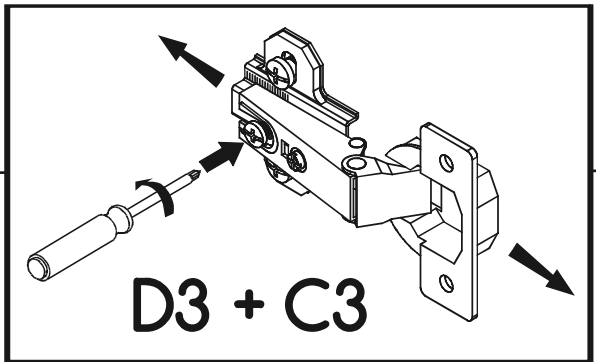

V

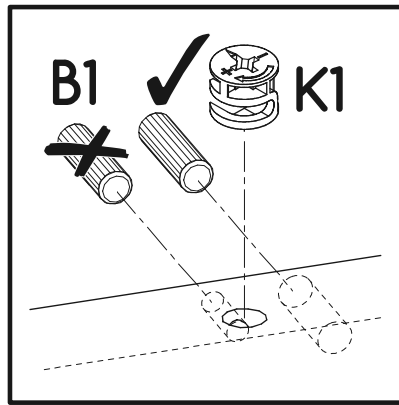
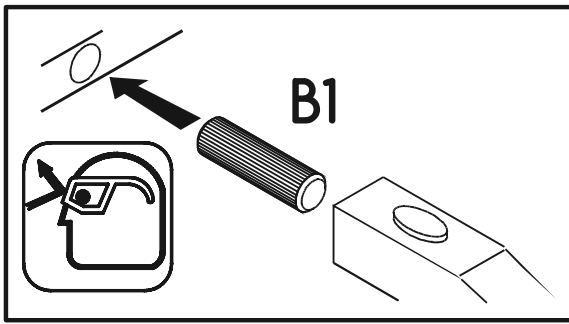
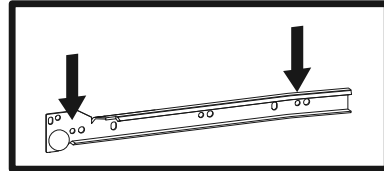
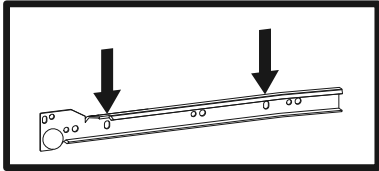
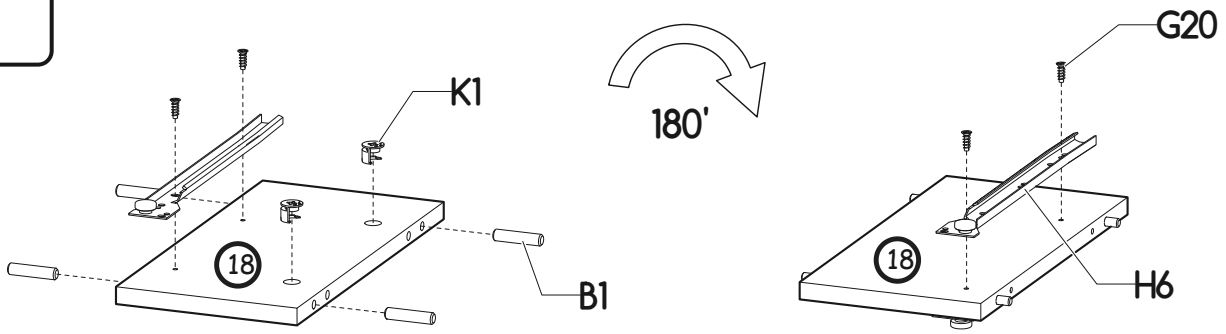

VI

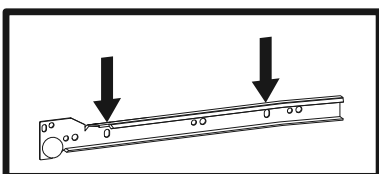
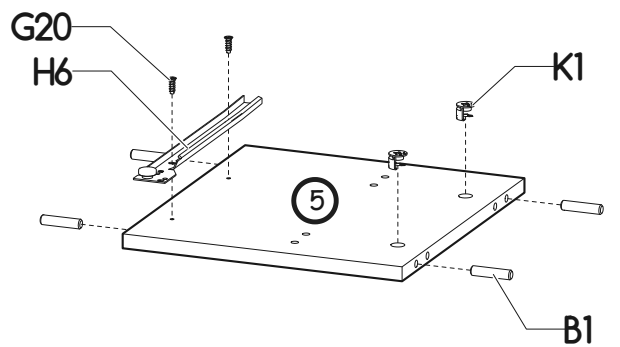
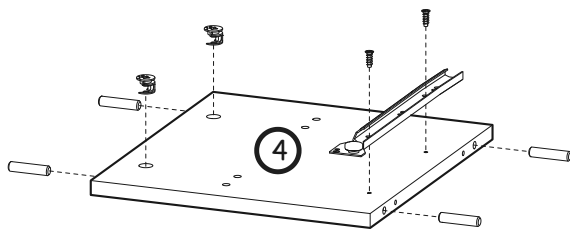
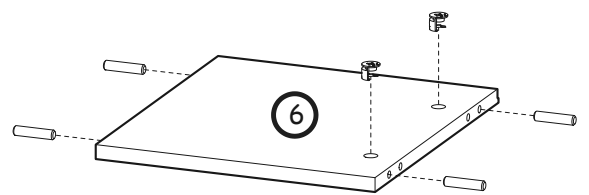
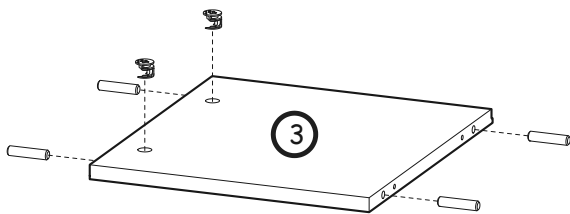

VII

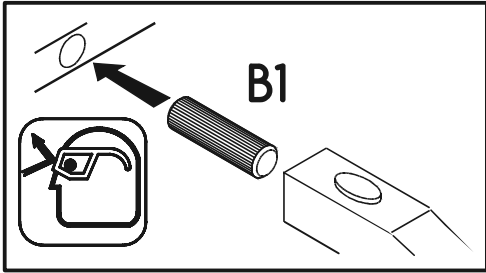
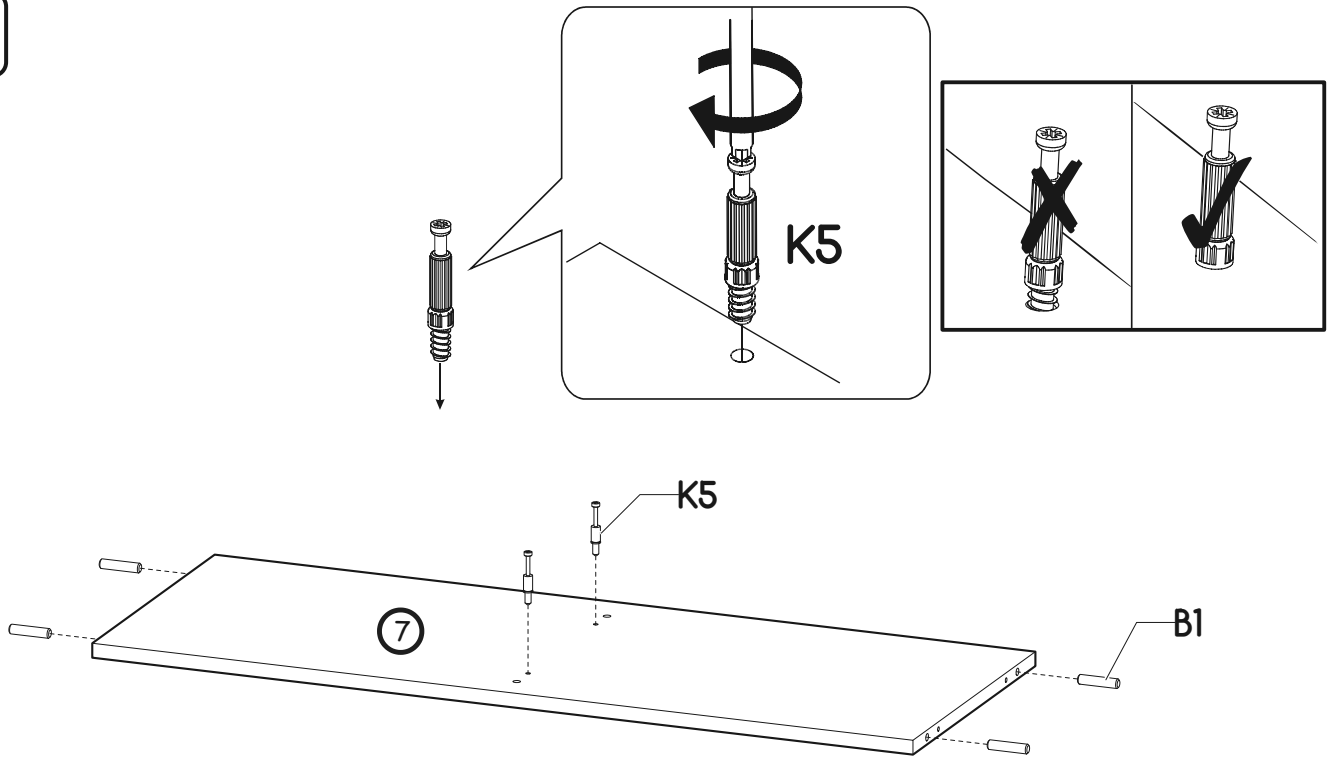

VIII

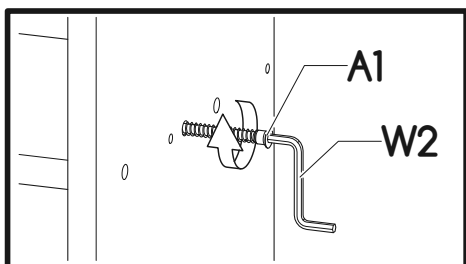
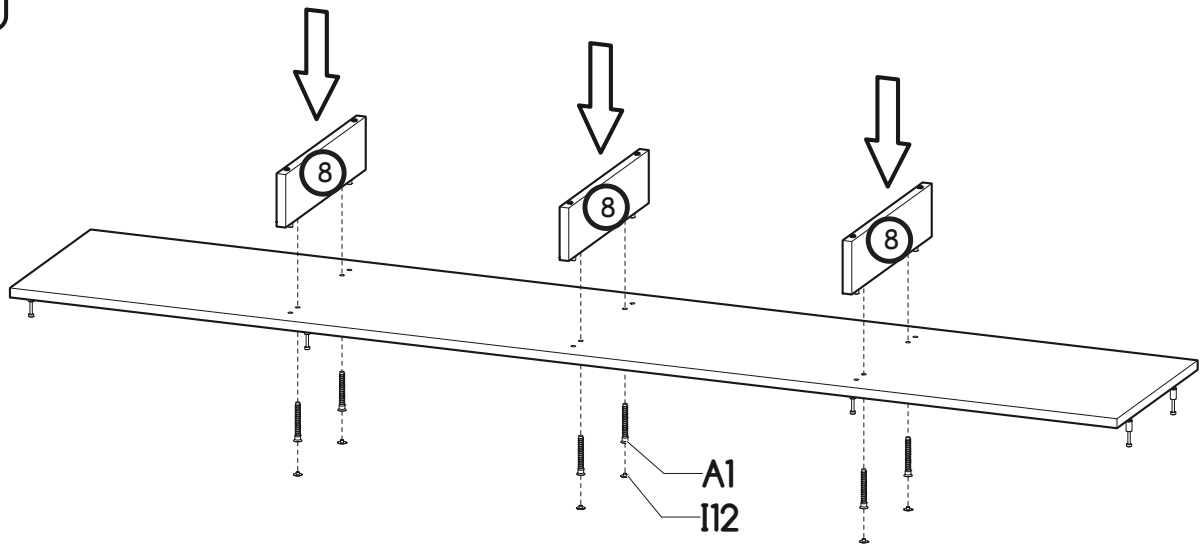

IX

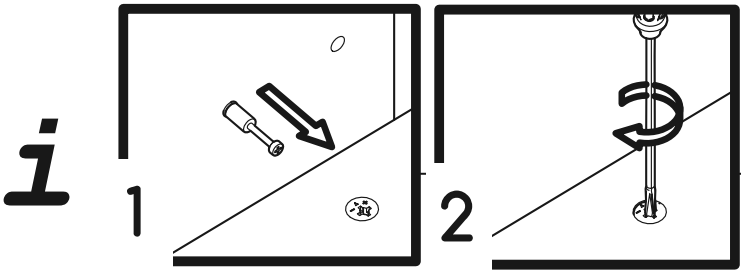
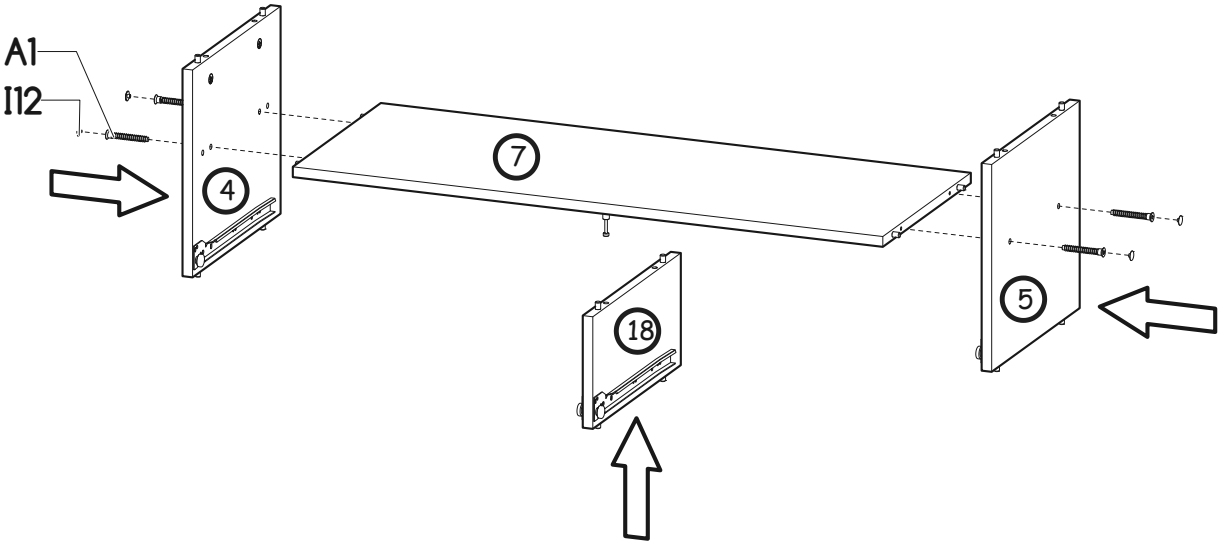
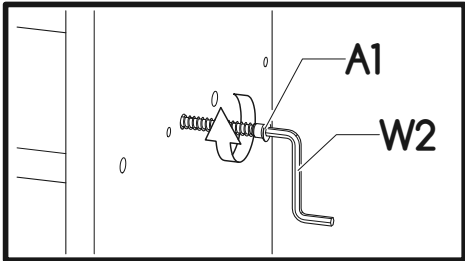

X

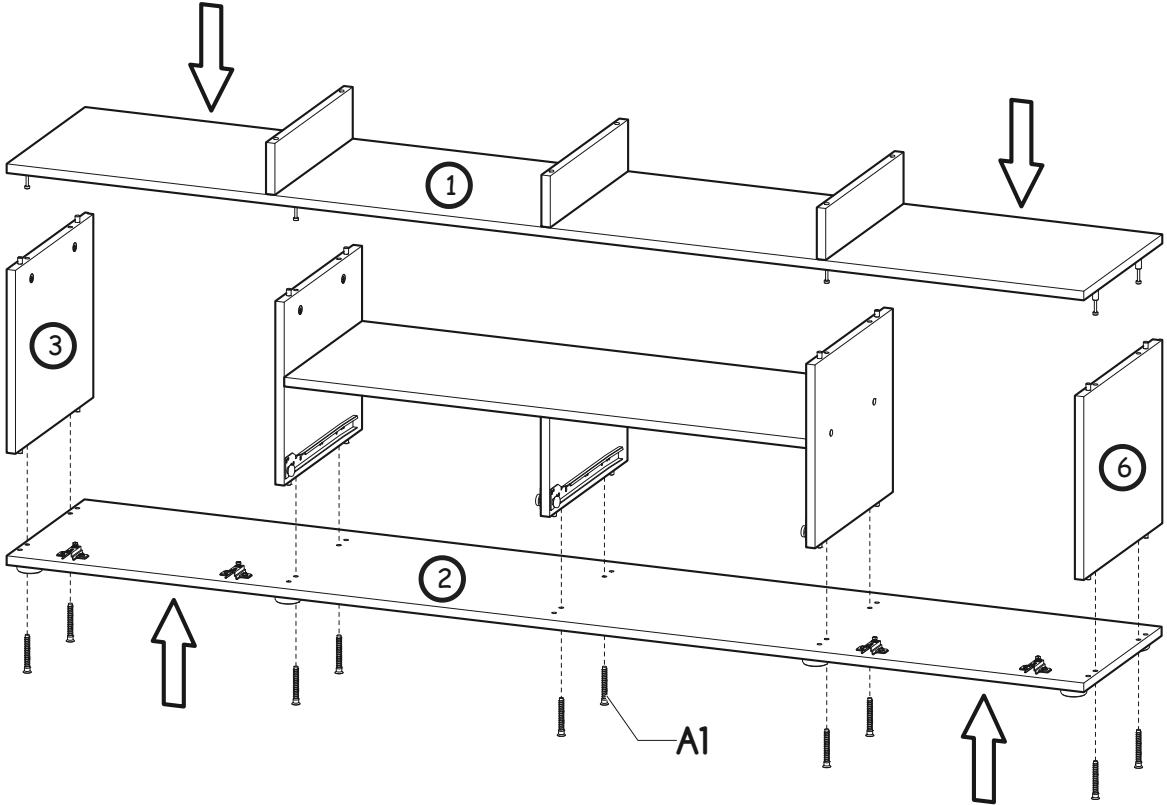

XI

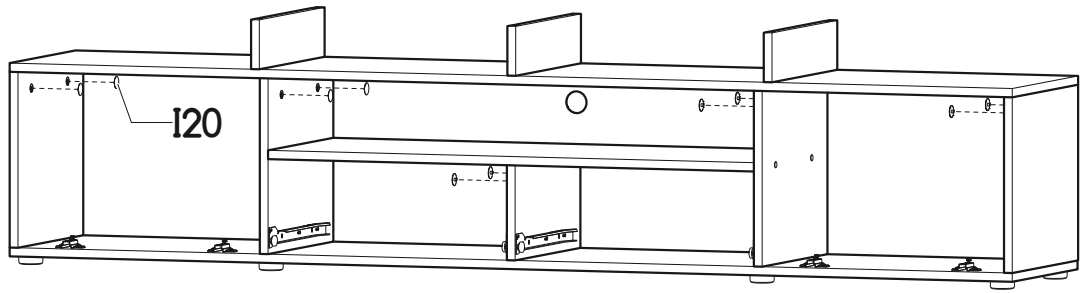
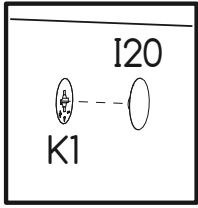

XII

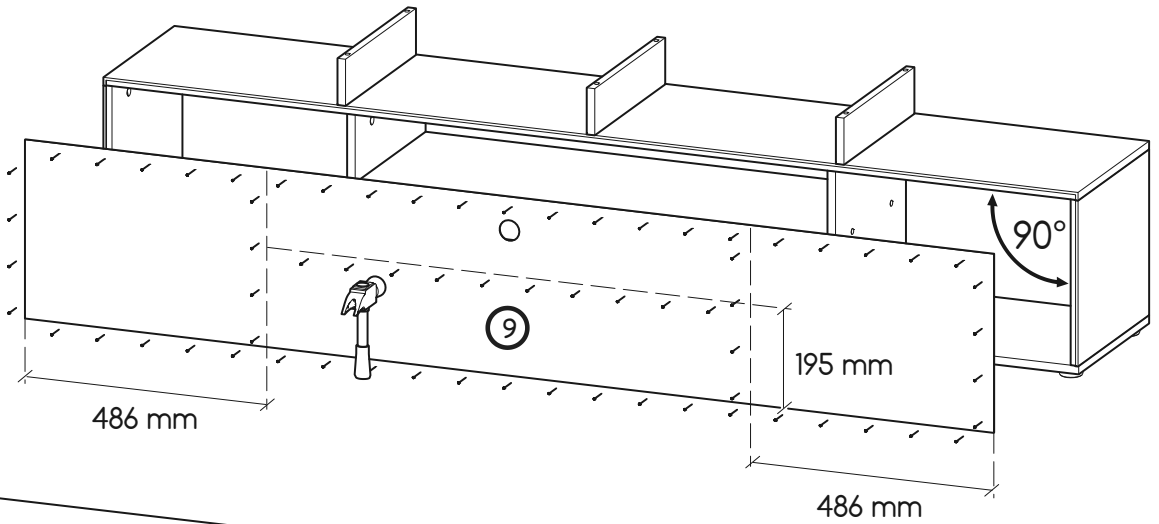

XIII

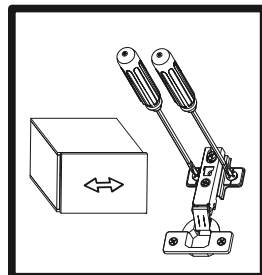
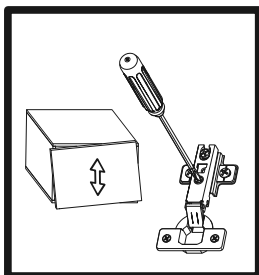
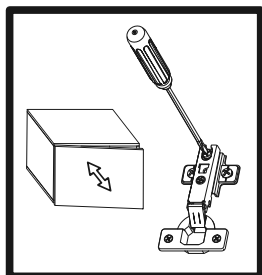
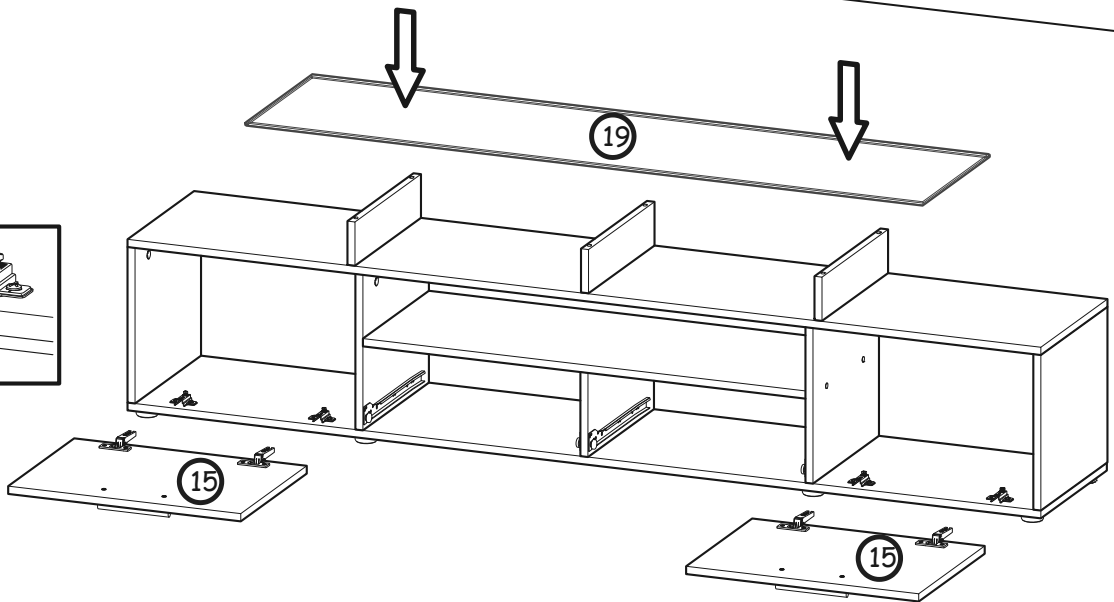
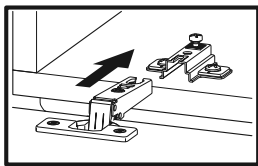

XIV

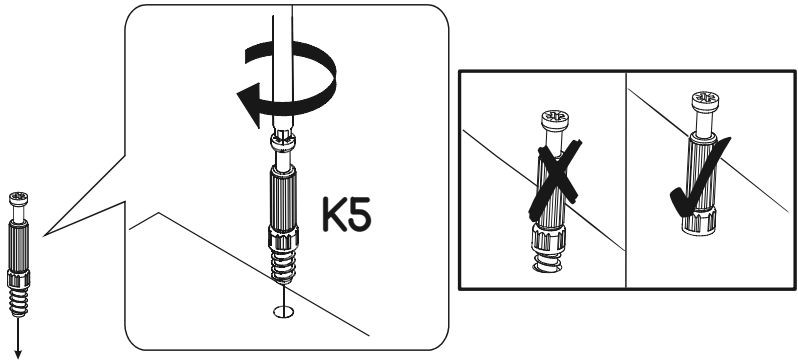
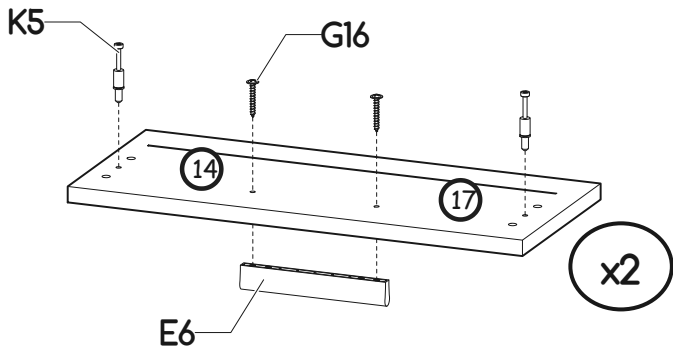
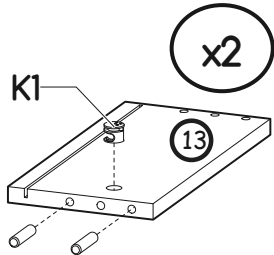
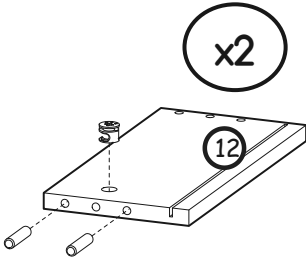
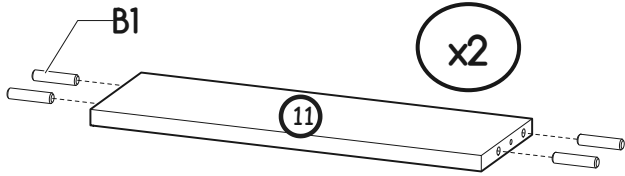
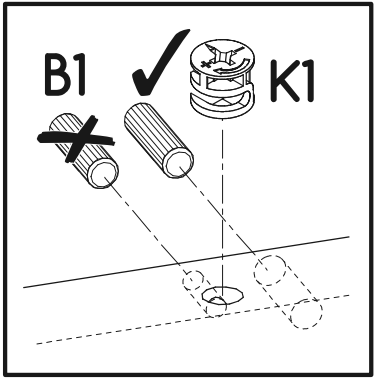
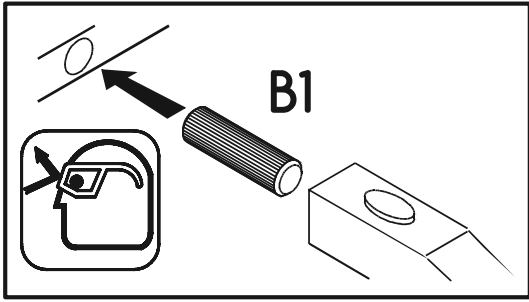

XV

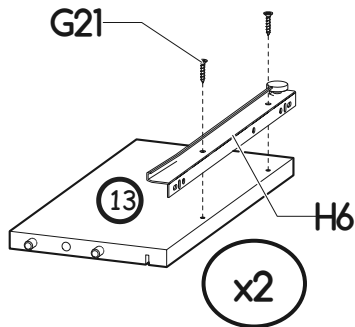
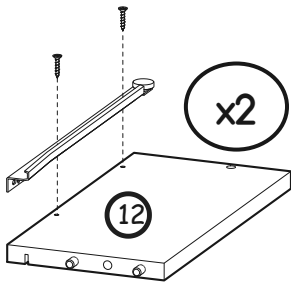

XVI

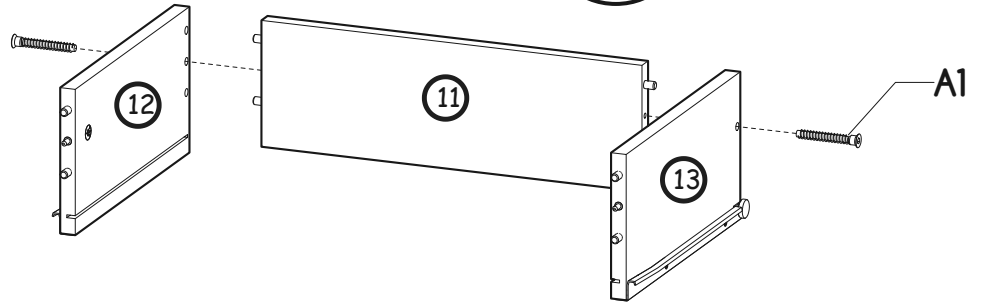
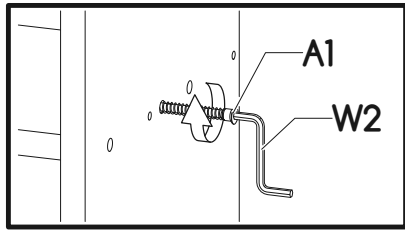

XVII

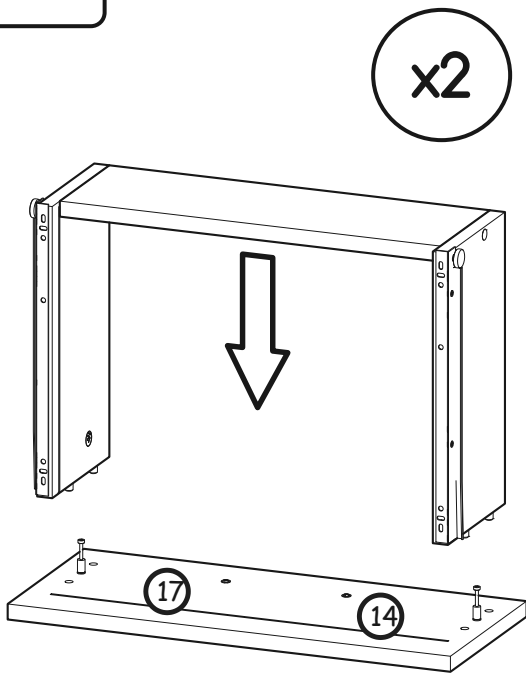

XVIII

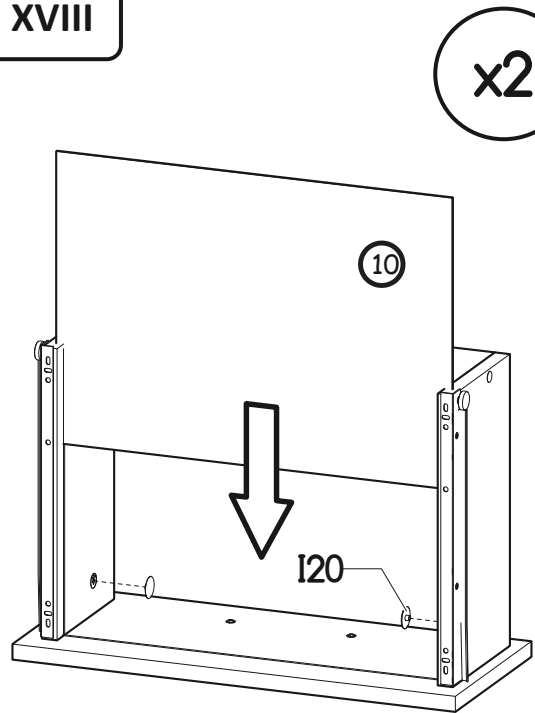

XIX

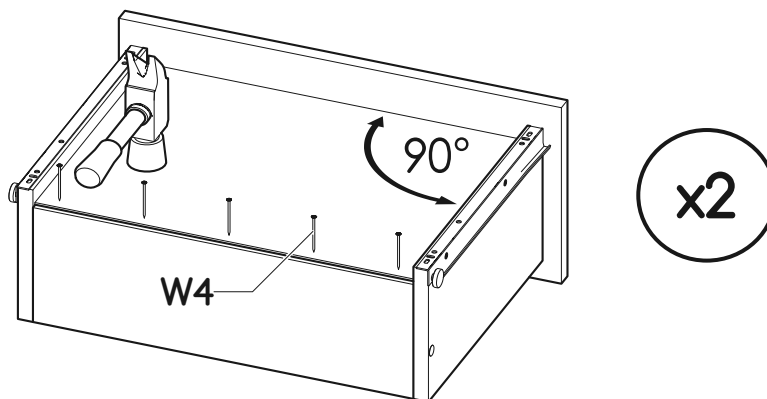

XX

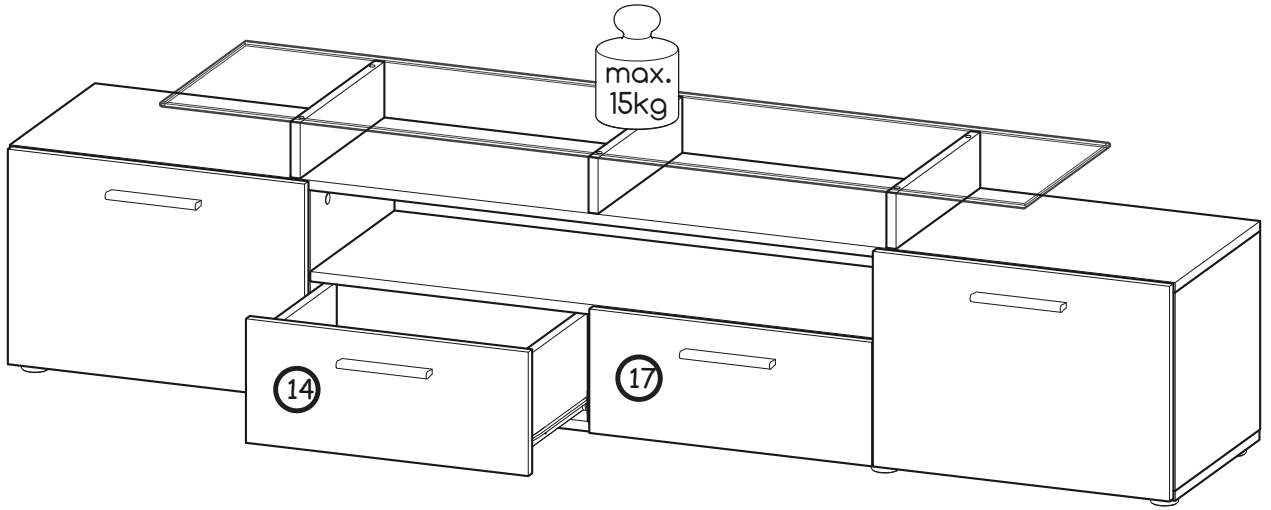

LED

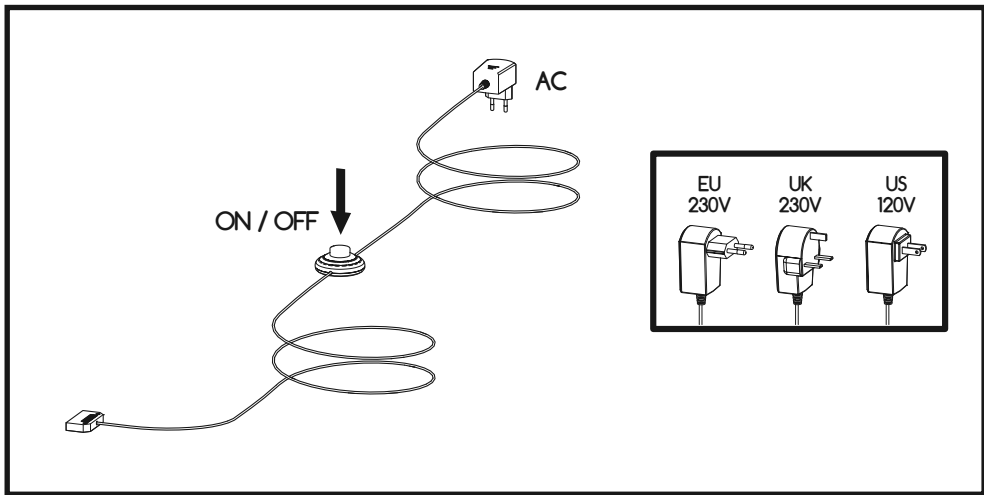
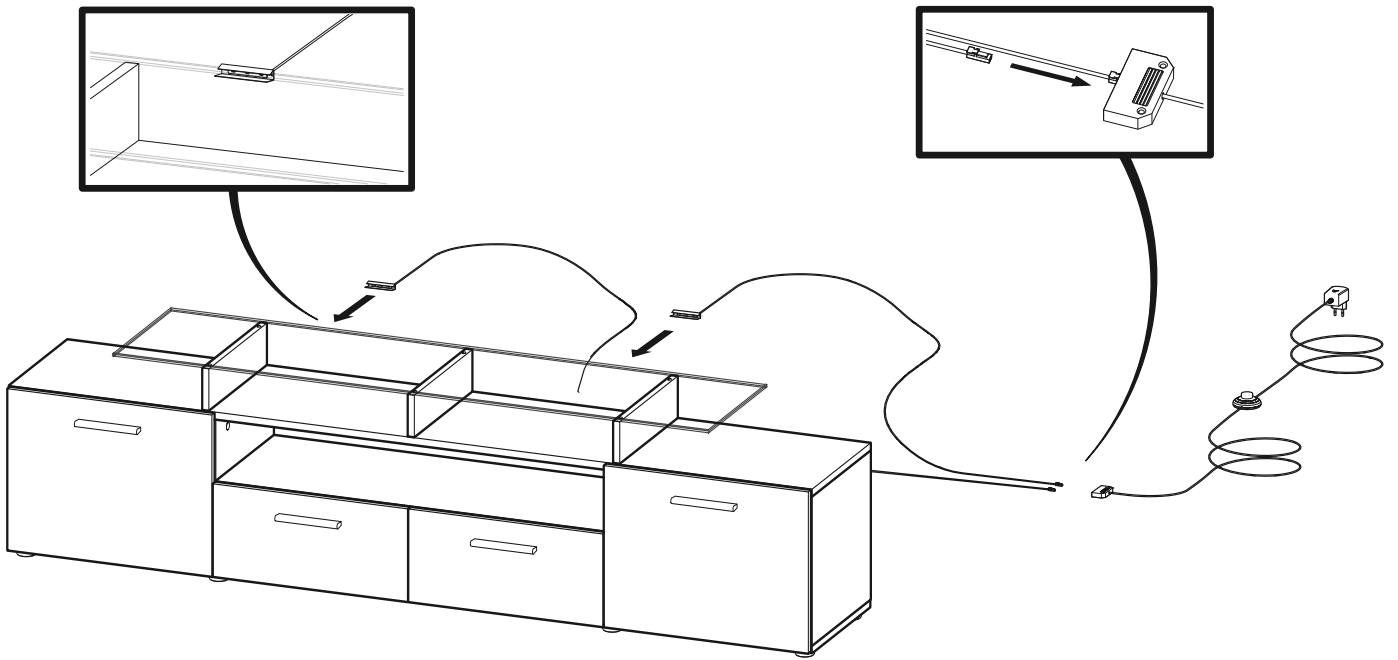

LED Light Kit Instruction Manual

What's Included in your LED Light Kit

- **LED Glass Clips and/or LED Pucks** – LED glass clips are placed directly onto glass, and emit light throughout the glass. LED pucks are attached to the surface without the need for any tools, and provide even light distribution.
- **RGB Receiver** – Transmits signal to the remote, allowing you to control your light settings. Your LED lights are 16 colored, and have different light settings.
- **Remote Control** – Allows you to easily turn your lights on/off and adjust the color as desired.
- **Splitter** – Used to connect your lights to your power supply.
- **USA Power Supply** – Used to power your LED light kit.

How to Install your Lights

1. Before installing, lay out all the products inside of the LED light kit package.
 - a. Connect each LED light to the splitter.
 - b. Connect the splitter to the RGB receiver.
 - c. Connect the RGB receiver to the power supply.
 - d. Plug the power supply into an outlet and press the ON button using the remote.
 - e. Check that everything is in working order, and then unplug your power supply & proceed with install.
2. If you have LED glass clips, you can clip them directly onto the back of the glass shelf. Never place LED lights where they are directly visible (on the front of the shelves), as they will be too bright.
3. If you have LED pucks, make sure the area where you want to attach your LED pucks is clean of dirt and debris, then attach the lights to the top of the shelves.
4. Finally, re-connect your power supply to the electrical outlet, and use your remote to change the lights to your desired color.
5. Enjoy your new TV stand lighting!

Troubleshooting

- **LED Lights Not Turning On**
 - Check your connections to make sure everything is plugged in.
 - The issue might be with the remote (refer to “Remote Not Working” section).
- **Remote Not Working**
 - Try moving closer to the receiver in case your remote is not in range.
 - Check to see if anything is blocking the signal between the remote and the receiver.
 - Make sure the receiver is exposed when installing.
- **Request a Free Replacement LED Light Kit**
 - If you are still experiencing issues after troubleshooting, you can request a replacement LED light kit shipped to you free of charge. To request a free replacement kit, please do one of the following:
 - Fill out the Parts Request form at www.mebleus.com/parts, or email help@meblefurniture.com.

**Claim your extended 90 day product warranty
by registering your product at
www.meblefurniture.com/register**

**ATTENTION: DO NOT RETURN THIS PRODUCT!!!
PLEASE READ THE FOLLOWING!!!**

FOR REPLACEMENT/MISSING PARTS:

www.meblefurniture.com/parts

**FOR INSTRUCTION/ASSEMBLY MANUALS
AND VIDEOS:**

www.meblefurniture.com/assembly

ALL OTHER INQUIRIES:

help@meblefurniture.com

**IF YOU ARE MISSING PARTS OR YOUR
PRODUCT ARRIVED DAMAGED:**

Please fill out a parts request form at
www.meblefurniture.com/parts

Replacement parts are shipped out in one business day. You will receive a tracking number via email once your parts request has been processed.

**IF YOU ARE MISSING AN INSTRUCTION
MANUAL OR NEED ASSEMBLY HELP:**

Please visit www.meblefurniture.com/assembly to access our library of product assembly videos or to download product instruction manuals.

**NOTICE REGARDING HIGH GLOSS
PROTECTIVE FOIL AND PRODUCT CARE:**

After removing the protective foil from the gloss fronts, the acrylic surface of the boards is still soft and easy to scratch. With air contact, the hygroscopic acrylic layer hardens, and the board becomes more resistant to scratches. It takes approximately 48 hours for the acrylic layer of the board to fully harden.

**DO NOT CLEAN, WIPE, OR POLISH THE
ACRYLIC FRONTS FOR 48 HOURS AFTER
REMOVING THE PROTECTIVE FOIL!!!**

