

SPECIFICATION SHEET

COLLECTION:

PRODUCT CODE: WG-RRK/DIV/SQ-148-CP



DESCRIPTION:

rigid riser kit
with diverter
with integral outlet
for use with concealed valves
1/2" threaded inlet
minimum operating pressure 1.0 bar MP

FINISH:

Chrome

FLOW REGULATOR:

FR-SHOWER/9-C/P

MINIMUM OPERATING PRESSURE:

1.0 bar MP



tel: 01934 744466
email: sales@vado.com
www.vado.com

where inspiration flows
taps | showering | accessories



TECHNICAL DRAWING

COLLECTION:

PRODUCT CODE: WG-RRK/DIV/SQ-148-CP

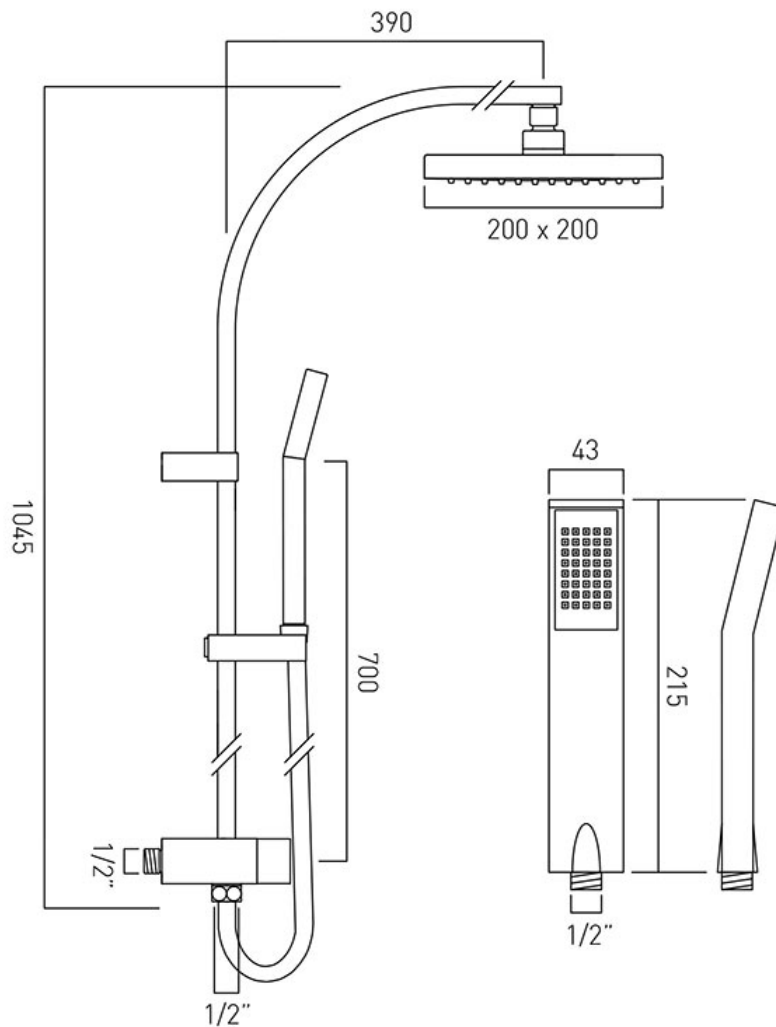

tel: 01934 744466
email: sales@vado.com
www.vado.com

where inspiration flows
taps | showering | accessories

