SPECIFICATION SHEET

COLLECTION: AXBRIDGE

PRODUCT CODE: BC-AXB-123/RRK-CP



DESCRIPTION:

Axbridge
exposed thermostatic shower valve with bath filler
wall mounted
with shower kit
with water flow straightener
intergrated diverter
with 200mm shower head
thermostatic cartridge V-702-34S
cold ceramic cartridge FL-511-RTC
hot ceramic cartridge FL-511-LTC
minimum operating pressure 1.0 bar MP

FINISH:

Chrome

MINIMUM OPERATING PRESSURE:

1.0 bar MP



Timeless Design. Pioneering Performance.

BOOTH & Co.
ENGLAND

Your journey to distinction awaits.

01934 744466 | sales@vado.com | www.vado.com/booth-and-co

TECHNICAL DRAWING

COLLECTION: AXBRIDGE

PRODUCT CODE: BC-AXB-123/RRK-CP

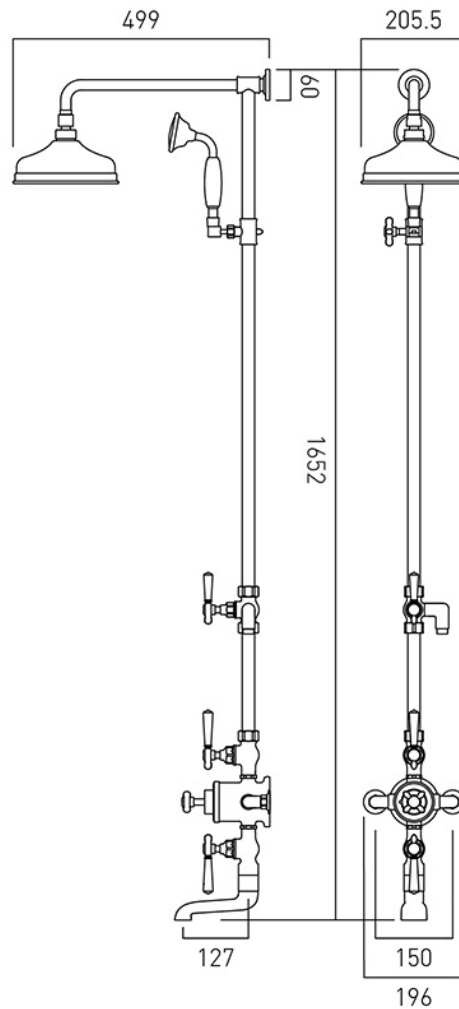

Timeless Design. Pioneering Performance.

BOOTH & Co.
ENGLAND

Your journey to distinction awaits.

01934 744466 | sales@vado.com | www.vado.com/booth-and-co