

Sales Code: OLF115

Description: 800 2-Door Mirror Unit

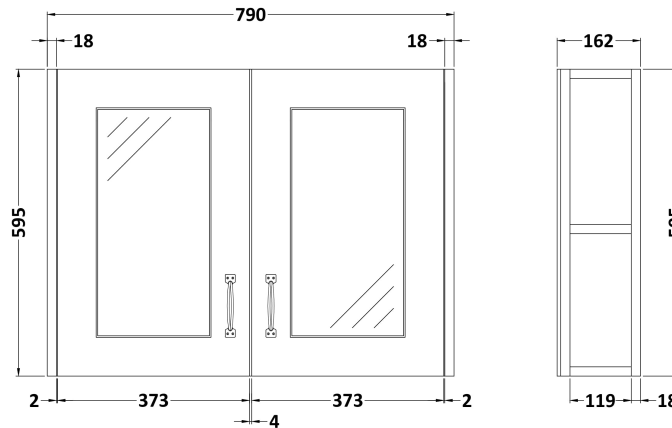

### Product Dimensions

Height (mm):	595
Width (mm):	790
Depth (mm):	162
Nett Weight (kg):	18.02

### Packaging Dimensions

Height (mm):	640
Width (mm):	810
Depth (mm):	180
Gross Weight (kg):	19.09

### Packaging Data

Box Colour:	Brown Cardboard Box
Box Qty:	1
Label Size:	100 x 50
Label Colour:	White Label
Label Qty:	2

### Outer Box Dimensions (If Applicable)

Height (mm):	
Width (mm):	
Depth (mm):	
Gross Weight (kg):	
Barcode:	5055275812891

### Product Details

Country of Origin:	United Kingdom
Fitting Instruction:	Yes
Certification:	FSC: Yes CE: Yes
Colour:	White Ash
Construction Method:	Cam & Wood Dowel
Construction Type:	Rigid
Cabinet Finish:	MFC Textured Woodgrain
Fascia Finish:	Mdf Vinyl Textured Woodgrain
Cabinet Thickness (mm):	18
Fascia Thickness (mm):	18
Drawer Included:	No
Drawer Type:	Not Applicable
No of Shelves:	1
Hinge Type:	110 Degree Inset Clip-On S/C
Hinge Included:	Yes
Adjustable Legs:	No
Fixings Included:	No
Handle Style:	Traditional
Handle Included:	Yes
Waste Shroud:	No
Handle Type:	Strap