

Sales Code: HEAD16

Description: 12" Apron Fixed Head 300mm Diameter

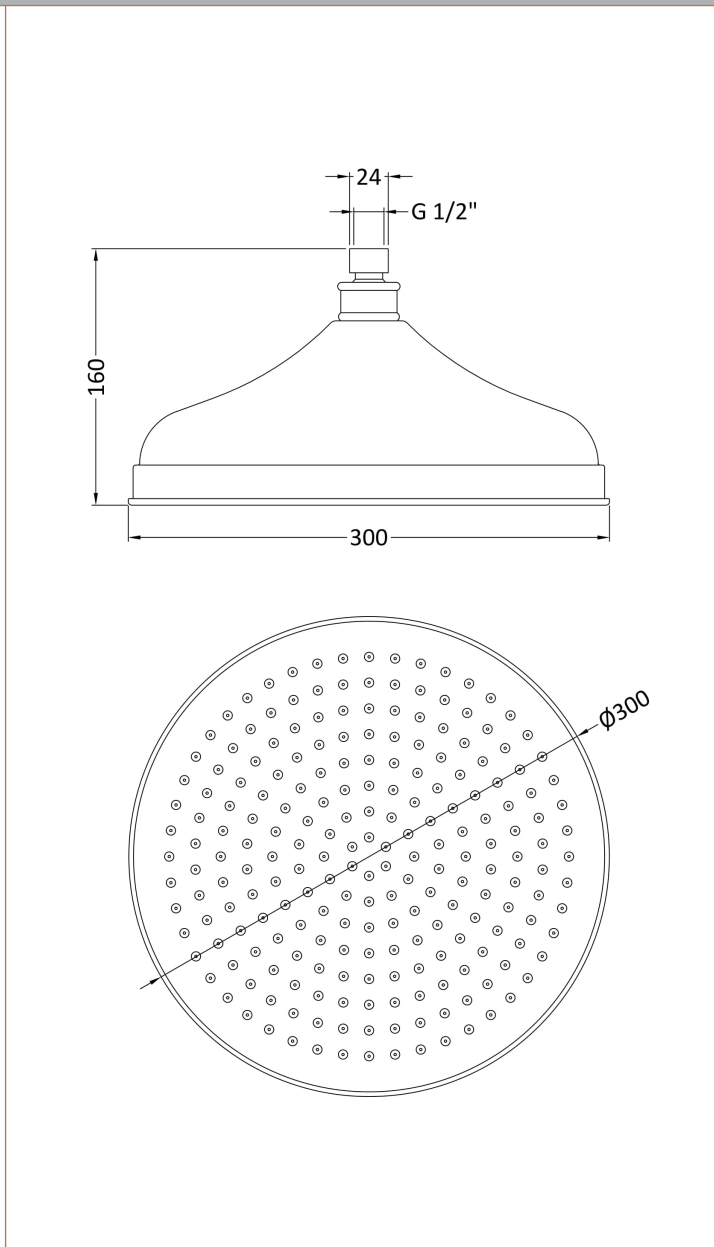

Product Dimensions

Length (mm):	
Width (mm):	300
Height (mm):	160
Depth (mm):	300
Nett Weight (kg):	1.8

Packaging Dimensions

Length (mm):	320
Width (mm):	130
Height (mm):	
Gross Weight (kg):	2.07

Packaging Data

Box Colour:	White Cardboard Box
Box Qty:	1
Label Size:	100 x 50
Label Colour:	White Label
Label Qty:	2

Outer Box Dimensions (If Applicable)

Length (mm):	
Width (mm):	660
Height (mm):	330
Depth (mm):	330
Gross Weight (kg):	10
Barcode:	5055146185819

Product Details

Country of Origin:	China
Fitting Instruction:	No
Product Material:	Brass
Mount Type:	Wall, Surface
Outlet Elbow Supplied:	No
Easy Clean:	No
Head Included:	Yes
Handset Included:	No
Body Jets Included:	Not Applicable
No of Body Jets:	Not Applicable
Operating Pressure (bar):	0.5
Valve/Cartridge Type:	Not Applicable
Flow Rates (L/min):	0.1 bar: N/A 0.5 bar: N/A 1 bar: N/A 2 bar: N/A 3 bar: N/A
TMV2 Approved:	No Approval No: N/A
TMV3 Approved:	No Approval No: N/A
WRAS Approved:	No Approval No: N/A
Head Function:	Single
Handset Function:	Not Applicable
Body Jet Info:	Not Applicable
Pipe Size:	Not Applicable
Pipe Centres:	N/A
Colour/Finish:	Chrome
Hose Included:	Not Applicable
No. of Outlets:	N/A