

matki | SHOWERING

NEW RADIANCE PIVOT INLINE DOOR RECESS NRI1200

INSTALLATION

PARTS LIST

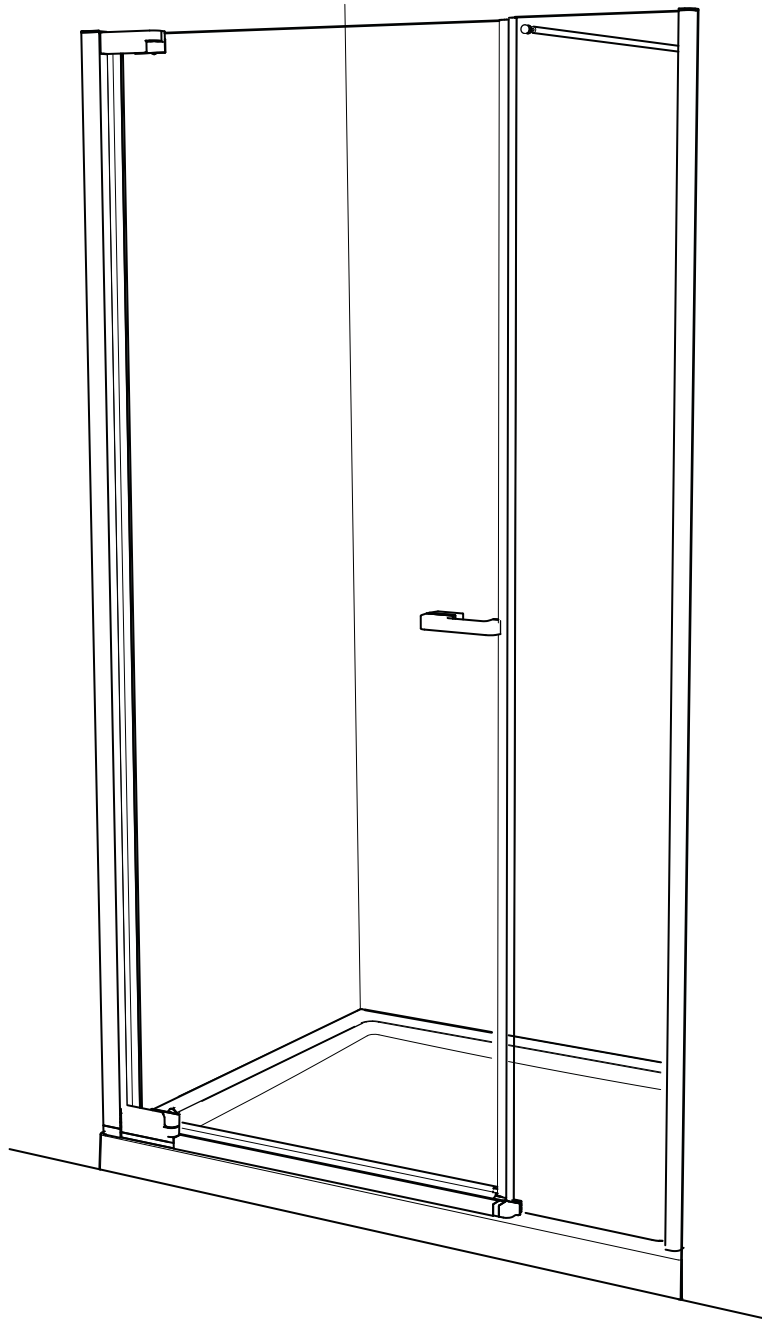

MATKI PLC, CHURCHWARD ROAD, YATE, BRISTOL, BS37 5PL
TELEPHONE:01454 328816 (AFTER SALES) FAX:01454 328821 EMAIL: techsupport@matki.co.uk

IMPORTANT

Before disposing of carton and/or commencing assembly, please check all the parts to ascertain that none are missing and they are all undamaged. No claim for missing/damaged parts will be accepted once the packing carton has been disposed of and/or assembly has commenced.

In case of query contact your Stockist with details of model number and details of serial number.

PREPARATION

Please read complete installation instructions before fitting. We recommend a **drainage test** is carried out before the tray is tiled in. **Ensure top of tray is level**, tray should be let into wall with tiling lip face flush with the wall to allow tiling to overlap tiling lip. **The assembly should be installed onto waterproof wall covering and installed after the Tray and wall coverings are in place. Ensure Walls are plumb for upright.**

Carefully remove assembly from carton, do not place glass on hard floor or expose edges to impact.

Ensure top of tray is level. Seal between tray and tiles. Remove any excess sealant from the area/joint between the tray and tiles where the Wall Mount will be fitted this will ensure the Wall Mount fits correctly to the wall and tray.

CAUTION: TEMPERED GLASS CANNOT BE CUT, POLISHED METAL AND CHROME CAN BE SCRATCHED.

TOOLS REQUIRED

Masonry Drill bit 6mm, Tape Measure, Screw Drivers, Safety Glasses, Electric Drill, Level, Pencil, Adjustable Spanners.

TYPICAL INSTALLATION OF SHOWER TRAY

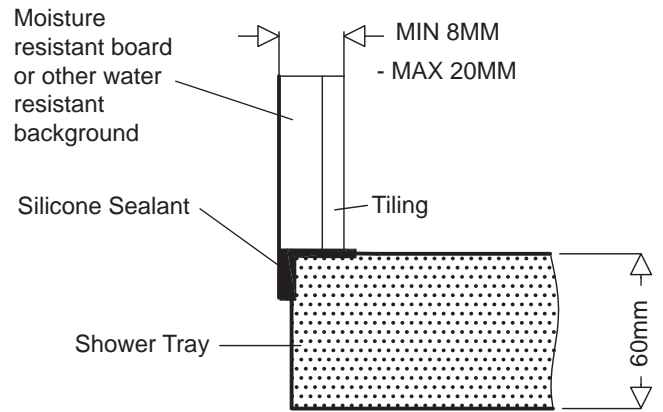

ENSURE TOP OF SHOWER TRAY IS LEVEL

DIMENSIONS

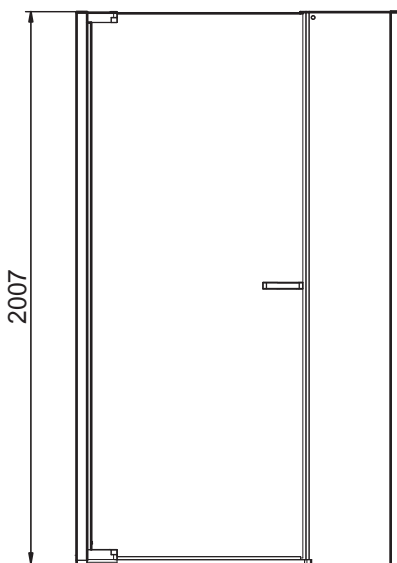

MODEL	A	B	RECOMMENDED TRAY MODEL
NRI1200	1163-1200	570	SN1276/SN1280/ SN1290/SAS1290

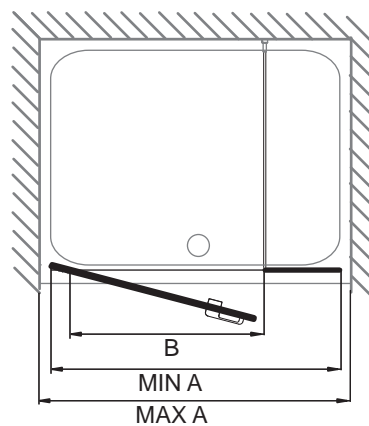

LH ENTRANCE

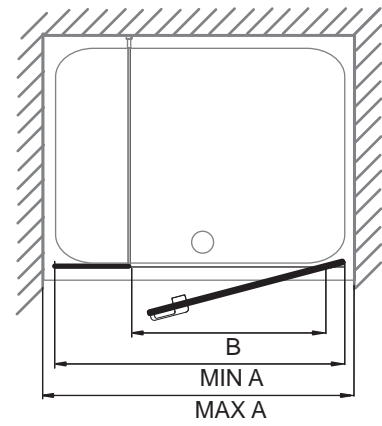

RH ENTRANCE

STAGE 1

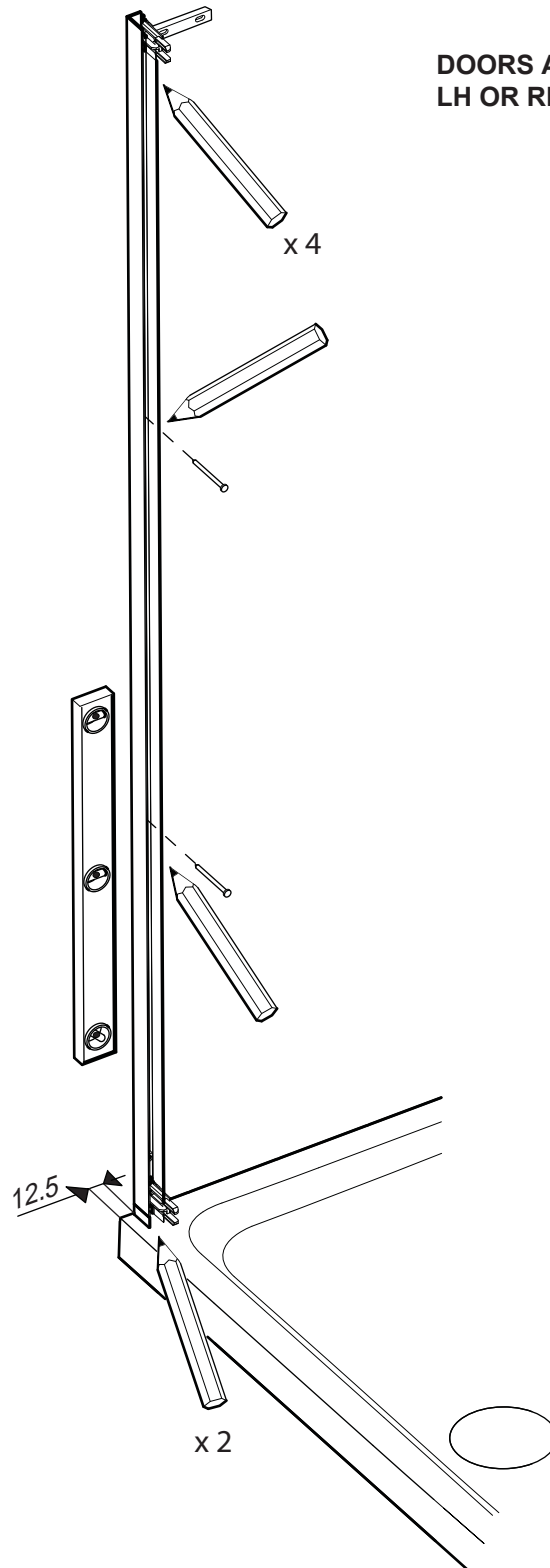
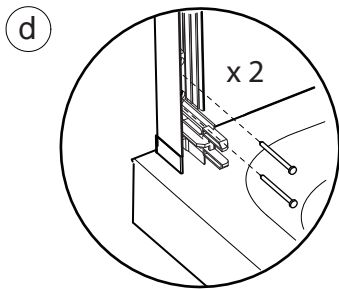
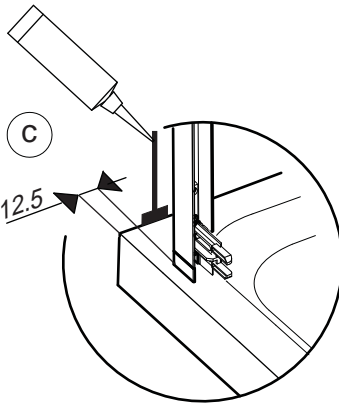
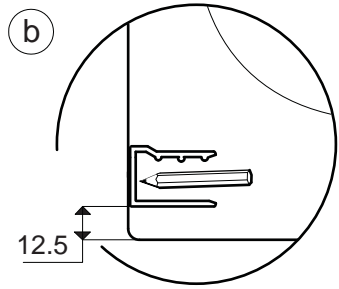
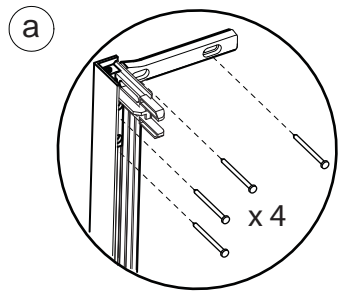

DOORS ARE BUILT AS SPECIFIED AS EITHER LH OR RH.

This Stage is describing the fitting of the Pivot Wall mount.

Place Wall mount assembly onto the tray. Position the Wall mount on to the Wall 12.5mm away from the front edge of the tray (1b/c).

Plumb the Wall mount for upright and mark the 8 x fixing holes in the centre of the slots in the back face of the Wall mount and Wall bracket assemblies (1b,d,a).

Drill the fixing holes in the wall and insert the Wall plugs. Clean the area. Apply Silicon sealant to the area behind the Wall mount between the tray and the tiles and 100mm up the wall (1c). Fit the Wall mount with the 8 x No8 x 32mm screws (Kit of parts) (1d,a).

STAGE 2

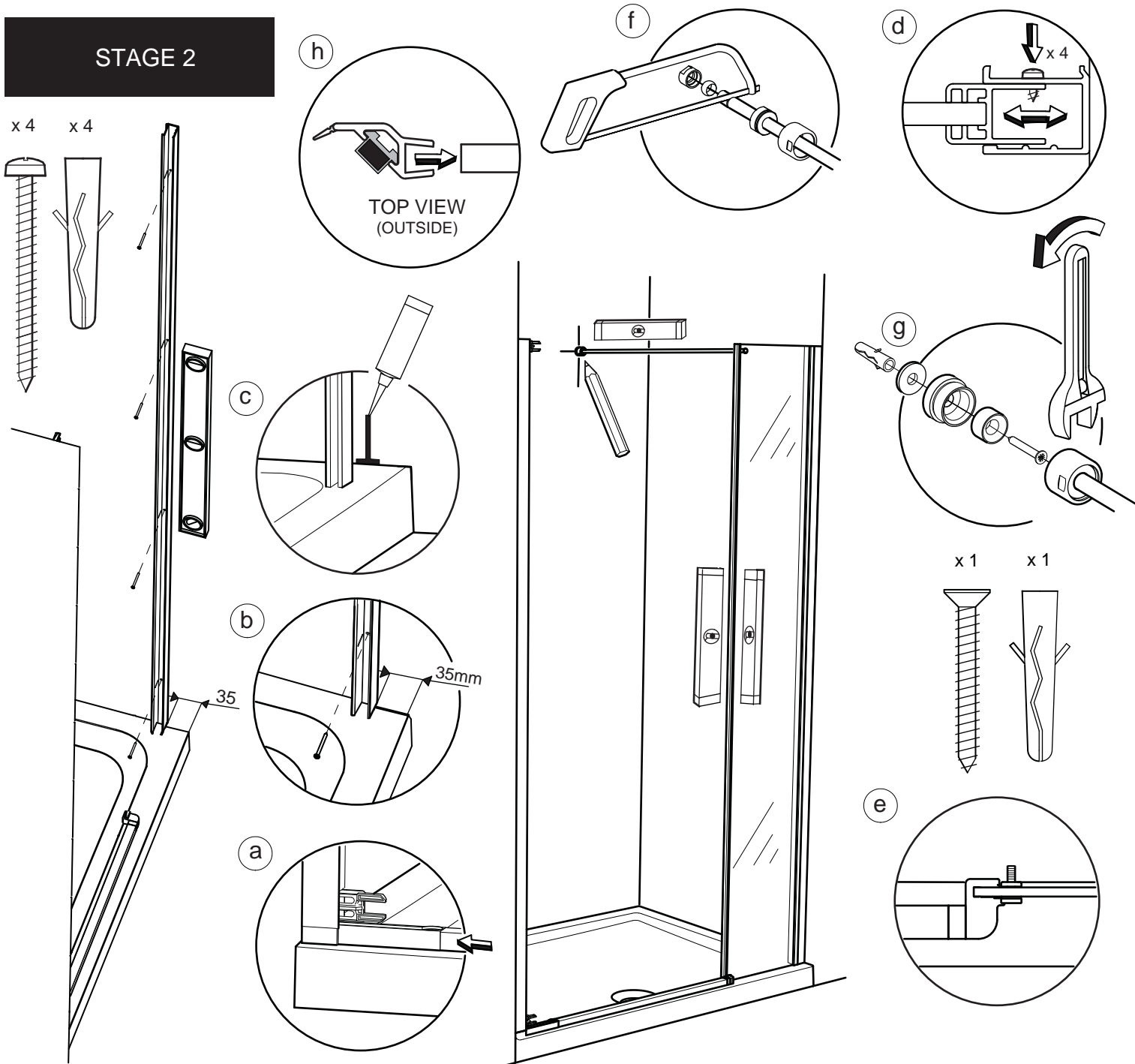

This Stage is describing the fitting of the Tray threshold and , Inline Wall mount and Brace.

Slide the Threshold assembly into the Lower pivot bracket (2a) Ensure the Threshold is parallel to the outer edge of the tray.

Place the Inline wall mount onto the wall and onto the Tray. As a guide the outer face of the Inline wall mount should be 35mm away from the outside edge of the tray (2b). Plumb the Inline wall mount for upright, mark the centre of the adjustment slots in the back face. Drill and fix in position using Wall plugs and the 4 x No.8 x 32mm Pan Head screws (Kit of parts). Apply Silicon sealant to the area behind the Wall mount between the tray and the tiles and 100mm up the wall (2c). Carefully lower the Inline Panel into the Inline Wall Mount and push fit the opposite lower corner of the Inline Panel into the Threshold assembly (2e). Check the Inline panel and Threshold are parallel to the front edge of the tray and secure using the 4 x No.6 x 9.5mm Pan Head Screws (2d).

To fix the Brace to the Inline Panel accurately measure and mark the length to be removed (**only remove material from the unthreaded end of the Brace**) To cut the Brace to the desired length slide the Brace Nut away at the Wall Plate end, set aside the Wall Plate assembly and unscrew the Compression fitting (2f). To accurately measure the length of the Brace bar needed check the Inline panel for upright. After shortening the Brace reassemble the Compression fitting, and screw the Brace nut onto the Wall Plate assembly. Screw the threaded end of the Brace onto the fixing on the Inline glass panel. Using a level, plumb and mark the centre of the Wall plate. Drill the fixing hole in the wall and insert the Wall plug. Fix the Wall plate to the wall using the No 8 x 32mm Csk screw ensuring the Rubber washer (Kit of Parts) is fitted behind the Wall plate and the Wall plate gasket is fitted inside the Wall plate (2g). Refit the threaded end of the Brace onto the fixing on the Inline glass panel and screw the Brace nut to the Wall plate (2g) .

Fit the Closure wall mount seal onto the edge of the glass panel as shown (h). The magnet can be removed and re-inserted into the seal the opposite way up to reverse the polarity.

STAGE 3

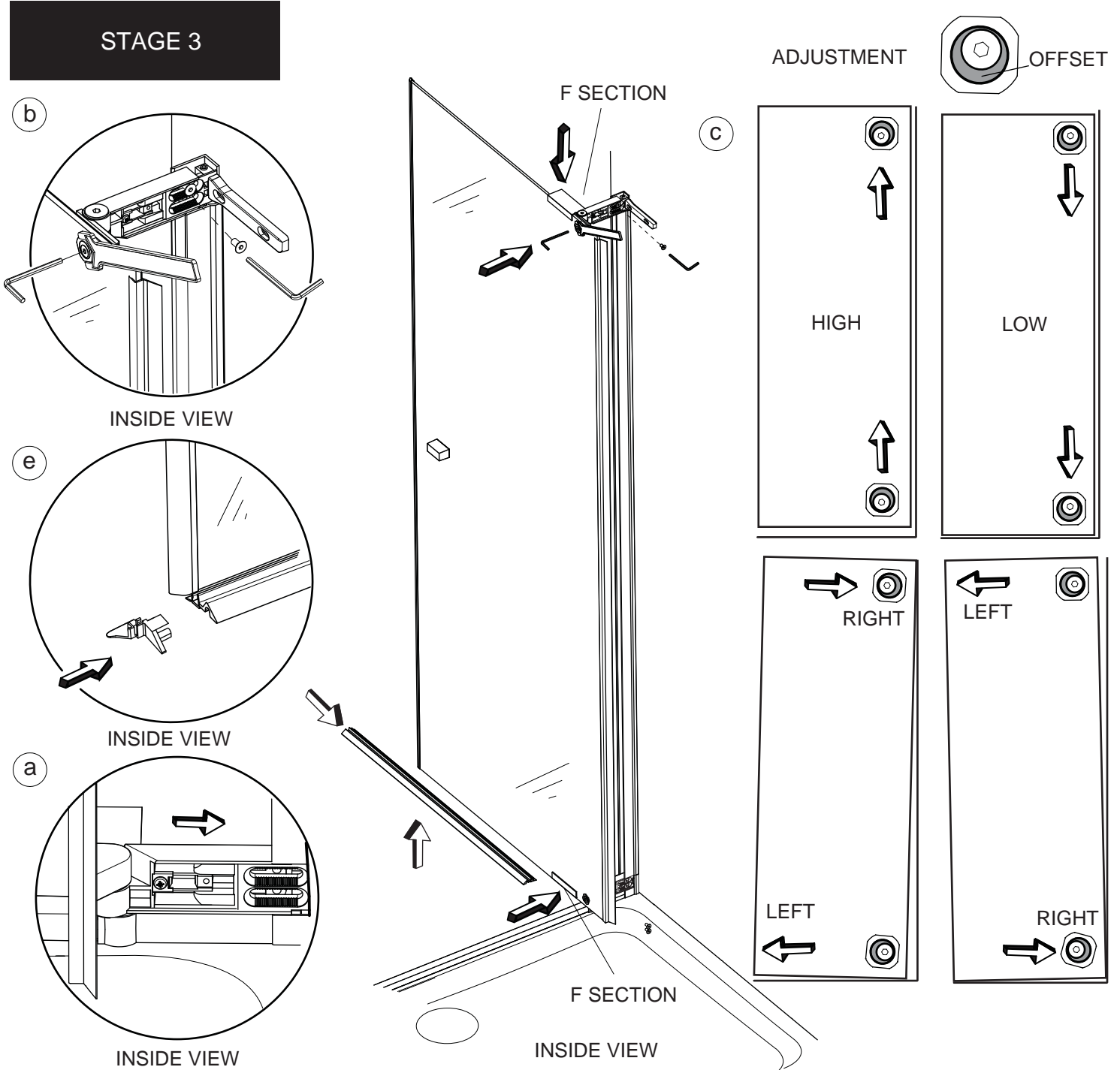

This Stage is describing the fitting of the Door.

Rotate both Hinges 90 degrees to the Door glass and temporarily fix in place using the F Sections provided in the kit of parts. Secure F sections in place using masking tape. Carefully feed the Door hinges onto the Wall brackets, taking care not to scratch the Threshold (3a). Fix the Door hinges on to the brackets using the 4 x M6 x 12 Countersunk socket screws (3b). Do not overtighten these screws at this stage. Check that the front face of the lower Door hinge aligns with the front face of the Threshold. Adjust as needed. Remove the F sections from the Door hinges and allow the Door to close.

Door adjustment - The door can be adjusted to the Closure extrusion by adjusting the Hinges in the Pivot brackets. Smaller adjustments to the Door closure position can be made using the 2 x Hinge Cams on the inside of the Door hinges. To make adjustments to the Door closure carefully loosen the fixing screws in the centre of the Hinge Cams (with Allen key provided) so that the Cam nut can be rotated with an adjustable spanner. Do not fully loosen (3b). The door is factory set in the high position and at the mid point of left and right adjustment. To **lower** the door rotate both the top & bottom Cam Nut positions downwards so the Cam offset is downwards. (3c) To adjust the **top** of the door to the **left or right** rotate the Cam Nut so that the cam offset is to the left or right. (3c) To adjust the **bottom** of the door to the **left or right** rotate the Cam Nut so that the Cam offset is to the left or right. (3c) Tighten the Cam fixing screw after adjustment.

Push fit the Door seal to the underside of the Door, fitting the cut out side of the Seal to the Hinge side. Push fit the Door seal end cap (3e).

STAGE 4

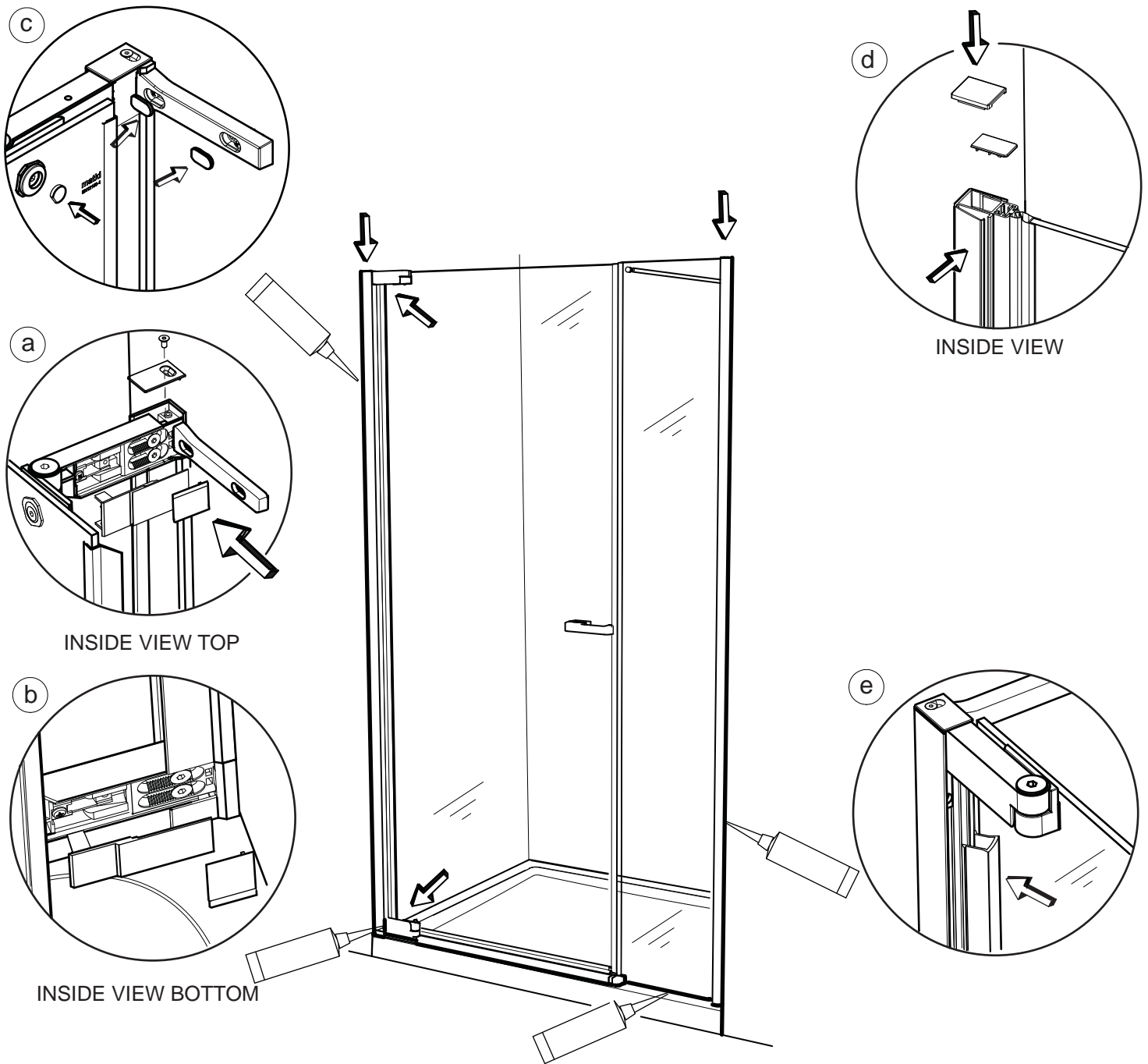

This Stage is describing the fitting of the Caps, Covers and Silencing.

Adjust the Magnetic seals along the length of the Door to provide an effective closure and to prevent the Door opening inwards. This can be done by using the adjustment available in the Wall Mounts, Cams, Hinges and Magnetic seals.

Fully tighten the 4 x M6 Screws when Door alignment has been achieved. Fit the Door hinge covers (4a,b) Fit the Pivot wall mount top cap using the M4 x 8 Countersunk socket screw (Kit of parts) (4a).

Fit the Hinge bracket screw cover caps and the Hinge cam caps (4c).

Fit the Inline wall mount cover (4d). Push fit the Inline wall mount top caps (4d). Fit the Screw cover into the Hinge panel wall mount, fitting the inner leg first (4e).

Apply a thin bead of Silicon along all outside joints. Seal the joint between the Pivot wall mount and lower Hinge. Between the Wall and Wall mounts and between the tray and Threshold/ glass. Masking tape can be used to achieve a tidy edge to the sealant. Remove masking tape immediately and allow the Silicon to cure for 24 hours before using the shower.

MAINTENANCE

Matki Glass Guard Easy Clean Surface Protection (optional) and General Cleaning Guide

Cleaning Instructions

Matki Glass Guard allows water to form minute beads which easily trickle off the surface of the glass. This makes the glass easier to clean - the glass does not need to be cleaned as frequently, but it does require occasional maintenance. As less cleaning is required the use of detergents can be minimised thus helping to protect the environment. The lifespan of the Matki Glass Guard is dependant on the frequency of use of the shower and the degree of water hardness.

The combination of alkaline materials and humidity affects glass in an extremely aggressive way. Do not use bleach, alkaline, acid-based or aggressive and abrasive glass cleaners, detergents or household cleaning products on the glass or frames.

We recommend that glass is washed down with clean water and a soft clean cloth or sponge and dried off with a microfibre cloth.

The special coating is only present on the inside of the glass.

Matki Glass Guard is guaranteed for 2 years provided that the guidelines and cleaning instructions are followed.

Aluminium and Chrome parts should be cleaned with a mild non scratch household cleaner and a soft cloth or sponge.

Do not use acidic-based descaler products or products which are unsuitable for cleaning enamelled surfaces, including abrasive cleaners or cleaners containing bleach or solvents, as the products will effect the anodised framework. Under no circumstances use cleaners with a pH level exceeding 8.

Matki does not recommend the use of 'Leave-on' shower cleaners on Matki Glass Guard Products.

Water Softeners and Glass Guard - Certain types of water softeners increase the alkalinity of the water due to a carry-over of Chloride during re-generation which can cause aggressive water spots on both untreated and Glass Guarded glass. If using a water softener we recommend a two-cylinder machine with automatic re-generation instead of a timer.

If a single-cylinder water softener with timer is already installed it is recommended that after each shower excess water is removed from the glass with a squeegee or with a micro-fibre cloth.



Wash down with clean warm water and a soft clean cloth or sponge.



Do not use bleach, alkaline or acid-based, aggressive or abrasive cleaning products.

Flash Bathroom Spray or Cif Bathroom Spray can be used on Matki Products.

Various specialist cleaning and glass dressing products are available from Ritec International Ltd Tel. 020 8344 8210 or www.ritec.co.uk.

Matki Plc is not connected with Ritec International Ltd in any way and the contact details are supplied for information only. Read manufacturers label before using any cleaning materials.

IMPORTANT

Matki Glass Guard is guaranteed for 2 years. It is essential that the cleaning instructions are followed in order to maintain the hydrophobic properties of the glass coating. In the event of the failure to comply in any way with these instructions, any warranty or guarantee will be null and void.

MATKI PLC, CHURCHWARD ROAD, YATE, BRISTOL, BS37 5PL
TELEPHONE:01454 328816 (AFTER SALES) FAX:01454 328821 EMAIL: techsupport@matki.co.uk



matki | SHOWERING

13

Matki PLC, Churchward Road, Yate,
Bristol BS37 5PL

EN 14428:2008+A1

PARTS LIST

We recommend that these instructions are handed to the user with a note of a date of purchase and model details.

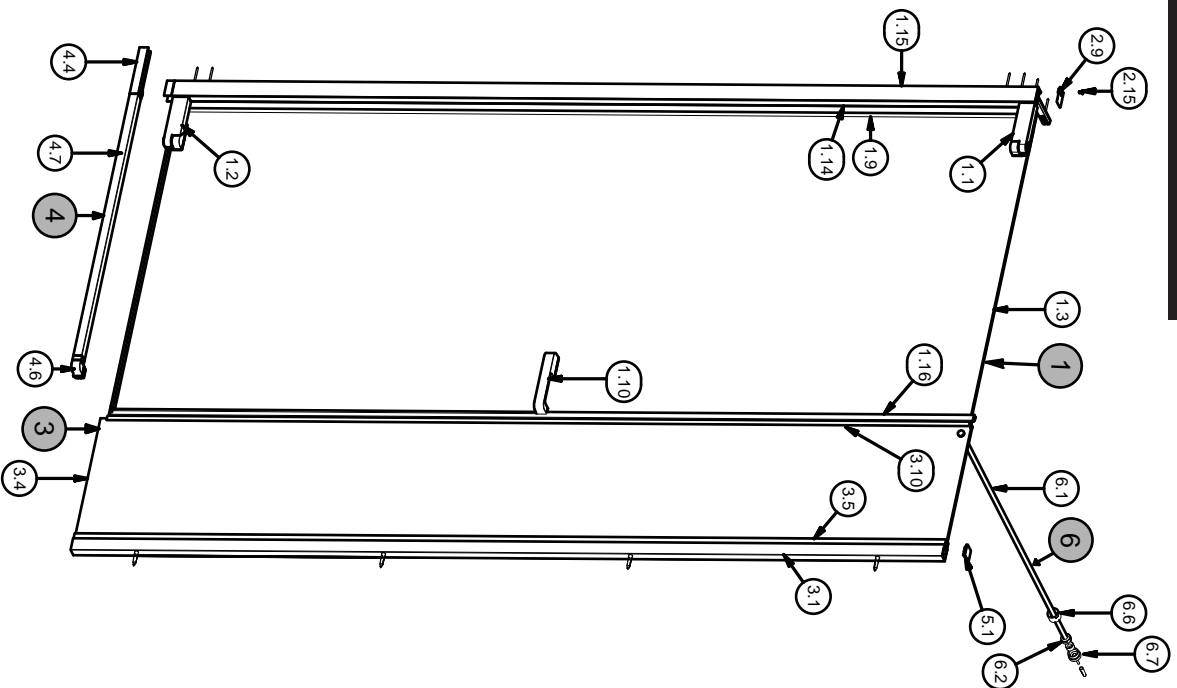

6 RADIANCE INLINE BRACE			
6.1	WALL BRACE BAR	5429 A SILVER	1
6.2	BRACE COMPRESSION A	5424 A SILVER	1
6.3	BRACE COMPRESSION B	5425 A SILVER	1
6.4	BRACE COMPRESSION C	5430 AF	1
6.5	WALL PLATE GASKET	7512 BLACK	1
6.6	BRACE NUT	6202 A SILVER	1
6.7	WALL PLATE	6203 A SILVER	1

ITEM	DESCRIPTION	PART No.	QTY	LENGTH
1 RADIANCE PIVOT DOOR				
1.1	RADIANCE PIVOT TOP PIVOT BRACKET SUB-ASSEMBLY		1	
1.2	RADIANCE PIVOT LOWER PIVOT BRACKET SUB-ASSEMBLY		1	
1.3	DOOR GLASS	3942 M CLEAR/PLAIN	1	
1.4	CAM GLASS WASHER	5371 BLACK	2	
1.5	INSIDE HANDLE	5375 A SILVER	1	
1.6	THRESHOLD SEAL	2292 CLEAR	1	
1.7	HANDLE PLATE	5383 BLACK	1	
1.8	HANDLE PLATE	5384 BLACK	2	
1.9	DOOR SEAL	2293 CLEAR	1	
1.10	HANDLE OUTER	5368 A SILVER	1	
1.11	SKT SET SCREW	1274 A SILVER	2	M4 x 6
1.12	HANDLE CONNECTOR	5401 AF	2	
1.13	CAM	5370 A SILVER	2	
1.14	WALL JAMB CLIP IN FOIL	2294 A SILVER	1	
1.15	DOOR WALL JAMB HINGE SIDE	5496 A SILVER	1	
1.16	DOOR GLASS SEAL	2285 AF	1	
1.17	CSK SKT SCREW	1415 A SILVER	2	M6 x 16
1.18	HINGE TOP BRACE	5386 A SILVER	1	
1.19	HINGE FOOT LH COLUMN	5381 A SILVER	1	
1.20	HINGE FOOT RH COLUMN	5382 A SILVER	1	
2 RADIANCE PIVOT DOOR PARTS KIT				
2.1	PAN SELF TAPPING SCREW	1471 A SILVER	8	No.8 x 32
2.2	HINGE CAM CAP	5581 A SILVER	2	
2.3	BASE HINGE COVER PLATE	5385 A SILVER	1	
2.5	THRESHOLD SEAL END CAP LH	5515 AF	1	
2.6	HINGE JAMB TOP CAP	5388 A SILVER	1	
2.9	110 THRESHOLD SEAL END CAP RH	5516 AF	1	
2.10	BASE HINGE COVER PLATE	5513 A SILVER	1	
2.11	HINGE BRACKET CAP	5579 A SILVER	2	
2.12	HINGE PLATE	5366 A SILVER	2	
2.13	WALL PLUG	1818 AF	8	
2.14	CSK SKT SCREW	1499 A SILVER	1	M4 x 8
2.15			1	
3 RADIANCE INLINE PANEL				
3.1	RECESS WALL JAMB	5506 A SILVER	1	
3.2	PAN SELF TAPPING SCREW	1405 A SILVER	4	No.6 x 9.5
3.3	WALL JAMB SNAP IN COVER	2284 A SILVER	1	
3.4	INLINE PANEL	3861 M CLEAR/PLAIN	1	
3.5	INLINE JAMB ADJUSTER	5508 A SILVER	1	
3.6	PANEL CLAMP	5400 AF	1	
3.7	BRACE BAR WASHER	5377 BLACK	1	
3.8	BRACE BAR RETAINER	5601 AF	1	
3.9	PANEL CLAMP WASHER	5374 BLACK	1	
3.10	INLINE PANEL SEAL	2323 CLEAR	1	
4 RADIANCE INLINE THRESHOLD ASSEMBLY				
4.1	PANEL CLAMP	5403 AF	1	
4.2	GLASS FOOT CLAMP	5514 AF	1	
4.3	INLINE FOOT BACK	5392 A SILVER	1	
4.4	HINGE FOOT	5598 A SILVER	1	
4.5	BRACE BAR WASHER	5377 BLACK	1	
4.6	INLINE FOOT	5376 A SILVER	1	
4.7	THRESHOLD	5533 A SILVER	1	
5 RADIANCE INLINE PANEL PARTS KIT				
5.1	RECESS WALL JAMB CAP OUTER	5390 A SILVER	1	
5.2	RECESS WALL JAMB CAP (INNER)	5389 A SILVER	1	No.8 x 38
5.3	CSK SELF-TAPPING SCREW	1443 A SILVER	1	No.6 x 38
5.4	PAN SELF TAPPING SCREW	1470 A SILVER	4	
5.5	WALL PLUG	1818 AF	5	