

matki | S H O W E R I N G

MATKI ONE

MOPCREVERSE - INLINE CORNER PIVOT REVERSE

INSTALLATION

PARTS LIST



MATKI PLC, CHURCHWARD ROAD, YATE, BRISTOL, BS37 5PL
TELEPHONE:01454 328816 (AFTER SALES) FAX:01454 328821 EMAIL: techsupport@matki.co.uk

IMPORTANT

TOOLS REQUIRED

Masonry Drill bit 6mm, Tape Measure, Screw Drivers, Safety Glasses, Electric Drill, Level, Pencil, Adjustable Spanners, Non Slip Gloves

Before disposing of carton and/or commencing assembly, please check all the parts to ascertain that none are missing and they are all undamaged. No claim for missing/damaged parts will be accepted once the packing carton has been disposed of and/or assembly has commenced.

In case of query contact your Stockist with details of model number and details of serial number.

PREPARATION IMPORTANT

1. Please read complete installation instructions before fitting for Enclosure and Tray (if fitting).
2. We recommend the use of Safety glasses and Non slip gloves when handling the glass panels.
3. Ensure that the product can be **fixed** to a **solid masonry wall** or suitable **timber stud work grade C16/C24** in the area behind the Wall frames.
4. Shower trays or tiled floors **must be absolutely level** where enclosures are fitted
5. If fitting a tray we recommend a **drainage test** is carried out before the tray is tiled in position.
6. The assembly should be installed onto a waterproof wall covering and installed after the Tray and wall coverings are in place. Where Tiling lips are provided Trays should be let into the Wall with the Tiling lip flush with the wall to allow the Tiling to overlap the Tiling lip.
7. Seal between tray and tiles. Remove any excess sealant from the area/joint between the tray and the tiles where the Wall Mount is to be fitted. This will ensure the Wall mount fits correctly to the wall and tray/or tiled floor.

CAUTION: TEMPERED GLASS CANNOT BE CUT, POLISHED METAL AND CHROME CAN BE SCRATCHED. CAREFULLY REMOVE ASSEMBLY FROM CARTON, DO NOT PLACE GLASS ON HARD FLOOR OR EXPOSE EDGES TO IMPACT.

DIMENSIONS

INLINE CORNER PIVOT REVERSE 1000/1100/1200 x 760/800/900

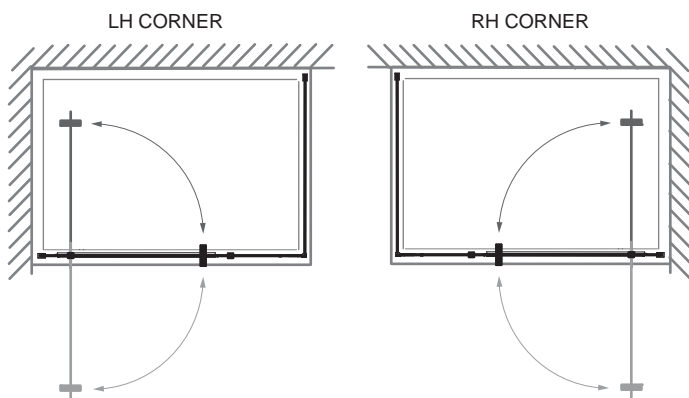

Model	A	B	C	D
MOPC1000REVERSE	973-993	80-100	560	265
MOPC1100REVERSE	1073-1093	80-100	600	325
MOPC1200REVERSE	1173-1193	80-100	700	325

Side Panel	E
MOPCSP760	732-752
MOPCSP800	772-792
MOPCSP900	872-892

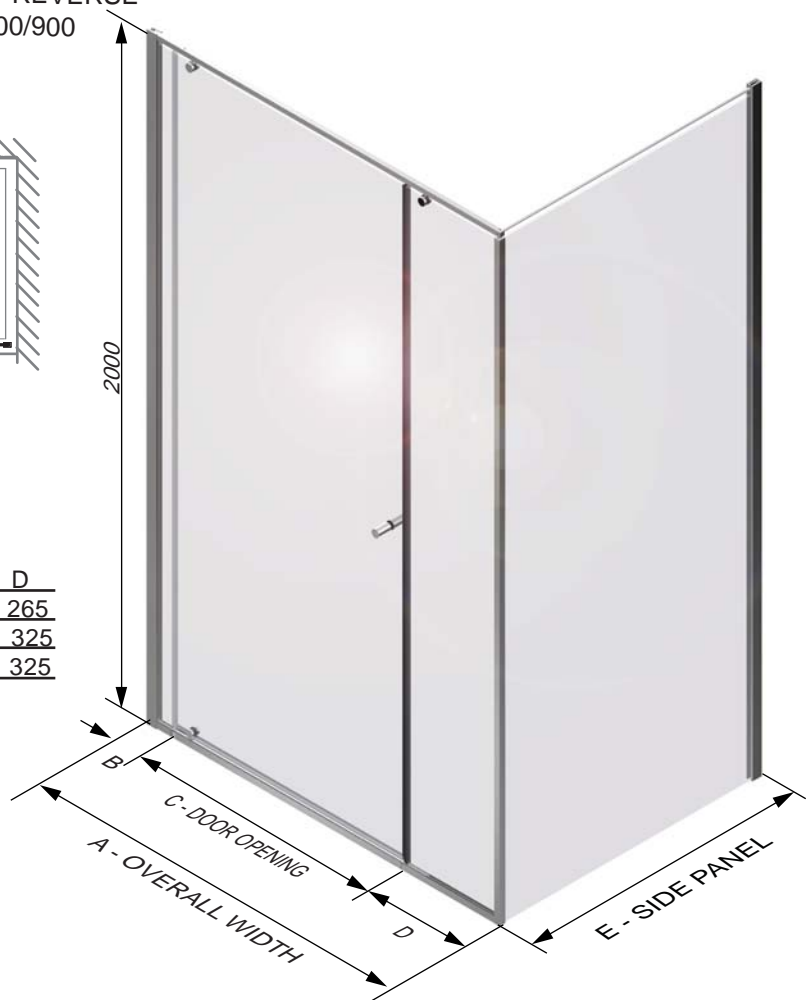

Dimensions are approximate

STAGE 1

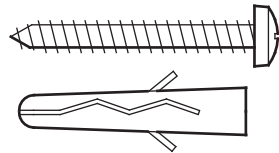

x 3 THIS PAGE SHOWS THE PANEL INSTALLATION FOR A LH CORNER. REVERSE FOR RH.
x 3

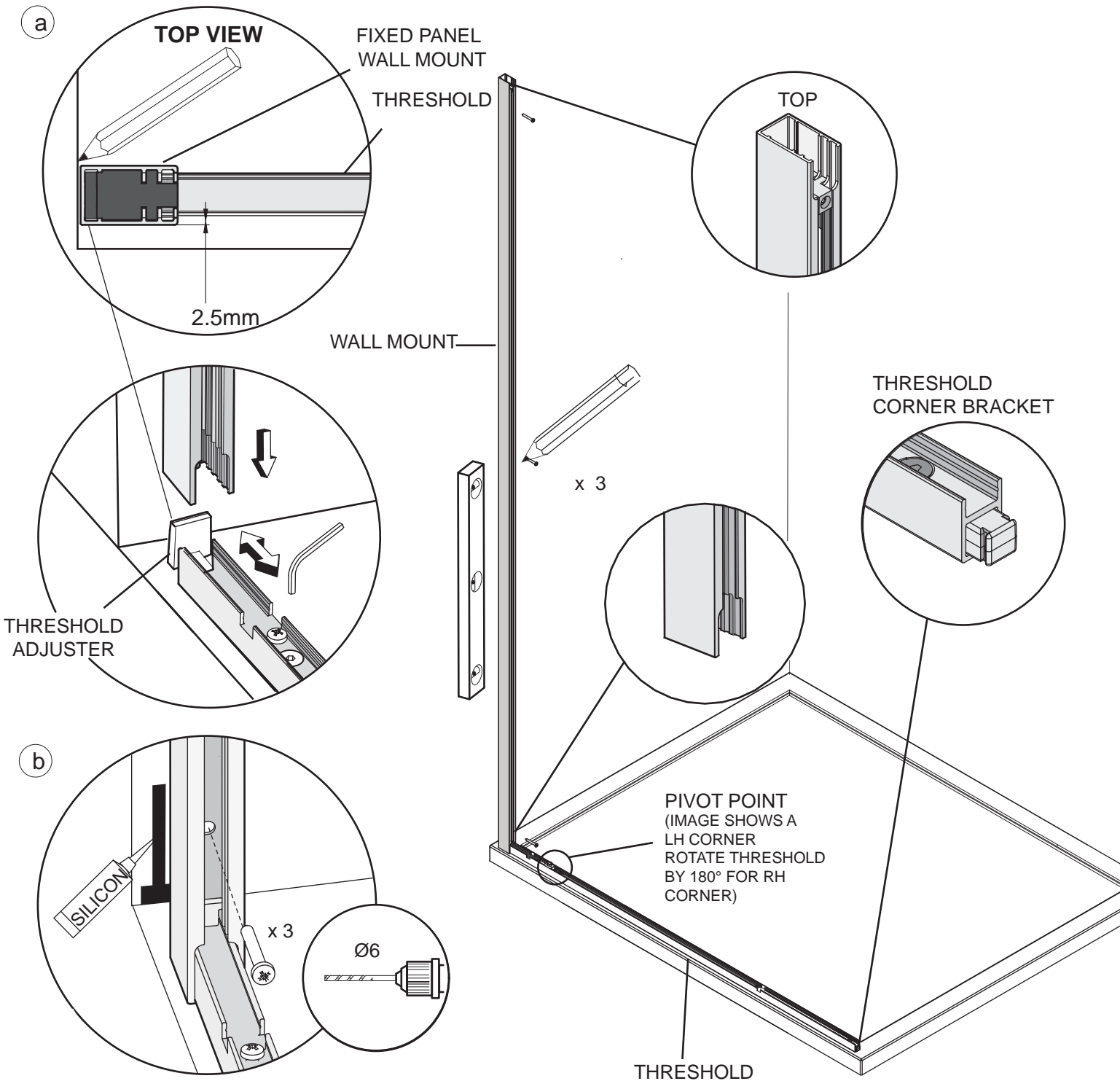

This stage is describing the fitting of the Fixed panel wall mount
Before fitting the enclosure please check that your product will fit the finished aperture size.(See dimensions)

a. Remove and set aside the threshold covers from the horizontal threshold. Place the horizontal threshold into position on tray, ensuring the threshold corner bracket is at the corner side of the enclosure (threshold extrusion is unhandled, rotate by 180° to reverse hand). The threshold extrusion should be positioned **as close to the outside edge of the tray as possible**, within the max and min side panel measurements (take into account that the front face of the fixed panel wall mount sits 2.5mm in front of the threshold when positioning at the front of the tray). Position the fixed panel wall mount on to the wall over threshold (wall mount has a top and bottom, wall mount cut-out with socket set screw is the top of the wall mount). Ensure the threshold adjuster fits up into the back of the wall mount extrusion in the recess as shown. Adjust position of threshold adjuster as required, to adjust loosen screw 1 full turn, re-tighten after adjustment, do not over tighten. Plumb the wall mount for upright and mark the fixing holes in the centre of the slots.

b. Drill 3 x fixing holes in the wall and insert wall plugs. Clean area and apply silicon sealant to the area behind the wall mount between the tray and tiles and 100mm up the wall, central to the width of the wall mount. Fit the wall mount using the No.8 x 32mm Pan Head Screws.

STAGE 2

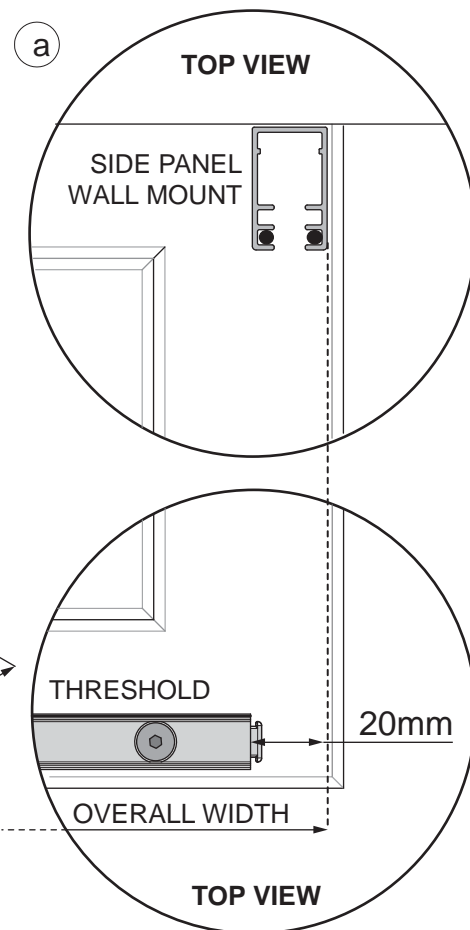
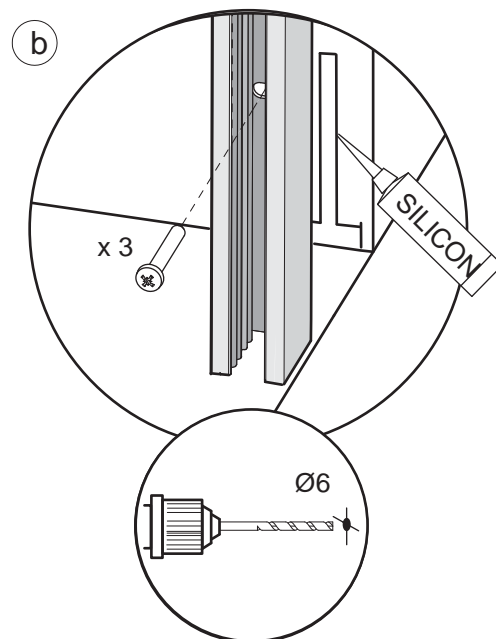
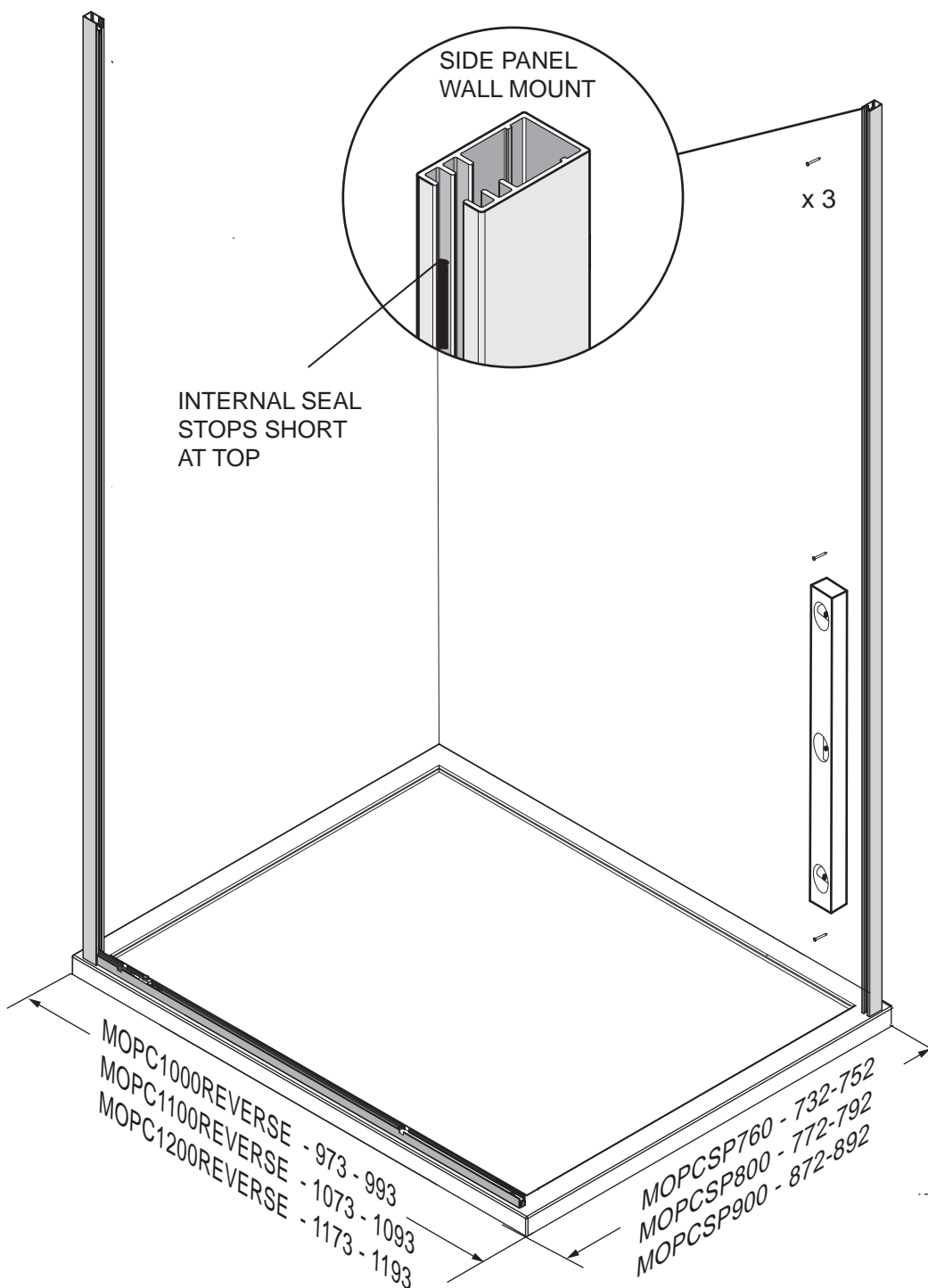
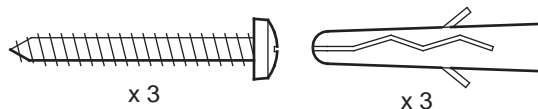

This stage is describing the fitting of the Side panel wall mount

Before fitting the enclosure please check that your product will fit the finished aperture size.(See dimensions)

a. Measure the distance from the wall side of the fixed panel wall mount to the end of the threshold and add 20mm, this gives you the measurement from the Wall side of the fixed panel wall mount to the outside face of the side panel wall mount. Mark position for side panel wall mount onto the wall. Check that this measurement is within the max and min width measurements. Position the side panel wall mount onto the wall. Plumb the wall mount for upright and mark the fixing holes in the centre of the slots.

b. Drill 3 x fixing holes in the wall and insert wall plugs. Clean area and apply silicon sealant to the area behind the wall mount between the tray and tiles and 100mm up the wall, central to the width of the wall mount. Fit the wall mount using the No.8 x 32mm Pan Head Screws

STAGE 3

THIS PAGE SHOWS THE PANEL INSTALLATION FOR A LH CORNER. REVERSE FOR RH.

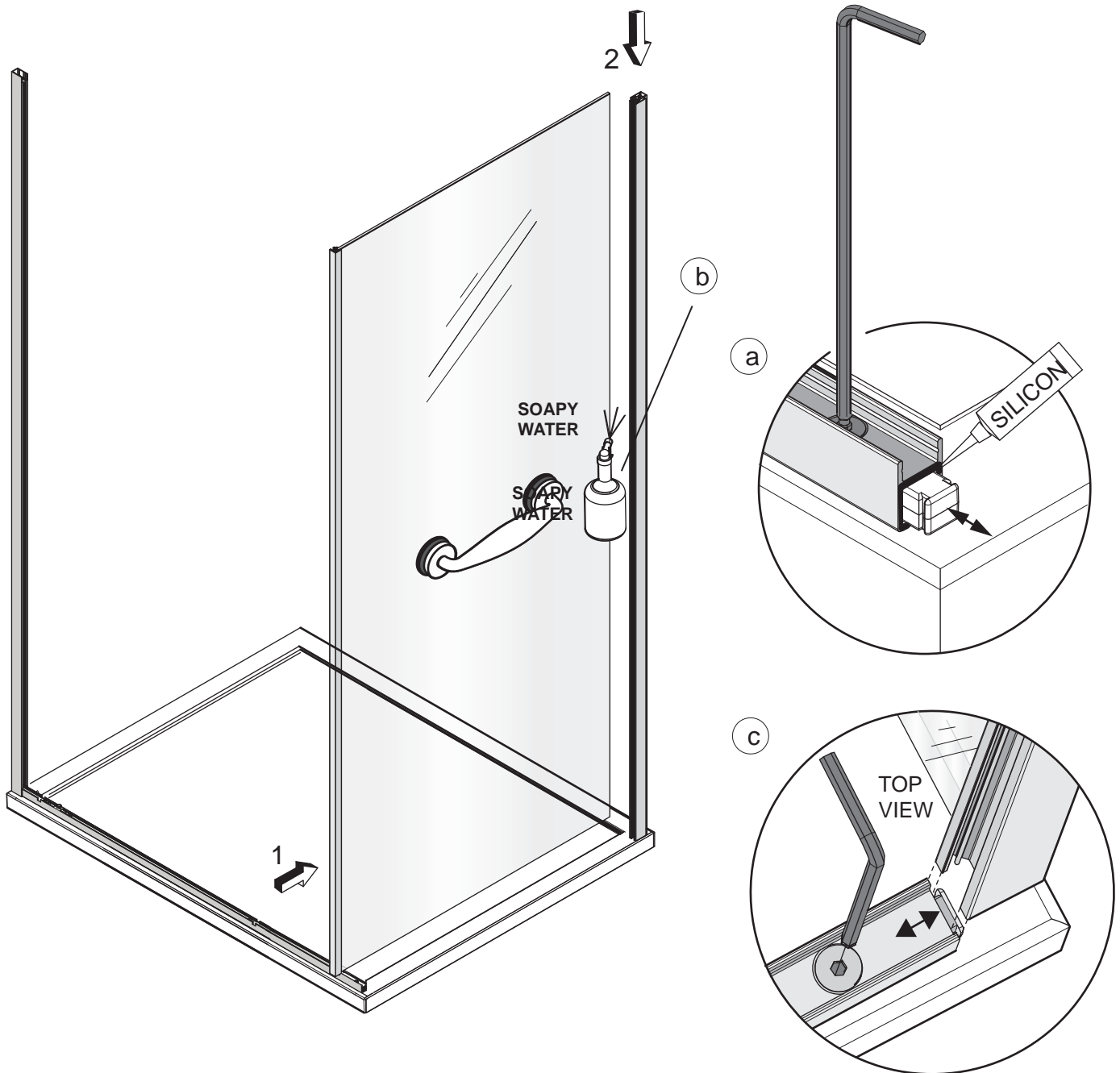

This stage is describing the fitting of the Side panel glass.

a. Loosen the threshold corner bracket using the 3mm allen key and adjust out for fitting.

a. Apply a bead of silicon around the exposed end face of the threshold track.

b. Lightly wet the edge of the side panel with soapy water and gently push the panel into side panel wall mount and down onto the finished floor/tray. Guiding the corner extrusion over the top of the threshold corner bracket. (Glass suction lifters required for this stage)

c. Tighten the threshold corner bracket into position.

STAGE 4

THIS PAGE SHOWS THE PANEL INSTALLATION FOR A LH CORNER. REVERSE FOR RH.

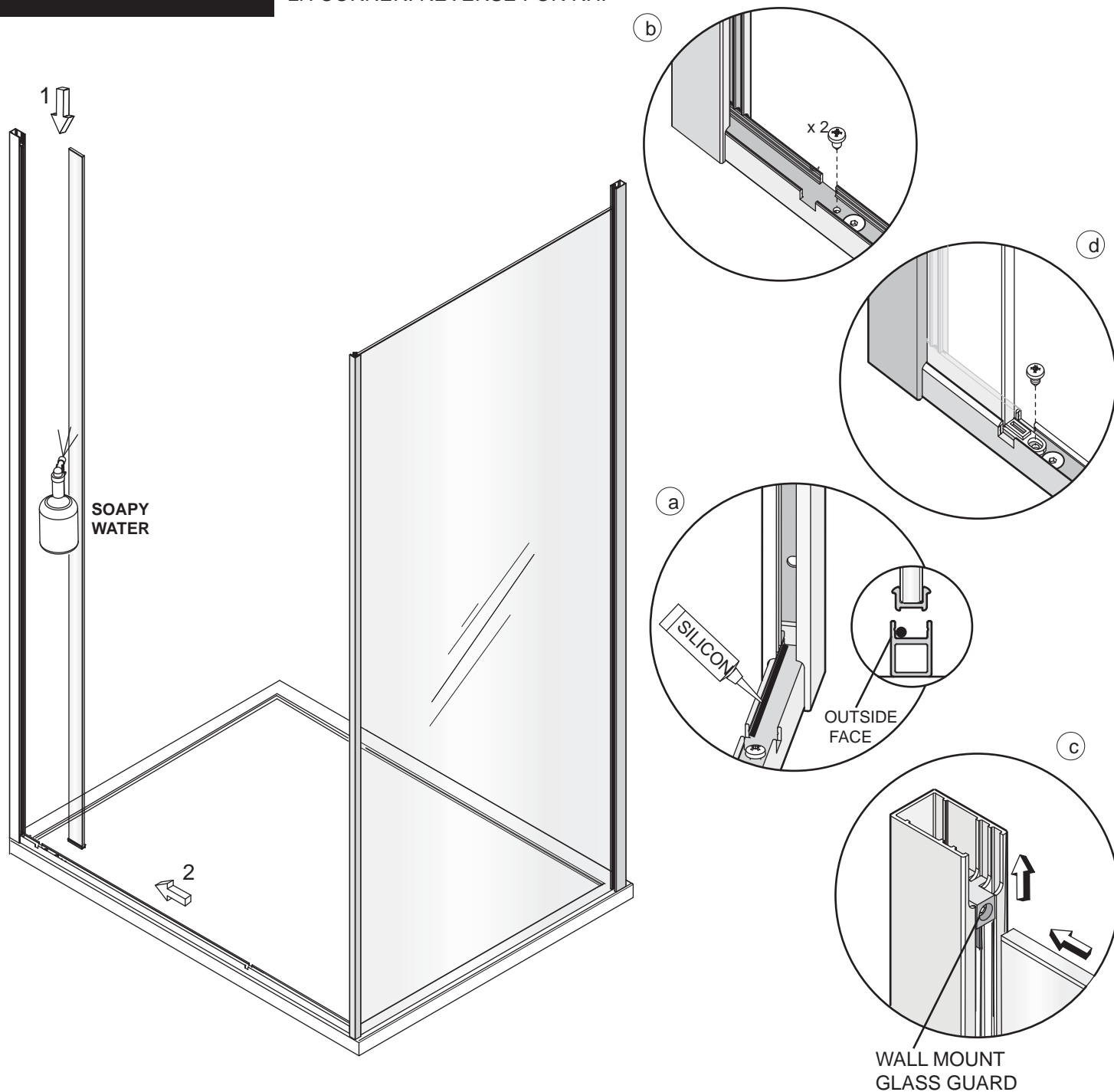

This stage is describing the fitting of the fixed panel for a LH Corner, reverse for RH Corner. Before fitting the fixed glass panel adjust the threshold extrusion so that the side panel is at right angles to the threshold extrusion. Loosen the threshold adjuster and lightly tighten in position as required.

- a.** Apply a bead of silicon along the outer inside edge of the threshold extrusion in the recess provided up to the cut-out where the fixed panel will be fitted.
- b.** Remove and set aside the panel stop fixing screws from the threshold extrusion.
- c.** Make sure the wall mount glass guard is pushed up fully to allow the glass to easily slot into the wall mount. Lightly wet the edge of the fixed panel with soapy water and gently lower the panel down into the threshold extrusion first then along into the wall mount.
- d.** As a guide the end of the edge of the fixed panel glass and extrusion should be positioned inline with the start of the cut out in the threshold track, further slight adjustments may be required during the fitting of the door. Fix into position using the previously removed screw.

STAGE 5

THIS PAGE SHOWS THE PANEL INSTALLATION FOR A LH CORNER. REVERSE FOR RH.

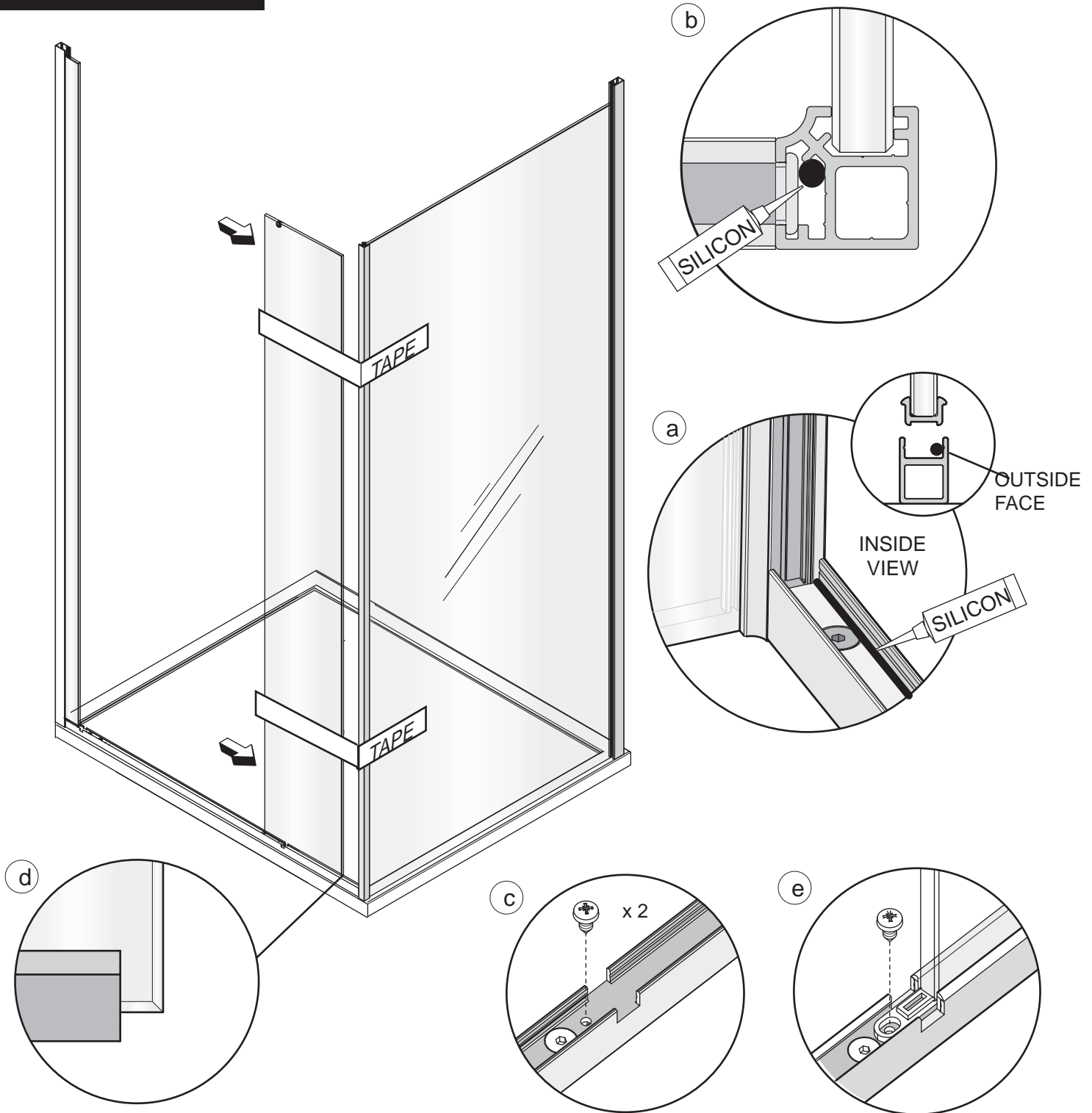

This stage is describing the fitting of the closure panel for a LH Corner, reverse for RH Corner.

- a.** Apply a bead of silicon along the outer inside edge of the threshold in the recess provided.
- b.** Apply a bead of silicon in the corner extrusion as shown, down the full length of the corner extrusion.
- c.** Remove and set aside the panel stop fixing screws from the threshold extrusion.
- d.** Gently lower the panel down into the threshold extrusion first then along into the corner panel extrusion, the extrusion on the bottom of the closure panel is offset, the exposed glass edge fits into to the corner extrusion.
- e.** As a guide the end of the edge of the fixed panel glass and extrusion should be positioned inline with the start of the cut out in the threshold track, further slight adjustments may be required during the fitting of the door. Fix into position using the previously removed screw.

STAGE 6

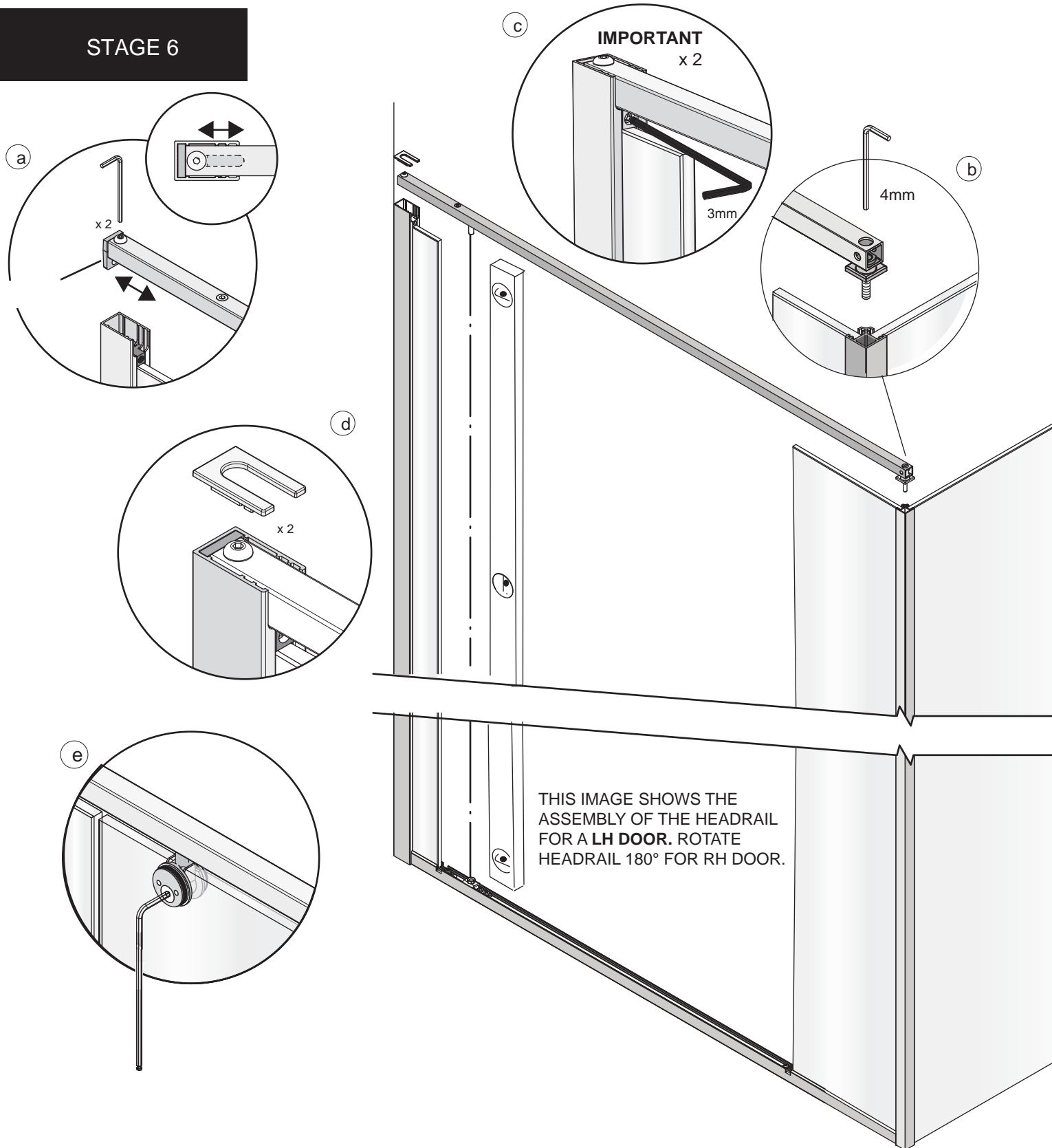

This stage is describing the fitting of the Top Track.

- a.** Loosen the fixings in the headrail adjuster to allow the adjuster to move freely in and out. Lower the top track into position, ensuring the tongue on the headrail adjuster fit down into the back of the wall mounts. Using a long spirit level align the upper and lower pivot points by adjusting the headrail left or right. Re-tighten the fixing in the headrail adjuster to fix in position.
- b.** Fix the Corner frame fixing to the Corner frame using the pre-assembled screw.
- c. Important** - tighten the top track locking screw underneath the top track on fixed panel wall mount to fix the top track to the wall mount.
- d.** Fit the wall mount top cap (supplied in the kit of parts) to the top of the wall mount.
- e.** Tighten the inline panel clamp to the headrail.

STAGE 7

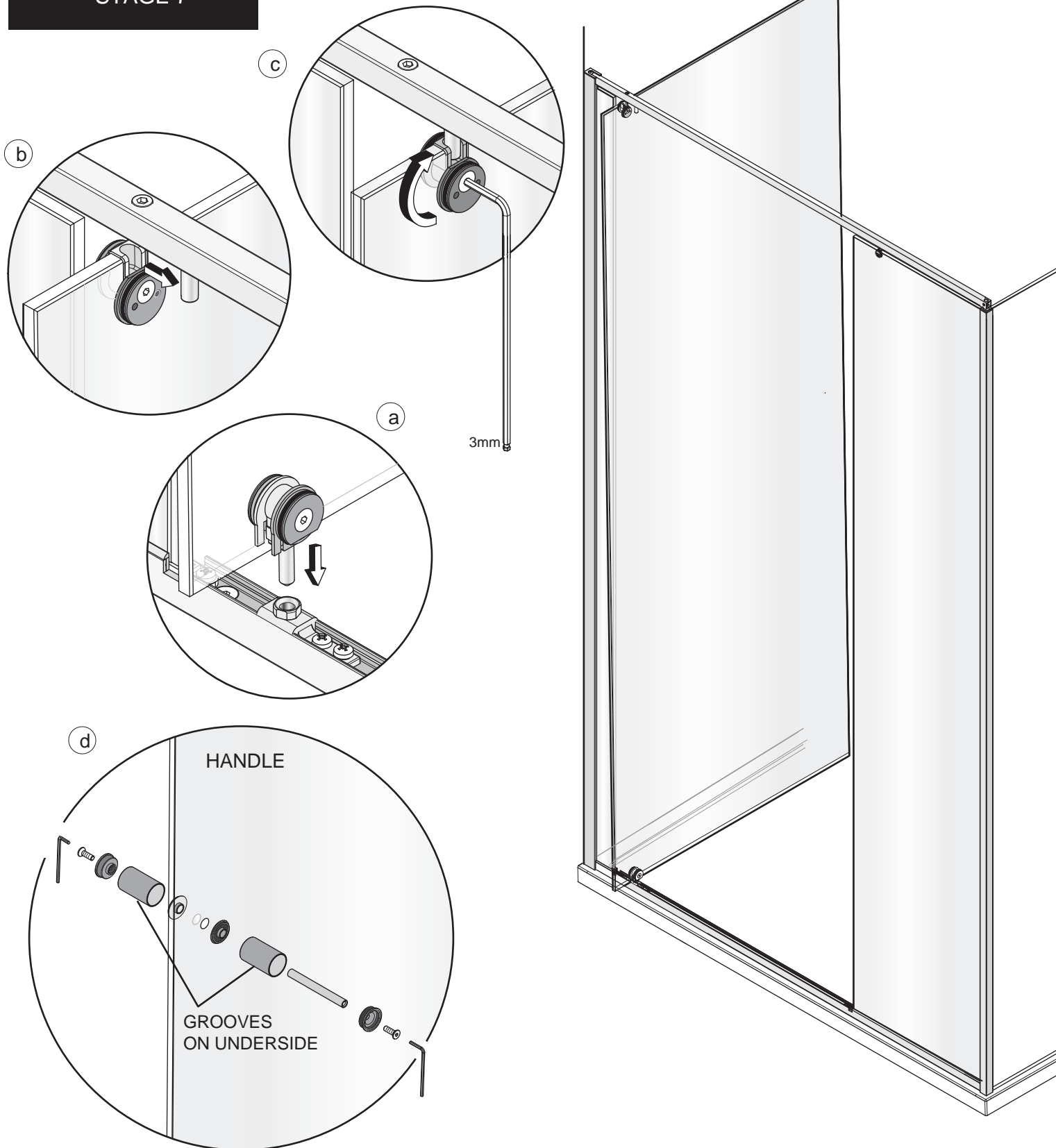

This stage is describing the fitting of the Door.

a. Lift the door and carefully guide the lower pivot block pin into the pivot block fitted to the threshold track.

b. From behind guide the upper pivot block pin fixed to the headrail into the cup in the pivot block fitted to the top of the door.

c. Rotate the pivot block disc with the socket csk screw 180° so that it secures the door in position. Tighten the socket csk screw.

d. Disassemble the handle by unscrewing the 2 x M5 x 12 Csk socket screws. Place the glass washers either side of the 2 holes in the door glass. Re-assemble the handle to the glass and tighten into position with the grooved surfaces on the handle on the underside.

STAGE 8

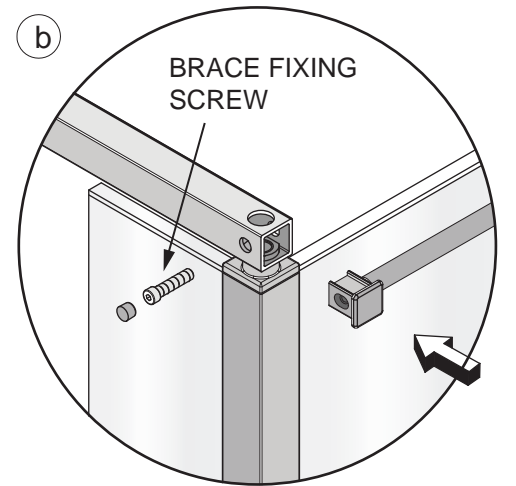
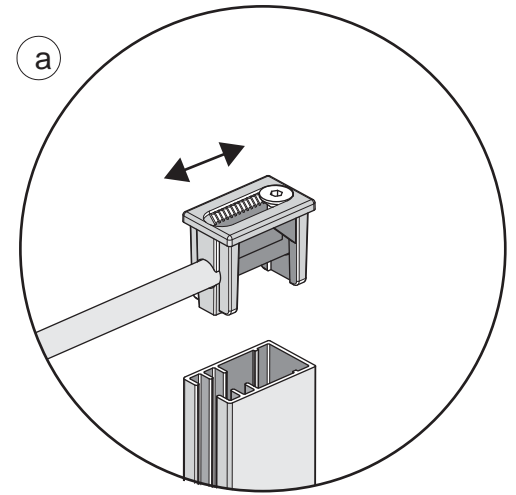
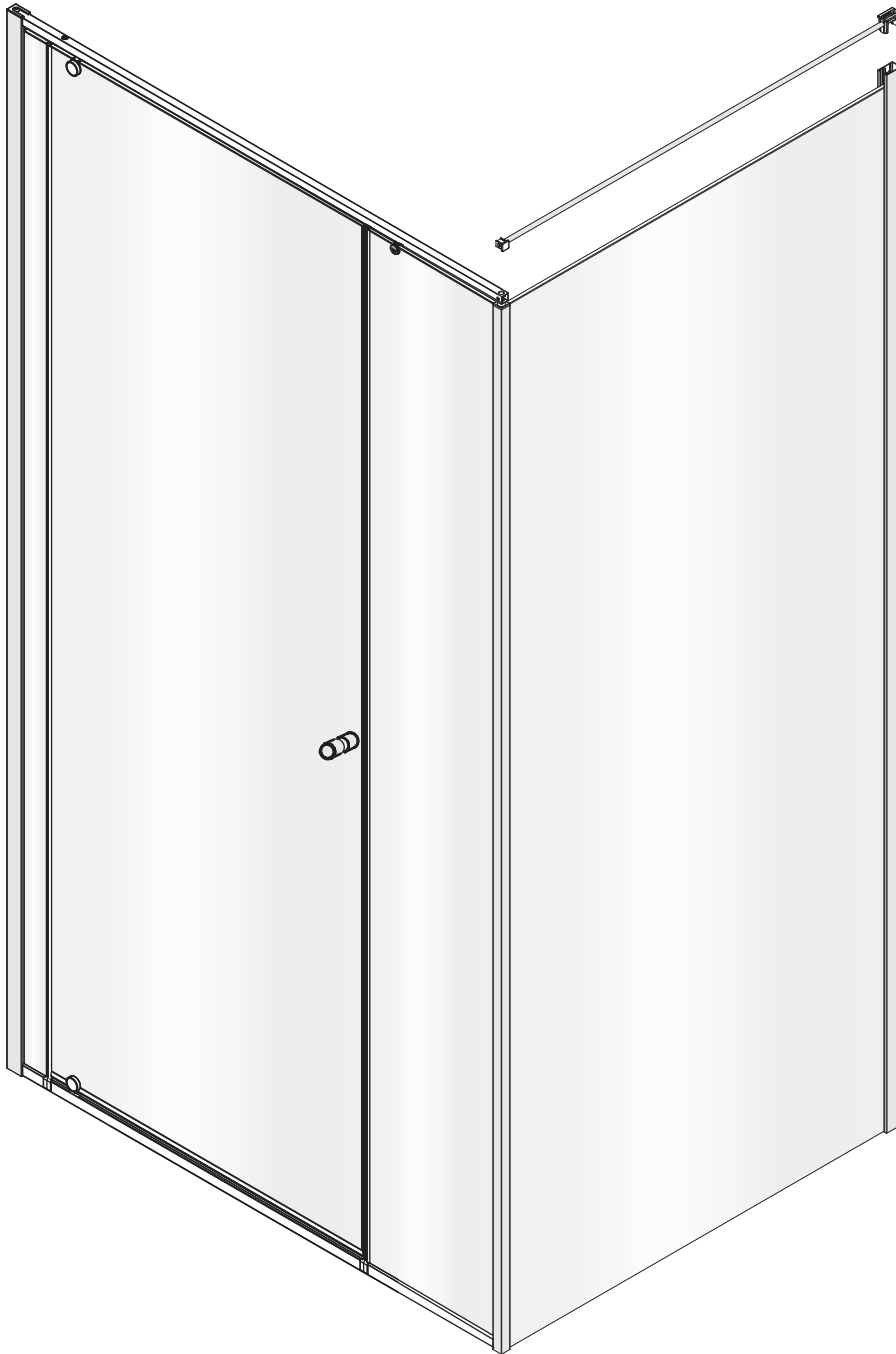

This stage is describing the fitting of the side panel brace

- a.** Fit the Corner brace by locating the top cap into the side panel wall mount, adjust as required.
- b.** Remove the brace fixing screw at the end of the brace bar and push fit the cap into the end of the top track, fix into position using the brace fixing screw. Insert the screw cover into front face of top track (supplied in kit of parts).

STAGE 9

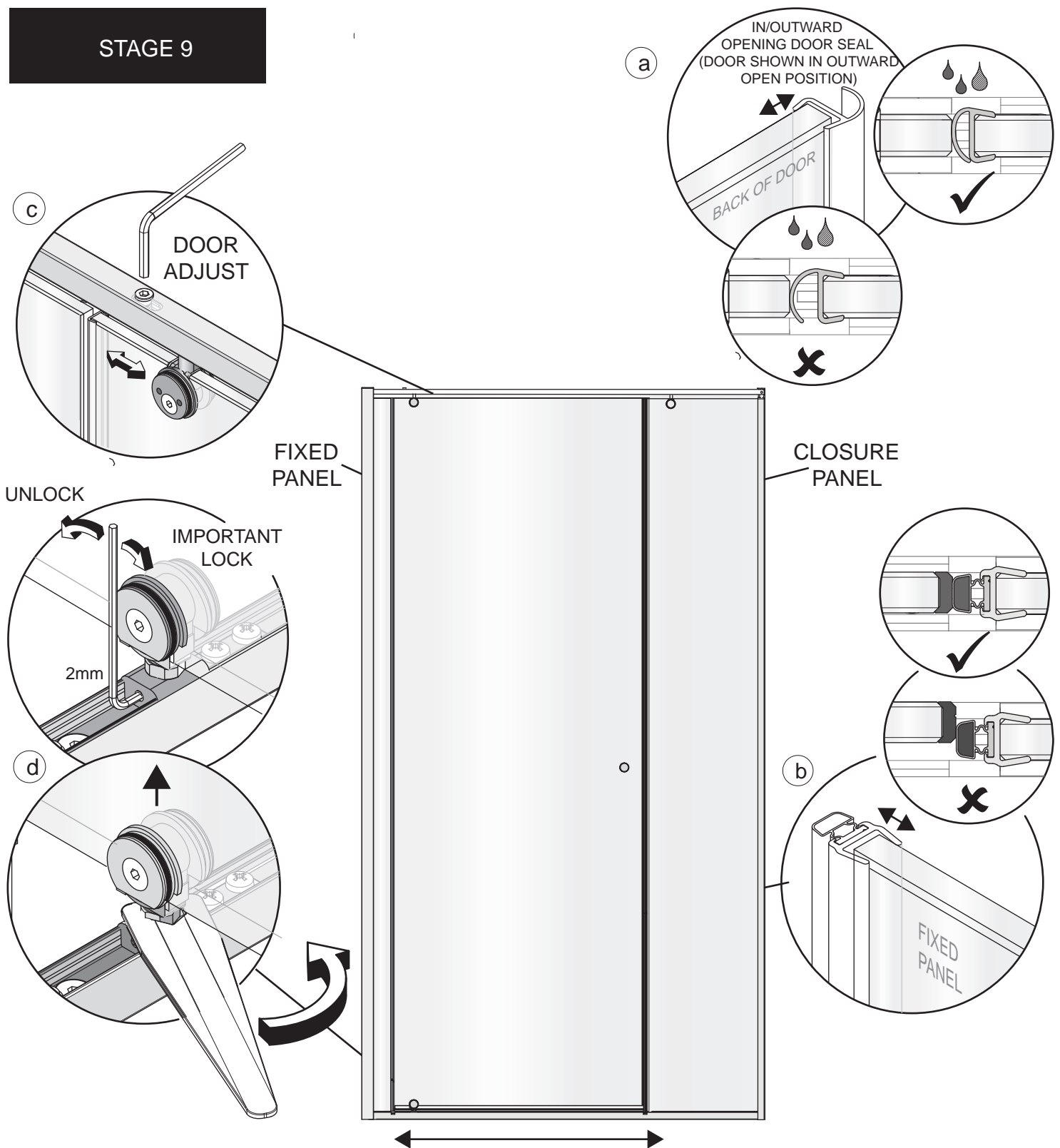

This stage is describing the Door adjustment.

a. Fit the door closure seal to the back of the door. The door closure seal can be adjusted away from the edge of the door to improve sealing with the fixed panel or the fixed panel can be adjusted at the top to the seal. **Important. The inward/outward seal requires sufficient compression to the fixed panel glass.** When initially opening the door both inwards and outwards the seal may deform unevenly and can catch the fixed panel. Allow the seal to take a set in the closed position for 12 -24 hrs. Open the door inwards and outwards adjust as required ensuring the seals works effectively for both directions of movement.

b. Fit the magnetic closure panel seal to the edge of the closure panel. Check the polarity of the magnet is correct with the magnet on the edge of the door. This seal can be adjusted away from the edge of the fixed panel to meet the door magnetic seal or the fixed panel can be adjusted at the top to the door. Check there are no gaps between the door and magnetic closure panel seal.

c. To adjust the door left to right at the upper pivot point, loosen the socket cap screw in the top of the headrail by one turn only and adjust the door as required.

d. To adjust the door up and down at the lower pivot point, firstly loosen the locking screw in the lower pivot block. Then using the spanner (supplied in the kit of parts) wind the nut at the base of the pivot block anti-clockwise to raise the door upwards. **Important - Re-tighten locking screw**

STAGE 10

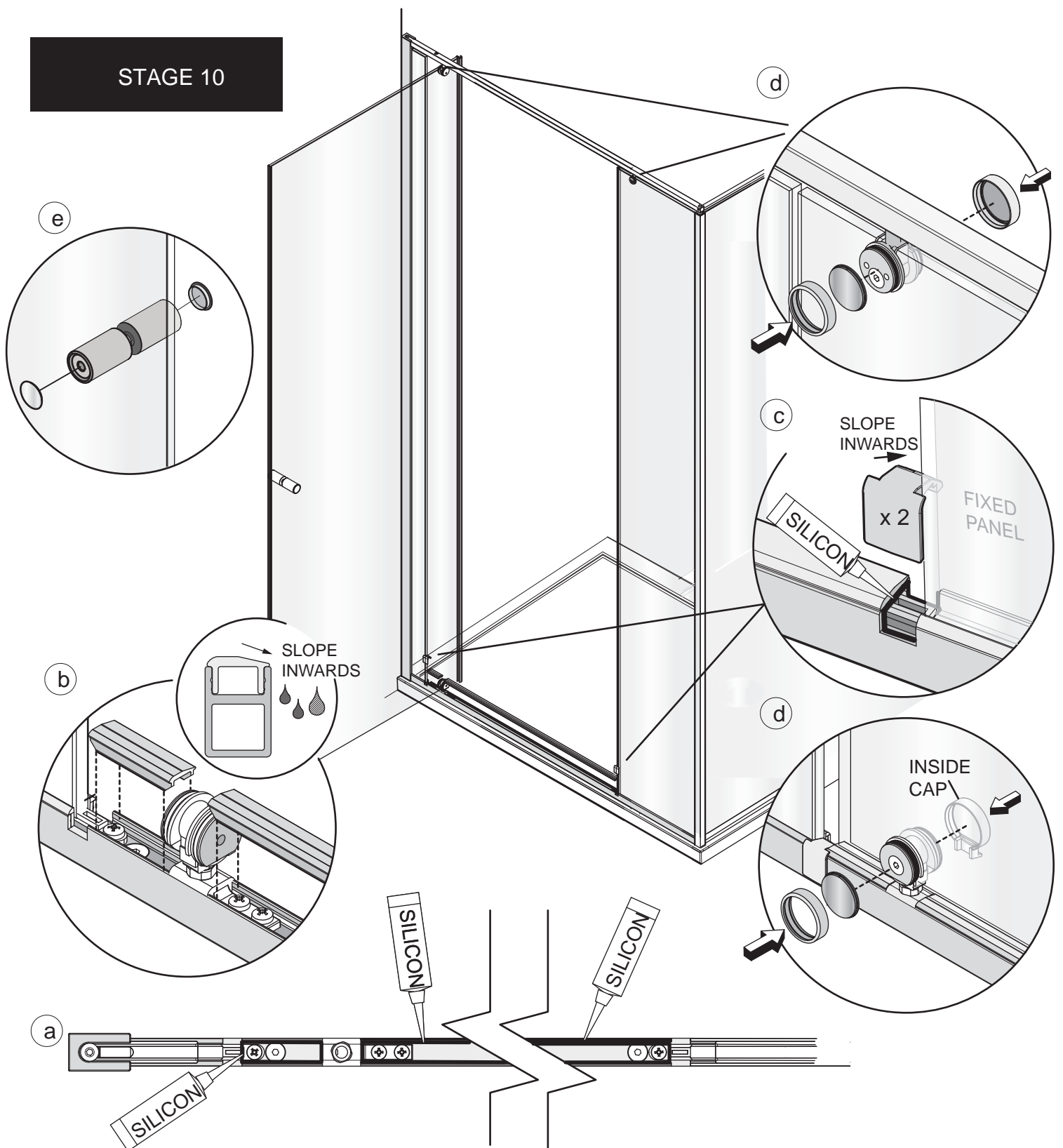

This stage is describing the fitting of the covers and caps.

a. Apply a continuous bead of silicon all around the inside of the troughs in the threshold track between the edge of the fixed panel and the lower pivot block and between the other side of the lower pivot block and edge of the closure fixed panel, as shown above.

b. Fit the two covers either side of the lower pivot block into the threshold track, so that the face of the covers is firmly pressed against the face of the lower pivot block and ensure the slope on the cover is facing inward.

c. Apply a bead of silicon all around the inside of the recess in the threshold track where the threshold cover caps are to be fitted, from the edge of the threshold cover all the way around to the edge of the fixed glass panel. Fit the threshold cover caps (supplied in the kit of parts), with the slope facing inwards.

d. Fit the upper pivot block covers with colour detail disks over both sides of the upper pivot block and inline panel clamp. The inline panel clamp covers are factory fitted on the panel for silver, black and white units. Remove and refit with the colour disks. The Inline clamp covers are not fitted on bronze products or with optional copper and brass handle variants. These are included in the parts kit.

e. Fit the handle cover caps, press firmly into the ends of the handle.

STAGE 11

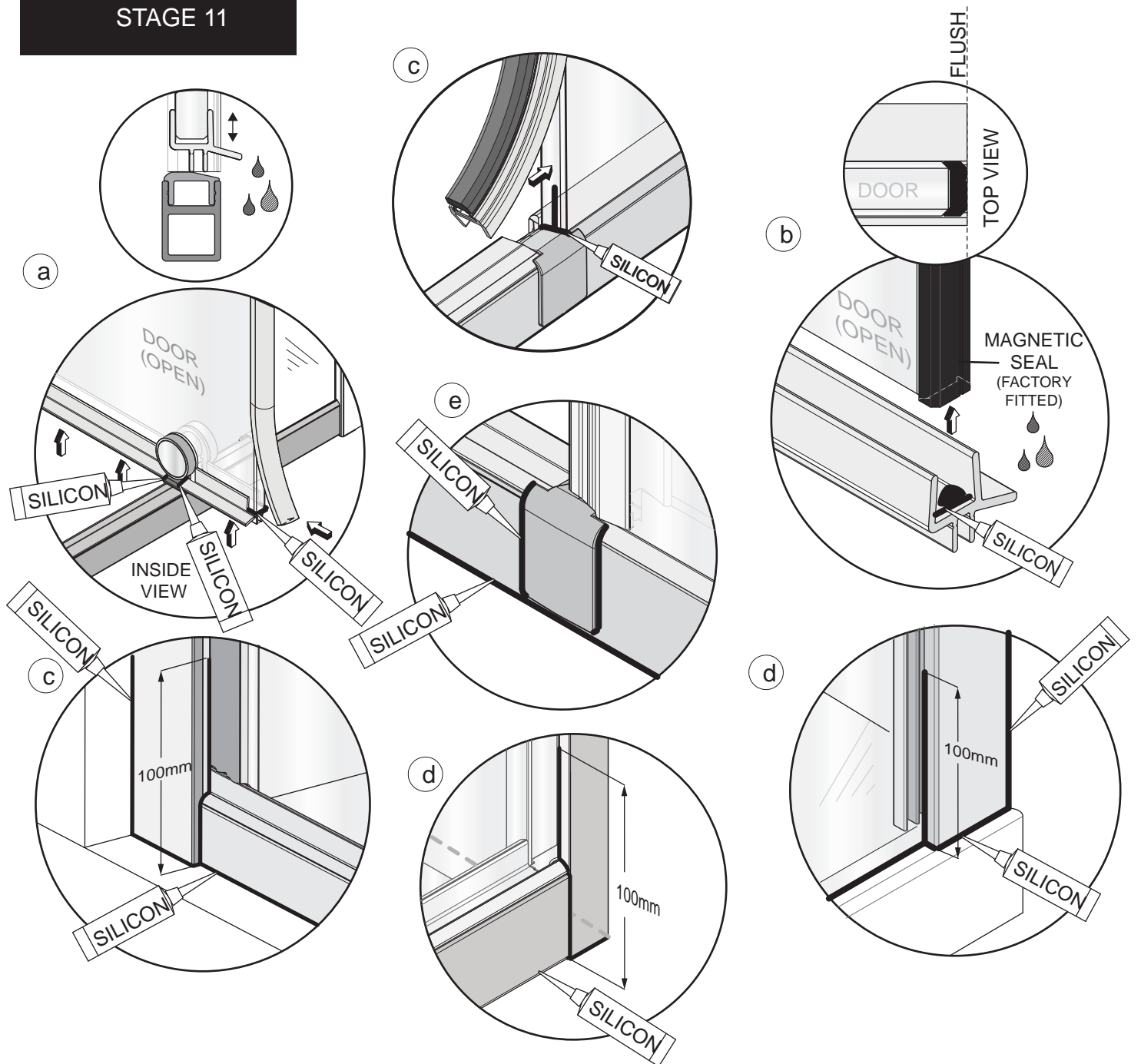

This stage is describing the final fitting of the Seals and Silicon

- a.** Fit the door horizontal seals to the bottom of the door, ensuring that the ends of the seal are firmly pressed up against the side of the lower pivot block on both sides. The horizontal seal deflector faces inwards. Adjust the Horizontal door seals down as required to meet the threshold. Pull off the vertical seal at the bottom on the pivot side and apply a bead of silicon sealant at the end of the horizontal seal, refit the vertical seal. Apply a small bead of silicon to the joints where the horizontal seals meet the inside pivot block cap.
- b.** The end of the horizontal seal must be flush with the edge of the door. Apply a bead of silicon sealant between the bottom of the door and the horizontal seal, clean the silicon flush with the door edge.
- c.** Pull off the closure panel vertical magnetic seal at the bottom. Apply a bead of silicon along the top of the threshold cover cap and vertical edge of the glass panel and refit the magnetic seal to the edge of the glass.
- d.** Apply a thin bead of silicon along the bottom edge of both the wall mounts and all the way up the outside of both the wall mounts and the tiles. Apply a thin bead all the way along the threshold between the extrusion and finished floor surface/tray and the side panel glass where it meets the finished floor surface/tray. Continue around the joint where the threshold joins the wall mounts and also 100mm up on the outside where the wall mount and glass meet. Continue the silicon around the corner joint where the threshold meets the corner extrusion and also 100mm up on the outside where the corner extrusion and glass meet.
- e.** Apply a bead of silicon on the outside around the joints between the threshold cover caps and threshold extrusion. Masking tape can be used to achieve a tidy edge to the sealant. Remove the masking tape immediately and allow the silicon to cure for 24 hours before using the shower.

PARTS LIST

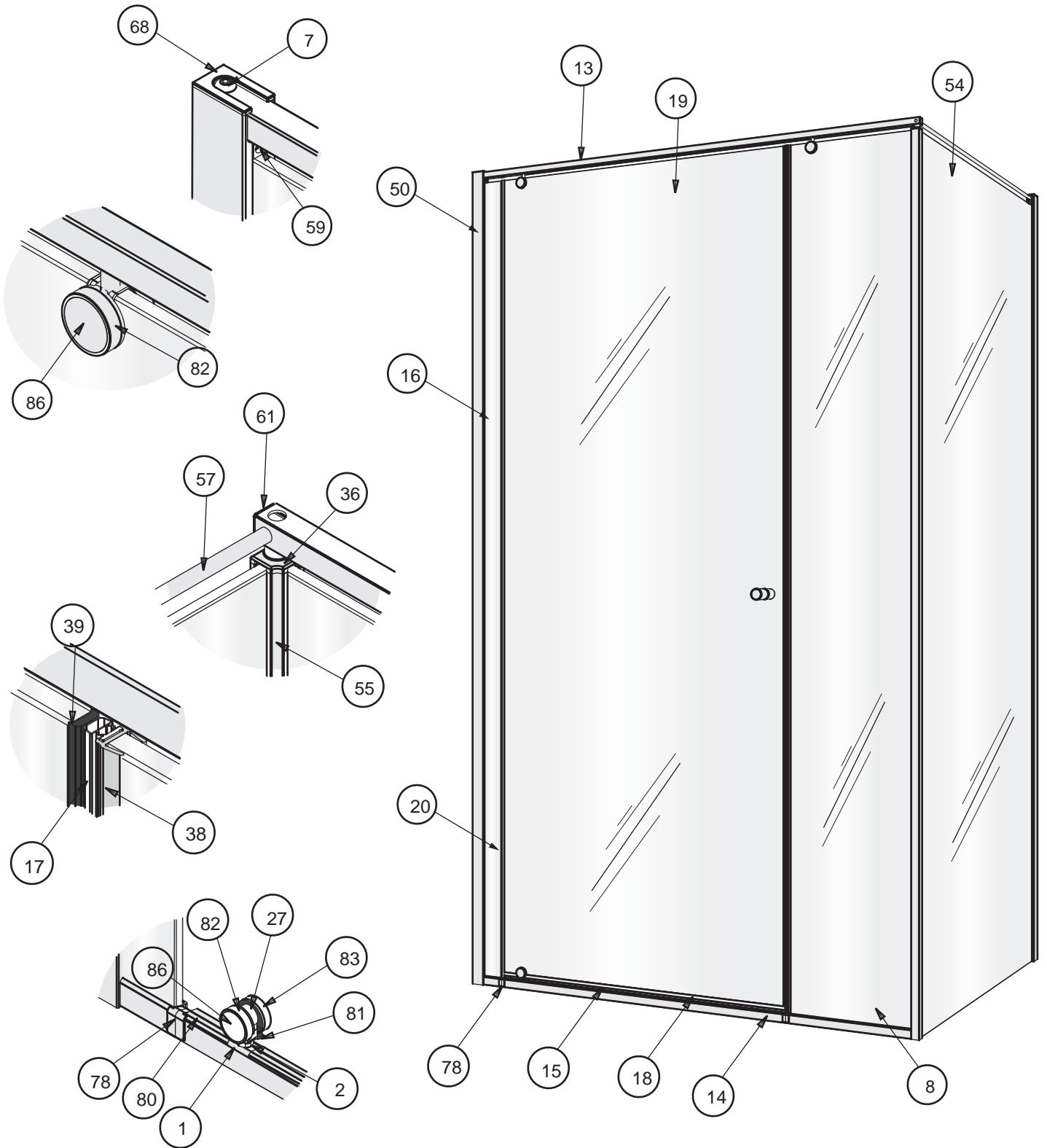

PIVOT DISK KIT OF PARTS

ITEM	DESCRIPTION	PART No	QTY
*81	DECORATIVE PIVOT DISK WITH SEAL	8440 A SILVER	1
82	DECO DISK COVER RING	8252 A SILVER	3
83	DECO DISK COVER RING WITH CUT OUT	8269 A SILVER	1
*84	DECORATIVE HANDLE CAP	8400 A SILVER	2
85	DIN O-Ring 0140-20	8582 AF	2
*86	DECORATIVE PIVOT DISK	8652 A SILVER	5
87	MTK1 PIVOT & QUINT DISK DISPLAY PACK	4682 AF	1
88	MATKI CHROME EMBLEM	1005 CHROME	1

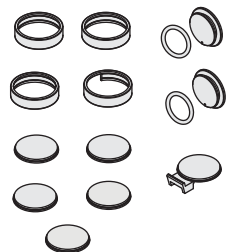

PARTS LIST

* colour variant on parts

MAIN PIVOT PACK

ITEM	DESCRIPTION	PART No	QTY
1	PIVOT BLOCK	8423 AF	1
2	PIVOT HEIGHT ADJUSTER	8258 AF	2
3	DIN 916 M4 X 8 SOCKET SET SCREW ST.ST	1360 A SILVER	1
4	PIVOT BLOCK ADJUSTER SCREW	8262 AF	1
5	ADJUSTER CLAMP	8427 AF	4
6	TOP WALL CORNER BRACKET	8452 AF	1
7	M5 X 12 SOCKET DOMED ST.ST	1282 A SILVER	1
8	PIVOT CLOSURE PANEL	7657 M CLEAR/PLAIN	1
9	PIVOT CLOSURE PANEL RAIL	8426 A SILVER	1
10	No.8 x 9.5 PAN POZI S.TAP ST.ST	1420 A SILVER	2
11	BOTTOM WALL CORNER BRACKET	8431 AF	1
12	SLIDER PANEL BOTTOM CORNER BRACKET	8443 AF	1
13	INLINE CORNER TOP BAR	8551 A SILVER (1000) / 8552 A SILVER (1100) / 8553 A SILVER (1200)	1
14	INLINE CORNER FLOOR RAIL	8583 A SILVER (1000) / 8584 A SILVER (1100) / 8585 A SILVER (1200)	1
15	CORNER INLINE FLOOR RAIL COVER	8556 A SILVER (1000) / 8557 A SILVER (1100) / 8558 A SILVER (1200)	1
16	INLINE CORNER PANEL	7670 M CLEAR/PLAIN (1000) / 7671 M CLEAR/PLAIN (1100,1200)	1
17	PIVOT DOOR MAGNET	8679 AF	1
18	HORIZONTAL DOOR SEAL	8598 CLEAR	1
19	CORNER DOOR	7659 M CLEAR/PLAIN (1000) / 7660 M CLEAR/PLAIN (1100) / 7661 M CLEAR/PLAIN (1200)	1
20	PIVOT V DOOR CLOSURE SEAL	8618 AF	1
21	TOP PIVOT BLOCK	8422 A SILVER	1
22	PIVOT SLEEVE TOP	8413 GREY	1
23	TOP PIVOT GUARD	8417 GREY	1
24	PIVOT BLOCK CAP	8254 A SILVER	2
25	DIN O-Ring 0190-20	8579 AF	6
26	M5 X 20 CSK SOCKET SCREW ST.ST	1503 A SILVER	3
27	PIVOT PIN	8421 AF	1
28	PIVOT DISK WITH COUNTERSINK	8255 A SILVER	1
29	PIVOT DISK WITH BOSS	8256 A SILVER	1
30	BOTTOM PIVOT GLASS BUSH	8414 GREY	1
31	BOTTOM PIVOT GLASS BUSH 2	8418 GREY	1
32	TOP PIVOT PIN	8253 AF	1
33	ADJUSTING PIVOT BLOCK	8589 A SILVER	1
34	M5 x 10 CSK SKT	1488 A SILVER	2
35	CORNER INLINE PANEL GLASS RAIL	8554 A SILVER (1000) / 8555 A SILVER (1100,1200)	1
36	CORNER CAP	8424 A SILVER	1
37	PIVOT CORNER HEADRAIL SCREW	8268 AF	1
38	PIVOT DOOR MAGNET CARRIER	8762 CLEAR	1
39	PIVOT DOOR CLOSURE MAGNET C0923	8645 AF	1
40	BS4518 O-Ring 0041-16	8680 AF	1
41	INLINE NOTCH CLAMP BODY	8404 GREY	1
42	INLINE NOTCH CLAMP GUARD	8403 GREY	1
43	INLINE PIVOT BLOCK CAP	8401 A SILVER	1
44	QUINTESSA NOTCH CLAMP PIN	8639 AF	1
45	DIN 557 M6 SQUARE NUT ST.ST		1
46	DIN 916 M4 X 5 SOCKET SET SCREW ST.ST	1297 A SILVER	2
47	MATKI ONE CORNER INLINE PIVOT INSTALLATION INSTRUCTIONS	0948 AF	1
48	MATKI ONE PIVOT KIT OF PARTS	7364 A SILVER (7373 BRASS / 7373 COPPER)	1
49	PIVOT CORNER CLOSURE PANEL RAIL	8678 A SILVER	1

PANEL PIVOT PACK

ITEM	DESCRIPTION	PART No	QTY
*50	PIVOT WALL MOUNT	7628 A SILVER/BLACK/WHITE BRONZE	1
51	PIVOT SIDE PANEL CORNER	7638 A SILVER	1
52	CORNER INTERNAL FIXING BLOCK	8430 A SILVER	2
53	NRP M4 X 10 SKT SET ST/ST	1295 A SILVER	2
54	PIVOT SIDE PANEL GLASS	7666 M CLEAR/PLAIN (760) / 7667 M CLEAR/PLAIN (800) / 7668 M CLEAR/PLAIN (900)	1
*55	SIDE PANEL WALL MOUNT	7606 A SILVER/BLACK/WHITE/BRONZE	1
56	PIVOT SIDE PANEL WALL MOUNT CAP	8405 A SILVER	1
57	SIDE PANEL BRACE	7648 A SILVER (760) / 7646 A SILVER (800) / 7647 A SILVER (900)	1
58	WOO 1200 M5 X 16 CSK SOCKET HD ST/ST	1495 A SILVER	1
59	WALL MOUNT LOCKING SCREW	8266 AF	2
*60	WALL MOUNT GLASS GUARD	8415 GREY/WHITE/BLACK	1
61	PIVOT TOP END CAP	8590 A SILVER	1
62	BS nsp 5mm DIA FOAM CORD INSERT	1752 AF	8
*63	MATKI ONE PIVOT DISK KIT OF PARTS (DETAIL PACK)	7366 (SILVER/BLUE/GREEN/RED/GOLD/COPPER/BRASS) WHITE/BLACK)	1

PIVOT KIT OF PARTS

ITEM	DESCRIPTION	PART No	QTY
64	WALL PLUG	1818 AF	6
65	3mm AF BALL END	8622 AF	1
66	2mm ALLEN KEY	1286 AF	1
67	4mm ALLEN KEY	1166 AF	1
68	WALL MOUNT TOP CAP	8441 A SILVER	2
69	HANDLE WASHER	8439 GREY	2
70	HANDLE CAP WASHER	8257 A SILVER	2
71	HANDLE CENTRAL BAR	8250 A SILVER	1
72	N.08 x 38 PAN HEAD POZ S TAP ST/ST	1210 A SILVER	6
73	BRACKET HOLE COVER	7461 A SILVER	1
74	111 10mm OPEN-END SPANNER	7599 AF	1
75	CLEAR MATKI SEALANT 78G WITH LOGO	1967 AF	1
76	M5 X 12 CSK SKT SCREW	1417 A SILVER	2
77	PIVOT DOOR HANDLE SLEEVE	8641 A SILVER	2
78	RAIL CAP	8677 A SILVER	2
79	PIVOT SIDE HORIZONTAL SEAL	2435 CLEAR	1
80	PIVOT THRESHOLD COVER SMALL	7629 A SILVER	1

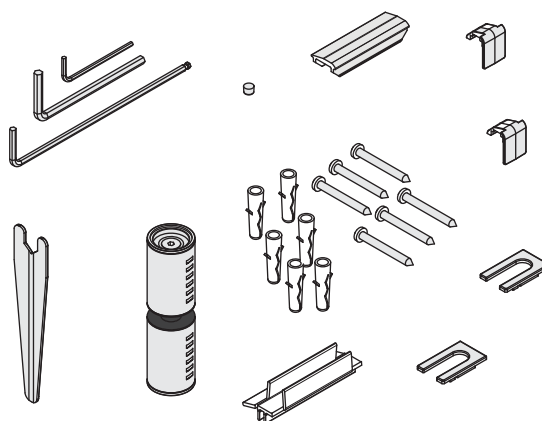

MAINTENANCE

Matki Glass Guard Easy Clean Surface Protection (optional) and General Cleaning Guide

Cleaning Instructions

Matki Glass Guard allows water to form minute beads which easily trickle off the surface of the glass. This makes the glass easier to clean - the glass does not need to be cleaned as frequently, but it does require occasional maintenance. As less cleaning is required the use of detergents can be minimised thus helping to protect the environment. The lifespan of the Matki Glass Guard is dependant on the frequency of use of the shower and the degree of water hardness.

The combination of alkaline materials and humidity affects glass in an extremely aggressive way. Do not use bleach, alkaline, acid-based or aggressive and abrasive glass cleaners, detergents or household cleaning products on the glass or frames.

We recommend that glass is washed down with clean water and a soft clean cloth or sponge and dried off with a microfibre cloth.

The special coating is only present on the inside of the glass.

Matki Glass Guard is guaranteed for 2 years provided that the guidelines and cleaning instructions are followed.

Aluminium and Chrome parts should be cleaned with a mild non scratch household cleaner and a soft cloth or sponge.

Do not use acidic-based descaler products or products which are unsuitable for cleaning enamelled surfaces, including abrasive cleaners or cleaners containing bleach or solvents, as the products will effect the anodised framework. Under no circumstances use cleaners with a pH level exceeding 8.

Matki does not recommend the use of 'Leave-on' shower cleaners on Matki Glass Guard Products.

Water Softeners and Glass Guard - Certain types of water softeners increase the alkalinity of the water due to a carry-over of Chloride during re-generation which can cause aggressive water spots on both untreated and Glass Guarded glass. If using a water softener we recommend a two-cylinder machine with automatic re-generation instead of a timer. If a single-cylinder water softener with timer is already installed it is recommended that after each shower excess water is removed from the glass with a squeegee or with a micro-fibre cloth.

Annual recommended maintenance - Matki recommend annually lubricating the barrel of the hinge with a lubricating spray such as WD-40 to remove dust build-up and to aid the movement of the hinge.



Wash down with clean warm water and a soft clean cloth or sponge.

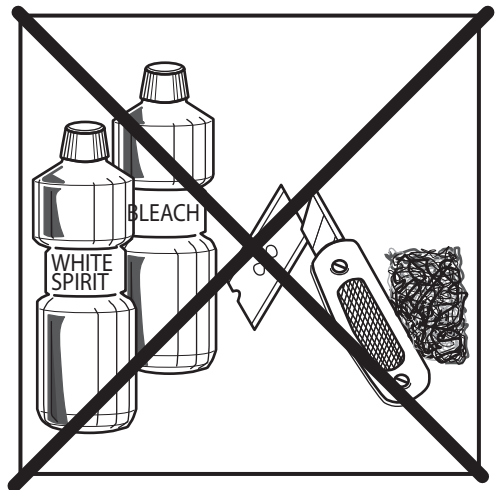

Do not use bleach, alkaline or acid-based, aggressive or abrasive cleaning products.

Flash Bathroom Spray or Cif Bathroom Spray can be used on Matki Products.
Read manufacturers label before using any cleaning materials.

IMPORTANT

Matki Glass Guard is guaranteed for 2 years. It is essential that the cleaning instructions are followed in order to maintain the hydrophobic properties of the glass coating. In the event of the failure to comply in any way with these instructions, any warranty or guarantee will be null and void.

MATKI PLC, CHURCHWARD ROAD, YATE, BRISTOL, BS37 5PL
TELEPHONE:01454 328816 (AFTER SALES) FAX:01454 328821 EMAIL: techsupport@matki.co.uk

CE

matki | SHOWERING

13

Matki PLC, Churchward Road, Yate,
Bristol BS37 5PL

EN 14428:2008+A1