

matki | S H O W E R I N G

ELIXIR BASIN FILLER - BLADE DESIGN EXD20/185

INSTALLATION

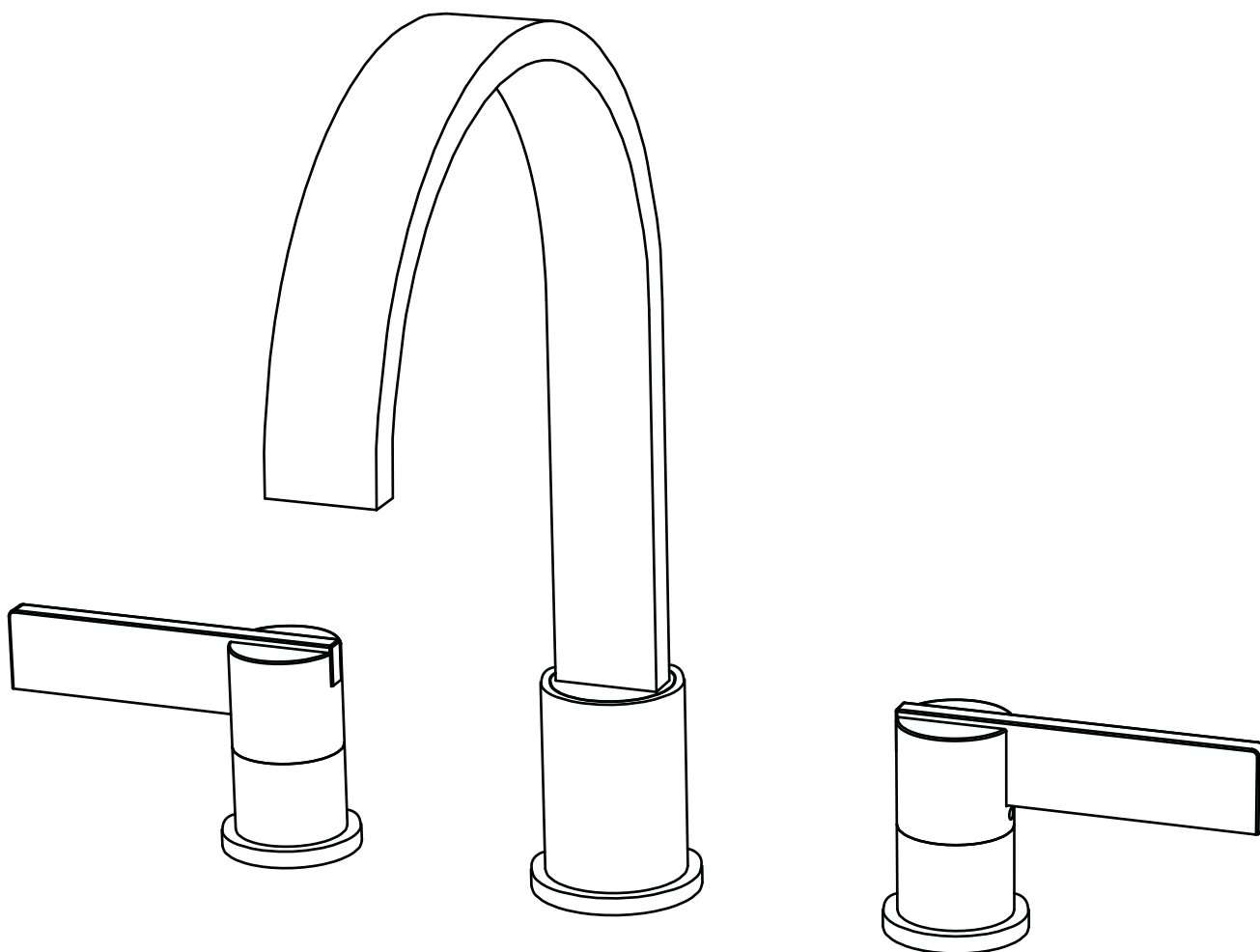

MATKI PLC, CHURCHWARD ROAD, YATE, BRISTOL, BS37 5PL
TELEPHONE:01454 322 888 FAX:01454 315 284 EMAIL:techsupport@matki.co.uk

STAGE 1

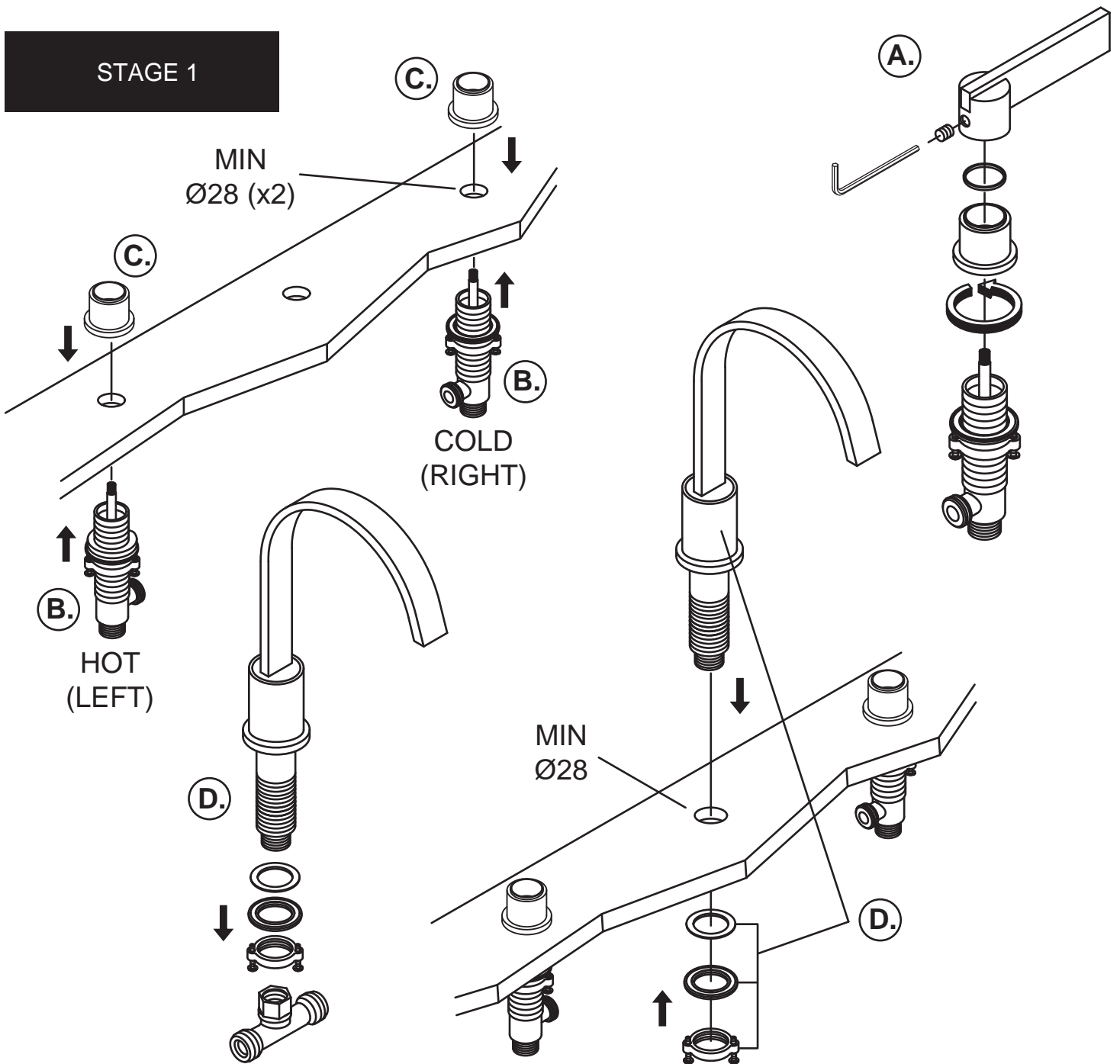

This stage describes the assembly of the Tap Bodies & Spout.

A. The Tap controls and Spout are supplied assembled. Unscrew the Tap handle lever to access the set screw, loosen the set screw with the Allen key supplied and remove the handles then unscrew the tap handle base so the brass body can be fitted underneath the Basin/Bath. Place the tap handles white washer and handle levers in a safe place for final fitting.

B. The tap handle bodies are configured for Hot and Cold. Please fit the **Hot** brass body on the **Left** and the **Cold** brass body on the **Right**. The **Hot** and **Cold** bodies are marked with a **Red** and **Blue** label which also shows the direction of inlet flow.

C. Screw the brass bodies and tap bases together through the Basin/Bath holes. Tighten the brass ring, stainless steel disc and rubber seal to the underside of the Basin/Bath.

The brass ring can be fully tightened with the two pozi-drive screws on the brass ring. Do not refit the handles at this stage.

D. Unscrew the brass ring, stainless steel disc and rubber seal and T connector from the Spout Body then screw fit them back together through the central Basin/Bath hole. The brass ring can be fully tightened with the two pozi-drive screws on the brass ring.

STAGE 2

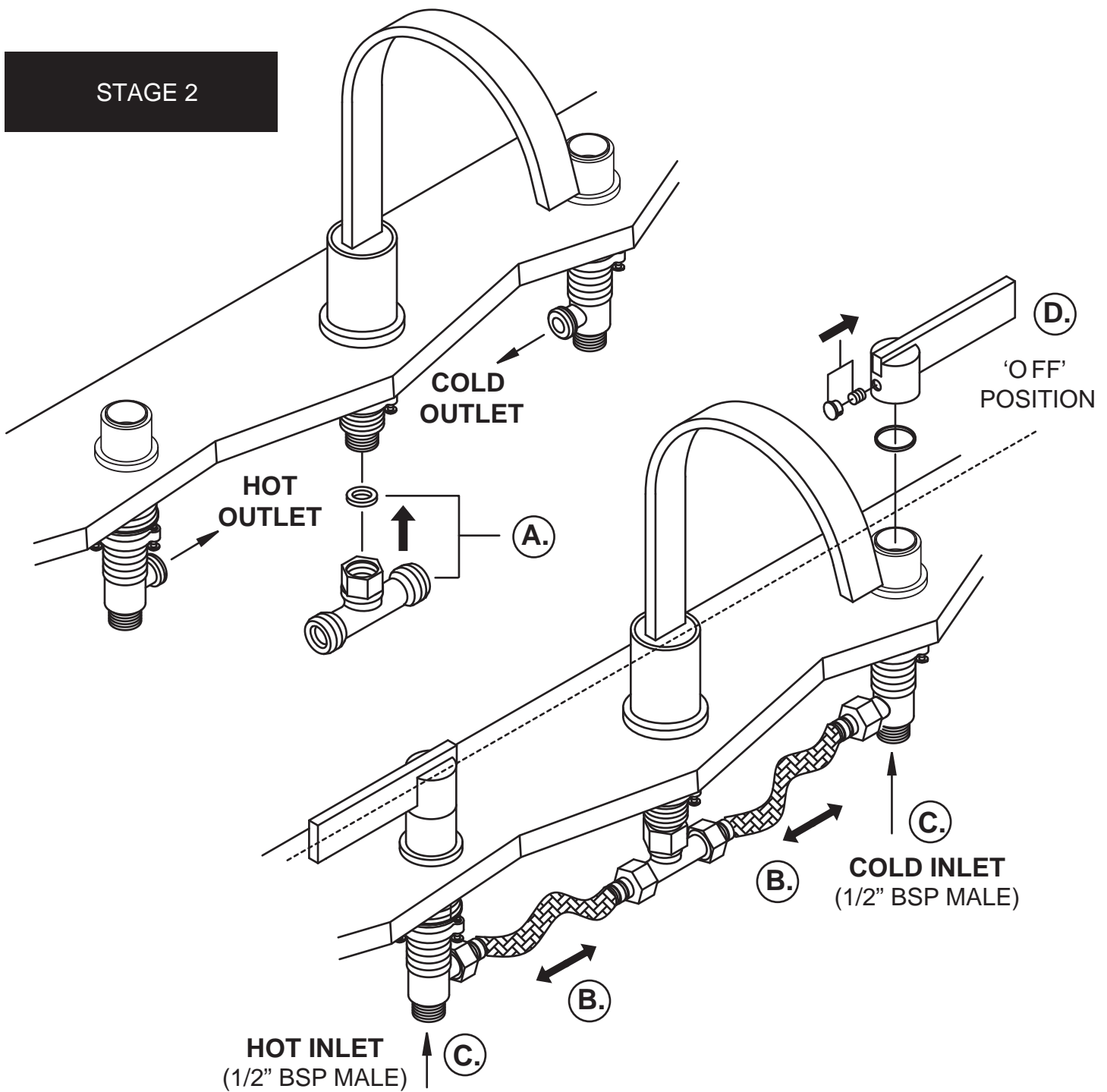

This stage describes connecting the Taps and Spout with the hot and cold water supplies.

Please fit isolation valves on the **Hot** and **Cold** inlet supplies as close as possible to the tap connections.

A. Tighten the T-Connector to the bottom of the Spout Body, please ensure the rubber sealing washer inside the nut is in place.

B. Connect the two 1/2" BSP braided hoses to the Spout T-Connector then to the horizontal outlets on the tap brass bodies and tighten.

C. Connect the Hot and Cold inlet supplies to the bottom of the tap brass bodies.

The Hot and Cold inlets are 1/2" BSP Male parallel threaded connections. Important, do not use tapered threaded adaptors when connecting to the Hot & Cold inlets. Threaded joint connections should be made with PTFE tape. Do not use Oil based non setting jointing compounds. Test the Hot and Cold connections for leakage by temporarily fitting the tap handles.

D. Finally secure the handles so that the levers are positioned as shown in the 'off' position.

Ensure that the white ring is assembled to the top of the tap body. Secure the handle with allen key and insert screw-hole cover.

DIMENSIONS

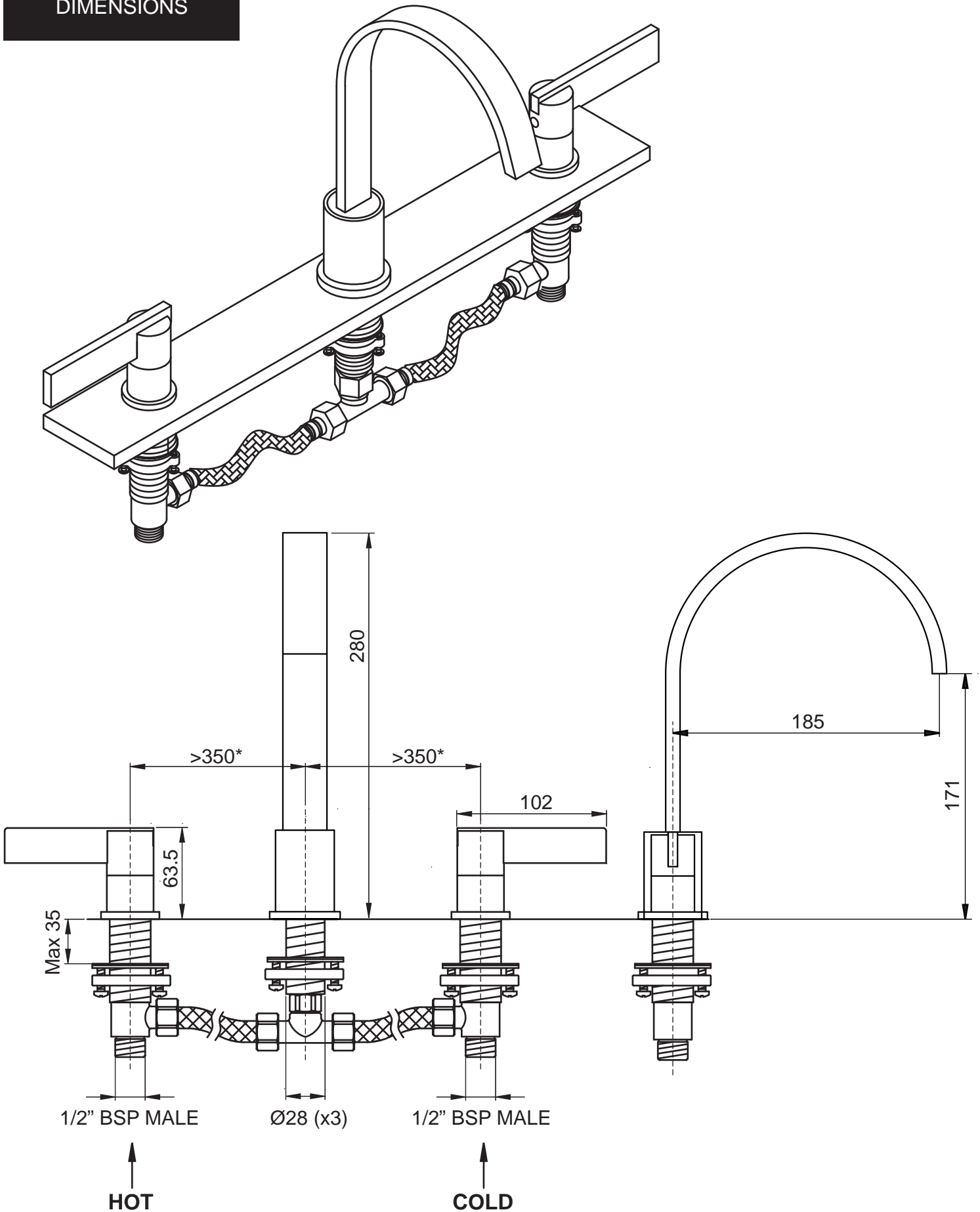

*Flexible hose enables variable mounting distance - up to 350mm.

**Depending on model.

Dimensions are approximate. All Dimensions are in mm.