

SPECIFICATION SHEET

COLLECTION: ELEMENTS

PRODUCT CODE: ELA-150S-C/P



DESCRIPTION:

sink mixer
single lever
deck mounted
spout can swivel or be fixed
without pop-up waste
with water flow straightener
with water flow aerator
ceramic cartridge CAR-K35B
2 x 1/2" nut x 300mm flexipipe connections
deck mount drill hole diameter 32mm
minimum operating pressure 1.0 bar MP

FINISH:

Chrome

FLOW REGULATOR:

FR-100/5-PLA

MINIMUM OPERATING PRESSURE:

1.0 bar MP

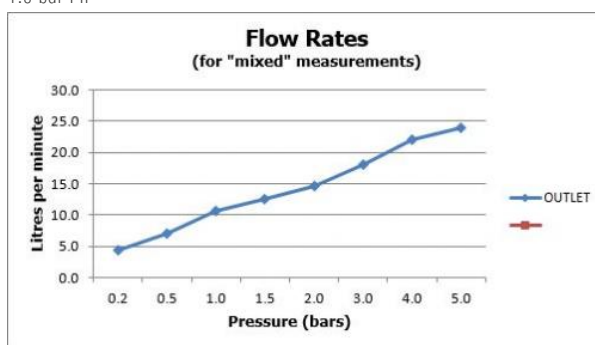

tel: 01934 744466
email: sales@vado.com
www.vado.com

where inspiration flows
taps | showering | accessories



TECHNICAL DRAWING

COLLECTION: ELEMENTS

PRODUCT CODE: ELA-150S-C/P

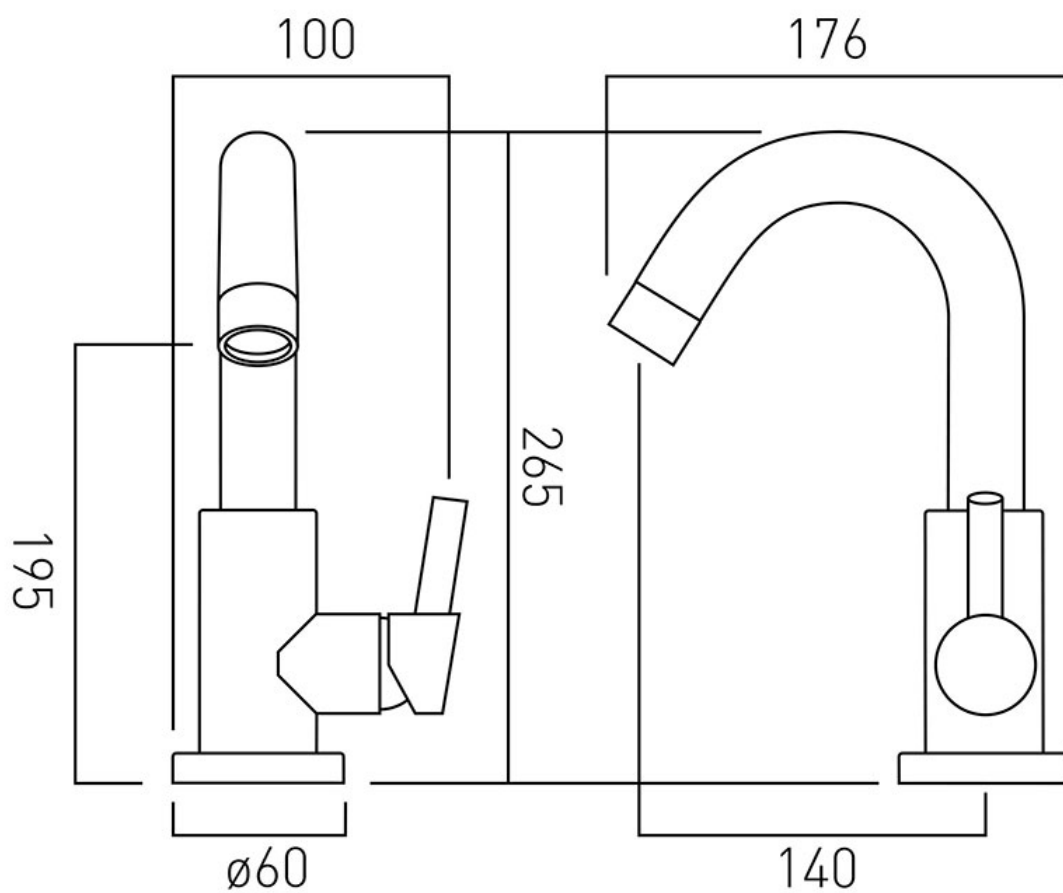

tel: 01934 744466
email: sales@vado.com
www.vado.com

where inspiration flows
taps | showering | accessories

