

Concept Cube 50cm Short Proj S/C Washbasin, 1 LH Taphole

ILLUSTRATED

- E7798** Concept Cube 50cm short projection semi countertop washbasin, glazed back edge, 1 left hand taphole with overflow
- E0157** Wall fixing set
- B8062** Active single lever one hole basin mixer with pop-up waste.
- S8920** Trap 1¼" plastic resealing bottle, 75mm seal, multi-purpose outlet

ILLUSTRATED PRODUCT DETAILS

Sizes

E7798 w:360 x d:500

Weights

E7798 12.73 KG

E0157 0.16 KG

B8062 2.42 KG

S8920 2.00 KG

Materials

E7798 Fine Fireclay

E0157 Metal

B8062 Chrome Plated Brass

S8920 Plastic

Finishes

E7798  White (01)

E0157  Neutral / No Finish (67)

B8062  Chrome (AA)

S8920  Neutral / No Finish (67)

Capacity

E7798 4 litres

Flow rates

B8062 5 Litres per minute @ 3 bar pressure

Designer

Robin Levien, RDI

Standards

Washbasin to BS EN 14688 & BS EN 31

Special Notes

Washbasin fixed to countertop with securing clips provided. Joint sealed with waterproof sealant (not supplied). Basin designed to work with short projection furniture to a minimum of 210mm projection allowing 10mm gap at rear to tile down onto worktop.

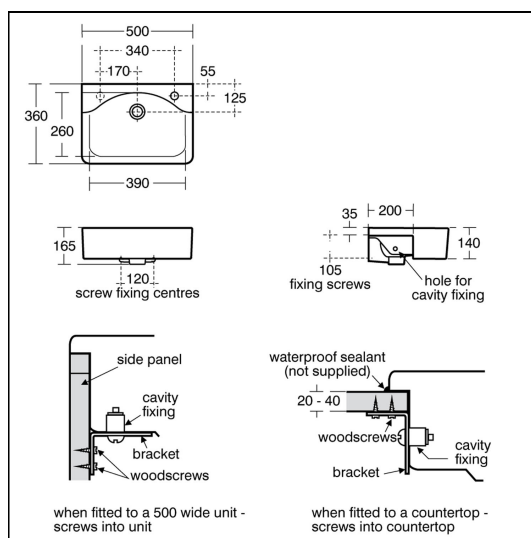

FEATURES

