

WASHINGTON TAPS
Basin Mixer | Standard | No Waste

RAK
CERAMICS

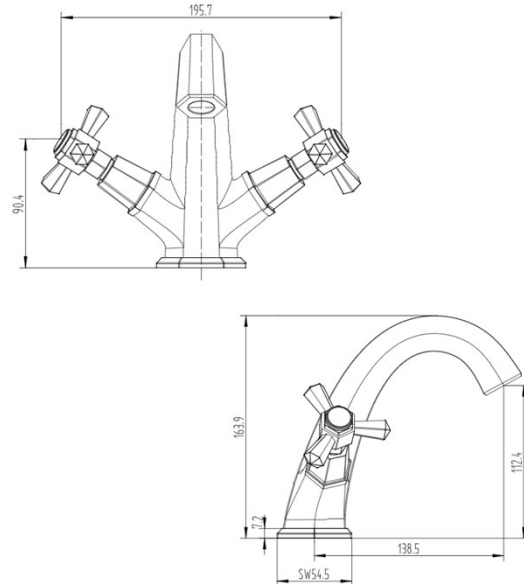

Dimensions: 195.7w x 138.5d x 163.9h mm

Colour: CHROME

Code: RAKWTN3001

Pressures: 0.5 BAR – 6.0 BAR

Warranty: 15 YEARS

Weight: 2.95 KG

Dimensions: All Dimensions in mm tolerance $\pm 5\%$ for below 200mm and $\pm 3\%$ for above 200mm.
Note: Due to a continuing development programme to improve design and performance the manufacturer reserves all rights to vary specifications without prior information.
Please note accessories are for photographic use only.