

Sales Code: LON217

Description: 1050 Mirror Cabinet

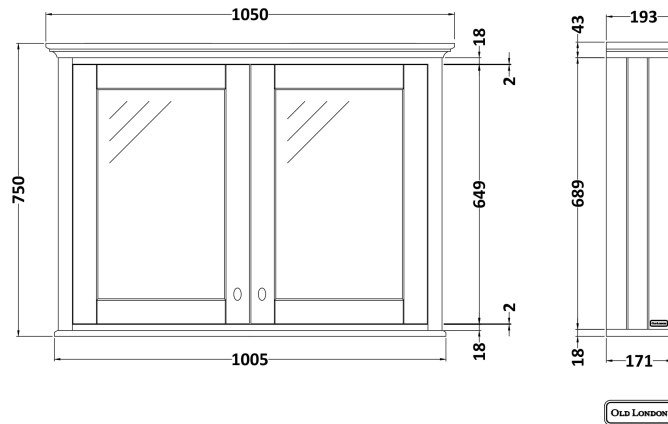
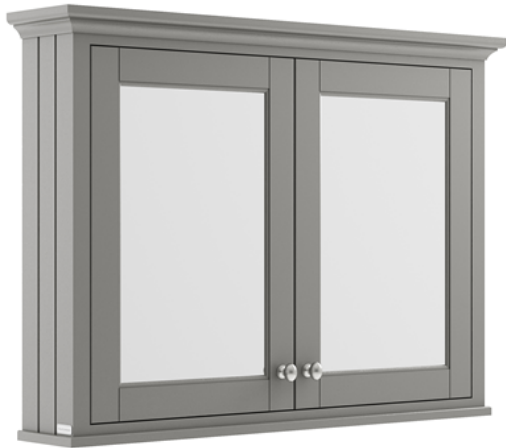

### Product Dimensions

Height (mm):	750
Width (mm):	1050
Depth (mm):	198
Nett Weight (kg):	37.5

### Packaging Dimensions

Height (mm):	777
Width (mm):	1080
Depth (mm):	223
Gross Weight (kg):	38

### Packaging Data

Box Colour:	Brown Cardboard Box
Box Qty:	1
Label Size:	150 x 100
Label Colour:	White Label
Label Qty:	2

### Outer Box Dimensions (If Applicable)

Height (mm):	
Width (mm):	
Depth (mm):	
Gross Weight (kg):	
Barcode:	5056211818175

### Product Details

Country of Origin:	United Kingdom
Fitting Instruction:	Yes
Certification:	FSC: Yes CE:
Colour:	Storm Grey
Construction Method:	Cam & Wood Dowel
Construction Type:	Rigid
Cabinet Finish:	Mdf Vinyl Textured Woodgrain
Fascia Finish:	Mdf Vinyl Textured Woodgrain
Cabinet Thickness (mm):	18
Fascia Thickness (mm):	18
Drawer Included:	Not Applicable
Drawer Type:	Not Applicable
No of Shelves:	1
Hinge Type:	95 Degree Inset Clip-On S/C
Hinge Included:	Yes
Adjustable Legs:	Not Applicable
Fixings Included:	Yes
Handle Style:	Traditional
Handle Included:	Yes
Waste Shroud:	Not Applicable
Handle Type:	Knob