

Sensorflow 21 Tubular 23cm Panel Mounted Spout & Separate Sensor-Battery

ILLUSTRATED

A4182 Sensorflow 21 tubular panel mounted 230mm projection spout anti splash or aerated outlet remote panel sensor, copper tube inlets, battery

ILLUSTRATED PRODUCT DETAILS

Weights

A4182 3.20 KG

Finishes

A4182  Chrome (AA)

Materials

A4182 Chrome Plated Brass

Flow rates

A4182 4.7 Litres per minute @ 3 bar pressure

FINISH OPTIONS



Special Notes

Designed to be supplied with pre-mixed water consideration should be given to safe hot water delivery and the use of an appropriate temperature reduction device see A5900. The proximity sensor should be positioned to work in the normal handwashing position. All spouts supplied complete with individual solenoid valve, copper tube inlet and combined servicing valve and filter. Spouts with integral sensors detect hands within the sensing range and the solenoid valve is opened. Automatically shuts off if sensor is obstructed for a maximum of 55 seconds. A stand alone battery powered unit

Flow rates, regulated to 5 Litres per minute or optional flow straightener outlet 2.8 Litres per minute @ 0.1 bar .

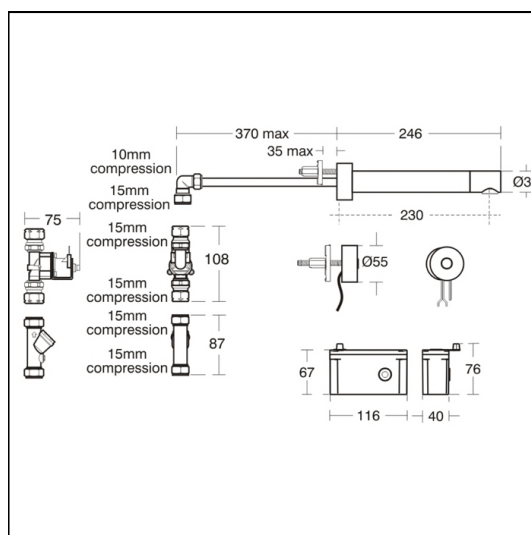
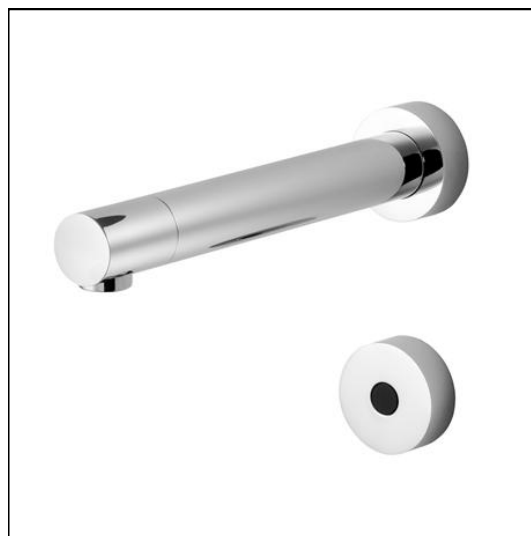

FEATURES

