

Sensorflow 21 Panel Mounted Cast Spout, Integral Sensor, Link

ILLUSTRATED

A4179 Sensorflow 21 panel mounted 15cm cast spout integral sensor, flexible inlet tail, solenoid valve, combined servicing valve and filter sensor and solenoid cables, copper tube inlets, link

ILLUSTRATED PRODUCT DETAILS

Weights

A4179 2.25 KG

Finishes

A4179  Chrome (AA)

Materials

A4179 Chrome Plated Brass

Flow rates

A4179 4.7 Litres per minute @ 3 bar pressure

FINISH OPTIONS



Special Notes

All spouts supplied complete with individual solenoid valve, copper tube inlet and combined servicing valve and filter. Spouts with integral sensors detect hands within the sensing range and the solenoid valve is opened. Factory set to remain open for 1 second after removal of hands and automatically shuts off if sensor is obstructed for a maximum of 50 seconds. Mains powered transformer - do not connect to an interruptible power supply with option to link up to 5 link units per main unit or stand alone battery powered units.

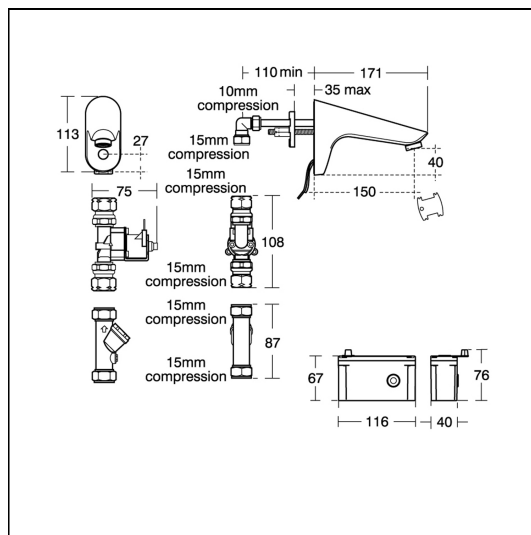

FEATURES

