

Edition 11

51120XX0100 Bath tub mixer DN 15

**PRODUCT**



**DRAWING**

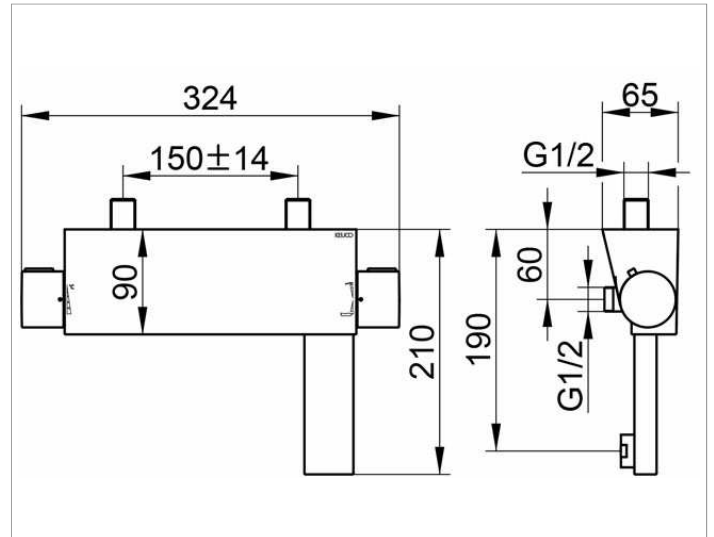

**PRODUCT ATTRIBUTES**

exposed  
 ceramic stop valve and diverter,  
 cartridge mixer with ceramic sealing gaskets,  
 shower outlet connection DN 15  
 (restricted flow rate 12 l/min),  
 with backflow preventer,  
 gauge 150 +/- 14 mm,  
 suitable for combination boilers,  
 aerator M 28x1,  
 flow rate approx. 20 l/min.

**SURFACE**

02, 04, 12