

Plan
14963170002 Spare paper holder

PRODUCT

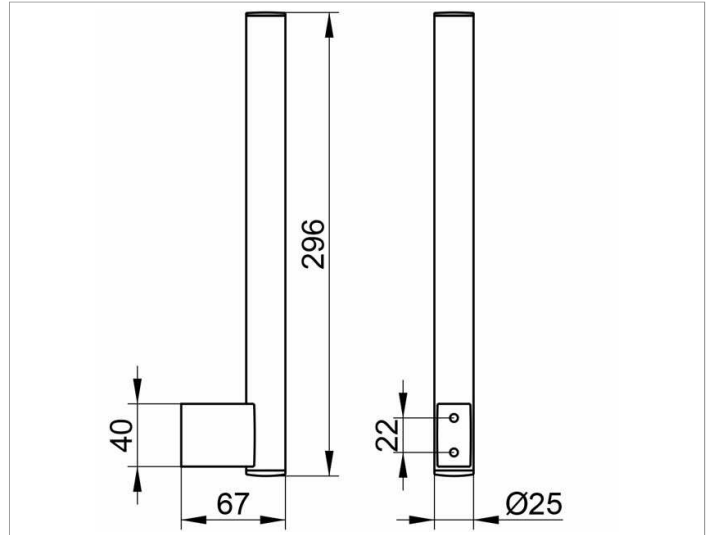

DRAWING



PRODUCT ATTRIBUTES

vertical version,
 capacity 2 rolls, for 100/120 mm wide paper rolls

SURFACE

aluminium silver anodized (E6 EV1)/chrome-plated

SPECIFICATIONS

KEUCO PLAN multiple spare paper holder, 14963170002
 Aluminium silver anodized (E6 EV1)/chrome-plated
 multiple spare paper holder for 2 WC paper rolls,
 roll width 100/120 mm, aesthetic, function design,
 for vertical wall mounting, with rectangular wall fixing,
 pipe diameter 25 mm, easy to clean,
 horizontal depth 66 mm, available pipe length 251 mm, total height 297
 mm,
 the multiple spare paper holder is fitted concealed,
 delivery includes anti-corrosion fixing