

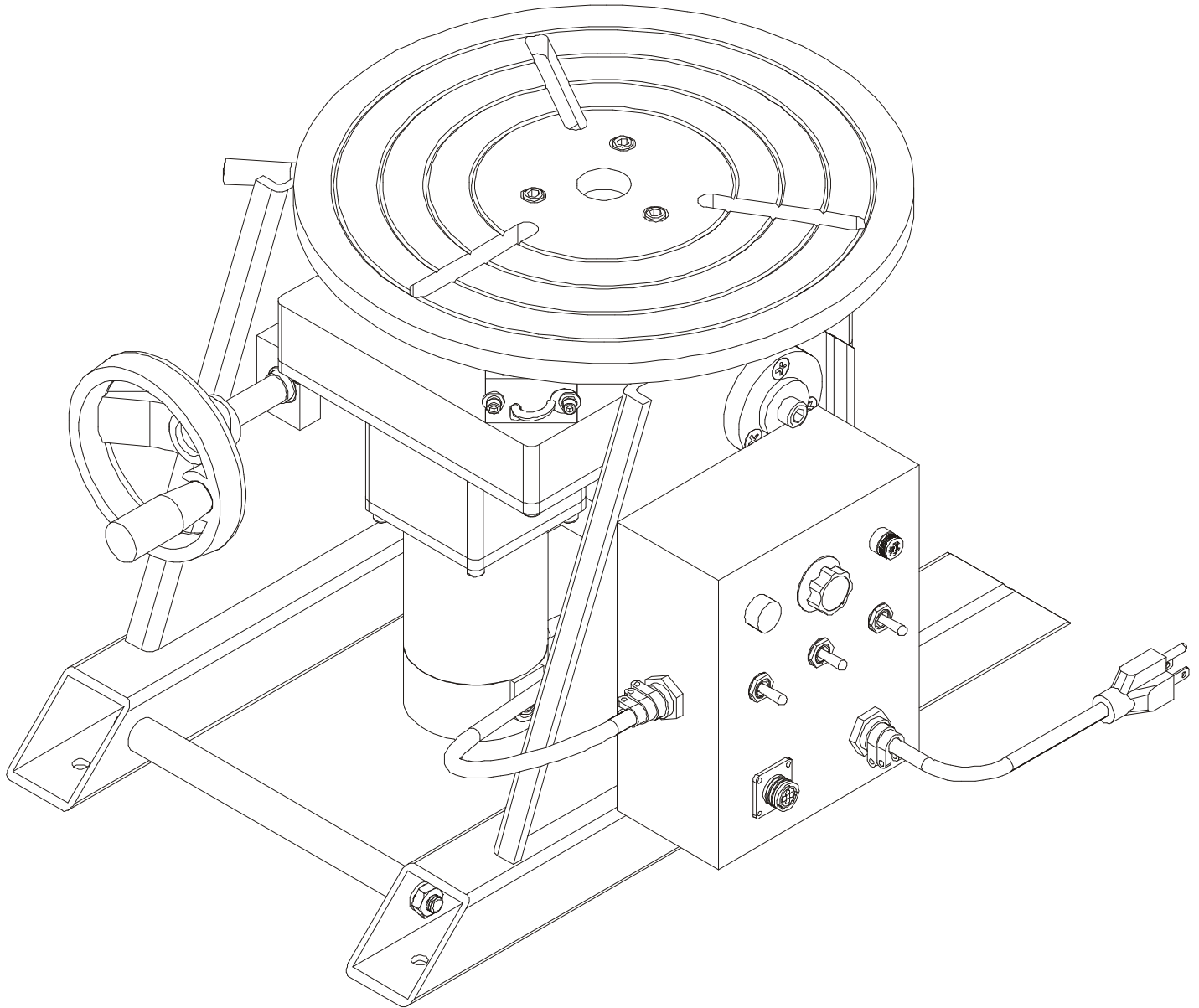

PROFAV[®]

WELDING POSITIONER



MODEL NO: WP-250

WARNINGS, SAFEGUARDS & OPERATING INSTRUCTIONS



Warnings and Safeguards for Welding and Cutting Operations



IMPORTANT - Protect yourself and others! Remember that safety depends on you. The operator, supervisor, and helper must read and understand all warning and safety information provided in these instructions. **Serious injury or death** could result if welding equipment is not properly installed, used and maintained. Training and proper supervision are most important for a safe work place. Installation, operation, repair work, and maintenance must be performed by qualified personnel. Retain these instructions for future use.



ELECTRICAL SHOCK CAN CAUSE INJURY OR DEATH

Electrical equipment must be installed and maintained in accordance with the National Electrical Code, NFPA 70, and all local codes. Maintain Mig-Guns, Electrode Holders, Tig Torches, Plasma Torches, Work Clamp, Welding Cable, and Welding Machines in good, safe operating condition. Replace worn or damaged insulation. Do not try to repair or service equipment while the power is still on. Do not service or repair equipment unless you are trained and qualified to do so. The Electrode and Work (or Ground) circuits are electrically "HOT" when equipment power is on. At no time should you touch the Electrode and Electrical Ground at the same time with bare skin or wet clothing while the power is on. Insulate yourself from work and ground using dry insulation. When welding in damp locations make certain the insulation is large enough to cover your full area of physical contact with work and ground. Ground the work (metal to be welded) to a good electrical earth ground. Keep gas cylinders, chains, wire ropes, hoists, cranes, and elevators away from any part of the electrical path. Always be sure the work cable makes a good electrical connection with the metal being welded. Occasionally check all ground connections to determine if they are mechanically strong and electrically adequate for the current required. The ground connection should be as close as possible to the area being welded. Never touch electrically "HOT" parts of electrode holders connected to two welding power sources at the same time. The voltage between the two can be the total of the open circuit voltage of both power sources. When the welding or cutting process requires values of open circuit voltages in alternating current machines higher than 80 volts, and direct current machines higher than 100 volts, adequate insulation or other means must be provided to prevent the operator from making accidental contact with the high voltage. The use of reliable automatic controls for reducing no load voltage is recommended to reduce shock hazard. When not welding for any substantial period of time, make certain that no part of the electrode circuit will accidentally make contact with the work or ground. Never immerse Mig-Guns, Electrode Holders, Tig Torches, Plasma Torches, or Electrodes in water for cooling.

REFERENCES: See Safety and Operating References A,F,H, and I.



SMOKE, FUMES, AND GASES CAN BE DANGEROUS TO YOUR HEALTH

Keep smoke, fumes, and gases from your breathing zone and the general area. Smoke, fumes, and gases from the welding or cutting process are of various types and strengths, depending on the kind of base metal being welded on. To ensure your safety, do not breathe these fumes or gases. Ventilation must be adequate to remove smoke, fumes, and gases during the welding procedure to protect operators and others in the immediate area. Do not weld in locations where chlorinated hydrocarbon vapors are coming from degreasing, cleaning, or spraying operations. Vapors of chlorinated solvents can form the toxic gas "phosgene" when exposed to ultraviolet radiation from an electric arc. All solvents, degreasers, and potential sources of these vapors must be removed from the welding area. Shielding gases used for arc welding can displace air and cause injury or death. Fumes produced by welding or cutting, especially in confined areas, can cause discomfort and physical harm if inhaled over an extended period of time.

Always provide adequate ventilation in the welding and cutting area to insure breathing air is safe. Use air-supplied respirators if ventilation is not adequate to remove all fumes and gases. **Never Ventilate with Oxygen**, because oxygen supports and vigorously accelerates fire.

REFERENCES: See Safety and Operating References A,B,C,H, and I.



HOT PARTS

Hot parts can cause serious burns. The area at and near the work being welded should be handled with proper gloves. Proper clothing should be worn to prevent spatter or chipped slag from causing burns. Never pick up welded material until it has properly cooled.

REFERENCES: See Safety and Operating References A, B, H, & I.



MOVING PARTS MAY CAUSE INJURY

Have only qualified people remove guards or covers for performing maintenance and troubleshooting. Moving parts such as cooling fans can maim fingers or hands and catch loose clothing. Keep tools, hands, hair and clothing away from moving parts. Be sure to reinstall all panels and guards before operating equipment.



FALLING EQUIPMENT

Lift only the unit to be moved without any running gear, accessories or gas cylinders that may be attached to it. Use equipment of a proper size to lift and move the unit. Falling equipment can cause personal injury and equipment damage.

REFERENCES: See Safety and Operating References A, B, H, & I.

Safety and Operating References

- A) ANSI Z49.1, "Safety in Welding and Cutting"
- B) ANSI Z87.1, "Practice for Occupational and Educational Eye and Face Protection"
- C) ANSI Z88.2, "Standard Practice for Respiratory Protection"
ANSI: American National Standard Institute, 1430 Broadway, New York, NY 10018
- D) ANSI F4.1, "Recommended Safe Practices for Welding and Cutting Containers"
AWS: The American Welding Society, P.O. Box 351040, 550 NW Lejeune Rd., Miami, FL 33135
- E) NFPA 51B, "Fire Prevention in Cutting and Welding Processes"
- F) NFPA-70, "National Electrical Code"
NFPA: National Fire Protection Association, Batterymarch Park, Quincy, MA 02269
- G) CGA P-1, "Precautions for Safe Handling of Compressed Gases in Cylinders"
CGA: Compressed Gas Association, 1235 Jefferson Davis Hwy., Arlington, Va 22202
- H) Code of Federal Regulations (OSHA) 29 CFR 1910
US: U.S. Government Printing Office, Washington, DC 20402
- I) CSA Standard W117.2, "Safety in Welding, Cutting and Allied Processes"
CSA: Canadian Standards Association, 178 Rexdale Blvd., Rexdale, Ontario, Canada M9W 1R3



LIMITED WARRANTY: Subject to the terms and conditions hereof, **PROFAX**, Pearland, TX warrants its products to be free from defects in workmanship and material at the time of delivery by **PROFAX**.

PROFAX will honor warranty claims on products as a result of failure from a defect for a time period of 90 days from the date of sale to the original user. Upon return of the merchandise at the user's expense, **PROFAX** reserves the right to either repair or replace as necessary. This is the only warranty either expressed or implied covering this product.

Positioner Specifications:

Horizontal Weight Capacity, (Lbs.) Note: C/G of load not to be more than 4" from Center of Turntable.	440
Vertical Weight Capacity, (Lbs.) Note: C/G of load not to be more than 4" from Center of Turntable.	250
Motor, (Horsepower)	1/8
Power Requirement, (Volts/Amps)	115V @ 5 amps
Rotation Speed Range, (RPM)	0 - 5
Table Diameter, (in.)	13-3/4"
Tilting Angle	0 - 90°
Tilting Method	Manual
Table Grounding	Carbon Brush
Table Height @ Horizontal, (in.)	13-7/32"
Unit Length, (in.)	21"
Unit Width, (in.)	12-7/16"
Shipping Weight, (Lbs.)	113

Positioner Dimensional Drawings:

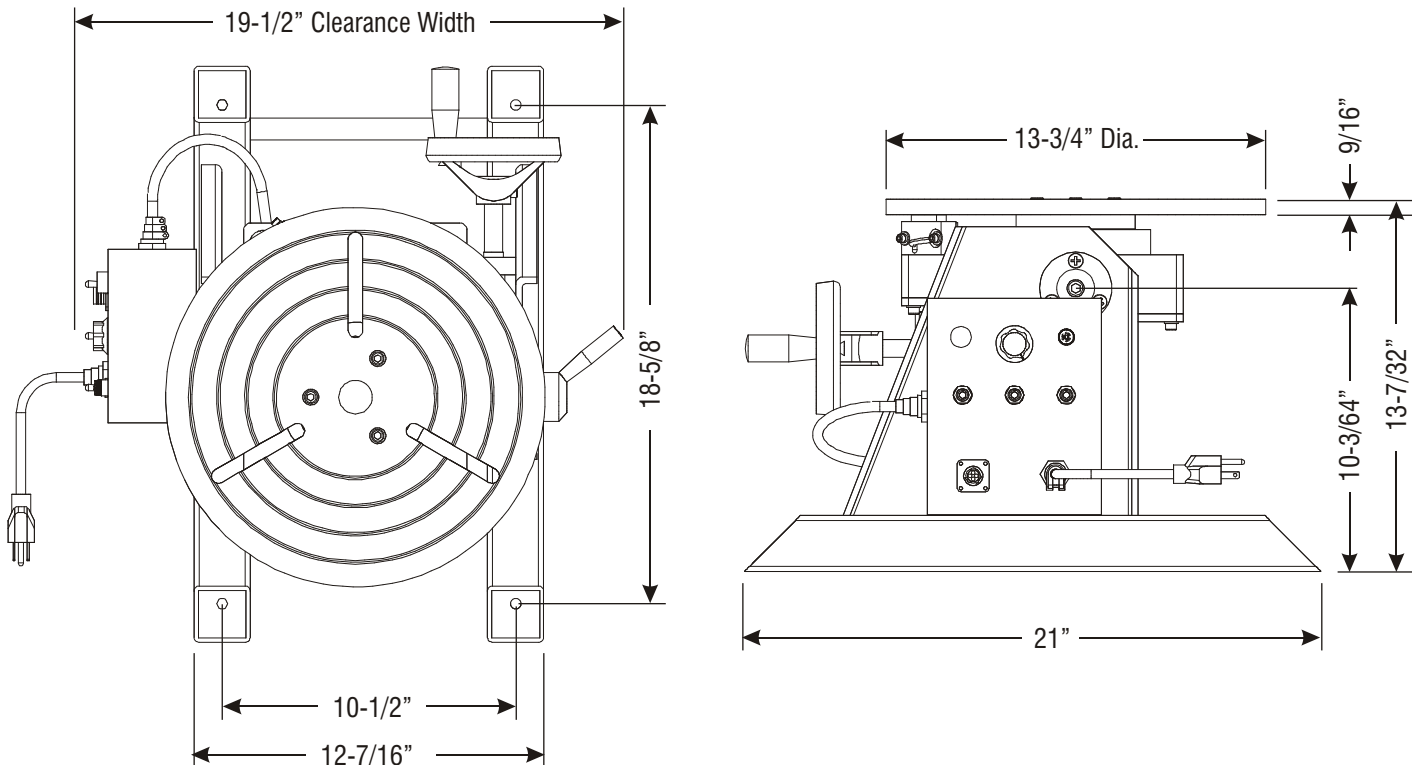

Figure No. 1 Dimensional Drawings



WP-250 General Operating Instructions



The **PROFAX** Welding Positioner is designed for light loads, with a maximum load of 250 lbs. when the table is in a vertical position and 440 lbs. when it is in the horizontal position.

Loading the Positioner

The positioner may be floor or bench mounted. When mounting the positioner on a bench it is advisable to secure it solidly to the bench to avoid any possibility of tipping over with a load. See figure 1 for mounting dimensions.

When loading the work piece onto the table it is important that the following guide lines are followed to avoid over turning the positioner and/or overloading the motor and gear train.

1. Determine the total weight of your work piece including all fixtures, chucks, brackets, etc.
Note: This must not exceed 250 lbs. with the table in the vertical position or 440 lbs. with the table in the horizontal position.
2. Locate the center of gravity of the work piece with any fixtures attached.
3. Mount the work piece to the turn table making sure that the center of gravity is within 4" of the center of the turn table as shown in figure No. 2.

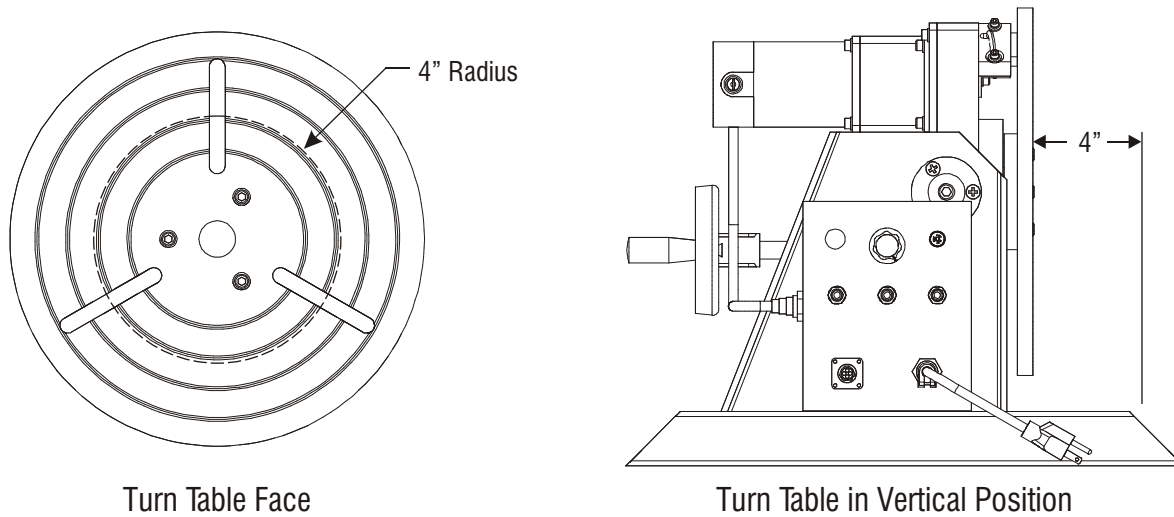

Figure No. 2

Warning! Use equipment of a proper size to lift and/or move the weldment onto the positioning table. Falling equipment can cause personal injury and/or equipment damage.

Welding Cable Ground (Work) Connection

The positioning table is grounded by means of a brush which contacts the underside of the table. See Figure 3. Connection to this is by means of a welding cable lug. Attach the welding cable lug to a properly sized welding cable and then attach the lug to the brush holder by means of the bolt provided. Tighten the bolt securely. The brush has a maximum allowable welding current of 200 amps. Do not attempt to run higher than 200 amps through the grounding brush. Welding currents greater than 200 amps should be grounded directly to the work piece by means of a proper ground clamp.

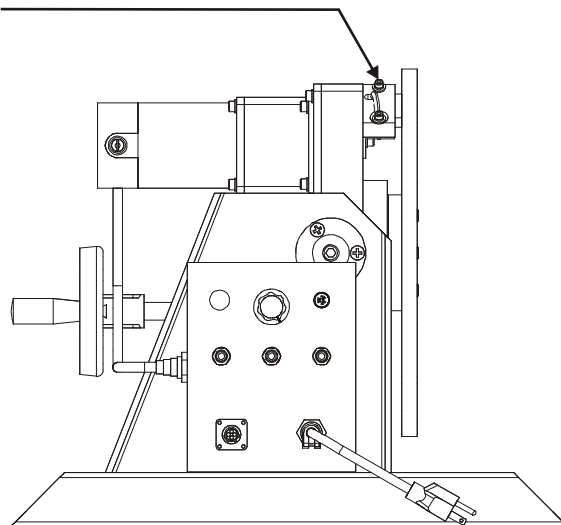
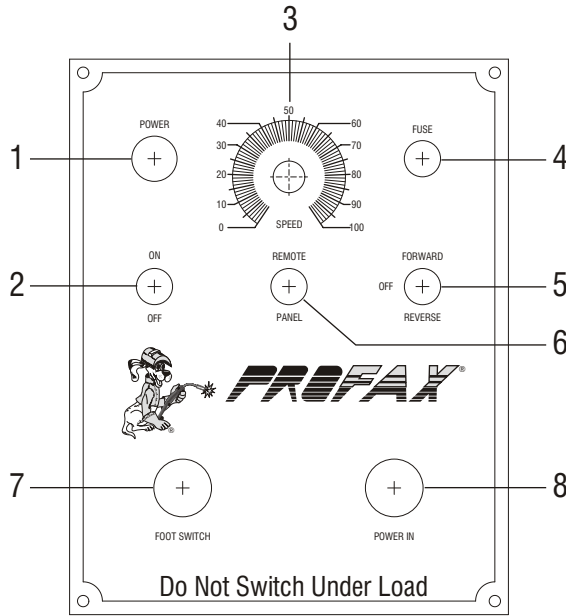

Figure No. 3



Control Panel & Wiring Diagram



1. **Pilot Light:** Lights up red to indicate power on.
2. **Power On-Off Switch**
3. **Speed Control:** Provides control of table rotation speed from 0%(0 RPM) to 100%(5 RPM).
4. **Fuse Holder:** Fuse 5 amp
5. **Forward/Off/Reverse Switch:** Controls table rotation. Forward (clockwise rotation) and Reverse (counterclockwise rotation).
6. **Remote/Panel Switch:** Remote = Start and stop are remotely controlled. Panel = Start and stop are operated from the control box.
7. **Remote Plug:** Plug-in for the foot switch to start and stop of the turn table rotation.
8. **Power in**

CAUTION! - Switching rotation direction before coming to a complete stop may damage motor and/or gear box voiding warranty.

Wiring Schematic

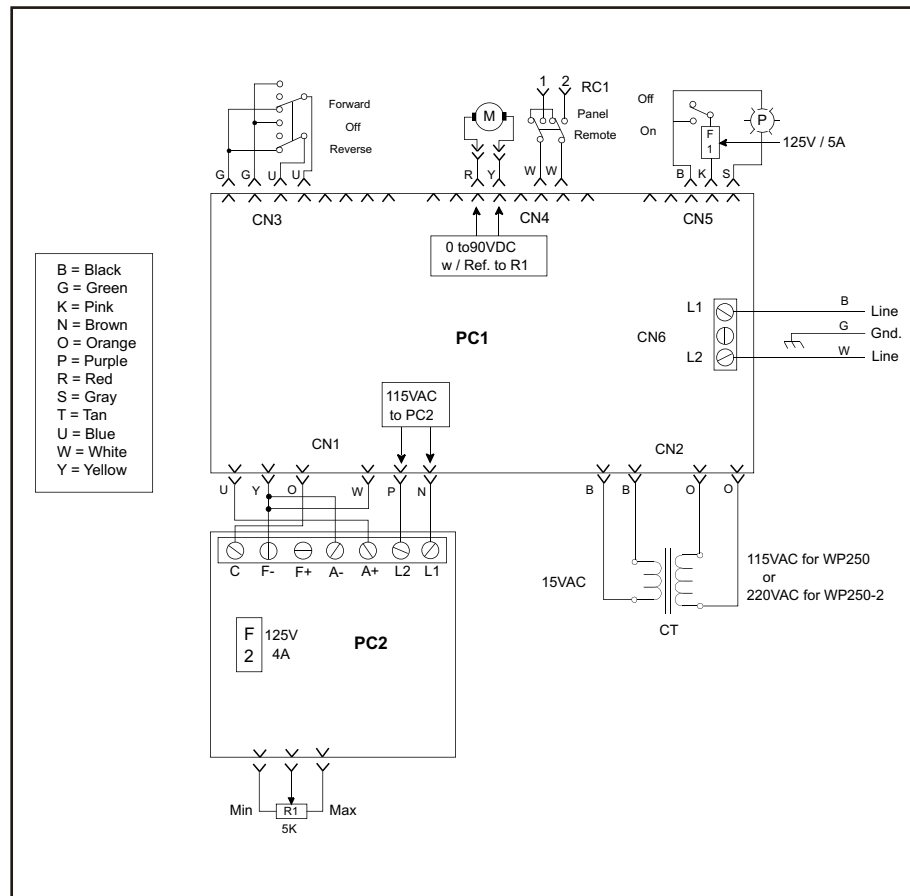

Service or repair of this unit must be done by qualified personnel only.

Warning! Before performing any maintenance on this control circuit disconnect the unit from any power supply.



WP-250 Parts List

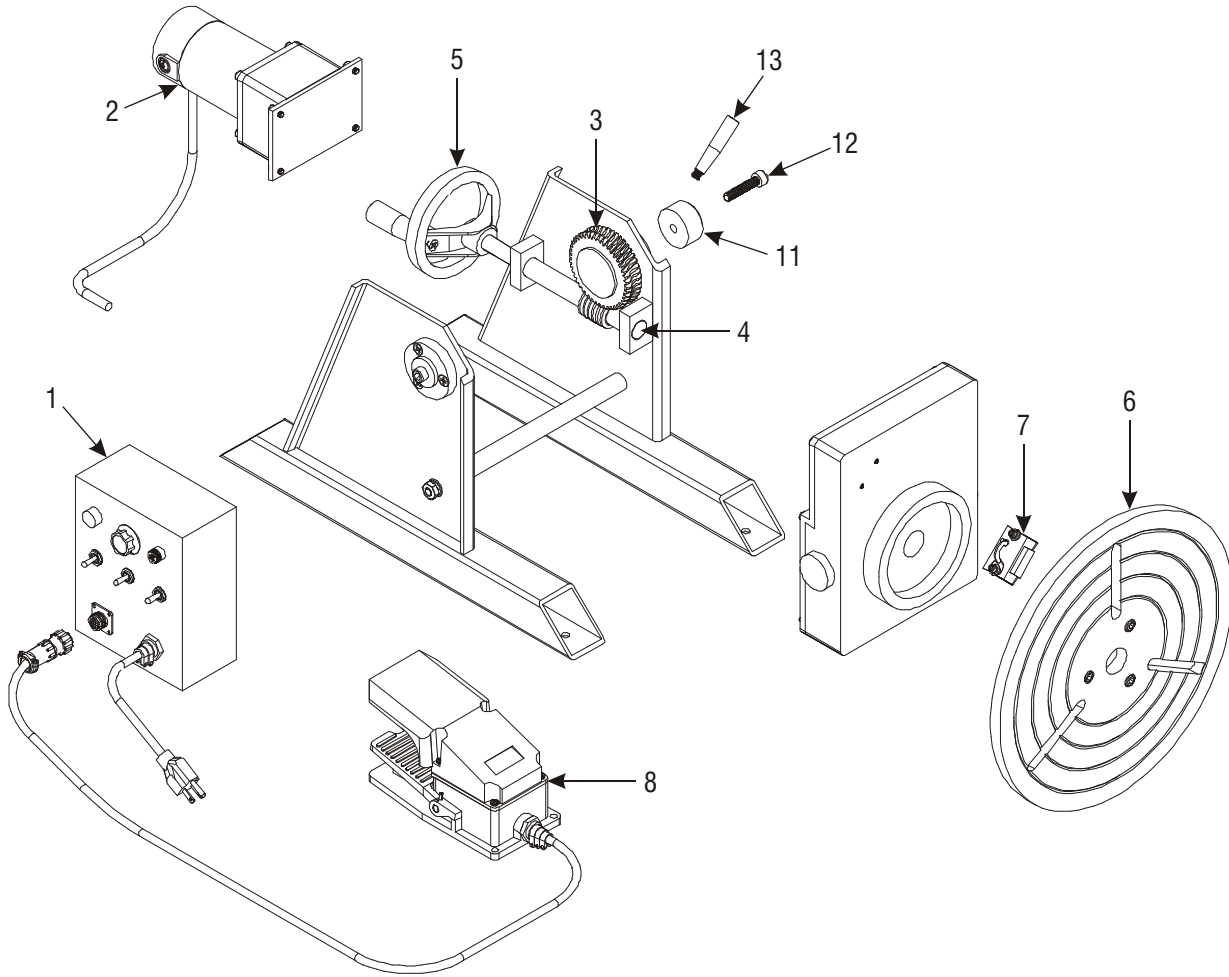

NO.	PROFAX	DESCRIPTION	NO.	PROFAX	DESCRIPTION
1.	PX9912	Control Box Complete	8.	PXCFS-302	Foot Control Switch
2.	PX9913	Motor	9.	PX9924	Fuse, Power 5A (Not Shown)
3.	PX9914	Worm Gear	10.	PX9925	Fuse, PC2 4A (Not Shown)
4.	PX9915	Shaft, Gear, and Bushing Assembly	11.	PX9926	Tilt Lock
5.	PX9916	Hand Wheel	12.	PX9927	Tilt Lock Securing Bolt
6.	PX9917	Turn Table	13.	PX9928	Tilt Lock Handle
7.	PX9918	Grounding Brush & Holder			

TROUBLE SHOOTING

PROBLEM	POSSIBLE CAUSE	SOLUTION
Indicator Light Fails to light	<ol style="list-style-type: none"> No power Fuse blown Faulty indicator light Faulty power switch 	<ol style="list-style-type: none"> Check power supply for 115VAC 50/60Hz. Check and replace fuse. Check and replace indicator light. Check and replace power switch.
Fuse blown	<ol style="list-style-type: none"> Faulty PC board Faulty motor Faulty or bad transformer 	<ol style="list-style-type: none"> Check and replace control box (see item 1 below). Check and replace motor. Check and replace control box (see item 1 below).
Table fails to turn	<ol style="list-style-type: none"> Faulty PC board or control box Faulty motor Faulty forward/off/reverse switch 	<ol style="list-style-type: none"> Voltage to motor should vary from 0 to 90VDC in relation to the speed control. If output is erratic or non-existing replace control box. Check and replace motor. Check to see if switch is in correct position. Must be in either forward or reverse position to run. Test switch continuity.
Table will not tilt	<ol style="list-style-type: none"> Tilt lock engaged 	<ol style="list-style-type: none"> Release tilt lock.



Daily Maintenance



*NOTE: INSPECT & REPAIR BEFORE OPERATION.

- Inspect table ground for proper ground tension against table. (Positioners)
- Check oil level in gear cases & fill if necessary. (WP-500/WP-1000/WP-2000)
- Inspect foot pedal and/or pendant for proper operation.
- Test limit switches if applicable.
- Test operation of power switch and/or emergency stop button.
- Check for any broken wires, loose connections, worn parts or damages before operation.
- Apply grease to all gears and grease fittings. (Weekly)

