



QF Innovations

QFIII-SP Hybrid Pipe Clamp User Guide

Pipe & Boiler Tube Hybrid Clamp
1 – 10in Pipe & Tube



CAUTION



QFInnovations Inc. offers an easy-to-use line of Hybrid, size adjustable pipe clamps for the purpose of aligning and positioning small diameter pipe and tube joints. Always ensure the use of proper and required PPE for personal use when using the QFIII-SP clamp, as well as the provided anchor for tool fall protection.

QF values your business and we are committed to customer satisfaction and loyalty. We strive to provide innovative pipe fitting solutions and technology and look forward to providing our customers with innovative pipe fitting solutions for years to come. The QFIII-SP pipe clamp is backed by our extensive warranty and QF is happy to provide direct customer service and technical information at the contact numbers provided.

The QFIII-SP User Guide has been written and assembled to provide you with the best use and practices information for safe and efficient use of the unit. As we are committed to customer service, we invite you to contact us directly with any additional questions, technical needs or feedback.



Model

QFIII-SP Hybrid

**Small Diameter Pipe / Boiler Tube
Pipe Clamp**

Parts & Component Description

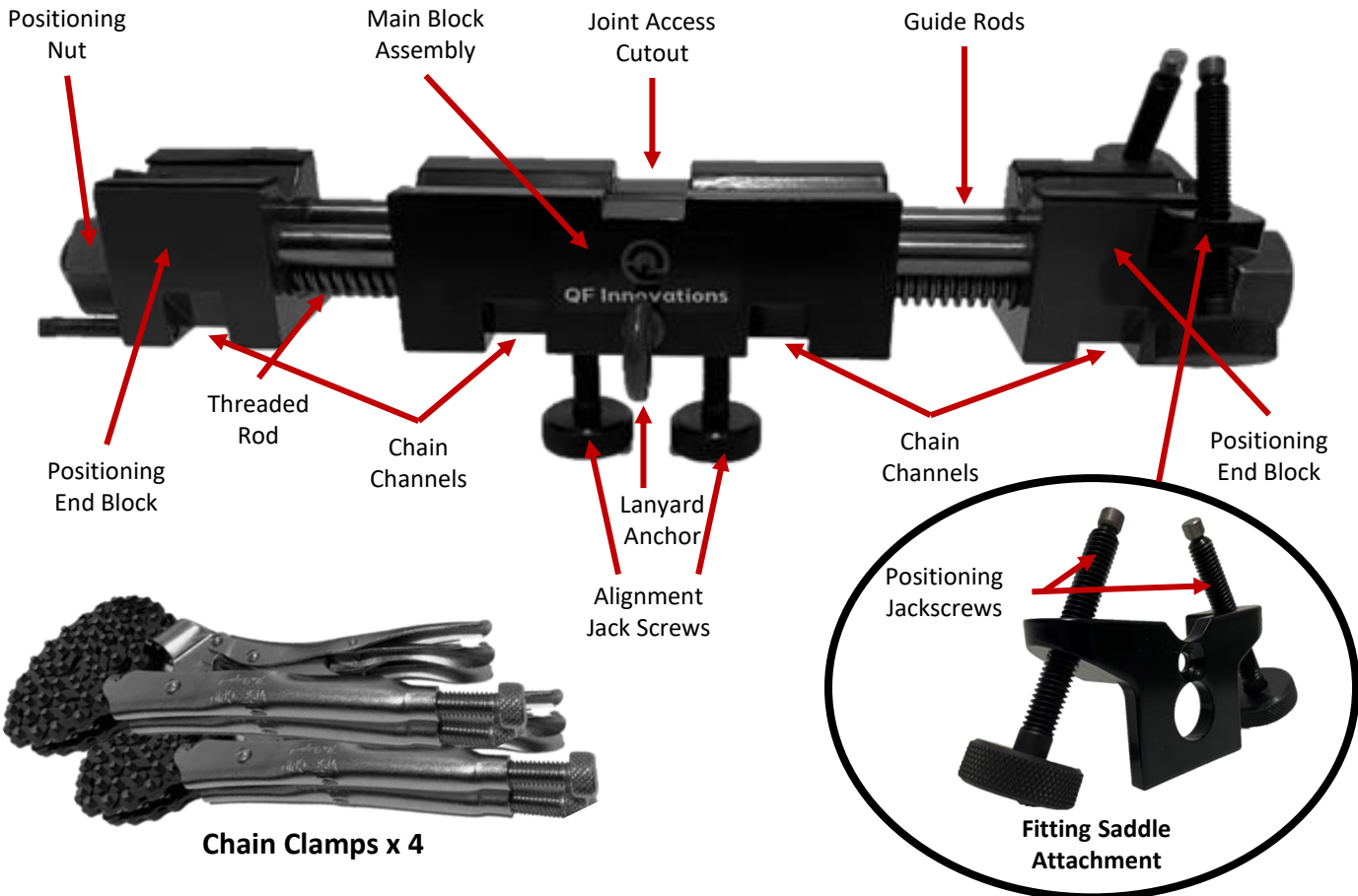

Warranty

All Products manufactured by or for QF Innovations Ltd are guaranteed against defects, faulty workmanship and or materials, for a period of twelve months from the date of purchase. This warranty is limited to the repair or replacement of any parts found to be defective and no other liability will be assumed.

QFIII-SP

Installation & Use

QFInnovations recommends the use of tool fall protection at all times.

1. Back off positioning adjustment nuts on the QFIII end blocks.
2. Install and attach the supplied tool lanyard anchor on the QFIII-SP main block and securely attach a tool lanyard or the required tool fall protection gear. Tie off
3. Place clamp on pipe, positioning the center of the main block over the pipe joint.
4. Clamp end blocks in place with the provided chain clamps, ensuring the chains are in the block channels and clamped tight to accommodate positioning / gap adjustment. (Multiple chains can also be used on each end block for larger loads)
5. Positioning / gap adjustment is recommended prior to clamping the main block if possible, allowing for easy lateral pipe movement. (Each end block provides up to 2in of stroke by turning adjustment nuts by hand or with a wrench when required).
6. Once the pipe gap is adjusted, jack screws are provided in the main block, for any alignment needs. The main block also contains chain channels (locations 3 & 4) for additional chains to further aid with alignment if needed.

Chain clamp placement and sequence

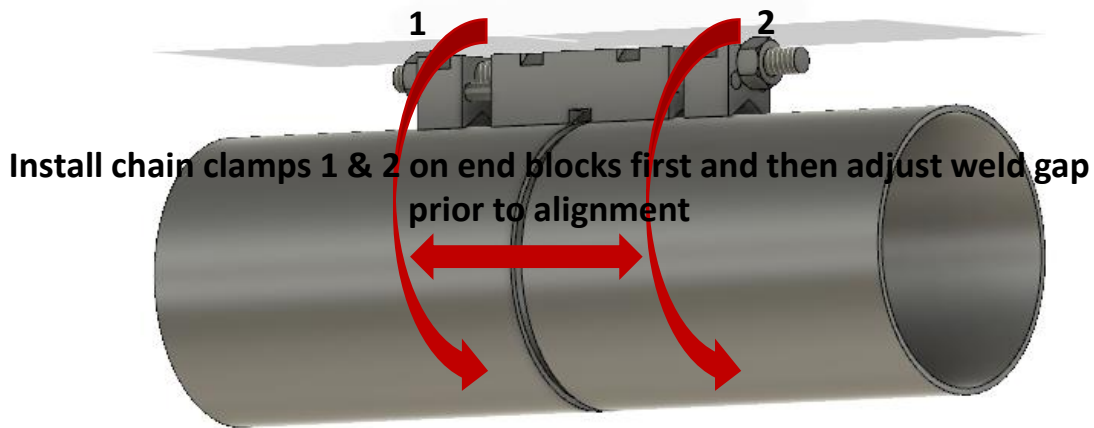

Important!

Gap adjustment / Lateral Pipe Movement

When clamping End Blocks (1 & 2 first) it is important to apply enough clamping force to accommodate the lateral force required for positioning / gap adjustment.

ie. Larger loads equal greater clamping forces required with chain clamps.

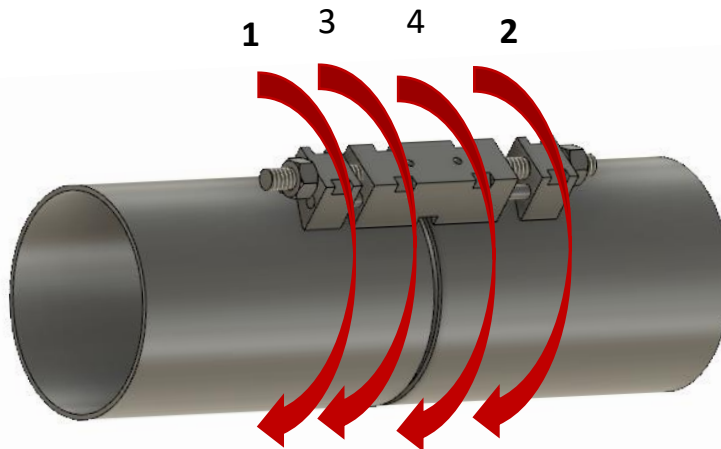

QFIII-SP Fitting Saddle



A bolt on saddle attachment (easily installed and removed), that allows for the quick adaptation of the QFIII clamp to quickly accommodate various fittings from 1 to 10in. The 2 jack screws provide the ability to quickly adjust and level various fittings and sizes.

Elbows

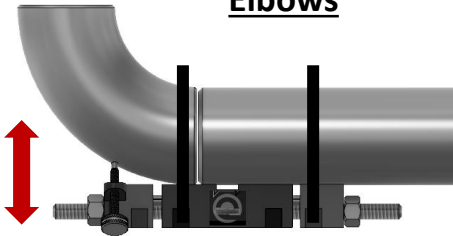

Fitting Installation

1. Secure QFIII clamp to pipe using the adjustable end block and chain clamps (exact location will vary based on pipe size and allows for gap adjustment).
2. Place and secure fitting on saddle end with chain clamps.
3. Level and or square fittings with jack screws as required
4. The opposite end block from the saddle can be used to adjust weld gap if required.

Reducers

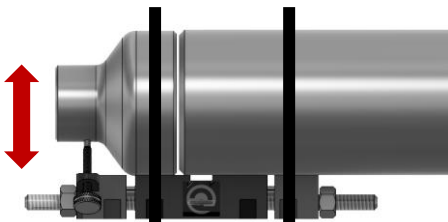

Notes

- Chain clamp location illustrated in black.
- Placement illustrations are only a guide, varying styles of fittings and pipe schedules may require differing placement of pipe and fittings.
- To replace or if additional jack screws are required, 3/8-16 bolts can be used.

Tee's

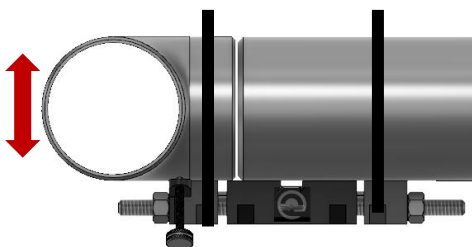



QFIII-SP Hybrid Maintenance & Inspection

Daily inspection is recommended to keep the clamp in good working order. The following is a checklist to document any wear or damage to the unit and if so should be taken out of service for repair or replacement.

ITEM	CHECKED
Guide Rods (Lubricate Regularly)	
Threaded Rods & Nuts (Lubricate Regularly)	
Main & End & Blocks	
Chain Clamps	
Complete Assembly Inspection, (Wear / Damage)	
NOTES (List damage, missing pieces, repairs required, or any other important information needed to ensure the proper operation and safety of the equipment, property and all persons.)	
Completed by: (Name, Company, Department)	Date (ddmmyy)

Important

Along with regular inspections, it is recommended that regular lubrication of both the threaded and guide rods be performed to keep the unit in good working condition.

Promptly contact QFInnovations at info@qfinnovations.com or your local distributor to report any defects, faulty workmanship or warranty issues. A unit serial number can be found on the inside of the QFIII-SP case and will be required for any warranty issues.



QFIII-SP Hybrid Fitting Saddle Assembly



QFIII-SP Fitting Saddle & Jackscrews Saddle Installation

1. Locate tapped clamp end block and remove positioning nut.

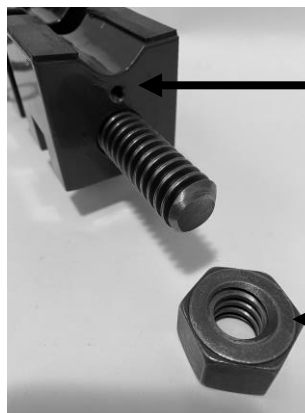

Tapped End
Block

Remove
Positioning Nut

2. Slide saddle over threaded rod to end block and install provided bolt with 5/32 allen wrench.



Slide On Saddle

Install And
Tighten Provided
Bolt

3. Reinstall Positioning Nut Onto Threaded Rod.