



THE SSC CONTROLS COMPANY

PREMIER INDUSTRIAL CONTROLS

Product Information Sheet

C850-0825 TIG Welding Foot Control

The C800 foot controls are dependable workhorses with high-performance characteristics. The C850-0825 is designed for use with Thermal Arc® TIG welding machines which use the Thermal Arc® 10-4015 and 10-4016 foot controls. Designed for the pro, these rugged and dependable controls provide a tremendous value. They contain a patented design that improves low-current welding while providing classic arc control.

The design features a durable 16-gauge steel case, oversized top traction area, non-slip 3M® traction pads, comfortable at-rest and operating foot positions, heavy-duty cable, and precision components. Simply press the pedal to activate the gas contactor and increase current; release the pedal to turn off the weld output and activate the afterflow cycle. Includes a 25-foot cable and 8-pin plug, which mate to the power source.

- Patented design is tested to one million lifecycles.
- Designed and manufactured under a quality system certified to ISO 9001 requirements.
- Replaces Thermal Arc® part numbers 10-4015, 10-4016, and 600285.
- 1-year warranty on parts and labor.
- Made in USA.



Dimensions, L x W x H, in. (cm.):
8.8 x 5.5 x 4 (22.4 x 14.0 x 10.2)

Weight, pounds (kg.): 6.1 (2.8)

Certification: CSA NRTL/C

Patent: 5,535,642

Finish: powder paint, black

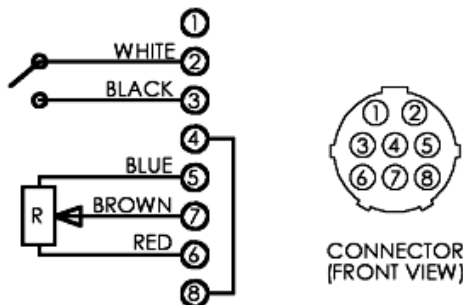

Wiring Diagram
C850-0825 Foot Control

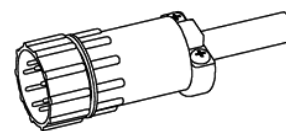

8-pin Amp® connector



Warning: Disconnect input power to the power source before installing or removing this control.

The SSC Controls Company
8909 East Avenue Mentor, Ohio 44060
Phone: 440 205-1600 Fax: 440 205-1700