



Digital Elite Series With External Grind Button

Auto-Darkening Helmets



OWNER'S MANUAL

TABLE OF CONTENTS

SECTION 1 – SAFETY PRECAUTIONS – READ BEFORE USING	1
1-1 Symbol Usage	1
1-2 Arc Welding Hazards	1
1-3 California Proposition 65 Warnings	3
1-4 Lens Shade Selection Table	3
1-5 Principal Safety Standards	4
SECTION 2 – CONSIGNES DE SÉCURITÉ - LIRE AVANT UTILISATION	5
2-1 Symboles utilisés	5
2-2 Dangers concernant le soudage à l'arc	5
2-3 Proposition californienne 65 Avertissements	7
2-4 Tableau de sélection du vignettage	7
2-5 Principales normes de sécurité	8
SECTION 3 – DEFINITIONS	9
3-1 Additional Safety Symbol Definitions	9
3-2 Miscellaneous Symbols And Definitions	9
SECTION 4 – SPECIFICATIONS	10
SECTION 5 – OPERATING INSTRUCTIONS	11
5-1 Helmet Controls	11
5-2 Mode Control Button And Low Battery/Grind/Memory Function Light	12
5-3 Mode Control	13
5-4 Variable Shade Control	14
5-5 Lens Delay Control	15
5-6 Sensitivity Control	16
5-7 Typical Lens Adjustment Procedure	17
5-8 Arc Time And Arc Count Controls	18
5-9 Memory Control	19
SECTION 6 – ADJUSTING HEADGEAR	20
6-1 Adjusting Headgear	20
SECTION 7 – REPLACING LENS COVERS	21
7-1 Replacing Outside Lens Covers	21
7-2 Replacing Inside Lens Cover	22
SECTION 8 – REPLACING THE BATTERIES	23
8-1 Replacing The Batteries	23
SECTION 9 – INSTALLING OPTIONAL MAGNIFYING LENS	24
9-1 Installing Optional Magnifying Lens	24
SECTION 10 – MAINTENANCE AND STORAGE	25
SECTION 11 – TROUBLESHOOTING	26
11-1 Troubleshooting	26
SECTION 12 – PARTS LIST	27
SECTION 13 – LIMITED WARRANTY	29

SECTION 1 – SAFETY PRECAUTIONS – READ BEFORE USING

-  Protect yourself and others from injury—read, follow, and save these important safety precautions and operating instructions.

1-1. Symbol Usage

-  **DANGER!** – Indicates a hazardous situation which, if not avoided, will result in death or serious injury. The possible hazards are shown in the adjoining symbols or explained in the text.

-  Indicates a hazardous situation which, if not avoided, could result in death or serious injury. The possible hazards are shown in the adjoining symbols or explained in the text.

NOTICE – Indicates statements not related to personal injury.

 Indicates special instructions.



This group of symbols means Warning! Watch Out! ELECTRIC SHOCK, MOVING PARTS, and HOT PARTS hazards. Consult symbols and related instructions below for necessary actions to avoid these hazards.

1-2. Arc Welding Hazards

-  The symbols shown below are used throughout this manual to call attention to and identify possible hazards. When you see the symbol, watch out, and follow the related instructions to avoid the hazard. The safety information given below is only a summary of the more complete safety information found in the Principal Safety Standards listed in Section 1-5. Read and follow all Safety Standards.

-  Only qualified persons should install, operate, maintain, and repair this equipment. A qualified person is defined as one who, by possession of a recognized degree, certificate, or professional standing, or who by extensive knowledge, training and experience, has successfully demonstrated the ability to solve or resolve problems relating to the subject matter, the work, or the project and has received safety training to recognize and avoid the hazards involved.

-  During operation, keep everybody, especially children, away.



ARC RAYS can burn eyes and skin.

Arc rays from the welding process produce intense visible and invisible (ultra-violet and infrared) rays that can burn eyes and skin. Sparks fly off from the weld.

- Wear a welding helmet fitted with a proper shade of filter to protect your face and eyes when welding or watching (see ANSI Z49.1 and Z87.1 listed in Principal Safety Standards). Refer to Lens Shade Selection table in Section 1-4.
- Wear approved safety glasses with side shields under your helmet.
- Use protective screens or barriers to protect others from flash, glare, and sparks; warn others not to watch the arc.
- Wear body protection made from durable, flame-resistant material (leather, heavy cotton, wool). Body protection includes oil-free clothing such as leather gloves, heavy shirt, cuffless trousers, high shoes, and a cap.

- Before welding, adjust the auto-darkening lens sensitivity setting to meet the application.
- Stop welding immediately if the auto-darkening lens does not darken when the arc is struck.



NOISE can damage hearing.

Noise from some processes or equipment can damage hearing.

- Wear approved ear protection if noise level is high.



WELDING HELMETS do not provide unlimited eye, ear, and face protection.

Arc rays from the welding process produce intense visible and invisible (ultra-violet and infrared) rays that can burn eyes and skin. Sparks fly off from the weld.

- Use helmet for welding/cutting applications only. Do not use helmet for laser welding/cutting.
- Use impact resistant safety spectacles or goggles and ear protection at all times when using this welding helmet.
- Do not use this helmet while working with or around explosives or corrosive liquids.
- This helmet is not rated for overhead welding. Do not weld in the direct overhead position while using this helmet unless additional precautions are taken to protect yourself from arc rays, spatter, and other hazards.
- Inspect the auto-lens frequently. Immediately replace any scratched, cracked, or pitted cover lenses or auto-lenses.
- Lens and retention components must be installed as instructed in this manual to ensure compliance with ANSI Z87.1 protection standards.
- This helmet provides protection from projectiles associated with grinding, chipping, and related activities; it is not a hard hat and does not provide protection from falling objects.

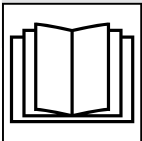

READ INSTRUCTIONS.

- Read and follow all labels and the Owner's Manual carefully before installing, operating, or servicing unit. Read the safety information at the beginning of the manual and in each section.
- Use only genuine replacement parts from the manufacturer.
- Perform installation, maintenance, and service according to the Owner's Manuals, industry standards, and national, state, and local codes.



FUMES AND GASES can be hazardous.

Welding produces fumes and gases. Breathing these fumes and gases can be hazardous to your health.

- Keep your head out of the fumes. Do not breathe the fumes.
- Ventilate the work area and/or use local forced ventilation at the arc to remove welding fumes and gases. The recommended way to determine adequate ventilation is to sample for the composition and quantity of fumes and gases to which personnel are exposed.
- If ventilation is poor, wear an approved air-supplied respirator.
- Read and understand the Safety Data Sheets (SDSs) and the manufacturer's instructions for adhesives, coatings, cleaners, consumables, coolants, degreasers, fluxes, and metals.
- Work in a confined space only if it is well ventilated, or while wearing an air-supplied respirator. Always have a trained watchperson nearby. Welding fumes and gases can displace air and lower the oxygen level causing injury or death. Be sure the breathing air is safe.

- Do not weld in locations near degreasing, cleaning, or spraying operations. The heat and rays of the arc can react with vapors to form highly toxic and irritating gases.
- Do not weld on coated metals, such as galvanized, lead, or cadmium plated steel, unless the coating is removed from the weld area, the area is well ventilated, and while wearing an air-supplied respirator. The coatings and any metals containing these elements can give off toxic fumes if welded.

1-3. California Proposition 65 Warnings

 **WARNING – Cancer and Reproductive Harm — www.P65Warnings.ca.gov.**

1-4. Lens Shade Selection Table

Process	Electrode Size in. (mm)	Arc Current in Amperes	Minimum Protective Shade No.	Suggested Shade No. (Comfort)*
Shielded Metal Arc Welding (SMAW)	Less than 3/32 (2.4)	Less than 60	7	--
	3/32-5/32 (2.4-4.0)	60–160	8	10
	5/32-1/4 (4.0-6.4)	160–250	10	12
	More than 1/4 (6.4)	250–550	11	14
Gas Metal Arc Welding (GMAW) Flux Cored Arc Welding (FCAW)		Less than 60	7	--
		60–160	10	11
		160–250	10	12
		250–500	10	14
Gas Tungsten Arc Welding (TIG)		Less than 50	8	10
		50–150	8	12
		150–500	10	14
Air Carbon Arc Cutting (CAC-A)	Light	Less than 500	10	12
	Heavy	500–1000	11	14
Plasma Arc Cutting (PAC)		Less than 20	4	4
		20–40	5	5
		40–60	6	6
		60–80	8	8
		80–300	8	9
		300–400	9	12
Plasma Arc Welding (PAW)		Less than 20	6	6–8
		20–100	8	10
		100–400	10	12
		400–800	11	14

Reference: ANSI Z49.1:2012

*Start with a shade that is too dark to see the weld zone. Then, go to a lighter shade which gives a sufficient view of the weld zone without going below the minimum.

1-5. Principal Safety Standards

Safety in Welding, Cutting, and Allied Processes, American Welding Society standard ANSI Standard Z49.1. Website: <http://www.aws.org>.

Safe Practice For Occupational And Educational Eye And Face Protection, ANSI Standard Z87.1, from American National Standards Institute. Website: www.ansi.org.

Safety in Welding, Cutting, and Allied Processes, CSA Standard W117.2 from Canadian Standards Association. Website: www.csagroup.org.

Industrial Head Protection, ANSI/ISEA Standard Z89.1 from American National Standards Institute. Website: www.ansi.org.

Australian National Work Health Safety Policy from Safe Work Australia. Website: www.safework-kaustralia.com.

Safety in Welding and Allied Processes, AS1674.1 and AS1674.2 part 1 and 2 from SAI Global. Website: www.saiglobal.com.

Helmet 2020–12

SECTION 2 – CONSIGNES DE SÉCURITÉ - LIRE AVANT UTILISATION

-  Pour écarter les risques de blessure pour vous-même et pour autrui — lire, appliquer et ranger en lieu sûr ces consignes relatives aux précautions de sécurité et au mode opératoire.

2-1. Symboles utilisés

-  **DANGER!** – Indique une situation dangereuse qui si on l'évite pas peut donner la mort ou des blessures graves. Les dangers possibles sont montrés par les symboles joints ou sont expliqués dans le texte.

-  Indique une situation dangereuse qui si on l'évite pas peut donner la mort ou des blessures graves. Les dangers possibles sont montrés par les symboles joints ou sont expliqués dans le texte.

AVIS – Indique des déclarations pas en relation avec des blessures personnelles.

 Indique des instructions spécifiques.



Ce groupe de symboles veut dire Avertissement! Attention! DANGER DE CHOC ELECTRIQUE, PIECES EN MOUVEMENT, et PIECES CHAUDES. Reportez-vous aux symboles et aux directives ci-dessous afin de connaître les mesures à prendre pour éviter tout danger.

2-2. Dangers concernant le soudage à l'arc

-  Les symboles représentés ci-dessous sont utilisés dans ce manuel pour attirer l'attention et identifier les dangers possibles. En présence de ce symbole, prendre garde et suivre les instructions afférentes pour éviter tout risque. Les consignes de sécurité présentées ci-après ne font que résumer l'information contenue dans les Normes de sécurité principales énumérées dans la Section 2-5. Lire et suivre toutes les instructions de sécurité.

-  Une personne qualifiée signifie une personne qui, par l'obtention d'un diplôme reconnu, d'un certificat ou d'un statut professionnel, ou ayant de grandes connaissances, une formation et une expérience, a démontré la capacité à résoudre des problèmes liés au sujet, au travail ou au projet, et ayant reçu une formation de sécurité pour reconnaître et éviter les dangers impliqués.

-  Pendant le fonctionnement, maintenez à distance toutes les personnes, notamment les enfants, de l'appareil.



LES RAYONS DE L'ARC peuvent provoquer des brûlures des yeux et de la peau.

Le rayonnement de l'arc du procédé de soudage génère des rayons visibles et invisibles intenses (ultraviolets et infrarouges) susceptibles de provoquer des brûlures des yeux et de la peau. Des étincelles sont projetées pendant le

soudage.

- Porter un casque de soudage muni d'un écran de filtre approprié pour protéger votre visage et vos yeux pendant le soudage ou pour regarder (voir ANSI Z49.1 et Z87.1 énumérés dans les principales normes de sécurité). Voir le tableau Sélection du vignettage à la section 2-4.
- Porter des protections approuvées pour les oreilles si le niveau sonore est trop élevé.

- Avoir recours à des écrans protecteurs ou à des rideaux pour protéger les autres contre les rayonnements les éblouissements et les étincelles ; prévenir toute personne sur les lieux de ne pas regarder l'arc.
- Porter un équipement de protection pour le corps fait d'un matériau résistant et ignifuge (cuir, coton robuste, laine). La protection du corps comporte des vêtements sans huile, comme des gants de cuir, une chemise solide, des pantalons sans revers, des chaussures hautes et une casquette.
- Avant le soudage, ajuster le réglage de la sensibilité de la lentille auto-obscurcissante en fonction de l'application.
- Arrêter immédiatement le soudage si la lentille auto-obscurcissante ne s'obscurcit pas lorsque l'arc est frappé.

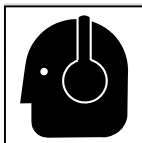

LE BRUIT peut affecter l'ouïe.

Le bruit des processus et des équipements peut affecter l'ouïe.

- Porter des protections approuvées pour les oreilles si le niveau sonore est trop élevé.



Les CASQUES DE SOUDAGE ne fournissent pas une protection illimitée des yeux, des oreilles et du visage.

Le rayonnement de l'arc du procédé de soudage génère des rayons visibles et invisibles intenses (ultraviolets et infrarouges) susceptibles de provoquer des brûlures des yeux et de la peau. Des étincelles sont projetées pendant le

soudage.

- Utiliser uniquement un casque pour les applications de soudage/découpe. Ne pas utiliser le casque pour le soudage/ découpage laser.
- Utiliser en permanence des lunettes de sécurité résistantes aux chocs et des protections auditives lorsque vous portez ce casque de soudage.
- Ne pas porter ce casque lorsque vous travaillez avec ou à proximité d'explosifs ou de liquides corrosifs.
- Ce casque n'est pas évalué pour le soudage à la verticale. Ne pas souder dans une position directement à la verticale tout en utilisant ce casque à moins d'avoir pris des précautions supplémentaires au préalable afin de se protéger contre les rayonnements de l'arc, des projections et d'autres risques.
- Inspecter fréquemment la lentille auto-obscurcissante. Remplacer immédiatement toute lentille de couverture ou auto-obscurcissante rayée, fendue ou piquée.
- La lentille et les composants de rétention doivent être installés comme indiqué dans ce manuel pour assurer la conformité avec les normes de protection ANSI Z87.1.
- Ce casque fournit une protection contre les projectiles associés au meulage, à l'écaillage et aux activités connexes; il ne s'agit pas d'un casque de sécurité, et celui-ci ne protège pas contre les chutes d'objets.

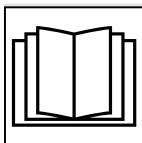

LIRE LES INSTRUCTIONS.

- Lire et appliquer les instructions sur les étiquettes et le Mode d'emploi avant l'installation, l'utilisation ou l'entretien de l'appareil. Lire les informations de sécurité au début du manuel et dans chaque section.
- Utiliser exclusivement les pièces de rechange du fabricant.
- Effectuer l'installation, la maintenance et l'entretien en respectant le Mode d'emploi, les normes industrielles et les codes nationaux, d'état et locaux.

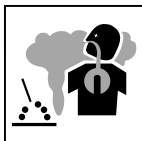

LES FUMÉES ET LES GAZ peuvent être dangereux.

Le soudage produit des vapeurs et des gaz. Respirer ces vapeurs et ces gaz peut être dangereux pour votre santé.

- Écarter la tête des fumées. Ne pas inhaler ces fumées.
- À l'intérieur, ventiler la zone et/ou utiliser une ventilation forcée au niveau de l'arc pour l'évacuation des fumées et des gaz de soudage. Pour déterminer la bonne ventilation, il est recommandé de procéder à un prélèvement pour la composition et la quantité de fumées et de gaz auxquelles est exposé le personnel.
- Si la ventilation est médiocre, porter un respirateur anti-vapeurs approuvé.
- Lire et comprendre les fiches de données de sécurité et les instructions du fabricant concernant les adhésifs, les revêtements, les nettoyants, les consommables, les produits de refroidissement, les dégraisseurs, les flux et les métaux.
- Travailler dans un espace restreint uniquement s'il est bien ventilé ou en portant un respirateur anti-vapeurs. Toujours demander à un surveillant dûment formé de se tenir à proximité. Des fumées et des gaz de soudage peuvent déplacer l'air et abaisser le niveau d'oxygène provoquant des blessures ou des accidents mortels. S'assurer que l'air ambiant est sain pour la santé.
- Ne pas souder dans des endroits situés à proximité d'opérations de dégraissage, de nettoyage ou de pulvérisation. La chaleur et les rayons d'arc peuvent réagir avec les vapeurs et former des gaz hautement toxiques et irritants.
- Ne pas souder des métaux munis d'un revêtement, tels que l'acier galvanisé, plaqué en plomb ou au cadmium à moins que le revêtement n'ait été enlevé dans la zone de soudure, que l'endroit soit bien ventilé et en portant un respirateur à alimentation d'air. Les revêtements et tous les métaux renfermant ces éléments peuvent dégager des fumées toxiques en cas de soudage.

2-3. Proposition californienne 65 Avertissements

⚠ AVERTISSEMENT – Cancer et troubles de la reproduction — www.P65Warnings.ca.gov.

2-4. Tableau de sélection du vignettage

Procédé	Taille d'électrode in. (mm)	Courant d'arc en ampères	N° de classe de protection minimum	Classe de protection suggérée (Comfort)*
Soudage à l'arc métallique avec électrode enrobée (SMAW)	Moins de 3/32 (2,4)	Moins de 60	7	--
	3/32-5/32 (2,4-4,0)	60-160	8	10
	5/32-1/4 (4,0-6,4)	160-250	10	12
	Plus de 1/4 (6,4)	250-550	11	14
Soudage à l'arc MIG/MAG Soudage fil fourré (FCAW)		Moins de 60	7	--
		60-160	10	11
		160-250	10	12
		250-500	10	14
Soudage à l'arc avec électrode en tungstène sous gaz inerte (TIG)		Moins de 50	8	10
		50-150	8	12
		150-500	10	14

Procédé	Taille d'électrode in. (mm)	Courant d'arc en ampères	N° de classe de protection minimum	Classe de protection suggérée (Comfort)*
Coupage arc-air (CAC-A)	Léger	Moins de 500	10	12
	Lourd	500–1000	11	14
Coupage à l'arc plasma		Moins de 20	4	4
		20–40	5	5
		40–60	6	6
		60–80	8	8
		80–300	8	9
		300–400	9	12
Soudage à l'arc plasma (PAW)		400–800	10	14
		Moins de 20	6	6–8
		20–100	8	10
		100–400	10	12
		400–800	11	14

Référence: ANSI Z49.1:2012

*Commencer par une classe de protection trop foncée pour voir la zone de soudage. Ensuite, passer à une classe de protection plus claire, permettant de voir suffisamment la zone de soudage sans aller sous le seuil minimum.

2-5. Principales normes de sécurité

Safety in Welding, Cutting, and Allied Processes, American Welding Society standard ANSI Standard Z49.1. Website: <http://www.aws.org>.

Safe Practice For Occupational And Educational Eye And Face Protection, ANSI Standard Z87.1, from American National Standards Institute. Website: www.ansi.org.

Safety in Welding, Cutting, and Allied Processes, CSA Standard W117.2 from Canadian Standards Association. Website: www.csagroup.org.

Industrial Head Protection, ANSI/ISEA Standard Z89.1 from American National Standards Institute. Website: www.ansi.org.



Australian National Work Health Safety Policy from Safe Work Australia. Website: www.safework-kuustralia.com.

Safety in Welding and Allied Processes, AS1674.1 and AS1674.2 part 1 and 2 from SAI Global. Website: www.saiglobal.com.



Helmet_fre 2020–11

SECTION 3 – DEFINITIONS

3-1. Additional Safety Symbol Definitions



	Warning! Watch Out! There are possible hazards as shown by the symbols.
	Accidental ingestion prevention. Keep battery away from children. Battery is harmful if swallowed.

3-2. Miscellaneous Symbols And Definitions

	Positive
	Negative
	Power On/ Off

SECTION 4 – SPECIFICATIONS

 Please register your product at www.MillerWelds.com/Support/Registration

Specification	Digital Elite Helmet With External Grind Mode Button
Viewing Field	3.81 x 2.37 in. (97 x 60mm)
Operating Modes	Four Modes: Weld, Cut, Grind, X-Mode
Reaction Time	0.00004 sec (1/25,000)
Available Shades <i>All Shades Provide Continuous UV And IR Protection.</i>	<p>Weld Mode Darkened State: No. 8–No. 12.5 Light State: No. 2.5</p> <p>Cut Mode Darkened State: No. 5–No. 8 Light State: No. 2.5</p> <p>Grind Mode Light State: No. 2.5</p> <p>X-Mode Darkened State: No. 8–No. 12.5 Light State: No. 2.5</p>
Sensitivity Control <i>Adjustable For Varying Ambient Light And Welding/Cutting Arc. No. 10 Setting Locks Lens In Dark State.</i>	<p>Weld Mode: No. 0–No. 10</p> <p>Cut Mode: No. 0–No. 10</p> <p>Grind Mode: Not Applicable</p> <p>X-Mode: No. 0–No. 10</p>
Delay Control <i>Slows Lens Dark-To-Light State.</i>	<p>Weld Mode: No. 0–No. 10</p> <p>Cut Mode: No. 0–No. 10</p> <p>Grind Mode: Not Applicable</p> <p>X-Mode No. 0–No. 10</p>
Automatic Power	Shuts lens off 45 minutes after last arc is struck. Lens automatically turns on when arc is struck.
Low Battery Light	Red LED Lights To Indicate 2-3 Days Remaining Battery Life.
Power Supply	Panasonic CR2450 Lithium Batteries (2) (Miller Part No. 217043)
Sensors	Independent/Redundant (Four) And Magnetic (In X-Mode)
Operating Temperature	14°F to 131°F / -10°C to +55°C  <i>When stored in extremely cold temperatures, warm helmet to ambient temperature before welding.</i>
Storage Temperature	-4°F to 158°F / -20°C to +70°C  <i>When stored in extremely cold temperatures, warm helmet to ambient temperature before welding.</i>
Total Weight	18 oz. (510.3 g)
Standards	Meets ANSI Z87.1+ And CSA Z94.3 Standards
Warranty	Four Years From Date Of Purchase (See Section 13)

SECTION 5 – OPERATING INSTRUCTIONS

5-1. Helmet Controls

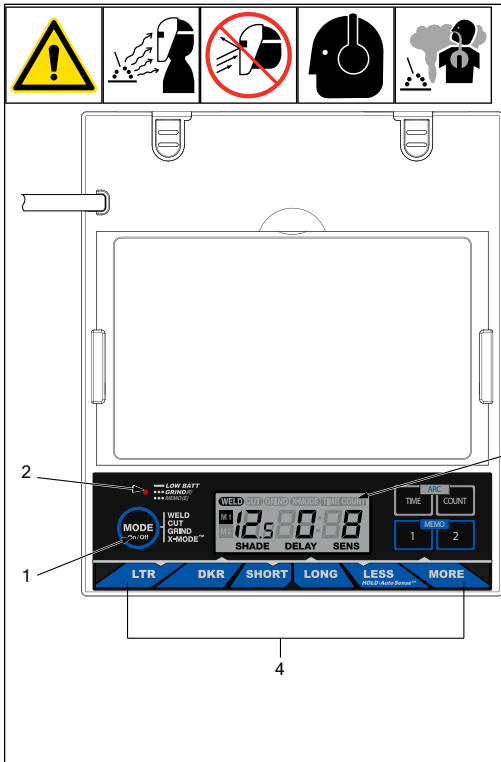

The diagram shows the control panel of a welding helmet. At the top, there are five safety icons: a yellow warning triangle, a person with sparks, a person with a red 'X' over their face, a person with a magnifying glass over their face, and a person with a magnifying glass over their face. Below the icons is the control panel. It features a large display screen in the center. Below the screen is a control panel with a 'MODE' button, a 'WELD SUI' button, and a 'X-ROBE™' button. The display shows 'WELD' and 'COUNT' indicators, a digital readout of '12.5 0.8', and labels for 'SHADE', 'DELAY', and 'SENS'. Below the display are buttons for 'LTR', 'DKR', 'SHORT', 'LONG', 'LESS', and 'MORE'. A 'MEMO' button with '1' and '2' is also present. A 'LOW BATT' indicator is visible at the top left of the panel. Numbered callouts (1-5) point to various features: 1 points to the MODE button, 2 points to the LOW BATT indicator, 3 points to the MEMO buttons, 4 points to the lens assembly, and 5 points to the External Grinding Mode Button (not explicitly labeled in the diagram but implied by the text).

- 1 Mode Control Button (See Section 5-3)
- 2 Low Battery / Grind Mode / Memory Function Light (See Section 5-2)
- 3 Display Screen
- 4 Lens Adjustment Buttons (See Sections 5-4 thru 5-6)
- 5 External Grinding Mode Button (See Section 5-2)

Use adjustment buttons to change shade, delay, and sensitivity settings.

The lens assembly saves the shade, sensitivity, and delay settings.

5-2. Mode Control Button And Low Battery/Grind/Memory Function Light

1 Mode Control Button

Press Mode button to check if the lens is working properly and to begin lens shade, sensitivity, and delay adjustments.

When the Mode button is pressed, the display screen should show the lens settings. Do not use the helmet if the lens does not function as described. (See Section 11-1, Troubleshooting.)

2 Low Battery/Grind/Memory Function Light

The Low Battery/Grind/Memory Function light blinks when the lens is in the Grind mode. Light stays on when 2–3 days of battery life remain.

If battery power is low, replace with Panasonic CR2450 lithium batteries (2 required, Miller Part No. 217043). See Section 8-1.

5-3. Mode Control

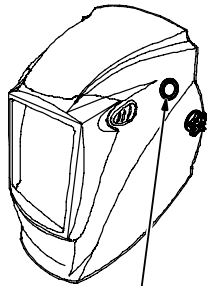
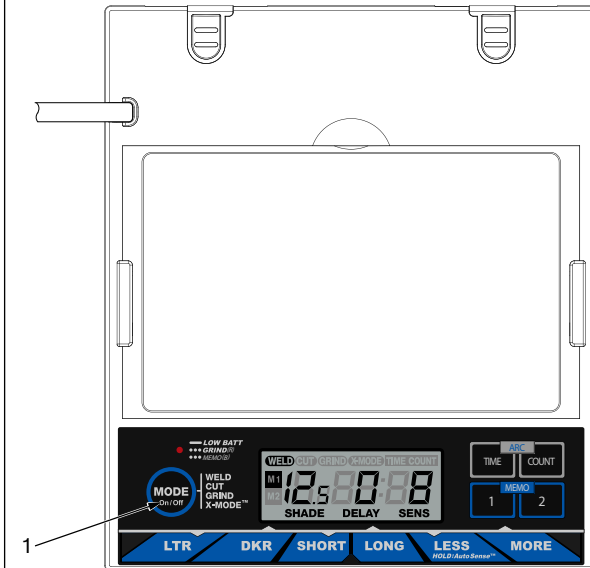
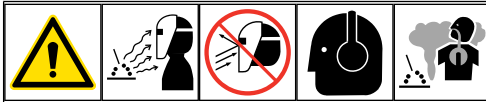

- 1 Mode Control Button
- 2 External Grind Mode Button

Press Mode button to select the mode appropriate for the work activity:

Weld Mode- used for most welding applications. In this mode the lens turns on when it optically senses a welding arc. Adjust shade, sensitivity, and delay settings as needed.

Cut Mode- used for cutting applications. In this mode the lens turns on when it optically senses a cutting arc. Adjust shade, sensitivity, and delay settings as needed.

Grind Mode- used for metal grinding applications. In this mode the shade is fixed shade No. 2.5. No lens adjustments are possible.





Use external Grind Mode button to select grinding mode without raising helmet.

To use Grind mode, push and hold the external Grind button for two seconds. Push Grind button again to turn off Grind mode.

X-Mode- used for outdoor or low current welding applications. In this mode the lens turns on when it senses weld current. Adjust shade, sensitivity, and delay settings as needed.

☞ Nearby welding may affect helmet operation when lens is in X-Mode. Stay at least 12 ft (3.7 m) away from other welding activity.

5-4. Variable Shade Control

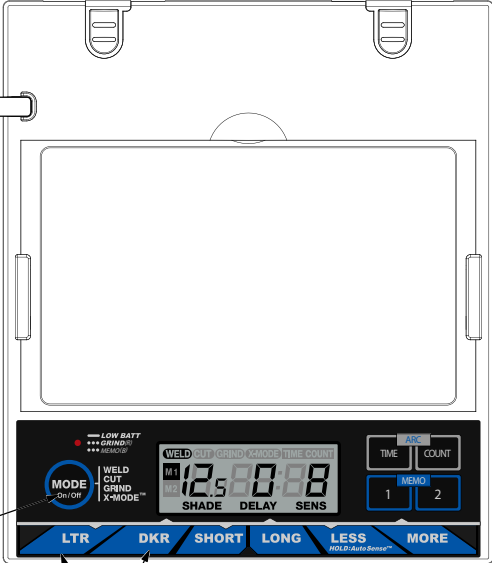

1 Variable Shade Adjustment Buttons

2 Mode Control Button

Use the LTR and DKR adjustment buttons to adjust the lens shade in the darkened state. Use the table in Section 1-4 to select proper shade control setting based on your welding process. The shade ranges for each mode are as follows:

Weld- No. 8–No. 12.5

Cut - No. 5–No. 8

Grind - No. 2.5 only

X-Mode - No. 8–No. 12.5 sensitivity, and delay settings as needed.

Start at the highest setting and adjust lighter to suit the application and your personal preference.

Variable Shade Adjustment Procedure

- Press Mode button to turn lens On.
- Press Mode button to select desired function: Weld, Cut, Grind, or X-Mode.
- Use LTR and DKR adjustment buttons to select desired shade.
- Begin welding or continue with other lens adjustments.

5-5. Lens Delay Control

The diagram shows a control panel for a welding helmet. At the top, there are five safety icons: a yellow warning triangle with an exclamation mark, a person welding with sparks, a person welding with a red prohibition sign over it, a person wearing a helmet, and a person with a cloud of smoke. Below the icons is a large rectangular area representing the helmet's lens. At the bottom is the control panel. On the left is a circular 'MODE' button with 'On/Off' text. To its right is a digital display showing 'WELD CUT GRIND X-MODE TIME COUNT' and 'M 12.5 00.00'. Below the display are 'SHADE', 'DELAY', and 'SENS' indicators. On the right side of the panel are 'TIME' and 'COUNT' buttons, and 'MEMO 1' and 'MEMO 2' buttons. At the bottom are 'LTR', 'DKR', 'SHORT', 'LONG', 'LESS', and 'MORE' buttons. A callout '1' points to the 'SHORT' and 'LONG' buttons, and a callout '2' points to the 'MODE' button.

1 Lens Delay Adjustment Buttons

2 Mode Control Button

Use the Lens Delay Short and Long buttons to adjust the time for the lens to switch to the clear state after welding or cutting.

The delay is particularly useful in eliminating bright after-rays present in higher amperage applications where the molten puddle remains bright momentarily after welding. Use the Lens Delay Control buttons to adjust delay from 0 to 10 (0.1 to 1.0 second).

The delay ranges for each mode are as follows:

Weld, Cut, And X-Modes - No. 0–No. 10

Grind Mode- No delay adjustment

There is no lens delay adjustment in the Grind mode, and in the Cut mode (when sensitivity is set to 10).

Lens Delay Adjustment Procedure

- Press Mode button to turn helmet On.
- Press Mode button to select desired function: Weld, Cut, or X-Mode.
- Use Short and Long adjustment buttons to select desired delay.
- Begin welding or continue with other lens adjustments.

5-6. Sensitivity Control



- 1 Sensitivity Adjustment Buttons
- 2 Mode Control Button

Use control to make the lens more responsive to different light levels in various welding processes. **Use a Mid-Range or 30-50% sensitivity setting for most applications.**

It may be necessary to adjust helmet sensitivity to accommodate different lighting conditions or if lens is flashing On and Off.

The sensitivity ranges for each mode are as follows:

Weld, Cut, X-Modes - 0–10

Grind Mode - No sensitivity adjustment

⚠ Do not weld in the Grind mode; the lens will not darken.

Sensitivity Adjustment Procedure

Adjust helmet sensitivity in lighting conditions helmet will be used in.

- Press Mode button to turn helmet On.
- Press Mode button to select desired function: Weld, Cut, or X-Mode.

- Use Sensitivity Less and More buttons to adjust sensitivity control to lowest setting.
- Face the helmet in the direction of use, exposing it to the surrounding light conditions.
- Press sensitivity More button until the lens darkens, then press Less button until lens clears. An alternative method is to press and hold the Less button until the lens clears.

Helmet is ready for use. Slight readjustment may be necessary for certain applications or if lens is flashing on and off.

Reduce Sensitivity setting if lens stays dark longer than Delay setting.





This lens also features AutoSense[™], which allows users to push and hold only one button for the lens to adjust sensitivity to the proper setting while in Weld mode.

To initiate AutoSense, face helmet toward workpiece and push and hold the Less/AutoSense button until screen indicates that it is adjusting.

Recommended Sensitivity Settings

Stick Electrode	Mid-Range
Short Circuiting (MIG)	Low/Mid-Range
Pulsed And Spray (MIG)	Mid-Range
Gas Tungsten Arc (TIG)	Mid/High-Range
Plasma Arc Cutting/Welding	Low/Mid-Range

5-7. Typical Lens Adjustment Procedure



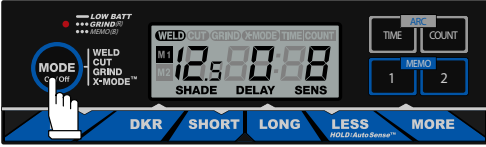







↓



↓



↓



↓



☞ Lens assembly displays prior settings when turned On. Retained settings are not shown in example.

☞ In the Grind mode the lens is a fixed shade No. 2.5. No lens adjustments are possible.

Adjusting Lens Assembly

- Turn lens On. Display screen appears.
- Select mode (Weld, Cut, Grind, X-Mode).
- Select shade by pressing LTR and DKR buttons.
- Select Delay by pressing Short and Long buttons.
- Select Sensitivity by pressing Less and More Buttons.
- Begin work.

5-8. Arc Time And Arc Count Controls

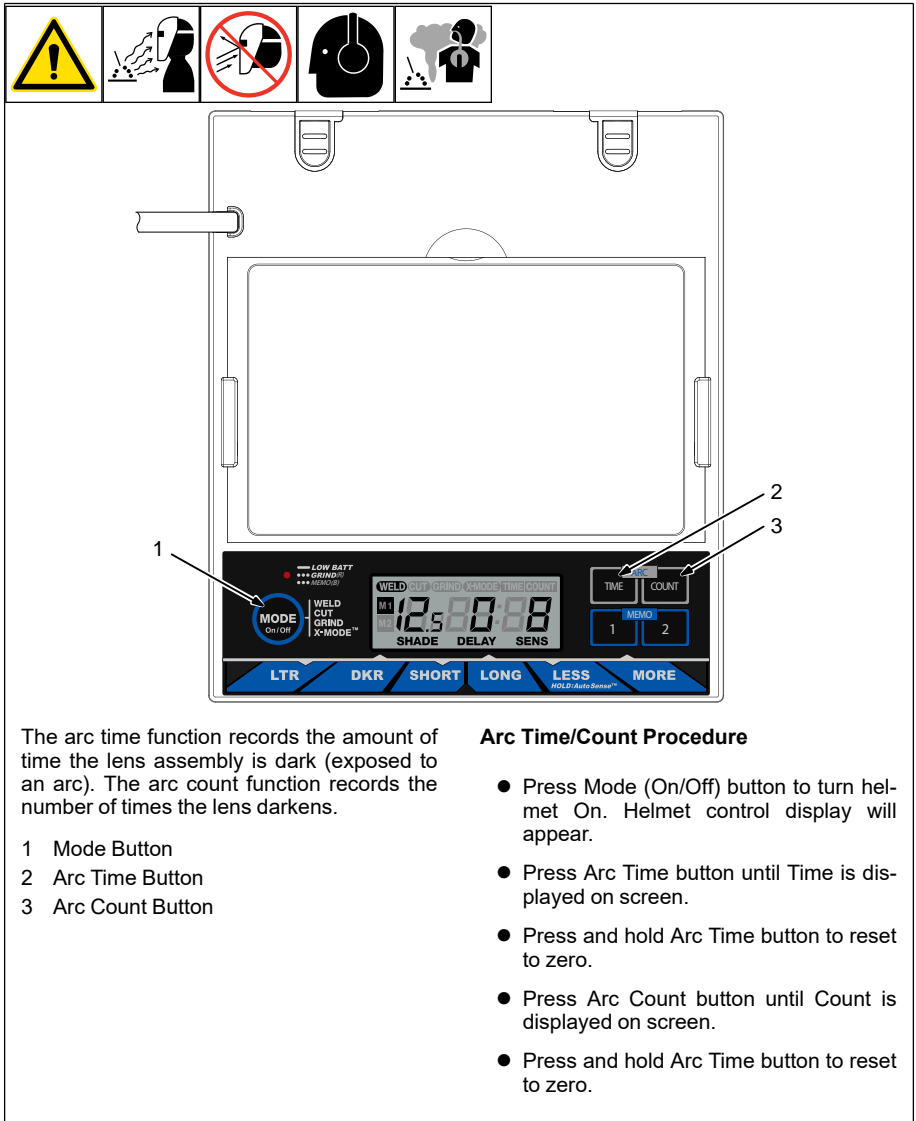

The arc time function records the amount of time the lens assembly is dark (exposed to an arc). The arc count function records the number of times the lens darkens.

- 1 Mode Button
- 2 Arc Time Button
- 3 Arc Count Button

Arc Time/Count Procedure

- Press Mode (On/Off) button to turn helmet On. Helmet control display will appear.
- Press Arc Time button until Time is displayed on screen.
- Press and hold Arc Time button to reset to zero.
- Press Arc Count button until Count is displayed on screen.
- Press and hold Arc Time button to reset to zero.

5-9. Memory Control

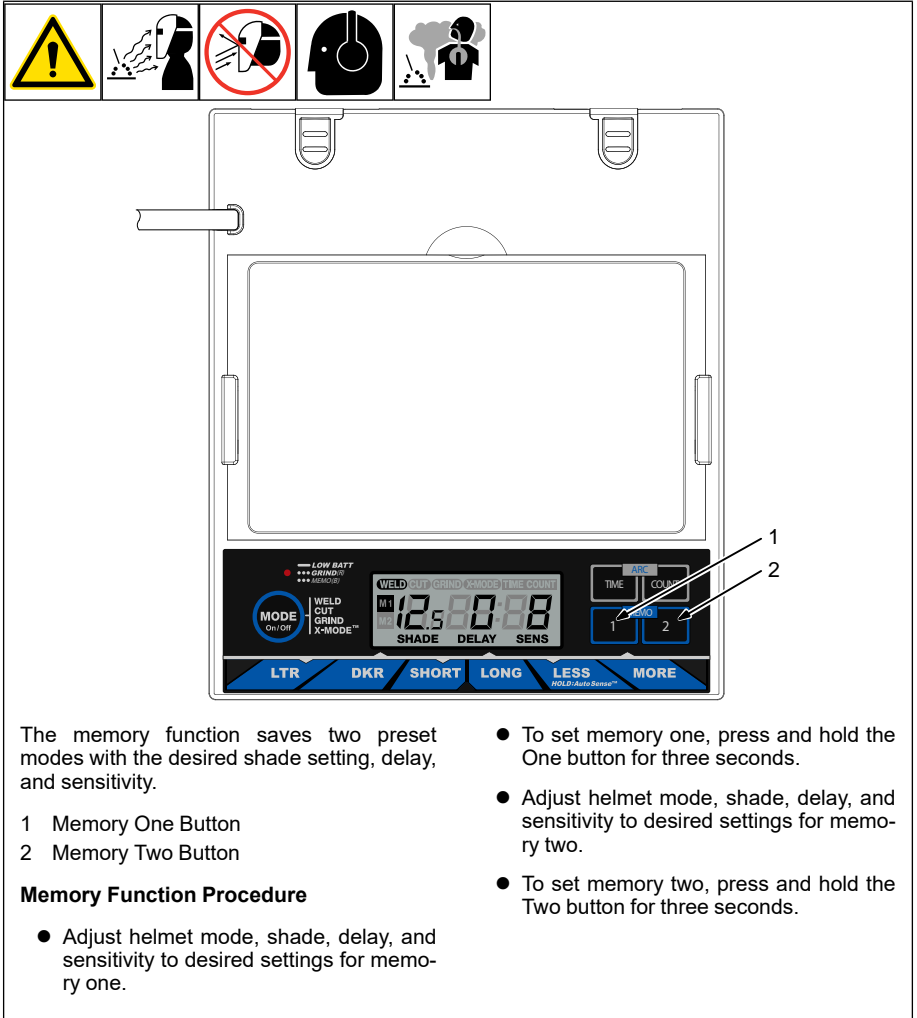

The diagram shows a control panel for a welding helmet. At the top, there are five safety icons: a yellow warning triangle, a person with sparks, a person with a red 'X' over their face, a person with a welding mask, and a person with a welding mask and a red 'X' over their face. Below the icons is a large rectangular area representing the helmet's lens. At the bottom is the control panel. The panel has a digital display showing 'M1 12.5 00:08' and 'SHADE DELAY SENS'. To the left of the display is a 'MODE' button with 'On/Off' and 'WELD CUT GRIND X-NODE™' labels. To the right of the display are 'TIME' and 'COUNT' buttons. Below the display are '1' and '2' buttons, with callout lines 1 and 2 pointing to them. At the bottom of the panel are 'LTR', 'DKR', 'SHORT', 'LONG', 'LESS', and 'MORE' buttons. A 'HOLD' button is also present at the bottom right.

The memory function saves two preset modes with the desired shade setting, delay, and sensitivity.

- 1 Memory One Button
- 2 Memory Two Button

Memory Function Procedure

- Adjust helmet mode, shade, delay, and sensitivity to desired settings for memory one.
- To set memory one, press and hold the One button for three seconds.
- Adjust helmet mode, shade, delay, and sensitivity to desired settings for memory two.
- To set memory two, press and hold the Two button for three seconds.

SECTION 6 – ADJUSTING HEADGEAR

6-1. Adjusting Headgear

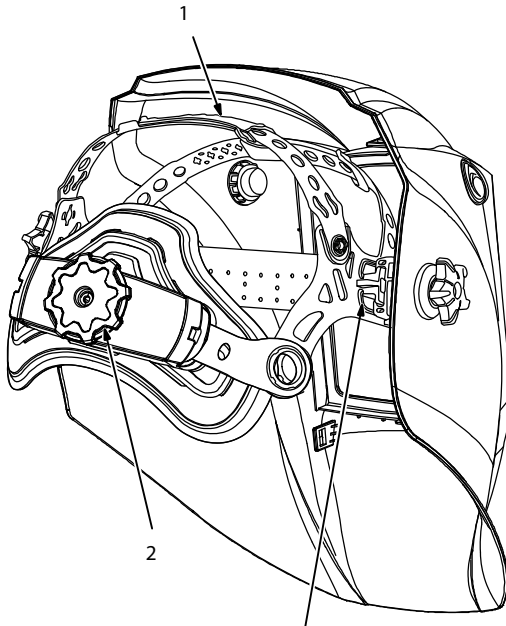
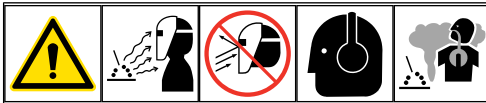

 *There are four headgear adjustments: headgear top, tightness, angle, and distance.*

1 Headgear Top

Adjusts headgear for proper depth on the head to ensure correct balance and stability.

2 Headgear Tightness

To adjust, turn the adjusting knob located on the back of the headgear left or right to desired tightness.

3 Angle Adjustment (Not Shown)

Seven slots on the right side of the headband provide adjustment for the forward tilt of the helmet. To adjust, lift and reposition the control arm to the desired position.

4 Distance Adjustment

Adjusts the distance between the face and the lens. To adjust, press black tabs on the top and bottom of the pivot point and use other hand to slide headgear forward or backward. Release tabs. (Both sides must be equally positioned for proper vision.)

 *Numbers on the adjustment slides indicate set position so both sides can be adjusted equally.*

SECTION 7 – REPLACING LENS COVERS

7-1. Replacing Outside Lens Covers



⚠ Never use the auto-darkening lens without the inside and outside lens covers properly installed. Welding spatter will damage the auto-darkening lens and void the warranty.

- 1 Front Lens Holder
- 2 Release Points
- 3 Lens Cover
- 4 Gasket

Remove front lens holder by pressing release points and pulling the holder away from the helmet.

Remove lens cover and gasket from the holder. Replace lens cover and reinstall gasket and lens in holder. Reinstall holder in helmet.

☞ Be sure the flat side of lens cover gasket faces the lens cover holder.

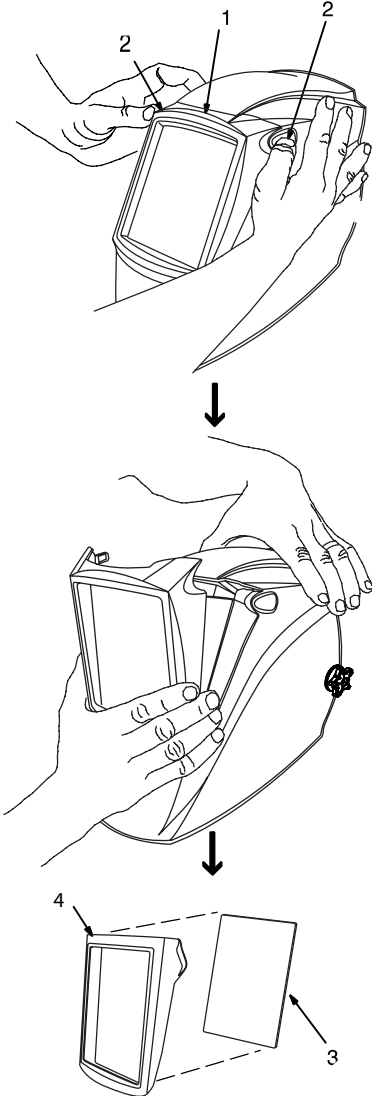

7-2. Replacing Inside Lens Cover

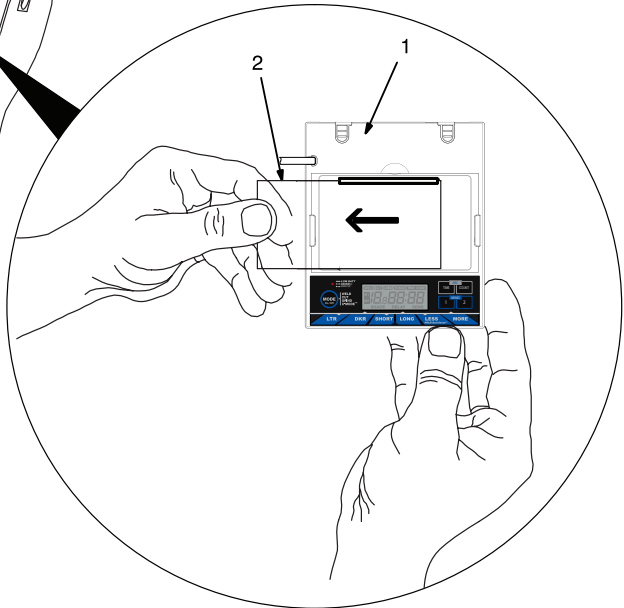
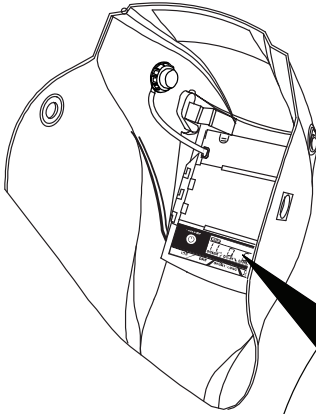

⚠ Never use the auto-darkening lens without the inside and outside lens covers properly installed. Welding spatter will damage the auto-darkening lens and void the warranty.

- 1 Lens Assembly
- 2 Inside Lens Cover

Remove the lens cover holder (see Section 7-1). Remove lens assembly.

Remove the inside lens cover by prying the cover up at either thumbnail opening at each side of the cover. Slide cover out of either side of frame. Replace lens cover and reinstall the assembly in the helmet by reversing the above procedure.

☞ Be sure the cover lens is seated properly (flat) to prevent fogging.

SECTION 8 – REPLACING THE BATTERIES

8-1. Replacing The Batteries

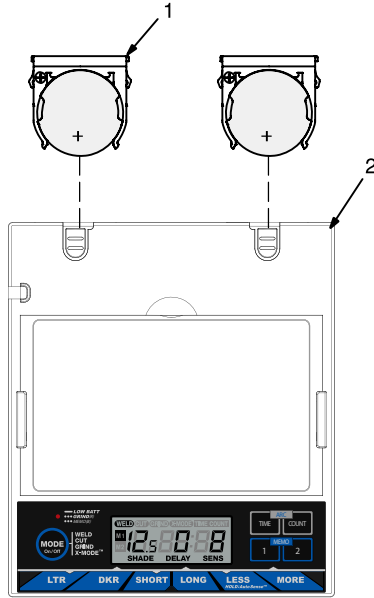
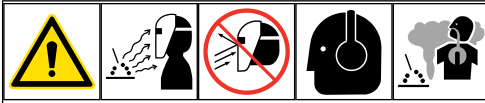

To replace the batteries, remove the auto-darkening lens assembly (see Section 7-1).

- 1 Battery Tray
- 2 Digital Elite Lens

After removing the lens assembly, slide the battery holding trays out and remove the old batteries.

Replace with Panasonic CR2450 lithium batteries (2 required, Miller Part No. 217043).

 Be sure Positive (+) side of the battery faces up (toward inside of helmet).

Reinstall the battery trays. To test, press the On button. The display screen should turn on. Reinstall the lens assembly.

 Left and right battery trays are not interchangeable in the Digital Elite lens assembly. The auto-darkening helmet will not work if battery trays are installed on the wrong sides.

SECTION 9 – INSTALLING OPTIONAL MAGNIFYING LENS

9-1. Installing Optional Magnifying Lens

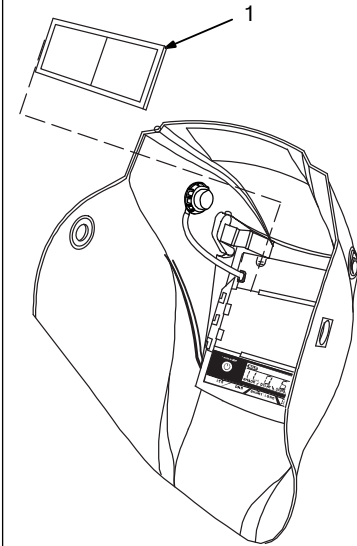
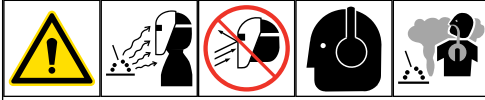

1 Optional Magnifying Lens

Starting at the top, slide magnifying lens into the helmet retaining brackets. Align the magnifying lens with the auto-darkening lens assembly.

Reverse procedure to remove magnifying lens.

To prevent lens fogging, install flat side of magnifying lens toward auto-darkening lens.

SECTION 10 – MAINTENANCE AND STORAGE

 *Do not use solvents or abrasive cleaning detergents to clean the helmet. Do not immerse the lens assembly in water.*

 *Keep helmet dry; do not expose helmet to rain or snow. Keep helmet away from fire and other sources of heat.*

 *The auto-darkening lens uses sensitive electronics. Do not drop helmet or handle it in a rough manner.*

The helmet requires little maintenance. However, for best performance clean helmet after each use. Using a soft cloth dampened with a mild soap and water solution, wipe the cover lenses clean. Allow to air dry. Occasionally, the filter lens and sensors should be cleaned by gently wiping with a soft, dry cloth.

Store helmet in a clean, dry, cool place free of solvent-based vapors. To prevent battery from losing power, store helmet in helmet bag or in a dark location. Remove battery(s) if helmet will be stored longer than six months.

End Of Useful Life

The welding helmet has no expiration date, and with proper care and maintenance it can provide many years of eye and face protection. The helmet can continue to be used, provided that the helmet shell/shroud is undamaged (no cracks, gaps, or holes) and the lens functions normally (switches from a light state to a dark state.)

SECTION 11 – TROUBLESHOOTING

11-1. Troubleshooting



Trouble	Remedy
Auto lens not On – auto-lens does not darken momentarily when the On button is pressed.	Check batteries and verify they are in good condition and installed properly.
	Check battery surfaces and contacts, and clean if necessary.
	Check battery for proper contact and gently adjust contact points if necessary. This is particularly important if the helmet has been dropped.
Not switching – auto-lens stays light and does not darken when welding or cutting.	Stop welding or cutting immediately. Press the On/Off button.
	If power is On, review the sensitivity recommendations and adjust sensitivity.
	Clean lens cover and sensors of any obstructions. Make sure the sensors are facing the arc; angles of 45° or more may not allow the arc light to reach the sensors.
Not Switching – auto-lens stays dark after the arc is extinguished, or the auto-lens stays dark when no arc is present.	Reduce Sensitivity setting. In extreme light conditions, it may be necessary to reduce the surrounding light levels.
Sections of the auto-lens are not going dark, distinct lines separate the light and dark areas.	Stop welding or cutting immediately: The auto-lens may be cracked which can be caused by the impact of dropping the helmet.
	Weld spatter on the auto lens may also cause cracking. (The lens may need to be replaced; most cracked lenses are not covered by warranty).
Switching or Flickering – the auto-lens darkens then lightens while the welding or cutting arc is present.	Review the sensitivity setting recommendations and increase the sensitivity if possible. Be sure the arc sensors are not being blocked from direct access to the arc light.
	Check the lens cover for dirt and spatter that may be blocking the arc sensors. Increasing Lens Delay 0.1 - 0.3 second may also reduce switching.
Inconsistent or lighter auto-lens shading in the dark-state, noticeable on the outside edges and corners.	Referred to as an angle of view effect, auto-darkening lenses have an optimum viewing angle.
	The optimum viewing angle is perpendicular or 90° to the surface of the auto-lens. When that angle of view varies in the dark-state, welders may notice slightly lighter areas at the outside edges and the corners of the lens. This is normal and does not represent any health or safety hazard.
	This effect may also be more noticeable in applications where magnifying lenses are used.

SECTION 12 – PARTS LIST

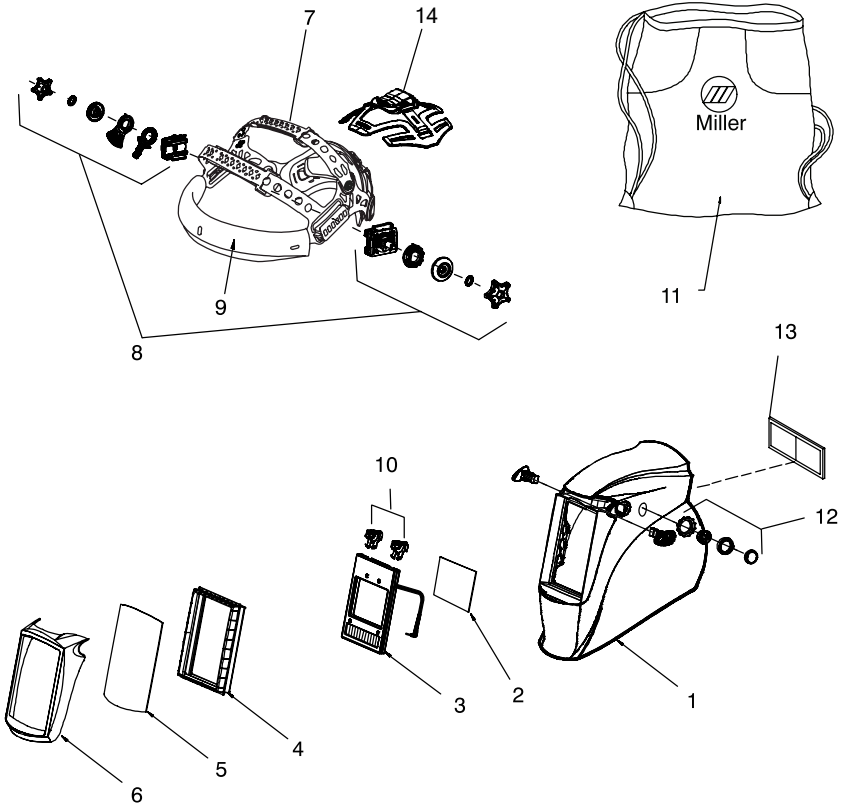

Figure 12-1. Digital Elite Exterior Grind Auto-Darkening Welding Helmet

Digital Elite Exterior Grind Auto-Darkening Welding Helmet

Item No.	Part No.	Description	Qty.
1	288927	Helmet Shell, Grind Button Hole (Elite)	1
	216714	Label, Warning Helmet En/Sp/Fr	1
2	216327	Inside Lens Cover (4–1/4 X 2–1/2) (5 Per Pkg.)	1
3	289876	Auto-Darkening Elite Ext Grind Lens Assembly	1
4	241977	Gasket, Lens Assembly	1
5	216326	Outside Lens Cover (4–11/16 X 5–5/8) (5 Per Pkg.)	1
6	241978	Front Lens Holder (Black)	1
7	284218	Headgear, Grey (Gen 3.5) (Includes Items 8 And 9)	1
8	*256178	Adjustment Angle/Stop Hardware Kit	1
9	770249	—Fabric Headband	1
	079975	—Replacement O-Rings For Kit 256 178 (5 Per Pkg.)	1
10	216339	Battery Tray Kit (Left/Right)	1
11	770250	Helmet Bag - Miller	1
	217043	Battery, Lithium (CR2450)	2
	◆222003	Hard Hat Adapters, Band (Not Shown)	1
	◆259637	Adapters, Slotted Hard Hat (Not Shown)	1
12	256179	Button, Grind Mode	1
13	◆212235	Lens, 0.75 Magnification	1
	◆212236	Lens, 1.00 Magnification	1
	◆212237	Lens, 1.25 Magnification	1
	◆212238	Lens, 1.50 Magnification	1
	◆212239	Lens, 1.75 Magnification	1
	◆212240	Lens, 2.00 Magnification	1
	◆212241	Lens, 2.25 Magnification	1
	◆212242	Lens, 2.50 Magnification	1
14	◆271326	Cushion, Top Headgear	1

* Adjustment Hardware Kit With O-Rings.

◆ Optional

SECTION 13 – LIMITED WARRANTY

LIMITED WARRANTY— Subject to the terms and conditions below. Miller Electric Mfg. LLC, Appleton, Wisconsin, warrants to its original retail purchaser that the new Miller equipment sold after the effective date of this limited warranty is free of defects in material and workmanship at the time it is shipped by Miller. THIS WARRANTY IS EXPRESSLY IN LIEU OF ALL OTHER WARRANTIES, EXPRESS OR IMPLIED, INCLUDING THE WARRANTIES OF MERCHANTABILITY AND FITNESS.

This Miller auto-darkening lens helmet is warranted for 4 years from the date of purchase. *Proof of purchase is required for warranty transactions so it is imperative that a copy of the original invoice or sales receipt be retained.*

This warranty provides specific legal rights, and other rights may be available depending on your state or province.

For warranty transactions, contact your Miller Distributor.

Miller Helmet4 2021-03

Effective January 1, 2021

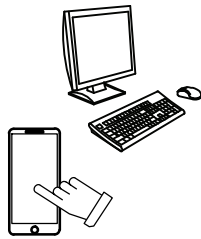

For product information,
Owner's Manual translations,
and more, visit

www.MillerWelds.com