

**TransSteel 2500c**  
**TransSteel 2500c MV**  
**TransSteel 2700c**  
**TransSteel 2700c MV**  
**TransSteel 3500c**

Operating Instructions

EN

MIG/MAG Power source

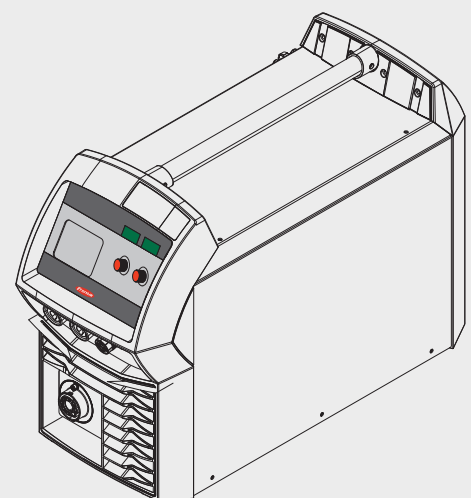



# Dear reader,

## Introduction

Thank you for the trust you have placed in our company and congratulations on buying this high-quality Fronius product. These instructions will help you familiarise yourself with the product. Reading the instructions carefully will enable you to learn about the many different features it has to offer. This will allow you to make full use of its advantages.

Please also note the safety rules to ensure greater safety when using the product. Careful handling of the product will repay you with years of safe and reliable operation. These are essential prerequisites for excellent results.

## Explanation of safety symbols



**DANGER!** Indicates immediate and real danger. If it is not avoided, death or serious injury will result.



**WARNING!** Indicates a potentially dangerous situation. Death or serious injury may result if appropriate precautions are not taken.



**CAUTION!** Indicates a situation where damage or injury could occur. If it is not avoided, minor injury and/or damage to property may result.



**NOTE!** Indicates a risk of flawed results and possible damage to the equipment.

**IMPORTANT!** Indicates tips for correct operation and other particularly useful information. It does not indicate a potentially damaging or dangerous situation.

If you see any of the symbols depicted in the "Safety rules" chapter, special care is required.



# Contents

Safety rules .....	9
General .....	9
Proper use .....	9
Environmental conditions .....	10
Obligations of the operator .....	10
Obligations of personnel .....	10
Mains connection .....	10
Protecting yourself and others .....	11
Danger from toxic gases and vapours .....	11
Danger from flying sparks .....	12
Risks from mains current and welding current .....	12
Meandering welding currents .....	13
EMC Device Classifications .....	14
EMC measures .....	14
EMF measures .....	14
Specific hazards .....	15
Factors affecting welding results .....	16
Danger from shielding gas cylinders .....	16
Danger from escaping shielding gas .....	17
Safety measures in normal operation .....	17
Commissioning, maintenance and repair .....	18
Safety inspection .....	18
Disposal .....	18
Safety symbols .....	19
Data protection .....	19
Copyright .....	19
<b>General information</b> .....	<b>21</b>
General .....	23
Device concept .....	23
Functional principle .....	23
Application areas .....	23
Warning notices on the device .....	24
System components .....	25
General .....	25
Safety .....	25
Overview .....	25
Options .....	27
VRD: safety function .....	27
VRD: safety principle .....	27
<b>Control elements and connections</b> .....	<b>29</b>
Synergic Central control panel .....	31
General .....	31
Safety .....	31
Synergic control panel .....	31
Service parameters .....	34
Keylock .....	35
Connections, switches and mechanical components .....	36
Front and rear sides, TSt 2500c / TSt 2700c .....	36
Front and rear sides, TSt 3500c .....	37
Side view .....	38
<b>Installation and commissioning</b> .....	<b>39</b>
Minimum equipment needed for welding task .....	41
General .....	41
MIG/MAG welding, gas-cooled .....	41

MIG/MAG welding, water-cooled .....	41
Manual metal arc welding .....	41
Before installation and commissioning .....	42
Safety .....	42
Utilisation for intended purpose only .....	42
Setup regulations .....	42
Mains connection .....	42
Connecting the mains cable .....	44
General .....	44
Stipulated mains cables and strain-relief devices .....	44
Connecting the mains cable .....	44
Fitting the strain-relief device, TSt 2500c MV / TSt 2700c, single-phase operation .....	45
Fitting the strain-relief device, TSt 2500c / TSt 2700c .....	46
Fitting the strain-relief device, TSt 2500c MV / TSt 2700c MV .....	47
Fitting the strain-relief device, TSt 3500c .....	48
Fitting the Canada / U S strain-relief device, TSt 3500c .....	48
Generator-powered operation .....	50
Generator-powered operation .....	50
Single-phase operation .....	51
Single-phase operation .....	51
Explanation of the term „duty cycle“ in single-phase operation .....	52
Welding time in single-phase operation .....	52
Fitting/connecting the system components .....	54
Information on system components .....	54
Mounting on the trolley .....	54
Connecting the gas cylinder .....	54
Connecting a MIG/MAG welding torch .....	55
Establishing a ground (earth) connection .....	56
Inserting/replacing feed rollers .....	56
Inserting the wirepool/basket-type spool .....	57
Feeding in the wire electrode .....	58
Setting the contact pressure .....	60
Adjusting the brake .....	60
Design of the brake .....	61
Start-up .....	62
General .....	62
Prerequisites .....	62
Commissioning .....	62

**Welding** **63**

Power limitation .....	65
Safety function .....	65
MIG/MAG modes .....	66
General .....	66
Symbols and their explanations .....	66
2-step mode .....	67
4-step mode .....	67
Special 4-step mode .....	67
Spot welding .....	67
2-step stitch welding .....	68
4-step stitch welding .....	68
MIG/MAG welding .....	69
Safety .....	69
Overview .....	69
MIG/MAG standard synergic welding .....	70
MIG/MAG standard synergic welding .....	70
Corrections during welding .....	70
MIG/MAG standard manual welding .....	72
General .....	72
Available parameters .....	72
MIG/MAG standard manual welding .....	72
Corrections during welding .....	73
MMA welding .....	74

Safety .....	74
Preparation .....	74
MMA welding .....	74
Corrections during welding .....	75
HotStart function .....	75
Anti-stick function .....	75
Saving and retrieving operating points .....	76
General .....	76
Saving operating points .....	76
Retrieving operating points .....	76
Deleting operating points .....	76
Retrieving operating points on the Up/Down welding torch .....	76

**Setup settings 79**

Setup menu .....	81
General remarks .....	81
Configuring the setup parameters .....	81
Setup parameters for MIG/MAG standard manual welding .....	82
Setup parameters for MIG/MAG standard synergic welding .....	84
Setup parameters for MMA welding .....	86
Setup menu - Level 2 .....	87
Restrictions .....	87
Configuring the setup parameters .....	87
Parameters for MIG/MAG welding in the Setup menu level 2 .....	89
Parameters for manual metal arc (MMA) welding in the Setup menu level 2 .....	90
Measuring welding circuit resistance r .....	91
General .....	91
Measure the welding circuit resistance r .....	91
Displaying welding circuit inductivity L .....	92
General .....	92
Displaying welding circuit inductivity L .....	92
Laying the hosepacks correctly .....	92

**Troubleshooting and maintenance 93**

Troubleshooting .....	95
General .....	95
Safety .....	95
Fault diagnosis .....	95
Displayed service codes .....	98
Care, maintenance and disposal .....	104
General .....	104
Safety .....	104
At every start-up .....	104
If necessary .....	104
Every 2 months .....	104
Every 6 months .....	104
Disposal .....	105
Technical data .....	106
Special voltages .....	106
Explanation of the term "duty cycle" .....	106
TSt 2500c .....	107
TSt 2500c MV .....	108
TSt 2700c .....	110
TSt 2700c MV .....	111
TSt 3500c .....	113
Appendix .....	114
Quick reference .....	114
TSt 2500c / TSt 2700c welding program table .....	116
TSt 2500c USA / TSt 2700c USA welding program table .....	117
TransSteel 3500 Euro welding program tables .....	118
TransSteel 3500 US welding program tables .....	119





# Safety rules

## General



The device is manufactured using state-of-the-art technology and according to recognised safety standards. If used incorrectly or misused, however, it can cause:

- injury or death to the operator or a third party,
- damage to the device and other material assets belonging to the operating company,
- inefficient operation of the device.

---

All persons involved in commissioning, operating, maintaining and servicing the device must:

- be suitably qualified,
- have sufficient knowledge of welding and
- read and follow these operating instructions carefully.

---

The operating instructions must always be at hand wherever the device is being used. In addition to the operating instructions, attention must also be paid to any generally applicable and local regulations regarding accident prevention and environmental protection.

---

All safety and danger notices on the device

- must be in a legible state,
- must not be damaged,
- must not be removed,
- must not be covered, pasted or painted over.

---

For the location of the safety and danger notices on the device, refer to the section headed "General" in the operating instructions for the device. Before switching on the device, rectify any faults that could compromise safety.

**This is for your personal safety!**

## Proper use



The device is to be used exclusively for its intended purpose.

---

The device is intended solely for the welding processes specified on the rating plate.

Any use above and beyond this purpose is deemed improper. The manufacturer shall not be held liable for any damage arising from such usage.

---

Proper use includes:

- carefully reading and following all the instructions given in the operating instructions
- studying and obeying all safety and danger notices carefully
- performing all stipulated inspection and maintenance work.

---

Never use the device for the following purposes:

- Thawing out pipes
- Charging batteries
- Starting engines

---

The device is designed for use in industry and the workshop. The manufacturer accepts no responsibility for any damage caused through use in a domestic setting.

---

The manufacturer likewise accepts no liability for inadequate or incorrect results.

## Environmental conditions



Operation or storage of the device outside the stipulated area will be deemed as not in accordance with the intended purpose. The manufacturer shall not be held liable for any damage arising from such usage.

Ambient temperature range:

- during operation: -10 °C to + 40 °C (14 °F to 104 °F)
- during transport and storage: -20 °C to +55 °C (-4 °F to 131 °F)

Relative humidity:

- up to 50% at 40 °C (104 °F)
- up to 90% at 20 °C (68 °F)

The surrounding air must be free from dust, acids, corrosive gases or substances, etc.

Can be used at altitudes of up to 2000 m (6561 ft. 8.16 in.)

## Obligations of the operator



The operator must only allow persons to work with the device who:

- are familiar with the fundamental instructions regarding safety at work and accident prevention and have been instructed in how to use the device
- have read and understood these operating instructions, especially the section "safety rules", and have confirmed as much with their signatures
- are trained to produce the required results.

Checks must be carried out at regular intervals to ensure that operators are working in a safety-conscious manner.

## Obligations of personnel

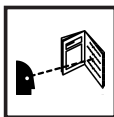

Before using the device, all persons instructed to do so undertake:

- to observe the basic instructions regarding safety at work and accident prevention
- to read these operating instructions, especially the "Safety rules" section and sign to confirm that they have understood them and will follow them.

Before leaving the workplace, ensure that people or property cannot come to any harm in your absence.

## Mains connection

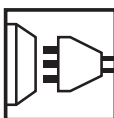

Devices with a higher rating may affect the energy quality of the mains due to their current consumption.

This may affect a number of types of device in terms of:

- connection restrictions
- criteria with regard to the maximum permissible mains impedance <sup>\*)</sup>
- criteria with regard to the minimum short-circuit power requirement <sup>\*)</sup>



<sup>\*)</sup> at the interface with the public grid  
see Technical Data

In this case, the plant operator or the person using the device should check whether the device may be connected, where appropriate by discussing the matter with the power supply company.



**NOTE!** Ensure that the mains connection is earthed properly

**Protecting yourself and others**



Anyone working with the device exposes themselves to numerous risks, e.g.

- flying sparks and hot pieces of metal
- Arc radiation, which can damage eyes and skin



- Hazardous electromagnetic fields, which can endanger the lives of those using cardiac pacemakers



- Risk of electrocution from mains current and welding current



- Greater noise pollution



- Harmful welding fumes and gases

Suitable protective clothing must be worn when working with the device. The protective clothing must have the following properties:

- Flame-resistant
- Insulating and dry
- Covers the whole body, is undamaged and in good condition
- Safety helmet
- Trousers with no turn-ups



Protective clothing refers to a variety of different items. Operators should:

- Protect eyes and face from UV rays, heat and sparks using a protective visor and regulation filter
- Wear regulation protective goggles with side protection behind the protective visor
- Wear stout footwear that provides insulation even in wet conditions
- Protect the hands with suitable gloves (electrically insulated and providing protection against heat)
- Wear ear protection to reduce the harmful effects of noise and to prevent injury



Keep all persons, especially children, out of the working area while any devices are in operation or welding is in progress. If, however, there are people in the vicinity:

- Make them aware of all the dangers (risk of dazzling by the arc, injury from flying sparks, harmful welding fumes, noise, possible risks from mains current and welding current, etc.)
- Provide suitable protective equipment
- Alternatively, erect suitable safety screens/curtains.

**Danger from toxic gases and vapours**



The fumes produced during welding contain harmful gases and vapours.

Welding fumes contain substances that may, under certain circumstances, cause birth defects or cancer.

Keep your face away from welding fumes and gases.

Fumes and hazardous gases

- must not be breathed in
- must be extracted from the working area using appropriate methods.

Ensure an adequate supply of fresh air with a ventilation rate of at least 20 m<sup>3</sup>/hour.

---

Otherwise, a protective mask with an air supply must be worn.

---

Close the shielding gas cylinder valve or main gas supply if no welding is taking place.

---

If there is any doubt about whether the extraction capacity is sufficient, the measured toxic emission values should be compared with the permissible limit values.

---

Amongst others, the following components are responsible for the degree of toxicity of welding fumes:

- Metals used for the workpiece
  - Electrodes
  - Coatings
  - Cleaners, degreasers, etc.
- 

The relevant material safety data sheets and manufacturer's specifications for the listed components should therefore be studied carefully.

---

Flammable vapours (e.g. solvent fumes) should be kept away from the arc's radiation area.

---

---

### Danger from flying sparks



Flying sparks may cause fires or explosions.

---

Never weld close to flammable materials.

---

Flammable materials must be at least 11 metres (36 ft. 1.07 in.) away from the arc, or alternatively covered with an approved cover.

---

A suitable, tested fire extinguisher must be available and ready for use.

---

Sparks and pieces of hot metal may also get into adjacent areas through small gaps or openings. Take appropriate precautions to prevent any danger of injury or fire.

---

Welding must not be performed in areas that are subject to fire or explosion or near sealed tanks, vessels or pipes unless these have been prepared in accordance with the relevant national and international standards.

---

Do not carry out welding on containers that are being or have been used to store gases, propellants, mineral oils or similar products. Residues pose an explosive hazard.

---

---

### Risks from mains current and welding current



An electric shock is potentially life threatening and can be fatal.

---

Do not touch live parts either inside or outside the device.

---



During MIG/MAG welding and TIG welding, the welding wire, the wirespool, the feed rollers and all pieces of metal that are in contact with the welding wire are live.

---

Always set the wirefeeder up on a sufficiently insulated surface or use a suitable, insulated wirefeeder holder.

---

Make sure that you and others are protected with an adequately insulated, dry temporary backing or cover for the earth or ground potential. This temporary backing or cover must extend over the entire area between the body and the earth or ground potential.

---

All cables and leads must be secured, undamaged, insulated and adequately dimensioned. Replace loose connections and scorched, damaged or inadequately dimensioned cables and leads immediately.

Use the handle to ensure the power connections are tight before every use. In the case of power cables with a bayonet connector, rotate the power cable around the longitudinal axis by at least 180° and pre-load.

Do not wrap cables or leads around the body or parts of the body.

The electrode (rod electrode, tungsten electrode, welding wire, etc.) must

- never be immersed in liquid for cooling
- Never touch the electrode when the power source is switched on.

Double the open circuit voltage of a power source can occur between the welding electrodes of two power sources. Touching the potentials of both electrodes at the same time may be fatal under certain circumstances.

Arrange for the mains cable to be checked regularly by a qualified electrician to ensure the ground conductor is functioning properly.

The device must only be operated on a mains supply with a ground conductor and a socket with a ground conductor contact.

Operating the device on a grid without a ground conductor and in a socket without a ground conductor contact will be deemed gross negligence. The manufacturer shall not be held liable for any damage arising from such usage.

If necessary, provide an adequate earth connection for the workpiece.

Switch off unused devices.

Wear a safety harness if working at height.

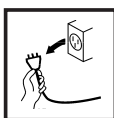

Before working on the device, switch it off and pull out the mains plug.

Attach a clearly legible and easy-to-understand warning sign to the device to prevent anyone from plugging the mains plug back in and switching it on again.

After opening the device:

- Discharge all live components
- Ensure that all components in the device are de-energised

If work on live parts is required, appoint a second person to switch off the main switch at the right moment.

## Meandering welding currents



If the following instructions are ignored, meandering welding currents can develop with the following consequences:

- Fire hazard
- Overheating of parts connected to the workpiece
- Irreparable damage to ground conductors
- Damage to device and other electrical equipment

Ensure that the workpiece is held securely by the workpiece clamp.

Attach the workpiece clamp as close as possible to the area that is to be welded.

If the floor is electrically conductive, the device must be set up with sufficient insulating material to insulate it from the floor.

If distribution boards, twin-head mounts, etc., are being used, note the following: The electrode of the welding torch / electrode holder that is not used is also live. Make sure that the welding torch / electrode holder that is not used is kept sufficiently insulated.

In the case of automated MIG/MAG applications, ensure that only an insulated wire electrode is routed from the welding wire drum, large wirefeeder spool or wirepool to the wire-feed unit.

---

## EMC Device Classifications



Devices in emission class A:

- Are only designed for use in industrial settings
- Can cause line-bound and radiated interference in other areas

---

Devices in emission class B:

- Satisfy the emissions criteria for residential and industrial areas. This is also true for residential areas in which the energy is supplied from the public low-voltage mains.

---

EMC device classification as per the rating plate or technical data.

---

## EMC measures



In certain cases, even though a device complies with the standard limit values for emissions, it may affect the application area for which it was designed (e.g. when there is sensitive equipment at the same location, or if the site where the device is installed is close to either radio or television receivers).

If this is the case, then the operator is obliged to take appropriate action to rectify the situation.

---

Check and evaluate the immunity to interference of nearby devices according to national and international regulations. Examples of equipment that may be susceptible to interference from the device include:

- Safety devices
- Power, signal and data transfer lines
- IT and telecommunications devices
- Measuring and calibrating devices

---

Supporting measures for avoidance of EMC problems:

1. Mains supply
    - If electromagnetic interference arises despite correct mains connection, additional measures are necessary (e.g. use a suitable line filter).
  2. Welding power leads
    - must be kept as short as possible
    - must run close together (to avoid EMF problems)
    - must be kept well apart from other leads
  3. Equipotential bonding
  4. Earthing of the workpiece
    - If necessary, establish an earth connection using suitable capacitors.
  5. Shielding, if necessary
    - Shield off other nearby devices
    - Shield off entire welding installation
- 

## EMF measures



Electromagnetic fields may pose as yet unknown risks to health:

- effects on the health of others in the vicinity, e.g. wearers of pacemakers and hearing aids
- wearers of pacemakers must seek advice from their doctor before approaching the device or any welding that is in progress
- for safety reasons, keep distances between the welding cables and the welder's head/torso as large as possible
- do not carry welding cables and hosepacks over the shoulders or wind them around any part of the body

**Specific hazards**



Keep hands, hair, clothing and tools away from moving parts. For example:

- Fans
- Cogs
- Rollers
- Shafts
- Wirespools and welding wires

Do not reach into the rotating cogs of the wire drive or into rotating drive components.

Covers and side panels may only be opened/removed while maintenance or repair work is being carried out.

During operation

- Ensure that all covers are closed and all side panels are fitted properly.
- Keep all covers and side panels closed.



The welding wire emerging from the welding torch poses a high risk of injury (piercing of the hand, injuries to the face and eyes, etc.).



Therefore always keep the welding torch away from the body (devices with wire-feed unit) and wear suitable protective goggles.



Never touch the workpiece during or after welding - risk of burns.

Slag can jump off cooling workpieces. The specified protective equipment must therefore also be worn when reworking workpieces, and steps must be taken to ensure that other people are also adequately protected.

Welding torches and other parts with a high operating temperature must be allowed to cool down before handling.



Special provisions apply in areas at risk of fire or explosion - observe relevant national and international regulations.



Power sources for work in areas with increased electric risk (e.g. near boilers) must carry the "Safety" sign. However, the power source must not be located in such areas.



Risk of scalding from escaping coolant. Switch off cooling unit before disconnecting coolant flow or return lines.



Observe the information on the coolant safety data sheet when handling coolant. The coolant safety data sheet may be obtained from your service centre or downloaded from the manufacturer's website.



Use only suitable load-carrying equipment supplied by the manufacturer when transporting devices by crane.

- Hook chains and/or ropes onto all suspension points provided on the load-carrying equipment.
- Chains and ropes must be at the smallest angle possible to the vertical.
- Remove gas cylinder and wire-feed unit (MIG/MAG and TIG devices).

If the wire-feed unit is attached to a crane holder during welding, always use a suitable, insulated wirefeeder hoisting attachment (MIG/MAG and TIG devices).



---

If the device has a carrying strap or handle, this is intended solely for carrying by hand. The carrying strap is not to be used if transporting with a crane, counterbalanced lift truck or other mechanical hoist.

---

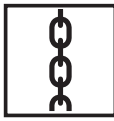

All lifting accessories (straps, handles, chains, etc.) used in connection with the device or its components must be tested regularly (e.g. for mechanical damage, corrosion or changes caused by other environmental factors). The testing interval and scope of testing must comply with applicable national standards and directives as a minimum.

---



Odourless and colourless shielding gas may escape unnoticed if an adapter is used for the shielding gas connection. Prior to assembly, seal the device-side thread of the adapter for the shielding gas connection using suitable Teflon tape.

---

### Factors affecting welding results



The following requirements with regard to shielding gas quality must be met if the welding system is to operate in a correct and safe manner:

- Size of solid matter particles < 40 µm
  - Pressure dew point < -20 °C
  - Max. oil content < 25 mg/m<sup>3</sup>
- 

Filters must be used if necessary.

---



**NOTE!** There is an increased risk of soiling if ring mains are being used

---

### Danger from shielding gas cylinders



Shielding gas cylinders contain gas under pressure and can explode if damaged. As the shielding gas cylinders are part of the welding equipment, they must be handled with the greatest of care.

---

Protect shielding gas cylinders containing compressed gas from excessive heat, mechanical impact, slag, naked flames, sparks and arcs.

---

Mount the shielding gas cylinders vertically and secure according to instructions to prevent them falling over.

---

Keep the shielding gas cylinders well away from any welding or other electrical circuits.

---

Never hang a welding torch on a shielding gas cylinder.

---

Never touch a shielding gas cylinder with an electrode.

---

Risk of explosion - never attempt to weld a pressurised shielding gas cylinder.

---

Only use shielding gas cylinders suitable for the application in hand, along with the correct and appropriate accessories (regulator, hoses and fittings). Only use shielding gas cylinders and accessories that are in good condition.

---

Turn your face to one side when opening the valve of a shielding gas cylinder.

---

Close the shielding gas cylinder valve if no welding is taking place.

---

If the shielding gas cylinder is not connected, leave the valve cap in place on the cylinder.

---

The manufacturer's instructions must be observed as well as applicable national and international regulations for shielding gas cylinders and accessories.

---



**Danger from escaping shielding gas**



Risk of suffocation from the uncontrolled escape of shielding gas

Shielding gas is colourless and odourless and, in the event of a leak, can displace the oxygen in the ambient air.

- Ensure an adequate supply of fresh air with a ventilation rate of at least 20 m<sup>3</sup>/hour.
- Observe safety and maintenance instructions on the shielding gas cylinder or the main gas supply.
- Close the shielding gas cylinder valve or main gas supply if no welding is taking place.
- Check the shielding gas cylinder or main gas supply for uncontrolled gas leakage before every start-up.

**Safety measures in normal operation**



Only operate the device when all safety devices are fully functional. If the safety devices are not fully functional, there is a risk of

- injury or death to the operator or a third party
- damage to the device and other material assets belonging to the operator
- inefficient operation of the device

Any safety devices that are not functioning properly must be repaired before switching on the device.

Never bypass or disable safety devices.

Before switching on the device, ensure that no one is likely to be endangered.

Check the device at least once a week for obvious damage and proper functioning of safety devices.

Always fasten the shielding gas cylinder securely and remove it beforehand if the device is to be transported by crane.

Only the manufacturer's original coolant is suitable for use with our devices due to its properties (electrical conductivity, anti-freeze agent, material compatibility, flammability, etc.).

Only use suitable original coolant from the manufacturer.

Do not mix the manufacturer's original coolant with other coolants.

Only connect the manufacturer's system components to the cooling circuit.

The manufacturer accepts no liability for damage resulting from use of other system components or a different coolant. In addition, all warranty claims will be forfeited.

Cooling Liquid FCL 10/20 does not ignite. The ethanol-based coolant can ignite under certain conditions. Transport the coolant only in its original, sealed containers and keep well away from any sources of ignition.

Used coolant must be disposed of properly in accordance with the relevant national and international regulations. The coolant safety data sheet may be obtained from your service centre or downloaded from the manufacturer's website.

Check the coolant level before starting to weld, while the system is still cool.

---

## Commissioning, maintenance and repair



It is impossible to guarantee that bought-in parts are designed and manufactured to meet the demands made of them, or that they satisfy safety requirements.

- Use only original spare and wearing parts (also applies to standard parts).
- Do not carry out any modifications, alterations, etc. to the device without the manufacturer's consent.
- Components that are not in perfect condition must be replaced immediately.
- When ordering, please give the exact designation and part number as shown in the spare parts list, as well as the serial number of your device.

---

The housing screws provide the ground conductor connection for earthing the housing parts.

Only use original housing screws in the correct number and tightened to the specified torque.

---

## Safety inspection



The manufacturer recommends that a safety inspection of the device is performed at least once every 12 months.

---

The manufacturer recommends that the power source be calibrated during the same 12-month period.

---

A safety inspection should be carried out by a qualified electrician

- after any changes are made
- after any additional parts are installed, or after any conversions
- after repair, care and maintenance has been carried out
- at least every twelve months.

---

For safety inspections, follow the appropriate national and international standards and directives.

---

Further details on safety inspection and calibration can be obtained from your service centre. They will provide you on request with any documents you may require.

---

## Disposal



Do not dispose of this device with normal domestic waste! To comply with the European Directive on Waste Electrical and Electronic Equipment and its implementation as national law, electrical equipment that has reached the end of its life must be collected separately and returned to an approved recycling facility. Any device that you no longer require must either be returned to your dealer or given to one of the approved collection and recycling facilities in your area. Ignoring this European Directive may have potentially adverse effects on the environment and your health!

---

**Safety symbols**



Devices with the CE mark satisfy the essential requirements of the low-voltage and electromagnetic compatibility directives (e.g. relevant product standards of the EN 60 974 series).

Fronius International GmbH hereby declares that the device is compliant with Directive 2014/53/EU. The full text on the EU Declaration of Conformity can be found at the following address: <http://www.fronius.com>



Devices marked with the CSA test mark satisfy the requirements of the relevant standards for Canada and the USA.

---

**Data protection**

The user is responsible for the safekeeping of any changes made to the factory settings. The manufacturer accepts no liability for any deleted personal settings.

---

**Copyright**



Copyright of these operating instructions remains with the manufacturer.

The text and illustrations are all technically correct at the time of printing. We reserve the right to make changes. The contents of the operating instructions shall not provide the basis for any claims whatsoever on the part of the purchaser. If you have any suggestions for improvement, or can point out any mistakes that you have found in the instructions, we will be most grateful for your comments.



# **General information**



## Device concept

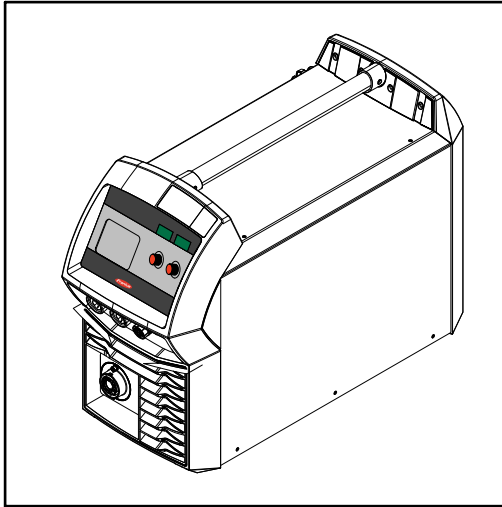

The TransSteel (TSt) 2500c, 2700c and 3500c power sources are completely digitised, microprocessor-controlled inverter power sources.

The modular design and potential for system add-ons ensure a high degree of flexibility. The devices are designed for the welding of steel.

All devices are suitable for:

- MIG/MAG welding
- MMA welding

## Functional principle

The central control and regulation unit of the power sources is coupled with a digital signal processor. The central control and regulation unit and signal processor control the entire welding process.

During the welding process, the actual data is measured continuously and the device responds immediately to any changes. Control algorithms ensure that the desired target state is maintained.

The device has a "Power limitation" safety feature. This means that the power source can be operated at the power limit without compromising process safety.

This results in:

- a precise welding process
- a high degree of reproducibility of all results
- excellent weld properties.

## Application areas

The devices are used in workshops and industry for manual applications with classical steel and galvanised sheets.

The TSt 2500c and TSt 2700c power sources are primarily used in light-gauge steel sheet (light steelwork) applications. Repair, maintenance, and assembly work in shipyards, automotive suppliers, workshops or the furniture construction industry are among the typical application areas. The TSt 2500c et TSt 2700c power sources thus position themselves in their power category between the trade/workshop sector and the industry sector.

The TSt 3500c power sources are designed for:

- Machine and equipment construction
- Steelwork
- Plant and container construction
- Metal and gantry construction
- Rail vehicle construction

**Warning notices on the device**

Warning notices and safety symbols are affixed to the power sources. These warning notices and safety symbols must not be removed or painted over. They warn against operating the device incorrectly, as this may result in serious injury and damage.

<b>WARNING</b>		 <b>ARC RAYS can burn eyes and skin; NOISE can damage hearing.</b> ● Wear welding helmet with correct filter. ● Wear correct eye, ear and body protection.	Read American National Standard Z49.1, "Safety in Welding and Cutting" From American Welding Society, 550 N.W. LeJeune Rd., Miami, FL 33126; OSHA Safety and Health Standards, 29 CFR 1910, from U.S. Government Printing Office, Washington, DC 20402 CSA, W117-2 M87 Code for Safety in Welding and Cutting. 42.0409.5074
<b>Do not Remove, Destroy, Or Cover This Label</b>			
<b>ARC WELDING can be hazardous.</b> ● Read and follow all labels and the Owner's Manual carefully ● Only qualified persons are to install, operate, or service this unit according to all applicable codes and safety practices. ● Keep children away. ● Pacemaker wearers keep away. ● Welding wire and drive parts may be at welding voltage.		 <b>EXPLODING PARTS can injure.</b> ● Failed parts can explode or cause other parts to explode when power is applied. ● Always wear a face shield and long sleeves when servicing.	
 <b>ELECTRIC SHOCK can kill.</b> ● Always wear dry insulating gloves. ● Insulate yourself from work and ground. ● Do not touch live electrical parts. ● Disconnect input power before servicing. ● Keep all panels and covers securely in place.	 <b>ELECTRIC SHOCK can kill; SIGNIFICANT DC VOLTAGE exists after removal of input power</b> ● Always wait 60 seconds after power is turned off before working on unit. ● Check input capacitor voltage, and be sure it is near 0 before touching parts.	<b>AVERTISSEMENT</b>	
 <b>FUMES AND GASES can be hazardous.</b> ● Keep your head out of the fumes. ● Ventilate area, or use breathing device. ● Read Material Safety Data Sheets (MSDSs) and manufacturer's instructions for materials used.	 <b>WELDING can cause fire or explosion.</b> ● Do not weld near flammable material. ● Watch for fire: keep extinguisher nearby. ● Do not locate unit over combustible surfaces. ● Do not weld on closed containers.		 <b>UN CHOC ELECTRIQUE peut être mortel.</b> ● Installation et raccordement de cette machine doivent être conformes à tous les pertinents. <b>SOUDEAGE A L'ARC peut être hasardeux.</b> ● Lire le manuel d'instructions avant utilisation. ● Ne pas installer sur une surface combustible. ● Les fils de soudage et pièces conductrices peuvent être à la tension de soudage.
 <b>WELDING can cause fire or explosion.</b> ● Do not weld near flammable material. ● Watch for fire: keep extinguisher nearby. ● Do not locate unit over combustible surfaces. ● Do not weld on closed containers.			

inside

**Safety symbols on the rating plate**

- Welding is dangerous. The following basic requirements must be met:
- welders must be sufficiently qualified
  - suitable protective equipment must be used
  - all persons not involved in the welding process must be kept at a safe distance

- Do not use the functions described here until you have thoroughly read and understood the following documents:
- these operating instructions
  - all the operating instructions for the system components, especially the safety rules



# System components

## General

The power sources can be operated with various system components and options. This makes it possible to optimise procedures and to simplify machine handling and operation, as necessitated by the particular field of application in which the power source is to be used.

## Safety



**WARNING!** Operating the equipment incorrectly can cause serious injury and damage. Do not use the functions described until you have thoroughly read and understood the following documents:

- these operating instructions
- all the operating instructions for the system components, especially the safety rules

## Overview

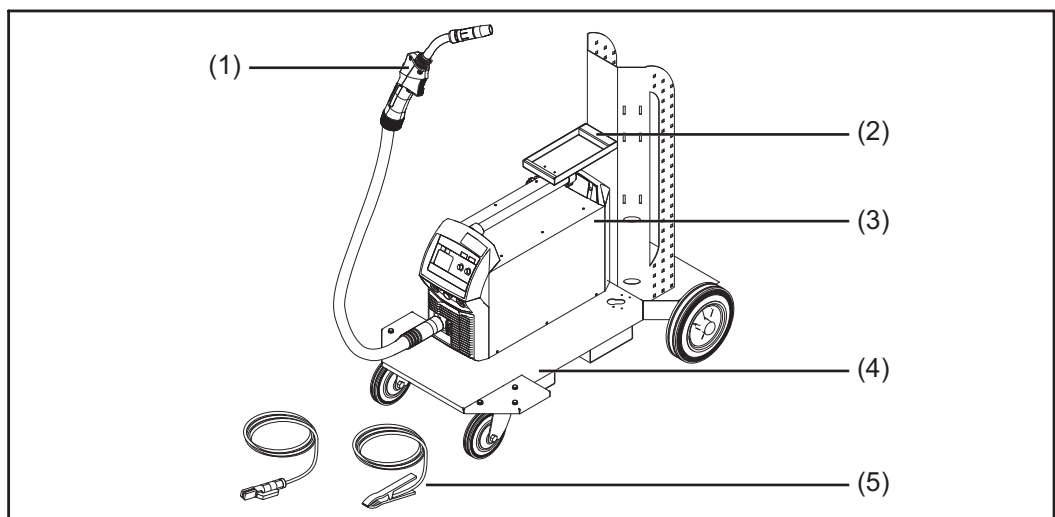

TS2500c / TS2700c

No.	Function
(1)	Welding torch
(2)	Gas cylinder holder stabiliser
(3)	Power source
(4)	Trolley and gas cylinder holder
(5)	Grounding (earthing) cable and electrode cable

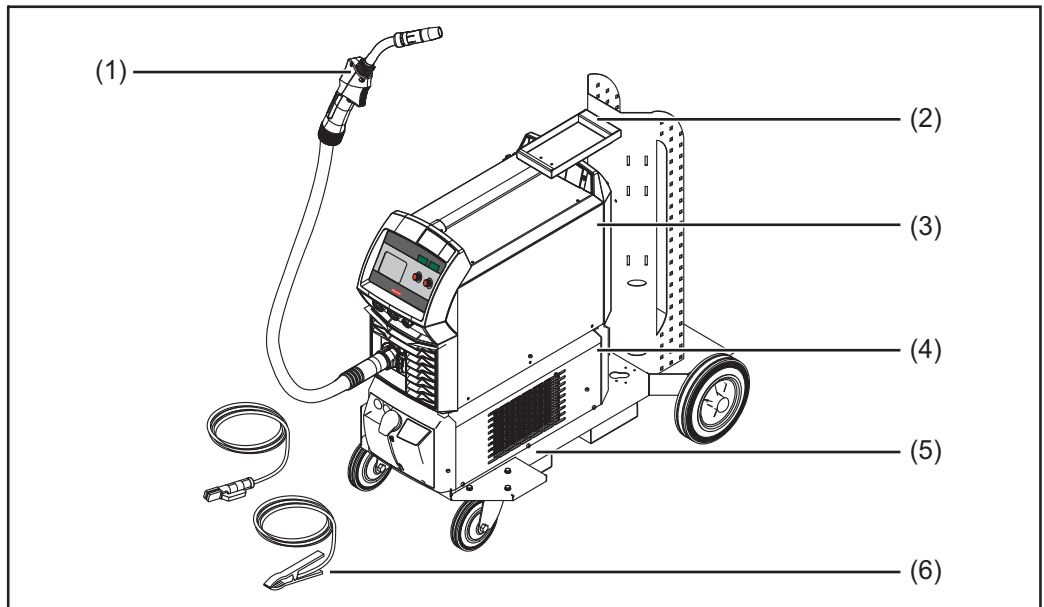

*TSt 3500c*

No.	Function
(1)	<b>Welding torch</b>
(2)	<b>Gas cylinder holder stabiliser</b>
(3)	<b>Power source</b>
(4)	<b>Cooling unit</b> TSt 3500c only
(5)	<b>Trolley and gas cylinder holder</b>
(6)	<b>Grounding (earthing) cable and electrode cable</b>

# Options

## VRD: safety function

A Voltage Reduction Device (VRD) is an optional safety device for reducing the voltage. It is recommended for environments in which the risk of an electric shock or electrical accident is increased considerably during arc welding:

- Due to a low human body resistance of the welder
- If the welder is exposed to a clear risk of touching the workpiece or other parts of the welding circuit

A low human body resistance is possible when there is:

- water in the area
- humidity
- heat, particularly ambient temperatures in excess of 32°C (89.6°F)

In wet, damp or hot locations, humidity or sweat can significantly reduce the skin resistance and the insulation resistance of protective equipment and clothing.

Such environments can include:

- Temporary dams for draining certain areas of a site during construction work (cofferdams)
- Trenches
- Mines
- Rain
- Areas partly submerged by water
- Spraywater areas

The VRD option reduces the voltage between the electrode and the workpiece. In safe conditions, the indicator for the currently selected welding process is permanently lit. A safe condition is defined as follows:

- The output voltage in an open circuit is limited to 35 V.

For as long as the welding operation is active (welding circuit resistance < 200 Ohm), the indicator of the currently selected welding process flashes and the output voltage may exceed 35 V.

## VRD: safety principle

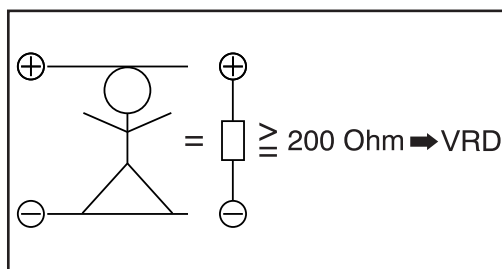

The welding circuit resistance is greater than the minimum human body resistance (greater than or equal to 200 Ohm):

- VRD is active
- Open circuit voltage is limited to 35 V
- Unintentional contact with the output voltage does not put the welder at risk

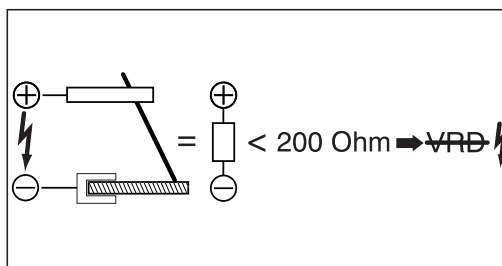

The welding circuit resistance is less than the minimum human body resistance (less than 200 Ohm):

- VRD is inactive
- Output voltage not restricted in order to ensure sufficient welding power
- Example: Welding starts

In MMA welding mode:

Within 0.3 seconds of end of welding:

- VRD is active again
- The output voltage is limited to 35 V once more

# **Control elements and connections**



# Synergic Central control panel

## General

The functions on the control panel are all arranged in a logical way. The individual parameters required for welding can be

- selected easily using buttons
- altered using buttons or the adjusting dial
- displayed on the digital display during welding

The power source uses the Synergic control panel and certain general items of data such as sheet thickness, filler metal, wire diameter and shielding gas to calculate the best welding parameters. As a result, stored knowledge is available at all times. All the parameters can be adjusted manually. The Synergic control panel also allows parameters to be set manually.



**NOTE!** Due to software updates, you may find that your device has certain functions that are not described in these operating instructions or vice versa. Individual illustrations may also differ slightly from the actual controls on your device, but these controls function in exactly the same way.

## Safety





**WARNING!** Operating the equipment incorrectly can cause serious injury and damage. Do not use the functions described until you have thoroughly read and understood the following documents:



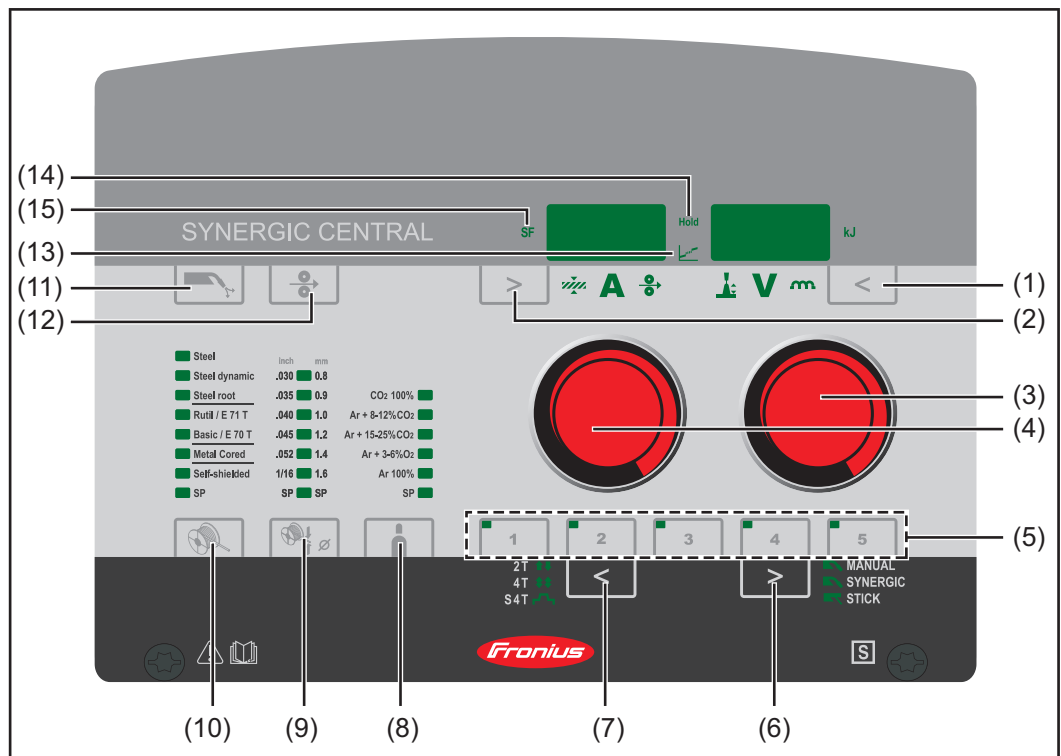



- these operating instructions
- all the operating instructions for the system components, especially the safety rules

## Synergic control panel



No.	Function
(1)	<p><b>"Parameter selection" button (right)</b> for selecting the following welding parameters and for changing parameters in the Setup menu</p> <p>The relevant symbol lights up when a welding parameter is selected.</p> <p> <b>Arc length correction</b> for correcting the arc length</p> <p><b>V Welding voltage in V *)</b> Before the start of welding, the system automatically displays a standard value based on the programmed parameters. During welding, the actual value is displayed.</p> <p><b>m Dynamic</b> for influencing the short-circuiting dynamic at the moment of droplet transfer - ... harder, more stable arc 0 ... neutral arc + ... soft, low-spatter arc</p> <p><b>kJ Real Energy Input</b> for displaying the energy applied during the welding operation. **)</p>
(2)	<p><b>"Parameter selection" button (left)</b> for selecting the following welding parameters and for changing parameters in the Setup menu</p> <p>The relevant symbol lights up when a welding parameter is selected.</p> <p> <b>Sheet thickness in mm or in.</b> If the welding current to be selected is not known it is sufficient to enter the sheet thickness. The required welding current and any other parameters marked with *) will then be adjusted automatically.</p> <p><b>A Welding current in A *)</b> Before the start of welding, the device automatically displays a standard value based on the programmed parameters. During welding, the actual value is displayed.</p> <p> <b>Wire feed speed in m/min or ipm *)</b></p>
(3)	<p><b>Adjusting dial (right)</b> for changing the arc length correction, welding voltage and arc-force dynamic parameters as well as changing parameters in the Setup menu</p>
(4)	<p><b>Adjusting dial (left)</b> for changing the sheet thickness, welding current and wire feed speed parameters as well as changing parameters in the Setup menu</p>
(5)	<p><b>"Save" buttons (Easy Job)</b> for saving up to 5 operating points</p>







- 
- (6) **"Process" button** <sup>\*\*\*</sup>)  
 for selecting the welding process
-  MANUAL - MIG/MAG standard manual welding
  -  SYNERGIC - MIG/MAG standard synergic welding
  -  STICK - manual metal arc welding
- 
- (7) **"Mode" button**  
 for selecting the operating mode
-  2 T - 2-step mode
  -  4 T - 4-step mode
  -  S 4 T - Special 4-step mode
- 
- (8) **"Shielding gas" button**  
 for selecting the shielding gas to be used. Parameter SP is reserved for additional shielding gases.  
 The LED lights up next to the selected shielding gas.
- 
- (9) **"Wire diameter" button**  
 for selecting the wire diameter to be used. Parameter SP is reserved for additional wire diameters.  
 The LED lights up next to the selected wire diameter.
- 
- (10) **"Material" button**  
 for selecting the filler metal to be used. Parameter SP is reserved for additional filler metals.  
 The LED lights up next to the selected filler metal.
- 
- (11) **"Gas-test" button**  
 to set the required gas flow rate at the pressure regulator.  
 Tap button once: shielding gas flows out  
 Tap button again: shielding gas flow stops  
 If the "Gas-test" button is not tapped again, the shielding gas flow will stop after 30 s.
- 
- (12) **"Wire threading" button**  
 Press and hold the button:  
 Thread the wire into the torch hosepack with no accompanying flow of gas  
 While the button is being held down, the wire drive runs at feeder inching speed.
- 
- (13) **Intermediate arc indicator**  
 A spatter-prone "intermediate arc" occurs between the dip transfer arc and the spray arc. To alert you to this critical area - and help you avoid it - the intermediate arc indicator lights up.
- 
- (14) **HOLD indicator**  
 At the end of each welding operation, the actual values for welding current and welding voltage are stored, and the HOLD indicator lights up.
- 
- (15) **SF - spot / stitch welding indicator**  
 lights up if a value has been entered for the spot / stitch welding time Setup parameter (SPt) (spot or stitch welding operating mode is enabled)
-

- \*) If one of these parameters is selected in the MIG/MAG standard synergic welding process, then the synergic function ensures that all other parameters, including the welding voltage parameter, are adjusted automatically.
- \*\*\*) The Real Energy Input display must be activated in level 2 of the Setup menu – EnE parameter. The value continuously rises during welding in line with the permanently increasing energy yield. The final value at the end of welding remains stored until welding starts again or the power source is switched back on - the HOLD indicator lights up.
- \*\*\*\*) In conjunction with the VRD option, the currently selected welding process indicator is simultaneously an additional indicator:
  - The indicator is permanently lit: The Voltage Reduction Device (VRD) is active and is limiting the output voltage to less than 35 V.
  - The indicator starts to flash as soon as a welding action starts in which the output voltage can exceed 35 V.

## Service parameters



Various service parameters can be retrieved by pressing the "Parameter selection" buttons at the same time.

### Opening the display

-  **1** Press and hold the "Parameter selection" button (left)
-  **2** Press the "Parameter selection" button (right)
-   **3** Release the "Parameter selection" buttons

The first parameter ("Firmware version") is displayed, e.g. "1.00 | 4.21"

### Selecting parameters

-   **1** Select the required setup parameter using the "Mode" and "Process" buttons or the left-hand adjusting dial



### Available parameters





Example: 1.00   4.21	Firmware version
Example: 2   491	Welding program configuration
Example: r 2   290	Number of the currently selected welding program
Example: iFd   0.0	Motor current for wire drive in A The value changes as soon as the motor is running.
654   32.1 = 65,432.1 hours = 65,432 hours 6 mins	Indicates the actual arc time since using for the first time Note: The arc time indicator is not suitable as a basis for calculating hiring fees, for warranty purposes, etc.
2nd	2nd menu level for service engineers

## Keylock

A keylock can be selected to prevent the settings from being inadvertently changed on the control panel. As long as the keylock is active

- no settings can be made on the control panel
- only parameter settings can be retrieved
- any assigned "Save" button can be retrieved provided that an assigned "Save" button was selected when the keylock was enabled

Activate/deactivate the keylock as follows:

-  **1** Press and hold the "Mode" button
-  **2** Press the "Parameter selection" button (right)
-   **3** Release the "Mode" and "Parameter Selection" buttons

Keylock activated:

The message "CLO | SEd" appears on the displays.

Keylock deactivated:

The message "OP | En" appears on the displays.

# Connections, switches and mechanical components

Front and rear sides, TSt 2500c / TSt 2700c

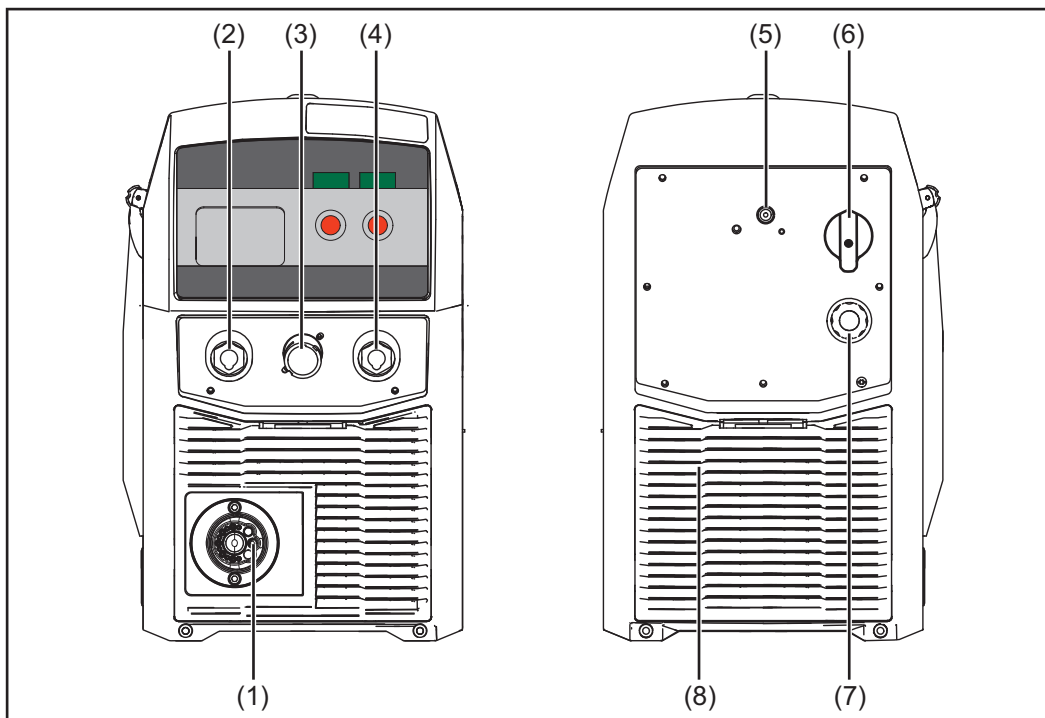

TSt 2500c / TSt 2700c

No.	Function
(1)	<b>Welding torch connection</b> for connecting the welding torch
(2)	<b>(-) - Current socket with bayonet latch</b> used for <ul style="list-style-type: none"> <li>- connecting the grounding (earthing) cable during MIG/MAG welding</li> <li>- connecting the electrode cable or grounding (earthing) cable during MMA welding (depending on the type of electrode used)</li> </ul>
(3)	<b>LocalNet connection</b> Standardised connection for remote control
(4)	<b>(+) - Current socket with bayonet latch</b> used for <ul style="list-style-type: none"> <li>- connecting the electrode cable or grounding (earthing) cable during MMA welding (depending on the type of electrode used)</li> </ul>
(5)	<b>Shielding gas connection</b>
(6)	<b>Mains switch</b> for switching the power source on and off
(7)	<b>Mains cable with strain relief device</b>
(8)	<b>Air filter</b>

Front and rear  
sides, TSt 3500c

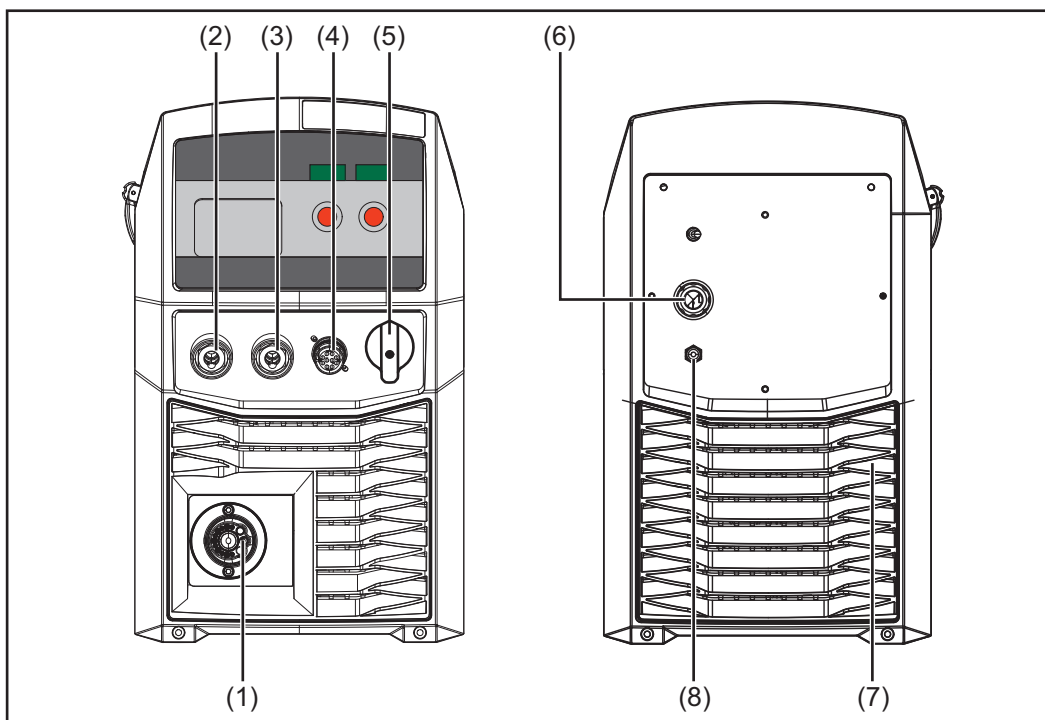

TSt 3500c

No.	Function
(1)	<b>Welding torch connection</b> for connecting the welding torch
(2)	<b>(-) - Current socket with bayonet latch</b> used for <ul style="list-style-type: none"> <li>- connecting the grounding (earthing) cable during MIG/MAG welding</li> <li>- connecting the electrode cable or grounding (earthing) cable during MMA welding (depending on the type of electrode used)</li> </ul>
(3)	<b>(+) - Current socket with bayonet latch</b> used for <ul style="list-style-type: none"> <li>- connecting the electrode cable or grounding (earthing) cable during MMA welding (depending on the type of electrode used)</li> </ul>
(4)	<b>LocalNet connection</b> Standardised connection for remote control
(5)	<b>Mains switch</b> for switching the power source on and off
(6)	<b>Mains cable with strain relief device</b>
(7)	<b>Air filter</b>
(8)	<b>Shielding gas connection</b>

Side view

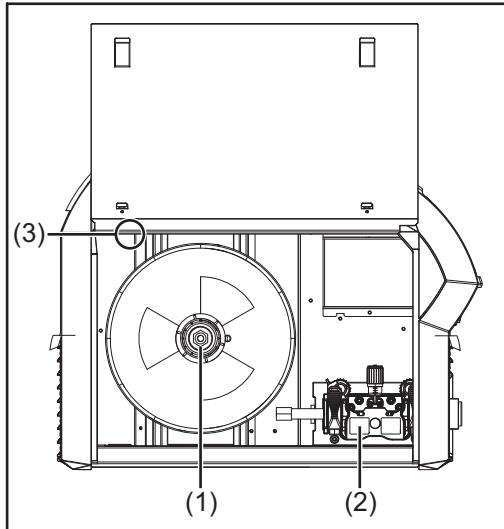

No.	Function
(1)	<b>Wirespool holder with brake</b> for holding standard wirespools with a max. diameter of 300 mm (11.81 in.) and a max. weight of up to 19 kg (41.89 lbs.)
(2)	<b>4-roller drive</b>
(3)	<b>LED wirespool interior lighting (TSt 2500c, TSt 2700c only)</b> with the setup parameter LED the turn-off time is adjustable

# **Installation and commissioning**





# Minimum equipment needed for welding task

---

## General

Depending on which welding process you intend to use, a certain minimum equipment level will be needed in order to work with the power source.  
The welding processes and the minimum equipment levels required for the welding task are then described.

---

## MIG/MAG welding, gas-cooled

- Power source
  - Grounding (earthing) cable
  - MIG/MAG welding torch, gas-cooled
  - Gas connection (shielding gas supply)
  - Wire electrode
- 

## MIG/MAG welding, water-cooled

- Power source
  - Cooling unit including coolant
  - Grounding (earthing) cable
  - MIG/MAG welding torch, water-cooled
  - Gas connection (shielding gas supply)
  - Wire electrode
- 

## Manual metal arc welding

- Power source
- Grounding (earthing) cable
- Electrode holder
- Rod electrode

# Before installation and commissioning

---

## Safety



**WARNING!** Operating the equipment incorrectly can cause serious injury and damage. Do not use the functions described until you have thoroughly read and understood the following documents:

- these operating instructions
- all the operating instructions for the system components, especially the safety rules



**WARNING!** An electric shock can be fatal. If the power source is connected to the mains electricity supply during installation, there is a high risk of very serious injury and damage. Before carrying out any work on the device make sure that:

- the power source mains switch is in the "O" position
- the power source is unplugged from the mains

---

## Utilisation for intended purpose only

The power source may only be used for MIG/MAG and MMA welding. Any other form of usage is deemed "not in accordance with the intended purpose". The manufacturer shall not be held liable for any damages arising from such usage.

Utilisation in accordance with the "intended purpose" also comprises

- following all the information in the operating instructions
- carrying out all the specified inspection and servicing work

---

## Setup regulations

The device is tested to IP 23, meaning:

- protection against penetration by solid foreign bodies with diameters > 12 mm (0.49 in.)
- protection against water sprayed directly at any angle up to 60° from the vertical

The device can be set up and operated outdoors in accordance with degree of protection IP 23.

Avoid direct wetting (e.g. from rain).



**WARNING!** If one of these machines topples over or falls it could cause serious or even fatal injury. Place device on a solid, level surface in such a way that it remains stable.



**CAUTION!** Electroconductive metallic dust may damage the device. The air filter is a very important safety feature for achieving IP 23. Always fit the air filter when operating the device.

The venting duct is a very important safety feature. When choosing the installation location, ensure that the cooling air can enter and exit unhindered through the air ducts on the front and back of the device. Electroconductive metallic dust (e.g. from grinding work) must not be allowed to get sucked into the device.

---

## Mains connection

The devices are designed to run on the mains voltage shown on the respective rating plates. If your version of the device does not come with mains cables and plugs ready-fitted, these must be fitted in accordance with national regulations and standards. For details of fuse protection of the mains lead, please see the Technical Data.



**NOTE!** Inadequately dimensioned electrical installations can cause serious damage. The incoming mains lead and its fuse must be dimensioned to suit the local power supply. The technical data shown on the rating plate applies.

# Connecting the mains cable

## General

A strain-relief device for the following cable cross-sections is fitted to the power source:

Power source	Cable cross-section	
	Canada / US	Europe
TSt 2500c / TSt 2700c	AWG 14 to AWG 6 *)	4G2.5
TSt 3500c	AWG 12 *)	4G2.5

\*) Canada / US cable type: Extra-hard usage

Strain-relief devices for other cable cross-sections must be designed accordingly.

## Stipulated mains cables and strain-relief devices

Power source	Mains voltage	Cable cross-section	
		Canada / US	Europe
TSt 2500c / TSt 2700c	1 x 230 / 240 V	AWG 14 (15 A) *)	3G2.5 (16 A)
TSt 2500c / TSt 2700c	1 x 240 V	AWG 12 (20 A) *)	-
TSt 2500c / TSt 2700c	1 x 240 V	AWG 12 (30 A) *)	-
TSt 2500c / TSt 2700c	3 x 200 V	AWG 12	4G2.5
TSt 2500c / TSt 2700c	3 x 230 / 240 V	AWG 14	4G2.5
TSt 2500c / TSt 2700c	3 x 380 / 400 V	AWG 14 *)	4G2.5
	3 x 460 V	AWG 14 *)	4G2.5
TSt 3500c	3 x 380 / 400 V	AWG 12 *)	4G2.5
	3 x 460 V	AWG 12 *)	4G2.5

\*) Canada / US cable type: Extra-hard usage

The item numbers of the different cables can be found in the spare parts list.

## American Wire Gauge

## Connecting the mains cable

If no mains cable is connected, a mains cable that is suitable for the connection voltage must be fitted before commissioning.



**CAUTION!** If no ferrules are used, there is a risk of injury and damage from short circuits between the phase conductors or between the phase conductors and the PE conductor. Fit ferrules to all phase conductors and the PE conductor of the stripped mains cable.

The ground conductor should be approx. 10 - 15 mm (0.4 - 0.6 in.) longer than the phase conductors.

An illustration of the mains cable connection can be found in the following sections for fitting the strain-relief device. To connect the mains cable, proceed as follows:

- 1** Remove the side panel from the device
- 2** Push the mains cable in far enough to make it possible to connect the ground conductor and the phase conductors to the block terminal properly.
- 3** Fit ferrules to the ground conductor and phase conductors

- 4 Connect the ground conductor and phase conductors to the block terminal
- 5 Use the strain-relief device to secure the mains cable
- 6 Fit the side panel of the device

**Fitting the strain-relief device, TSt 2500c MV / TSt 2700c, single-phase operation**

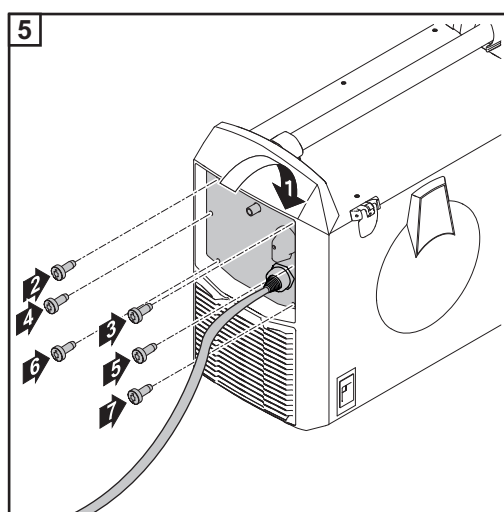
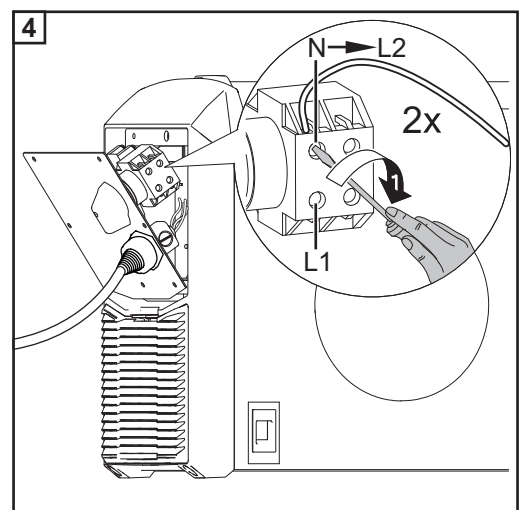
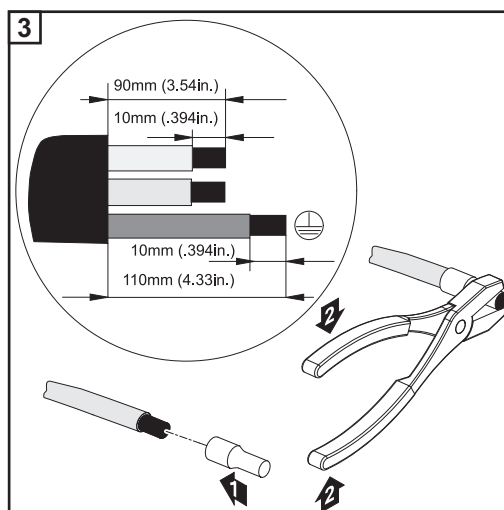
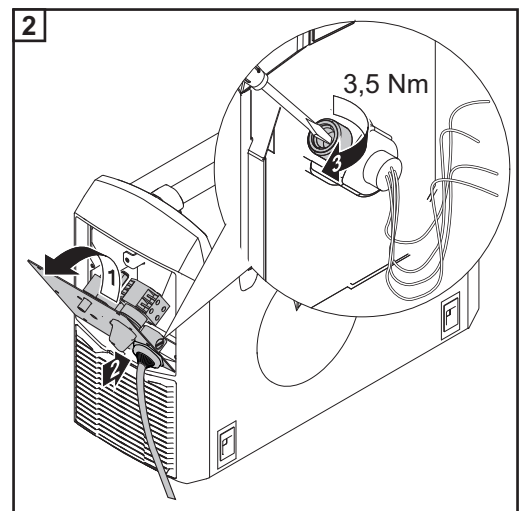
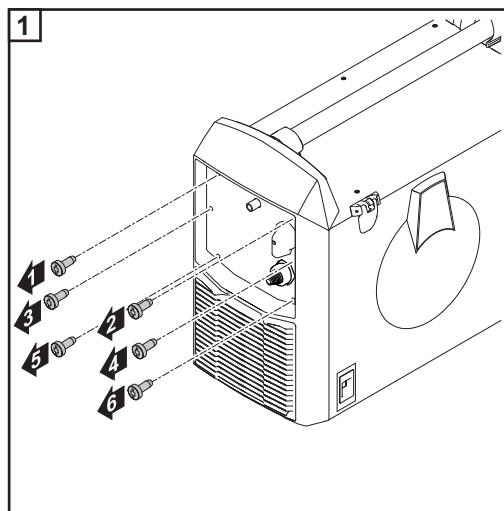

**IMPORTANT!** Tie the phase conductors near the strain-relief device using cable ties.

**Fitting the strain-relief device, TSt 2500c / TSt 2700c**

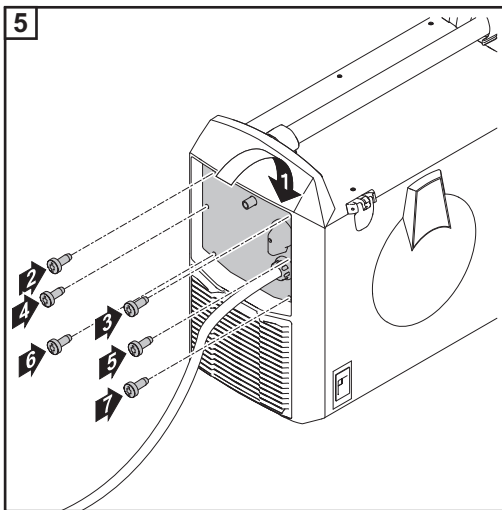
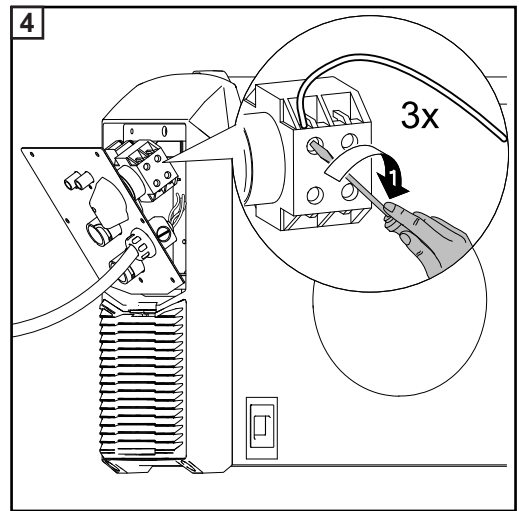
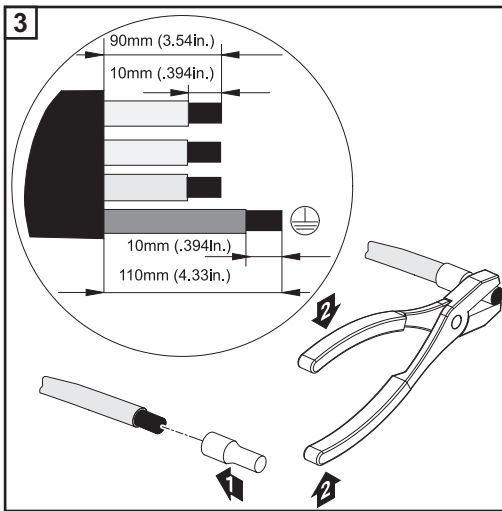
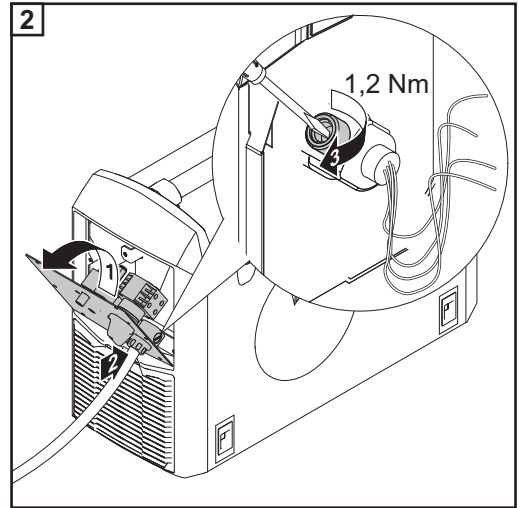
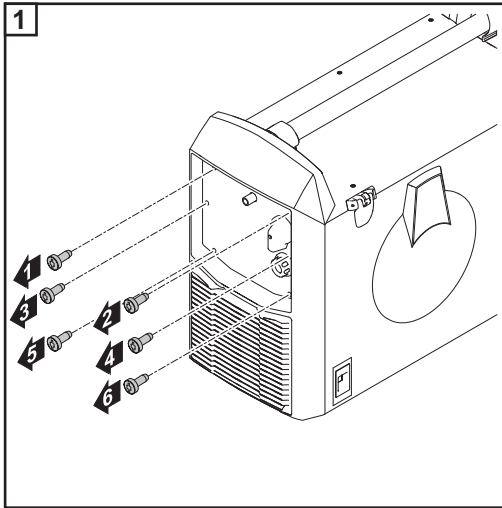

**IMPORTANT!** Tie the phase conductors near the strain-relief device using cable ties.

Fitting the strain-relief device, TSt 2500c MV / TSt 2700c MV

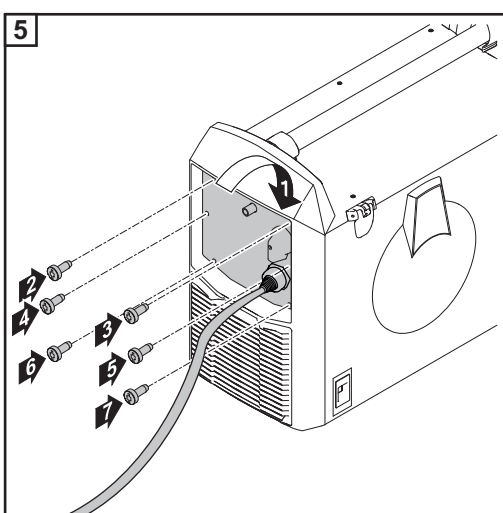
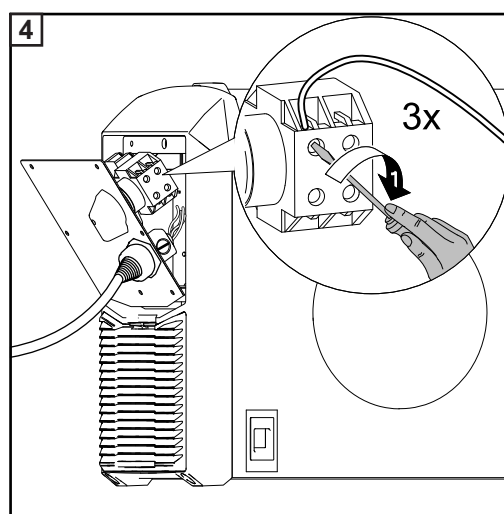
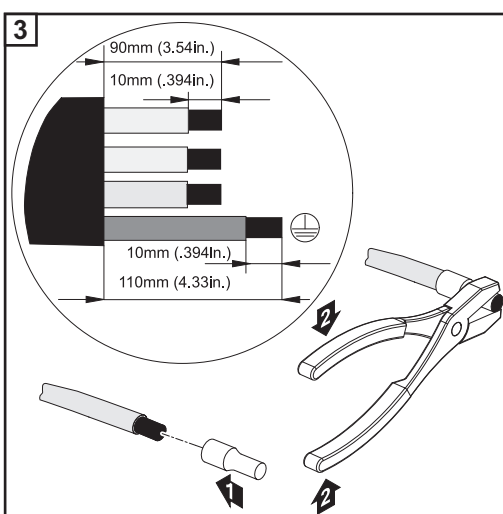
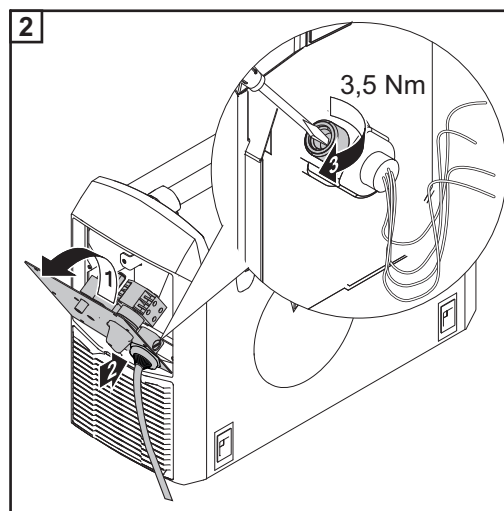
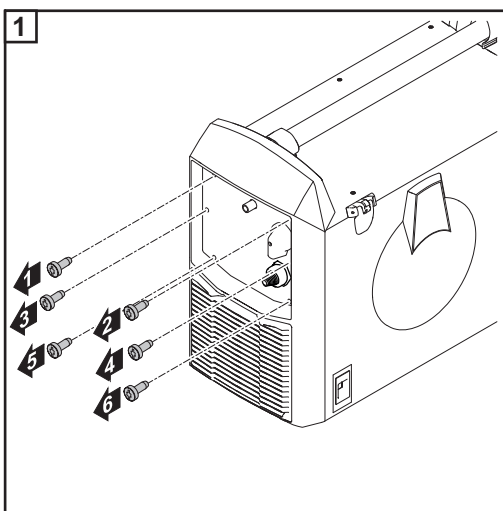

**IMPORTANT!** Tie the phase conductors near the strain-relief device using cable ties.

**Fitting the strain-relief device, TSt 3500c**

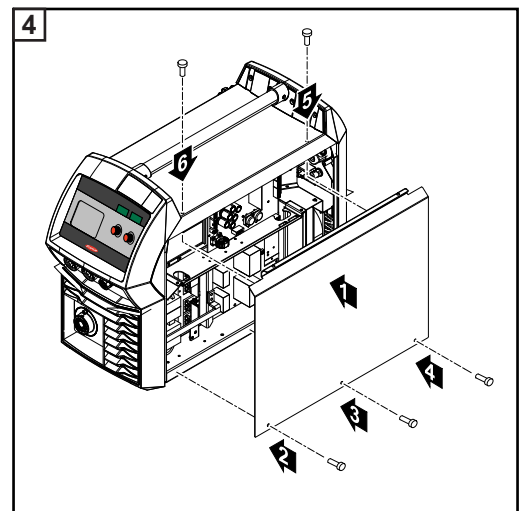
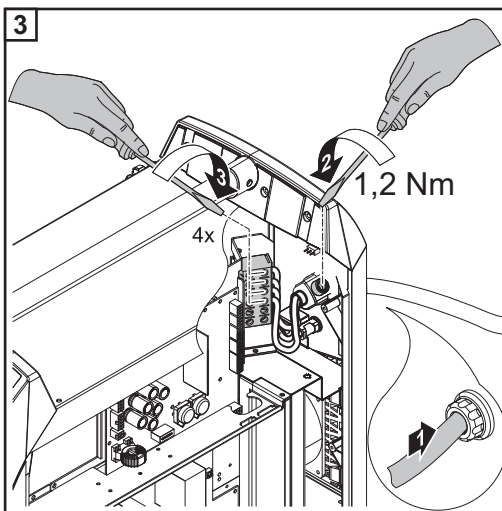
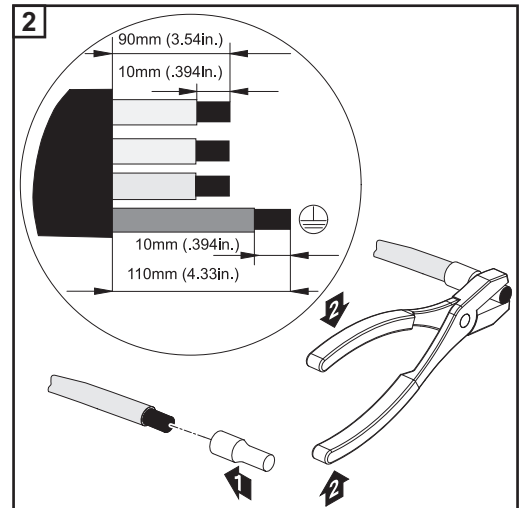
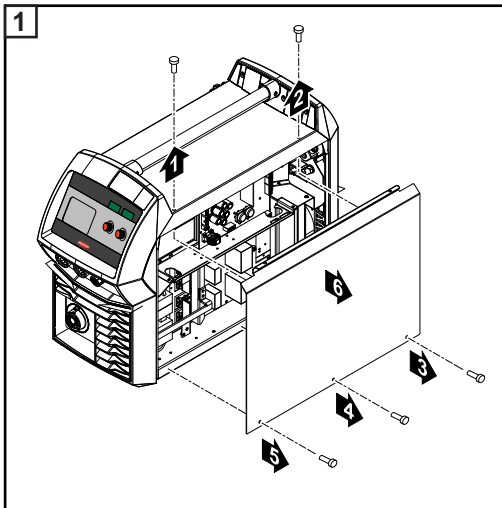

**IMPORTANT!** Tie the phase conductors near the luster terminal using cable ties.

**Fitting the Canada / U S strain-relief device, TSt 3500c**

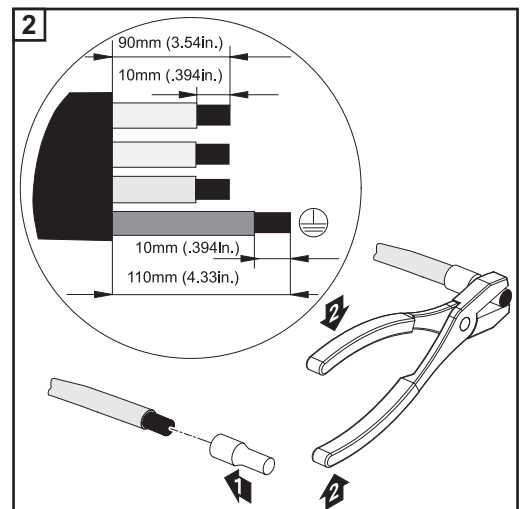
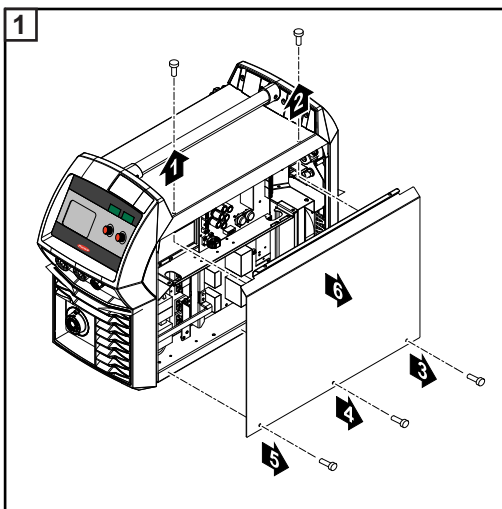



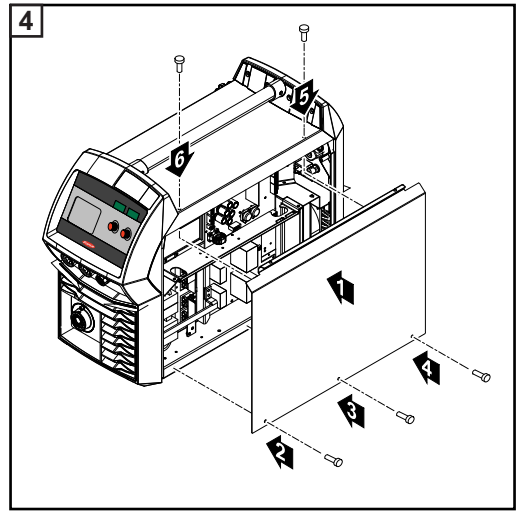
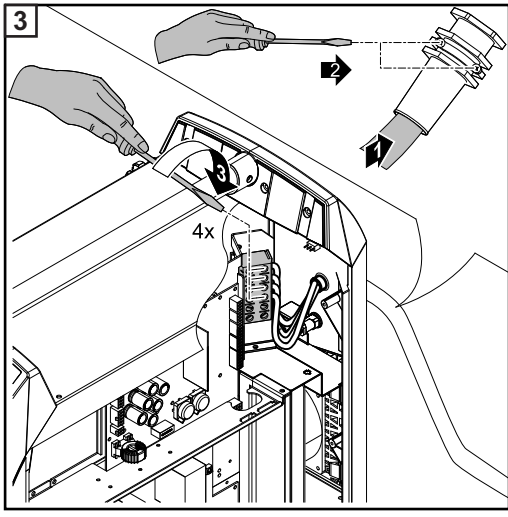

**IMPORTANT!** Tie the phase conductors near the luster terminal using cable ties.

# Generator-powered operation

---

## Generator-powered operation

The power source is generator-compatible.

The maximum apparent power  $S_{1\max}$  of the power source must be known in order to select the correct generator output.

The maximum apparent power  $S_{1\max}$  of the power source is calculated as follows:

3-phase devices:

$$S_{1\max} = I_{1\max} \times U_1 \times \sqrt{3}$$

Single-phase devices:

$$S_{1\max} = I_{1\max} \times U_1$$

See device rating plate or technical data for  $I_{1\max}$  and  $U_1$  values

The generator apparent power  $S_{\text{GEN}}$  needed is calculated using the following rule of thumb:

$$S_{\text{GEN}} = S_{1\max} \times 1.35$$

A smaller generator may be used when not welding at full power.

**IMPORTANT!** The generator apparent power  $S_{\text{GEN}}$  must always be higher than the maximum apparent power  $S_{1\max}$  of the power source.

When using single-phase devices with a 3-phase generator, note that the specified generator apparent power is often only available as a whole across all three phases of the generator. If necessary, obtain further information on the single-phase power of the generator from the generator manufacturer.



**NOTE!** The voltage delivered by the generator must never exceed the upper or lower limits of the mains voltage tolerance range. Details of the mains voltage tolerance can be found in the "Technical data" section.

# Single-phase operation

## Single-phase operation

As an alternative to three-phase operation, the multivoltage variant (MV) of the power source enables a welding operation with limited power or duration from just a single-phase supply. The maximum possible welding power is limited due to the dimensioning of the mains fuse protection, upon which the safety cut-out of the power source is dependant.

If the mains cable has a 20 A or 30 A fuse, the FUS parameter may be changed to 20 A or 30 A. Welding with a higher maximum power or for longer periods is therefore possible. The FUS parameter is in the level 2 Setup menu and can be set for a single-phase supply as well as to a US setting (SEt parameter to US).

In order to use the power source in single-phase operation, the following prerequisites must be fulfilled:

- Correct single-phase power source supply in accordance with the chapter "Installation and commissioning," section "Connecting the mains cable" - "Fitting the strain-relief device, single-phase operation."

The following table shows which mains voltages and fuse values limit the welding current in single-phase operation:

Mains voltage	Fuse value	Welding current limitation
230 V	10 A	MIG/MAG welding: max. 170 A; 100 A at 100%* MMA welding: max. 140 A; 100 A at 100%*
230 V	13 A	MIG/MAG welding: max. 160 A; 150 A at 100%* MMA welding: max. 140 A; 120 A at 100%*
230 V	16 A	MIG/MAG welding: max. 180 A; 145 A at 100%* MMA welding: max. 150 A; 130 A at 100%*
240 V	15 A	MIG/MAG welding: max. 180 A; 145 A at 100%* MMA welding: max. 150 A; 125 A at 100%*
240 V	20 A	MIG/MAG welding: max. 200 A; 160 A at 100%* MMA welding: max. 180 A; 140 A at 100%*
240 V	30 A	MIG/MAG welding: max. 220 A; 175 A at 100%* MMA welding: max. 180 A; 140 A at 100%*

\* The 100% values relate to welding with no time limits and without cooling breaks

The welding current data applies at an ambient temperature of 40°C (104°F).

At a mains voltage of 240 V and a fuse value of 30 A the maximum value of 220 A for the MIG/MAG welding for instance is possible at a duty cycle of 40 %.

In single-phase operation a safety cut-out function prevents a triggering of the fuse at higher welding power values. The safety cut-out function is active at fuse values of 15 A, 16 A and 20 A and determines the possible welding time, without triggering of the fuse. If a cut-out of the welding current results due to exceeding the pre-calculated welding time, the service code „toF“ is displayed. In addition to the readout „toF“ from now on a countdown runs for displaying the remaining waiting time, until the welding readiness is restored. Then the message disappears and the power source is operational again.

At a fuse value of 30 A the temperature monitoring of the power source ensures the timely shutdown of the welding current, yet before the fuse triggers. This results in the display of the service codes „to1“ to „to7“. Detailed information concerning the service codes „to1“ to „to7“ is located in chapter „Troubleshooting and maintenance, section „Displayed service codes“. If there is no defect or soiling of the cooling components, here the power source is also ready for welding again after an adequate welding break.

**Explanation of the term „duty cycle“ in single-phase operation**

For single-phase operation duty cycle values are given in the chapter „Technical data“, depending on the existing fuse value and the welding current. The percentage rates of this duty cycle values indeed relate as well to the 10-minute cycle, as explained in chapter „Technical data“ for the general duty cycle, however the cooling phase of the fuse is rated at only approximately 60 s. Thereafter, the power source is already operational again.

For reasons of technical standards the duty cycle in single-phase operation is only given for the time until the cut-out within the first welding cycle takes place. If the reference to the 10 minute cycle would also persist with regard to the cooling phase, which is usually valid for specifying the duty cycle, in practice longer welding phases than specified would be possible. You see that the specification relates to cooling phases of only approximately 60 s, after which the power source is already operational again.

The example given in the following shows the standard compliant welding and break cycles, at a welding current of 180 A and a duty cycle of 15 %.

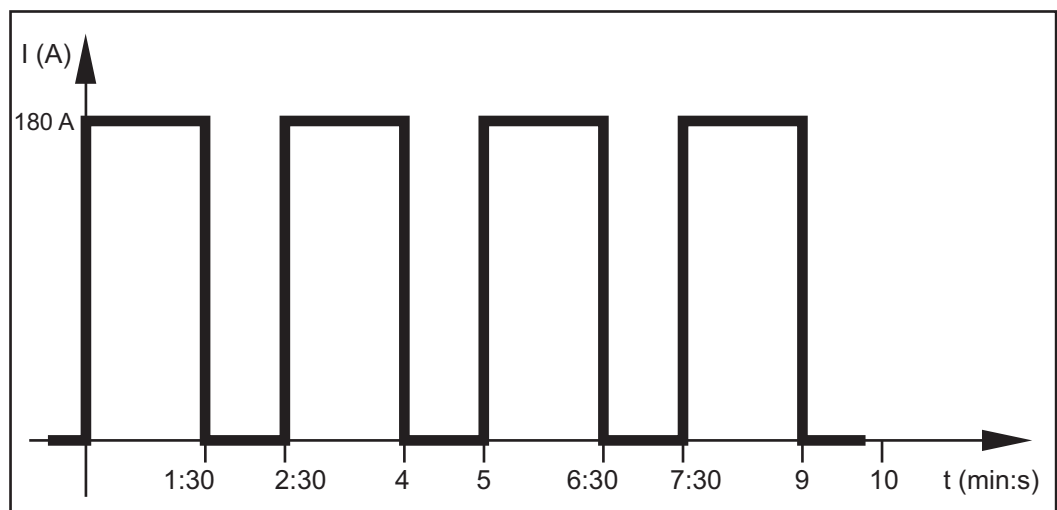

**Welding time in single-phase operation**

The following diagram shows the welding time, which is possible according to the technical standards, depending on the given fuse value and the welding current.

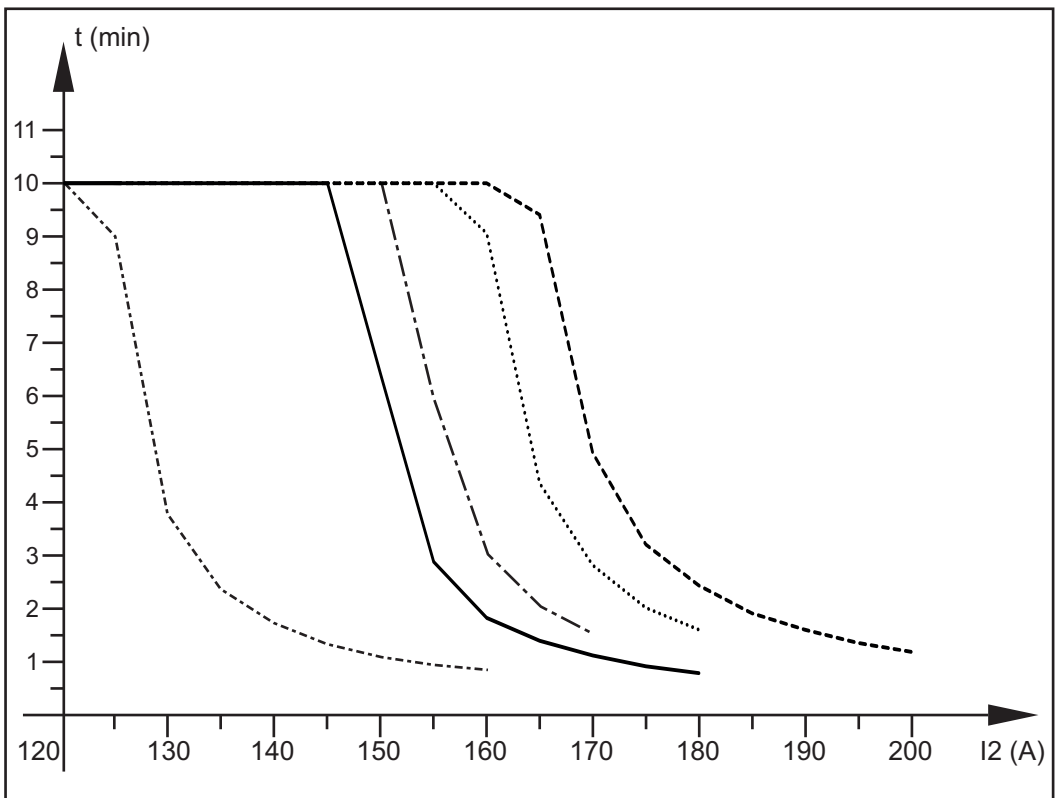

**Legend**

- Mains fuse protection 10 A
- Mains fuse protection 13 A
- - - Mains fuse protection 15 A
- ..... Mains fuse protection 16 A
- . - . Mains fuse protection 20 A

# Fitting/connecting the system components

## Information on system components

The steps and activities described below include references to various system components, such as

- Trolley
- Cooling units (TSt 3500c only)
- Welding torches, etc.

For more detailed information about installing and connecting the system components, please refer to the appropriate operating instructions.

## Mounting on the trolley



**WARNING!** Work that is carried out incorrectly can cause serious injury and damage. The following activities must only be carried out by trained and qualified personnel. All instructions in the section headed "Safety rules" must be observed.

The following diagram shows an overview of how the individual system components are put together.

For detailed information about the individual steps, please refer to the corresponding operating instructions for the system components.

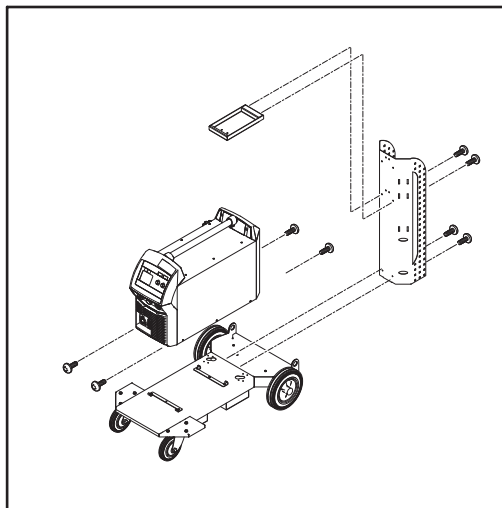

TSt 2500c / TSt 2700c

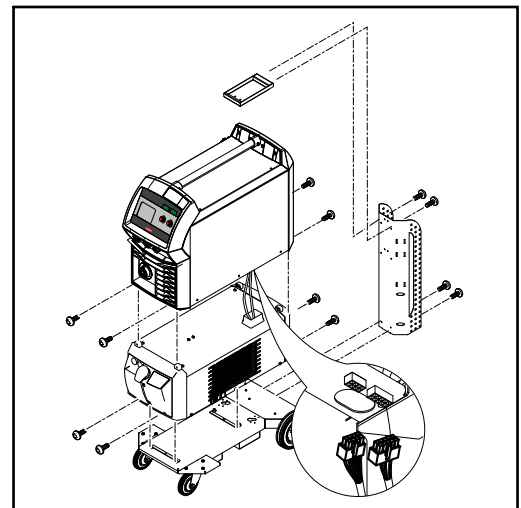

TSt 3500c

## Connecting the gas cylinder



**WARNING!** If gas cylinders topple over, there is a risk of very serious injury and damage. When using gas cylinders

- place them on a solid, level surface in such a way that they remain stable
- secure the gas cylinders to prevent them from falling over
- fit the optional wirefeeder holder

Follow the gas cylinder manufacturer's safety rules.

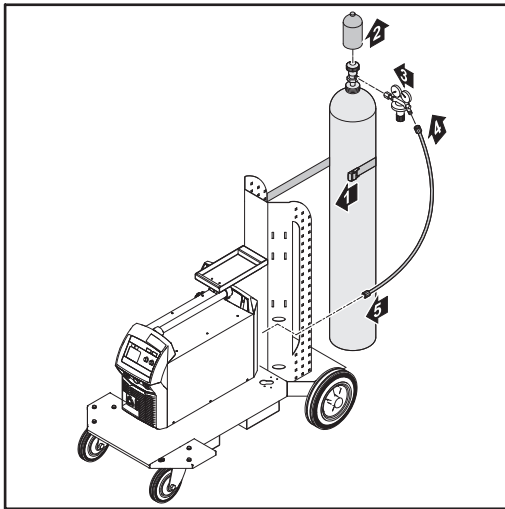

TSt 2500c / TSt 2700c

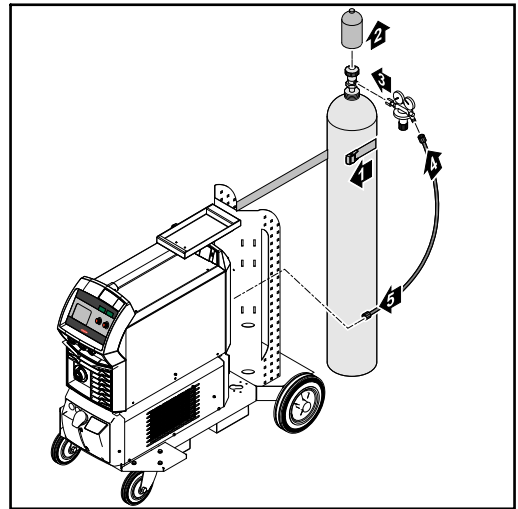

TSt 3500c

- 1 Secure the gas cylinder with a belt
- 2 Briefly open the gas cylinder valve to remove any dust or dirt
- 3 Check the seal on the pressure regulator



**NOTE!** US devices (TSt 3500c only) are supplied with an adapter for the gas hose:

- Seal male thread spacers on the gas solenoid valve using suitable means before screwing on the adapter.
- Test the adapter to ensure that it is gas-tight.

**Connecting a MIG/MAG welding torch**



**NOTE!** When connecting the welding torch, check that

- all connections are connected properly
- all cables, leads and hosepacks are undamaged and correctly insulated.

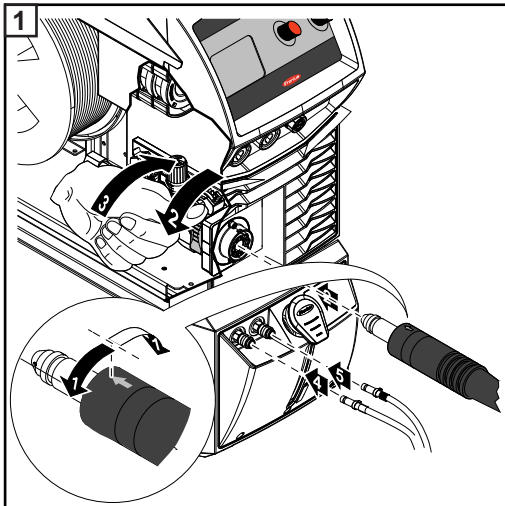

**Establishing a ground (earth) connection**

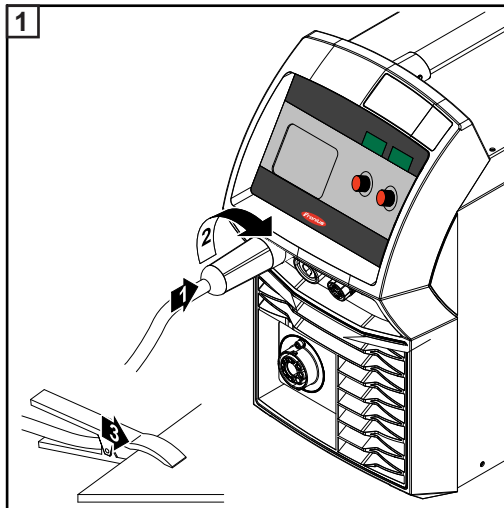

**Inserting/replacing feed rollers**

**CAUTION!** Risk of injury if the feed roller holders fly upwards. When unlocking the lever, keep fingers away from the area to the left and right of the lever.

In order to achieve optimum wire electrode feed, the feed rollers must be suitable for the diameter and alloy of the wire being welded.

An overview of the available feed rollers can be found in the spare parts lists.

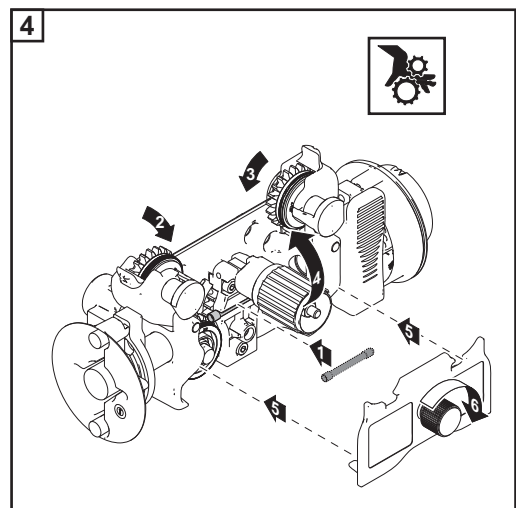
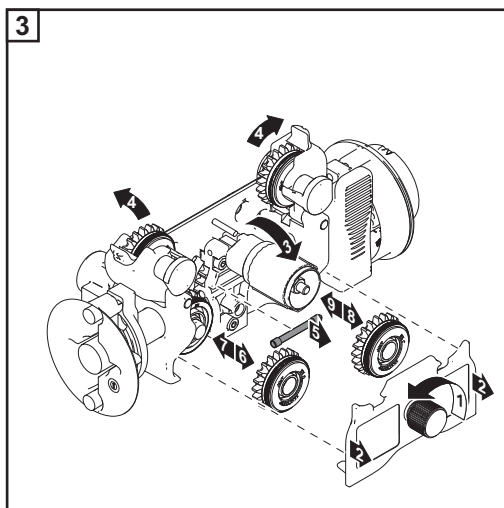
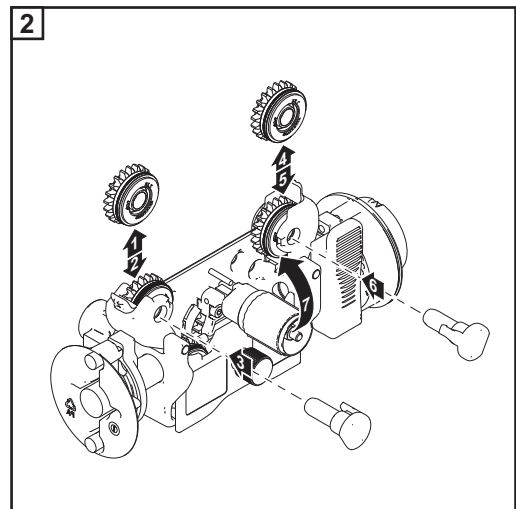
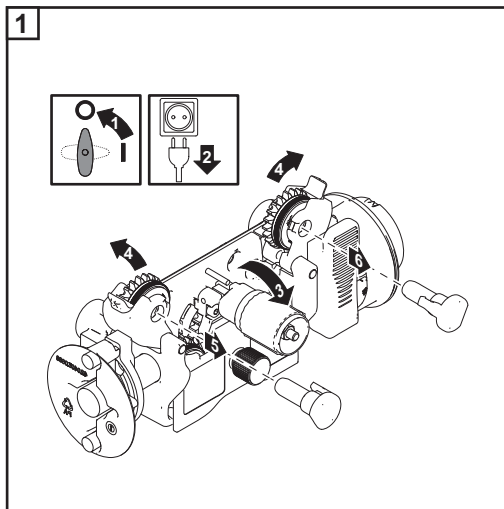





### Inserting the wire-spool/basket-type spool

 **CAUTION!** Risk of injury from springiness of spooled wire electrode. When inserting the wirepool / basket-type spool, hold the end of the wire electrode firmly to avoid injuries caused by the wire electrode springing back.

 **CAUTION!** Risk of injury from falling wirepool/basket-type spool. Make sure that the wirepool or basket-type spool with basket-type spool adapter is fitted securely to the wirepool holder.

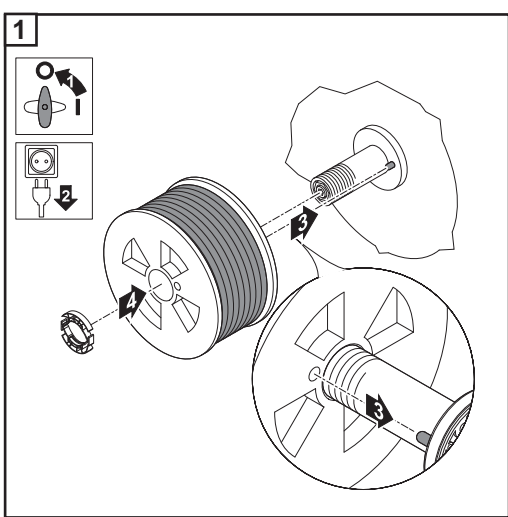
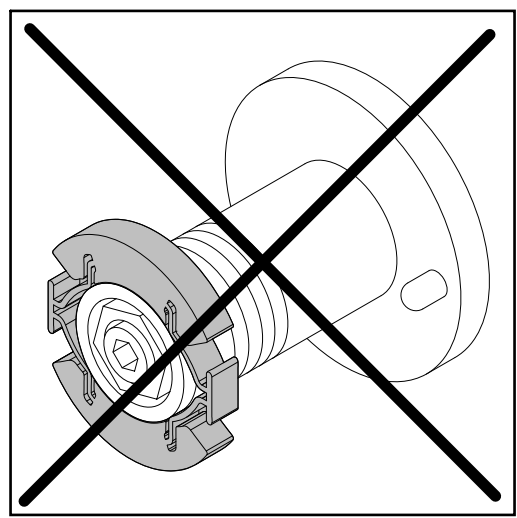
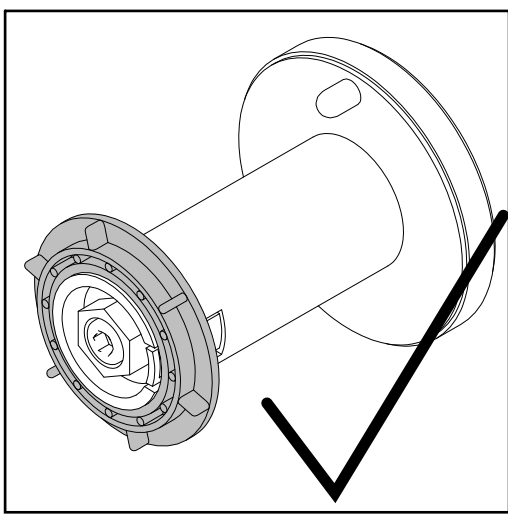
 **CAUTION!** Risk of injury and material damage if the wirepool/basket-type spool topples over because the locking ring has been placed the wrong way round. Always place the locking ring as shown in the diagram on the left.



 **NOTE!** When working with basket-type spools, only use the basket-type spool adapter included in the scope of supply.

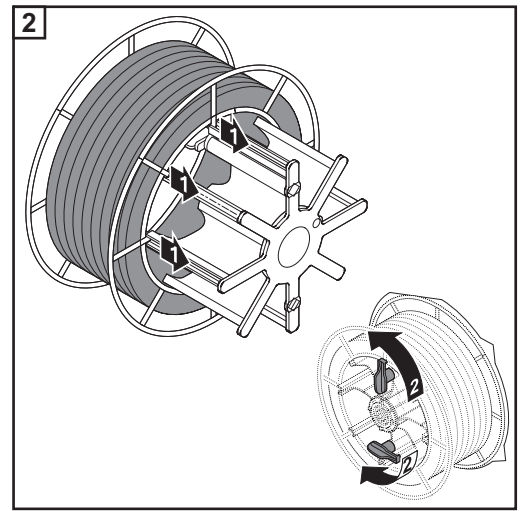
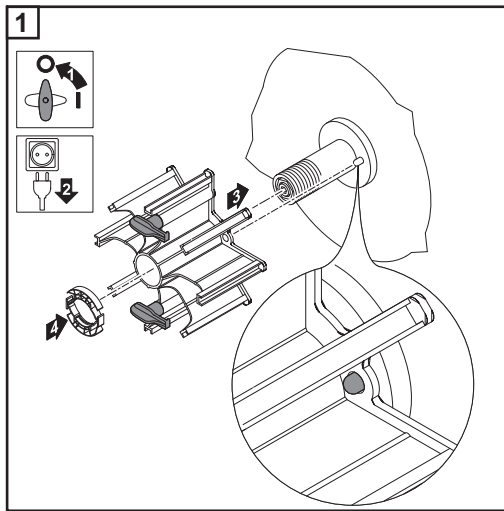

**Feeding in the wire electrode**

**CAUTION!** Risk of injury from springiness of spooled wire electrode. When inserting the wire electrode into the 4-roller drive, hold the end of the wire electrode firmly to avoid injuries caused by the wire springing back.

**CAUTION!** Risk of damage to the welding torch from sharp end of wire electrode. Deburr the end of the wire electrode well before feeding in.

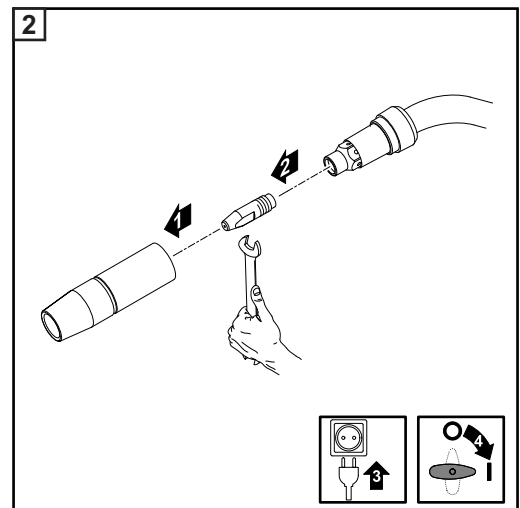
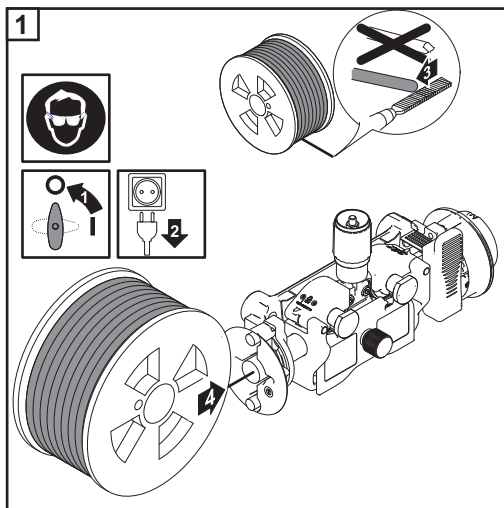

**CAUTION!** Risk of injury from wire electrode emerging at speed. When pressing the "Wire threading" button or the torch trigger, keep the welding torch away from your face and body, and wear suitable protective goggles.

**IMPORTANT!** To facilitate wire threading, the following sequences are possible when the "Wire threading" button is pressed and held down.

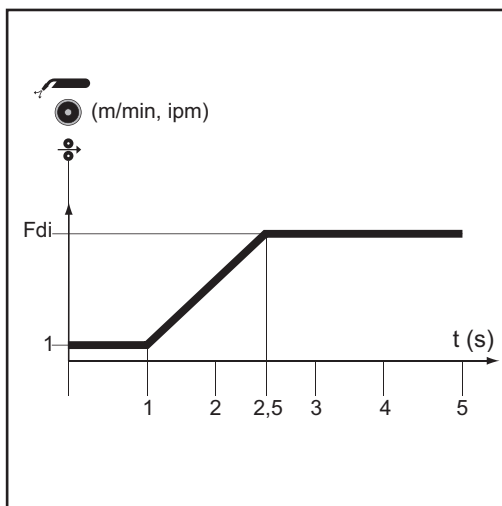

- Hold the button for up to **one second** ... the wire feed speed stays at 1 m/min or 39.37 ipm for the first second.
- Hold the button for up to **2.5 seconds** ... after one second, the wire feed speed increases over the next 1.5 seconds.
- Hold the button for **more than 2.5 seconds** ... after 2.5 seconds, the wire is fed at a constant rate equal to the wire feed speed set for the Fdi welding parameter.

If you release the "Wire threading" button and press it again before one second has elapsed, the sequence starts again from the beginning. This makes it possible to continuously position the wire at a low wire feed speed of 1 m/min or 39.37 ipm where necessary.

If there is no "Wire threading" / "Gas-test" button, the **torch trigger** can be used in the usual way. Before using the torch trigger for wire threading, proceed as follows:

- 1** Press the "Mode" button to select 2-step mode
- 2** Set the "lto" parameter to "Off" in the Setup menu



**CAUTION!** Risk of injury and damage from electric shock and from the wire electrode emerging from the torch. When pressing the torch trigger

- keep the welding torch away from your face and body
- wear suitable protective goggles
- do not point the welding torch at people
- make sure that the wire electrode does not touch any conductive or earthed parts (e.g. Housing etc.)

**IMPORTANT!** If the **torch trigger** is pressed instead of the "Wire threading"/"Gas-test" button, the welding wire runs at the feeder creep speed (depending on the welding program) for the first 3 seconds. After these 3 seconds, wirefeeding is briefly interrupted.

The welding system detects that the welding process should not start, but that the wire is to be fed in. At the same time, the gas solenoid valve closes, and the welding voltage on the wire electrode is switched off.

If the torch trigger is kept pressed, wire feeding restarts immediately without shielding gas and welding voltage, and the process continues as described above.

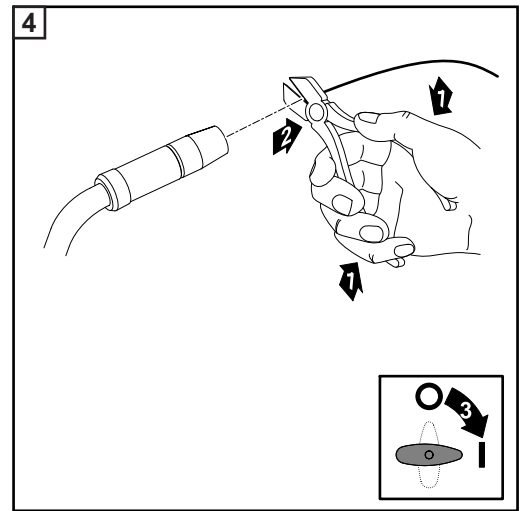
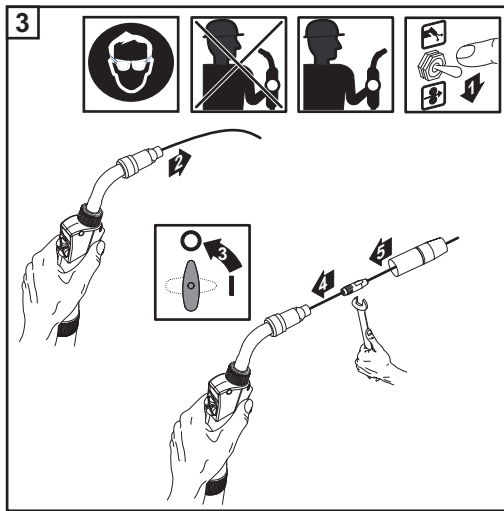

**Setting the contact pressure**



**NOTE!** Set the contact pressure in such a way that the wire electrode is not deformed but nevertheless ensures proper wirefeed.

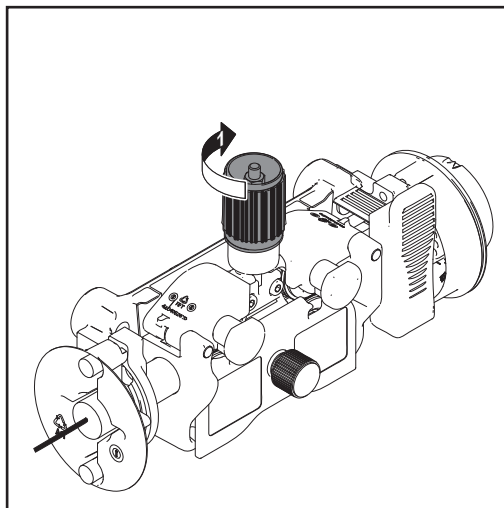

Standard values	U-grooved rollers
Steel	4 - 5
CrNi	4 - 5
Tubular cored electrodes	2 - 3

**Adjusting the brake**



**NOTE!** After releasing the torch trigger the wire spool must stop unreeling. If it continues unreeling, readjust the brake.

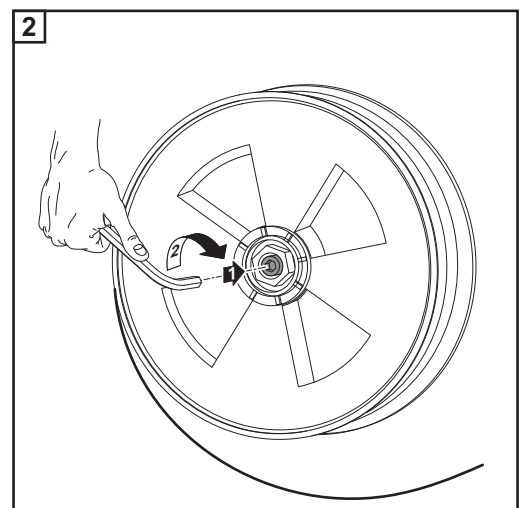
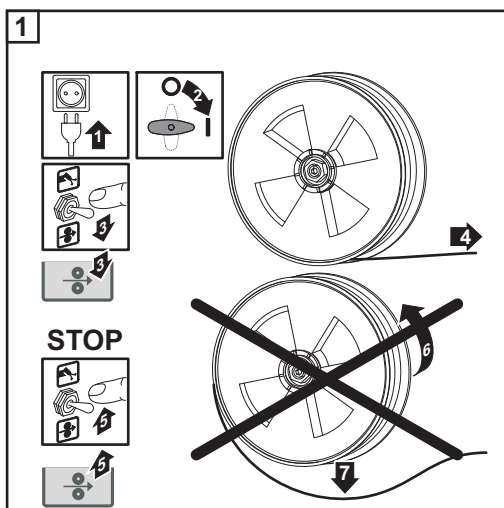

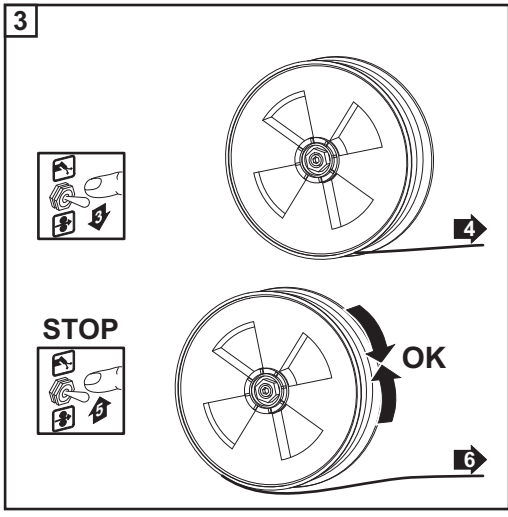

**Design of the brake**

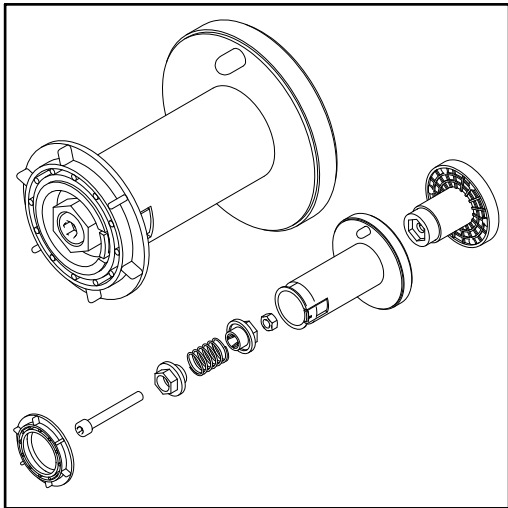

**!** **WARNING!** Fitting the equipment incorrectly can cause serious injury and damage.

- Do not dismantle the brake.
- Maintenance and servicing of brakes is to be carried out by trained, qualified personnel only.

The brake is only available as a complete unit.  
This illustration is for information purposes only.

# Start-up

---

## General



**WARNING!** Operating the equipment incorrectly can cause serious injury and damage. Do not use the functions described until you have thoroughly read and understood the following documents:

- these operating instructions
- all the operating instructions for the system components, especially the safety rules

The device is started up by pressing the torch trigger (for manual applications).

---

## Prerequisites

The following conditions must be satisfied before the device is started:

- Welding torch connected
  - Feed rollers inserted
  - Wirespool or basket-type spool with adapter inserted
  - Wire electrode fed in
  - Brake adjusted
  - Feed roller contact pressure set
  - All covers closed, all side panels in place, all protection devices intact and in their proper place
  - Where applicable, water connections connected
- 

## Commissioning

Before proceeding further as described in the "Welding mode" section, the following activities are required for the "MIG/MAG standard synergic welding" and "MIG/MAG standard manual welding" processes:

- 1 Plug in the mains plug
- 2 Turn the mains switch to position "I"

# **Welding**





# Power limitation

---

## Safety function

"Power limitation" is a safety function for MIG/MAG welding. This means that the power source can be operated at the power limit whilst maintaining process safety.

Wire feed speed is a determining parameter for welding power. If it is too high, the arc gets smaller and smaller and may be extinguished. In order to prevent this, the welding power is lowered.

 For the selected "MIG/MAG standard synergic welding" process, the symbol for the "Wire feed speed" parameter flashes as soon as the safety function trips. The flashing continues until the next welding start-up, or until the next parameter change.

If the "Wire feed speed" parameter is selected, the reduced value for wire feed speed is displayed.

# MIG/MAG modes

## General



**WARNING!** Operating the equipment incorrectly can cause serious injury and damage. Do not use the functions described until you have thoroughly read and understood the following documents:

- these operating instructions
- all the operating instructions for the system components, especially the safety rules

For details of the meaning, settings, setting range and units of the available welding parameters (e.g. gas pre-flow time), please refer to the "Set-up parameters" section.

## Symbols and their explanations

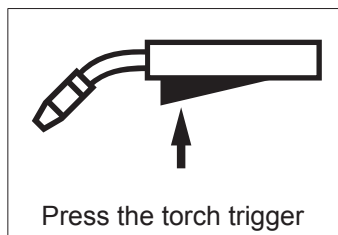

Press the torch trigger

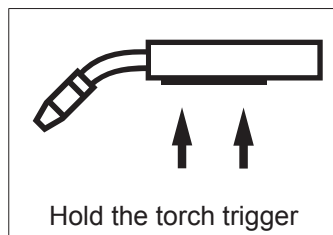

Hold the torch trigger

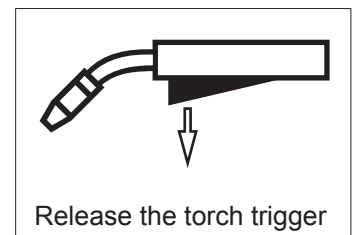

Release the torch trigger

### **GPr**

Gas pre-flow time

### **I-S**

Starting current

can be increased or decreased depending on the application

### **SL**

Slope: the starting current is continuously lowered as far as the welding current and the welding current as far as the final current

### **I**

Welding-current phase: uniform thermal input into the base material, whose temperature is raised by the advancing heat

### **I-E**

Final current

for filling the end-crater.

### **GPo**

Gas post-flow time

### **SPT**

Spot welding time / stitch welding time

### **SPb**

Stitch pause time

### 2-step mode

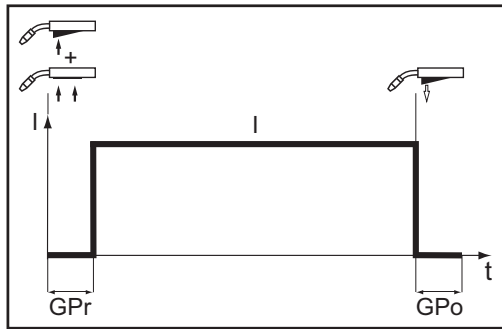

"2-step mode" is suitable for

- Tacking work
- Short weld seams

### 4-step mode

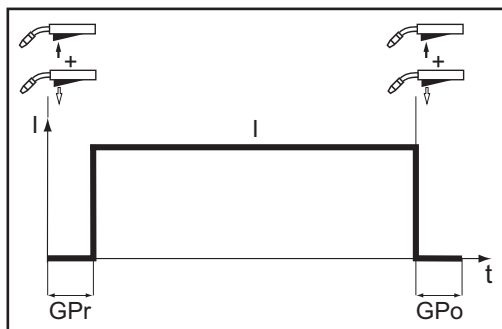

"4-step mode" is suitable for longer weld seams.

### Special 4-step mode

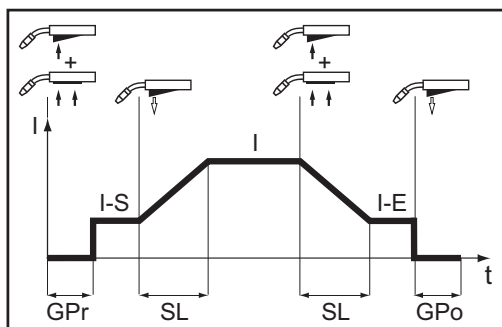

Special 4-step mode allows the starting and final current to be configured in addition to the advantages of 4-step mode.

### Spot welding

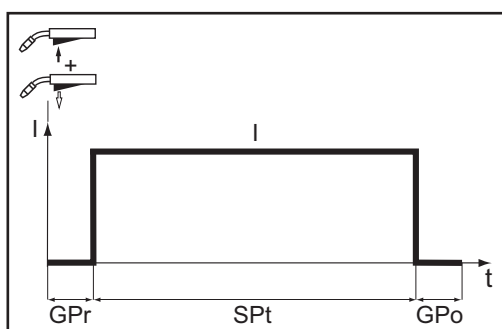

The "Spot welding" mode is suitable for welded joints on overlapped sheets.

---

**2-step stitch welding**

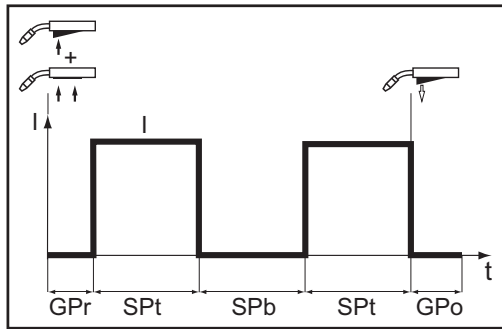

The "2-step stitch welding" mode is suitable for welding short weld seams on thin sheets, to prevent the weld seams from dropping through the base material.

---

**4-step stitch welding**

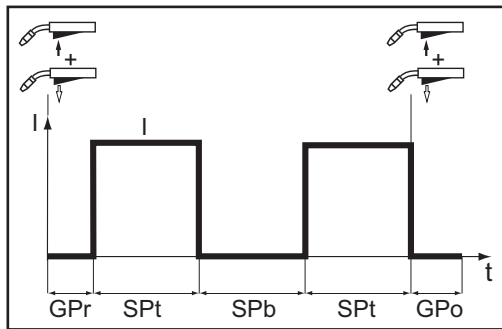

The "4-step stitch welding" mode is suitable for welding longer weld seams on thin sheets, to prevent the weld seams from dropping through the base material.

# MIG/MAG welding

---

## Safety



**WARNING!** Operating the equipment incorrectly can cause serious injury and damage. Do not use the functions described until you have thoroughly read and understood the following documents:

- these operating instructions
- all the operating instructions for the system components, especially the safety rules



**WARNING!** An electric shock can be fatal. If the power source is connected to the mains electricity supply during installation, there is a high risk of very serious injury and damage. Before carrying out any work on the device make sure that:

- the power source mains switch is in the "O" position
- the power source is unplugged from the mains

---





## Overview

MIG/MAG welding is composed of the following sections:





- MIG/MAG standard synergic welding
- MIG/MAG standard manual welding

# MIG/MAG standard synergic welding

## MIG/MAG standard synergic welding

- 1 Press the "Material" button to select the filler metal to be used.
- 2 Press the "Wire diameter" button to select the diameter of the wire electrode used.
- 3 Press the "Shielding gas" button to select the shielding gas to be used.  
The assignment of the SP position is in the welding program tables in the appendix.
- 4 Press the "Process" button to select the desired welding process:
  -  MIG/MAG standard synergic welding
- 5 Press the "Mode" button to select the desired MIG/MAG mode:
  -  2-step mode
  -  4-step mode
  -  Special 4-step mode

**IMPORTANT!** Under certain circumstances, it may not be possible to change welding parameters that have been set on the control panel of a system component (TR 2000 or TR 3000 remote control) on the control panel of the power source.

- 6 Use the "Parameter selection" buttons to select the welding parameters to be used to specify the welding power:
  -  Sheet thickness
  -  Welding current
  -  Wire speed
  -  Welding voltage
- 7 Use the appropriate adjusting dial to set the relevant welding parameters.  
The welding parameter values are shown in the digital display located above them.

All welding parameter set values remain stored until the next time they are changed. This applies even if the power source is switched off and on again. To display the actual welding current during welding, select the welding current parameter.

- 8 Open the gas cylinder valve
- 9 Setting the shielding gas flow rate:
  - Tap the "Gas-test" button
  - Turn the adjusting screw on the underside of the pressure regulator until the pressure gauge shows the required gas flow rate
  - Tap the "Gas-test" button again



**CAUTION!** Risk of injury and damage from electric shock and from the wire electrode emerging from the torch. When pressing the torch trigger

- keep the welding torch away from your face and body
- wear suitable protective goggles
- do not point the welding torch at people
- make sure that the wire electrode does not touch any conductive or earthed parts (e.g. housing)

- 10 Press the torch trigger and start welding

## Corrections during welding

To obtain the best possible welding results, the arc length correction and dynamic welding parameters will sometimes need to be corrected.

- 1 Press the "Parameter selection" buttons to select the parameters you wish to correct.
- 2 Use the adjusting dials to set the selected welding parameters to the required values.  
Welding parameter values are shown in the indicators located above them.

# MIG/MAG standard manual welding

---

## General

The MIG/MAG standard manual welding process is a MIG/MAG welding process with no synergic function.

Changing one parameter does not result in any automatic adjustments to the other parameters. All of the variable parameters must therefore be adjusted individually, as dictated by the welding process in question.

---

## Available parameters

The following parameters are available in MIG/MAG manual welding:

---

### Wire feed speed

1 m/min (39.37 ipm.) - maximum wire feed speed, e.g. 25 m/min (984.25 ipm.)

---

### Welding voltage

TSt 2500c: 14.4 - 34.5 V

TSt 2700c: 14.4 - 34.9 V

TSt 3500c: 14.5 - 38.5 V

---

### Dynamic

... for influencing the short-circuiting dynamic at the moment of droplet transfer

---

### Welding current

only for displaying the actual value

---

---

## MIG/MAG standard manual welding

**1** Press the "Process" button to select the desired welding process:

 MIG/MAG standard manual welding

**2** Press the "Mode" button to select the desired MIG/MAG mode:

 2-step mode

 4-step mode

In MIG/MAG standard manual welding, special 4-step mode corresponds to conventional 4-step mode.

**IMPORTANT!** Under certain circumstances, it may not be possible to change welding parameters that have been set on the control panel of a system component (TR 2000 or TR 3000 remote control) on the control panel of the wirefeeder.

**3** Press the "Parameter selection" button to select the wire speed parameter

**4** Use the adjusting dial to set the desired value for the wire speed

**5** Press the "Parameter selection" button to select the welding voltage parameter

**6** Use the adjusting dial to set the desired value for the welding voltage

The welding parameter values are shown in the digital display located above them.

All welding parameter set values remain stored until the next time they are changed. This applies even if the power source is switched off and on again. To display the actual welding current during welding, select the welding current parameter.



To display the actual welding current during welding:

- Press the "Parameter selection" button to select the welding current parameter
- The actual welding current is shown on the digital display during welding.

**7** Open the gas cylinder valve

**8** Setting the shielding gas flow rate:

- Tap the "Gas-test" button
- Turn the adjusting screw on the underside of the pressure regulator until the pressure gauge shows the required gas flow rate
- Tap the "Gas-test" button again



**CAUTION!** Risk of injury and damage from electric shock and from the wire electrode emerging from the torch. When pressing the torch trigger

- keep the welding torch away from your face and body
- wear suitable protective goggles
- do not point the welding torch at people
- make sure that the wire electrode does not touch any conductive or earthed parts (e.g. housing)

**9** Press the torch trigger and start welding

---

### Corrections during welding

To obtain the best possible welding results, the arc-force dynamic parameter will sometimes need to be adjusted.

**1** Press the "Parameter selection" button to select the arc-force dynamic parameter

**2** Use the adjusting dial to set the desired arc-force dynamic value

The welding parameter value is shown in the digital display located above it.

# MMA welding

---

## Safety



**WARNING!** Operating the equipment incorrectly can cause serious injury and damage. Do not use the functions described until you have thoroughly read and understood the following documents:

- these operating instructions
- all the operating instructions for the system components, especially the safety rules



**WARNING!** An electric shock can be fatal. If the machine is plugged into the mains electricity supply during installation, there is a high risk of very serious injury and damage. Do not carry out any work on the device unless

- the mains switch is in the "O" position,
- the device is unplugged from the mains.

---

## Preparation

- 1 Move the mains switch to the "O" position
- 2 Disconnect the mains plug

**IMPORTANT!** Check the rod electrode packaging to determine whether the rod electrodes are for (+) or (-) welding.

- 3 Plug the grounding (earthing) cable into the (-) or (+) current socket (depending upon which type of electrode is to be used) and latch it by turning it clockwise
- 4 Use the other end of the grounding (earthing) cable to establish a connection to the workpiece
- 5 Plug the electrode holder cable bayonet plug into the free current socket with the opposite polarity, according to the type of electrode, and turn it clockwise to latch it in place
- 6 Plug in the mains plug

---

## MMA welding



**CAUTION!** Risk of injury and damage from electric shock. As soon as the mains switch is in the "I" position, the rod electrode in the electrode holder is live. Make sure that the rod electrode does not touch any persons or electrically conducting or earthed parts (e.g. the housing, etc.).

- 1 Move the mains switch to the "I" position: all the indicators on the control panel will briefly light up
- 2 Press the "Process" button to select the MMA welding process:



The welding voltage is connected to the welding socket with a 3-second time lag.

**IMPORTANT!** Under certain circumstances, welding parameters that have been set on a system component control panel (TR 2000 and TR 3000) may not be changed on the control panel of the power source.

- 3 Press the "Parameter selection" button to select the amperage parameter.
- 4 Use the adjusting dial to set the desired amperage.

The amperage value is displayed in the left-hand digital display.

All welding parameter set values remain stored until the next time they are changed. This applies even if the power source is switched off and on again in the meantime.

**5** Start welding

To display the actual welding current during welding:

- Press the "Parameter selection" button to select the welding current parameter
- The actual welding current is shown on the digital display during welding.

**Corrections during welding**

To obtain the best possible welding results, the arc-force dynamic parameter will sometimes need to be adjusted.

- 1** Press the "Parameter selection" button to select the arc-force dynamic parameter
- 2** Use the adjusting dial to set the desired arc-force dynamic value  
The welding parameter value is shown in the digital display located above it.

**HotStart function**

To obtain optimum welding results, it will sometimes be necessary to adjust the HotStart function.

**Advantages**

- Improved ignition, even when using electrodes with poor ignition properties
- Better fusion of the base material during the start-up phase, meaning fewer cold-shut defects
- Largely prevents slag inclusions

For details on setting the available welding parameters, please refer to "Setup parameters", "Setup menu - level 2".

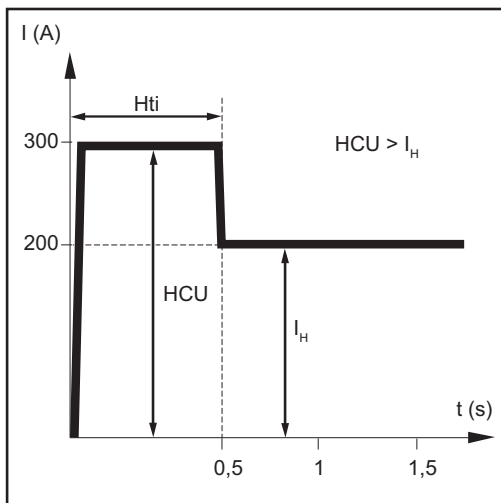

**Legend**

- Hti: Hot-current time, 0 - 2 s, factory setting: 0.5 s
- HCU: HotStart-current, 100 - 200 %, factory setting 150 %
- $I_H$ : Main current = set welding current

**Function**

During the specified hot-current time (Hti), the welding current is increased to a certain value. This value (HCU) is higher than the selected welding current ( $I_H$ ).

**Anti-stick function**

As the arc becomes shorter, the welding voltage may drop so far that the rod electrode will tend to "stick". This may also cause "burn-out" of the rod electrode.

Electrode burn-out is prevented by activating the anti-stick function. If the rod electrode begins to stick, the power source immediately switches the welding current off. After the rod electrode has been detached from the workpiece, the welding operation can be continued without difficulty.

The anti-stick (Ast) function can be activated and deactivated in the Setup parameters in "Setup menu: level 2".

# Saving and retrieving operating points

---

## General

The "Save" buttons allow up to 5 operating points to be saved. Every operating point matches the settings on the control panel.

**IMPORTANT!** Setup parameters are not saved at this time.

---

## Saving operating points

**1** Press and hold one of the "Save" buttons to save the current settings on the control panel, e.g.:



- The left indicator displays "Pro"
- After a short time, the left indicator switches to the original value

**2** Release the "Save" button

---

## Retrieving operating points

**1** To retrieve saved settings, press the corresponding "Save" button briefly, e.g.:



- The control panel will show the saved settings
- 

## Deleting operating points

**1** Press and hold the relevant "Save" button to delete the memory content of that "Save" button, e.g.:



- The left indicator displays "Pro"
- After a short time, the left indicator switches to the original value

**2** Keep the "Save" button held down

- The left display shows "CLr".
- After a while, both displays show "---"

**3** Release the "Save" button

---

## Retrieving operating points on the Up/Down welding torch

One of the "Save" buttons on the control panel must be pressed to retrieve the saved settings using the Up/Down welding torch.

**1** Press one of the "Save" buttons on the control panel, e.g.:



- The control panel will show the saved settings

The "Save" buttons can now be selected using the buttons on the Up/Down welding torch. Vacant "Save" buttons are skipped.

In addition to the "Save" button number lighting up, a number is displayed directly on the Up/Down welding torch:

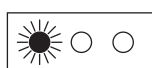

Number 1

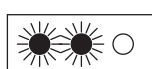

Number 2

---

	Number 3
	Number 4
	Number 5



# Setup settings









# Setup menu

**General remarks** The Setup menu provides simple access to expert knowledge in the power source and to additional functions. The Setup menu can be used to make simple adjustments of the parameters to suit the various job settings.





**Configuring the setup parameters** Configuring the setup parameters is described here with reference to the "MIG/MAG standard synergic welding" process. The procedure for changing other setup parameters is identical.

## Accessing the Setup menu



- 
1 Use the "Process" button to select the "MIG/MAG standard synergic welding" process
- 
2 Press and hold the "Mode" button
- 
3 Press the "Process" button
- 
4 Release the "Mode" and "Process" buttons

The control panel is now in the Setup menu for the "MIG/MAG standard synergic welding" process - the last setup parameter that was selected is displayed.

## Changing welding parameters

- 
5 Select the required setup parameter using the "Mode" and "Process" buttons or the left-hand adjusting dial
- 
- 
6 Change the value of the setup parameter using the "Parameter selection" buttons or the right-hand adjusting dial
- 

## Exiting the Setup menu

- 
7 Press and hold the "Mode" button
- 
8 Press the "Process" button
- 
9 Release the "Mode" and "Process" buttons

---

**Setup parameters  
for MIG/MAG  
standard manual  
welding**

"Min." and "max." are used for setting ranges that differ according to power source, welding program, etc.

---

**GPr Gas pre-flow time**  
Unit: s  
Setting range: 0 - 9.9  
Factory setting: 0.1

---

**GPo Gas post-flow time**  
Unit: s  
Setting range: 0 - 9.9  
Factory setting: 0.5

---

**Fdi Feeder inching speed**  
Unit: m/min (ipm)  
Setting range: 1 - max. (39.37 - max.)  
Factory setting: 10 (393.7)

---

**SL Slope (special 4-step mode only)**  
Unit: s  
Setting range: 0 - 9.9  
Factory setting: 0.1

---

**I-S I (current) - Starting - Starting current (special 4-step mode only)**  
Unit: % (of welding current)  
Setting range: 0 - 200  
Factory setting: 100

---

**I-E I (current) - End: Final current (special 4-step mode only)**  
Unit: % (of welding current)  
Setting range: 0 - 200  
Factory setting: 50

---

**t-S t (time) - Starting - Starting current duration (special 4-step mode only)**  
Unit: s  
Setting range: OFF, 0.1 - 9.9  
Factory setting: OFF

---

**t-S t (time) - End: Final current duration (special 4-step mode only)**  
Unit: s  
Setting range: OFF, 0.1 - 9.9  
Factory setting: OFF

---

**bbc burn-back time correction**  
Wire burn-back effect due to wire withdrawal at end of welding  
Unit: -  
Setting range: 0 - 20  
Factory setting: 0

---

**IGC Ignition current**  
Unit: A  
Setting range: 100 - 650  
Factory setting: 500

---

**Ito Ignition time-out - length of wire that is fed before the safety cut-out is triggered**  
Unit: mm (in.)

Setting range: OFF, 5 - 100 (OFF, 0.2 - 3.94)

Factory setting: OFF



**NOTE!** The "Ignition time-out" function (ito) is a safety function. The length of wire that is fed before the safety cut-out trips may differ from the preset wire length, particularly when the wire is being fed at high speeds.

---

**SPt Spot time - spot / stitch welding time**

Unit: s

Setting range: OFF, 0.1 - 5

Factory setting: OFF

---

**SPb Spot break - stitch pause time**

Unit: s

Setting range: OFF, 0.1 - 10 (in 0.1 s increments)

Factory setting: OFF

---

**FAC Factory - reset power source to factory settings**

Press and hold down one of the "Parameter selection" buttons for 2 s to restore the factory settings

- when "PrG" appears on the digital display, the power source has been reset

**IMPORTANT!** When the power source is reset, all personal settings in the Setup menu are lost.

Operating points that were saved using the "Save" buttons are retained when the power source is reset. The functions in the second level of the Setup menu (2nd) are also not deleted. Exception: Ignition time-out function parameter (ito).

---

**2nd Second level of the Setup menu (see "Setup menu - level 2")**

---

---

**Setup parameters  
for MIG/MAG  
standard syner-  
gic welding**

"Min." and "max." are used for setting ranges that differ according to power source, welding program, etc.

---

**GPr Gas pre-flow time**  
Unit: s  
Setting range: 0 - 9.9  
Factory setting: 0.1

---

**GPo Gas post-flow time**  
Unit: s  
Setting range: 0 - 9.9  
Factory setting: 0.1

---

**SL Slope**  
Unit: s  
Setting range: 0 - 9.9  
Factory setting: 0.1

---

**I-S I (current) - Starting current**  
Unit: % (of welding current)  
Setting range: 0 - 200  
Factory setting: 100

---

**I-E I (current) - End: Final current**  
Unit: % (of welding current)  
Setting range: 0 - 200  
Factory setting: 50

---

**t-S t (time) - Starting - Starting current duration**  
Unit: s  
Setting range: OFF, 0.1 - 9.9  
Factory setting: OFF

---

**t-E t (time) - End: Final current time**  
Unit: s  
Setting range: OFF, 0.1 - 9.9  
Factory setting: OFF

---

**Fdi Feeder inching - feeder inching speed**  
Unit: m/min (ipm.)  
Setting range: 1 - max. (39.37 - max.)  
Factory setting: 10 (393.7)

---

**bbc burn-back time correction -**  
Burn back effect due to wire withdrawal at end of welding  
Unit: s  
Setting range: Aut, 0 - 0.3  
Factory setting: Aut

---

**Ito Ignition time-out function - Length of wire that is fed before the safety cut-out is triggered**  
Unit: mm (in.)  
Setting range: Off, 5 - 100 (Off, 0.2 - 3.94)  
Factory setting: OFF



**NOTE!** The "Ignition time-out" function (ito) is a safety function. The length of wire that is fed before the safety cut-out trips may differ from the preset wire length, particularly when the wire is being fed at fast wire feed speeds.

The "Ignition time-out" function (ito) is explained in the "Special functions and options" section.

---

**SPt Spot time - spot / stitch welding time**

Unit: s

Setting range: OFF, 0.1 - 5

Factory setting: OFF

---

**SPb Spot break - stitch pause time**

Unit: s

Setting range: OFF, 0.1 - 10 (in 0.1 s increments)

Factory setting: OFF

---

**FAC Factory - reset power source to factory settings**

Press and hold down one of the "Parameter selection" buttons for 2 s to restore the factory settings

- when "PrG" appears on the digital display, the power source has been reset.

**IMPORTANT!** When the power source is reset, all personal settings in the Setup menu are lost.

When the power source is reset, operating points that were saved using the "Save" buttons are not deleted, but are retained in the memory. The functions in the second level of the Setup menu (2nd) are also not deleted. Exception: Ignition time-out function parameter (ito).

---

**2nd Second level of the Setup menu (see "Setup menu - level 2")**

---

---

**Setup parameters  
for MMA welding**

**IMPORTANT!** If you reset the power source using the FAC factory setup parameter, the hot-current time (Hti) and HotStart current (HCU) setup parameters are also reset.

---

**HCU HotStart current**

Unit: %

Setting range: 100 - 200

Factory setting: 150

---

**Hti Hot-current time**

Unit: s

Setting range: 0 - 2.0

Factory setting: 0.5

---

**Ast Anti-Stick**

Unit: -

Setting range: On, OFF

Factory setting: OFF

---

**FAC Factory - Reset power source to factory setting**

Press and hold down one of the "Parameter selection" buttons for 2 s to restore the factory settings

- when "PrG" appears on the digital display, the power source has been reset.

**IMPORTANT!** When the power source is reset, all personal settings are lost.

When the power source is reset, operating points that were saved using the "Save" buttons are not deleted, but are retained in the memory. The functions in the second level of the Setup menu (2nd) are also not deleted. Exception: Ignition time-out function parameter (ito).

---

**2nd Second level of the Setup menu (see "Setup menu - level 2")**

---

# Setup menu - Level 2

## Restrictions

In conjunction with the level 2 of the Setup menu, the following restrictions occur:

Level 2 of the Setup menu cannot be selected:

- during welding
- if the "Gas test" function is active
- if the "Wire threading" function is active
- if the "Wire withdrawal" function is active
- if the "Blow through" function is active

If level 2 of the Setup menu is selected, the following functions are not available, even in robot mode:

- Welding start-up - the "Power source ready" signal will not be emitted
- Gas testing
- Threading the wire
- Wire withdrawal
- Blow-through

## Configuring the setup parameters

### Accessing the Setup menu



**1** Press and hold the "Mode" button



**2** Press the "Process" button



**3** Release the "Mode" and "Process" buttons

The control panel is now in the Setup menu - the last setup parameter that was selected is displayed.

### Selecting the "2nd" parameter



**4** Use the "Mode" and "Process" buttons or the left-hand adjusting dial to select the "2nd" setup parameter



### Accessing the Level 2 Setup menu



**5** Press and hold the "Mode" button



**6** Press the "Process" button



**7** Release the "Mode" and "Process" buttons

## Changing welding parameters



**8** Use the "Mode" and "Process" buttons or the left-hand adjusting dial to select the required setup parameter



**9** Change the value of the setup parameter using the "Parameter selection" buttons or the right-hand adjusting dial



## Exiting the Level 2 Setup menu



**10** Press and hold the "Mode" button



**11** Press the "Process" button



**12** Release the "Mode" and "Process" buttons

## Exiting the Setup menu



**13** Press and hold the "Mode" button



**14** Press the "Process" button



**15** Release the "Mode" and "Process" buttons



**Parameters for  
MIG/MAG welding  
in the Setup menu  
level 2**

---

<b>C-C</b>	<p>Cooling unit Control (only with connected cooling unit)</p> <p>Unit: - Setting range: Aut, On, OFF Factory setting: Aut</p> <p>Aut: The cooling unit cuts out after a 2-minute welding off-time.</p> <p><b>IMPORTANT!</b> If the coolant temperature and flow monitoring options have been installed in the cooling unit, the cooling unit cuts out as soon as the return-flow temperature drops below 50 °C, but at the earliest after a 2-minute welding off-time.</p> <p>On: The cooling unit is always ON OFF: The cooling unit is always OFF</p> <p><b>IMPORTANT!</b> If the FAC welding parameter is used, the C-C parameter is not reset to the factory setting. If the MMA welding process is selected, the cooling unit is always switched off, even if the switch is in the "On" position.</p>
<hr/>	
<b>C-t</b>	<p>Cooling Time (only with connected cooling unit)</p> <p>Time from when flow monitoring is triggered until the "no   H2O" service code is output. For example, if there are air bubbles in the cooling system, the cooling unit will not cut out until the end of this preset time.</p> <p>Unit: s Setting range: 5 - 25 Factory setting: 10</p> <p><b>IMPORTANT!</b> Every time the power source is switched on, the cooling unit carries out a test run for 180 seconds.</p>
<hr/>	
<b>SEt</b>	<p>Setting - country-specific setting (Standard/USA) ... Std / US</p> <p>Unit: - Setting range: Std, US (Standard / USA) Factory setting: Standard version: Std (measurements: cm / mm) USA version: US (measurements: inches)</p>
<hr/>	
<b>r</b>	<p>r (resistance) - welding circuit resistance (in mOhm) see "Measuring welding circuit resistance r"</p>
<hr/>	
<b>L</b>	<p>L (inductivity) - welding circuit inductivity (in microhenry) see "Displaying welding circuit inductivity L"</p>
<hr/>	

---

**EnE** Real Energy Input – electrical energy of the arc relative to the welding speed

Unit: kJ

Setting range: ON / OFF

Factory setting: OFF

Since the full range of values (1 kJ - 99999 kJ) cannot be displayed on the three-digit display, the following display format has been selected:

Value in kJ / indicator on display:

1 to 999 / 1 to 999

1000 to 9999 / 1.00 to 9.99 (without "ones" digit, e.g. 5270 kJ -> 5.27)

10000 to 99999 / 10.0 to 99.9

(without "ones" and "tens" digits, e.g. 23580 kJ -> 23.6)

---

**ALC** Arc Length Correction - correction of the arc length via the welding voltage

Setting range: ON / OFF

Factory setting: OFF

The arc length depends on the welding voltage. The welding voltage can be adjusted to suit individual needs in Synergic operation.

If the ALC parameter is set to "OFF", the welding voltage cannot be adjusted. The welding voltage is automatically determined by the selected welding current or wire speed. If the arc length correction is adjusted, the voltage changes, but the welding current and wire speed remain the same. When setting the arc length correction using the adjusting dial, the left display is used for the correction value of the arc length. The welding voltage value on the right display changes simultaneously. Afterwards the left display shows the original value, e.g. welding current.

---

**Parameters for manual metal arc (MMA) welding in the Setup menu level 2**

---

**r** r (resistance) - welding circuit resistance (in mOhm)  
see "Measuring welding circuit resistance r"

---

**L** L (inductivity) - welding circuit inductivity (in microhenry)  
see "Displaying welding circuit inductivity L"

---

# Measuring welding circuit resistance r

## General

Measuring the welding circuit resistance  $r$  makes it possible to have a constant welding result at all times, even with hosepacks of different lengths. The welding voltage at the arc is then always precisely regulated, regardless of the length and cross-sectional area of the hosepack. The use of arc length correction is no longer required.

The calculated welding circuit resistance is shown on the display.

$r$  = welding circuit resistance in milliohm (mOhm)

If the welding circuit resistance  $r$  has been measured correctly, the set welding voltage will correspond exactly to the welding voltage at the arc. If you manually measure the voltage on the output jacks of the power source, this voltage will be higher than the welding voltage at the arc - that is, higher by the same amount as the voltage drop of the hosepack.



**NOTE!** The welding circuit resistance  $r$  depends on the hosepack used:

- If the length or cross-sectional area of the hosepack has changed, measure the welding circuit resistance  $r$  again
- Measure the welding circuit resistance for every welding process separately with the appropriate welding power-leads

## Measure the welding circuit resistance r



**NOTE!** In order to obtain good welding results, it is essential to measure the welding circuit resistance correctly. Make sure that the contact between the earthing clamp and the workpiece is on a cleaned workpiece surface.

- 1 Establish a grounding (earthing) connection to the workpiece
- 2 Accessing the Level 2 (2nd) Setup menu
- 3 Select parameter "r"
- 4 Remove the gas nozzle from the welding torch
- 5 Screw on the contact tip



**NOTE!** Make sure that the contact between the contact tip and the workpiece is on a cleaned workpiece surface.

- 6 Place the contact tip flush against the workpiece surface
- 7 Press the torch trigger briefly
  - The welding circuit resistance is calculated. "run" is shown on the display during the measurement.

The measurement is finished when the welding circuit resistance is shown on the display in mOhm (e.g. 11.4).

- 8 Fit the gas nozzle back onto the welding torch

# Displaying welding circuit inductivity L

---

## General

Laying of the hosepacks has a significant effect on welding circuit inductivity and therefore affects the welding process. It is important to lay the hosepacks correctly in order to obtain the best possible welding result.

---

## Displaying welding circuit inductivity L

The setup parameter "L" is used to display the most recently calculated welding circuit inductivity. The welding circuit inductivity is calibrated at the same time as the welding circuit resistance  $r$  is calculated. Detailed information can be found in the "Measuring welding circuit resistance  $r$ " section.

- 1 Access the setup menu level 2 (2nd)
- 2 Select parameter "L"

The most recently calculated welding circuit inductivity L is shown on the right-hand digital display.

L ... Welding circuit inductivity (in microhenry)

---

## Laying the hosepacks correctly

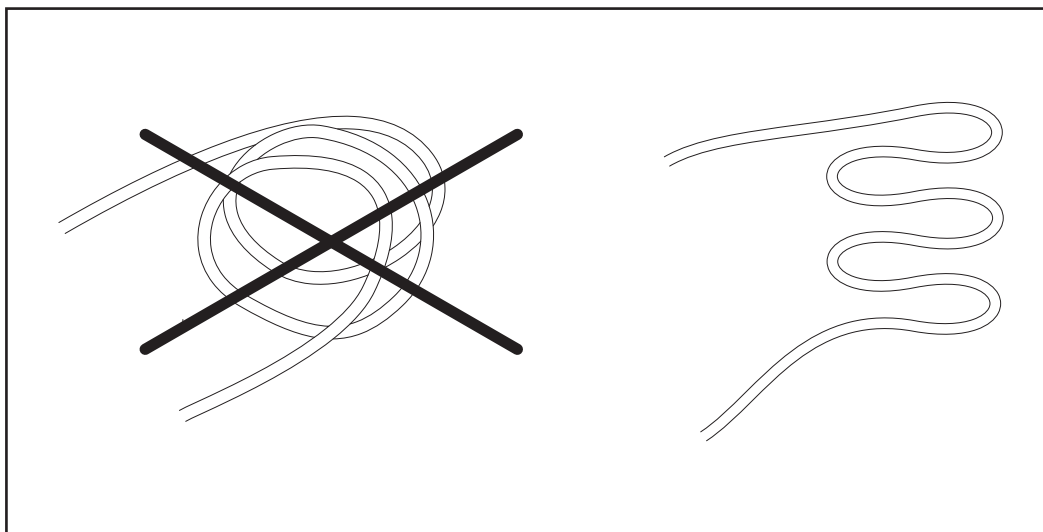

# **Troubleshooting and maintenance**



# Troubleshooting

## General

The devices are equipped with an intelligent safety system. This means that to a large extent it has been possible to dispense with melting-type fuses. Melting-type fuses therefore no longer need to be replaced. After a possible malfunction has been remedied, the device is ready for use again.

## Safety



**WARNING!** Work that is carried out incorrectly can cause serious injury or damage. The following activities must only be carried out by trained and qualified personnel. Observe the safety rules in the power source operating instructions.



**WARNING!** An electric shock can be fatal. Before opening the unit

- Turn the mains switch to the "O" position
- Unplug the device from the mains
- Put up an easy-to-understand warning sign to stop anybody inadvertently switching it back on again
- Using a suitable measuring device, check to make sure that electrically charged components (e.g. capacitors) have discharged



**CAUTION!** Inadequate PE conductor connections can cause serious injury and damage. The housing screws provide a suitable PE conductor connection for earthing (grounding) the housing and must NOT be replaced by any other screws which do not provide a reliable PE conductor connection.

## Fault diagnosis

Make a note of the serial number and configuration of the device and contact our After-Sales Service team with a detailed description of the error, if

- errors occur that are not listed below
- the troubleshooting measures listed are unsuccessful

---

### Power source has no function

Mains switch is on, but indicators are not lit up

Cause: There is a break in the mains lead; the mains plug is not plugged in

Remedy: Check the mains lead, ensure that the mains plug is plugged in

Cause: Mains socket or mains plug faulty

Remedy: Replace faulty parts

Cause: Mains fuse protection

Remedy: Change the mains fuse protection

---

### Nothing happens when the torch trigger is pressed

Power source mains switch is ON and indicators are lit up

Cause: Only for welding torches with an external control plug: The control plug is not plugged in

Remedy: Plug in the control plug

Cause: Welding torch or welding torch control line is faulty

Remedy: Replace welding torch

---

### **Nothing happens when the torch trigger is pressed**

Power source mains switch is on, power source ON indication is lit up on the power source, indications on wire-feed unit are not lit up

Cause: The interconnecting hosepack is faulty or not connected properly

Remedy: Check interconnecting hosepack

---

### **No welding current**

Mains switch is on, one of the overtemperature service codes "to" is displayed. Detailed information on the service codes "to0" to "to6" can be found in the section "Displayed service codes".

Cause: Overload

Remedy: Take the duty cycle into account

Cause: Thermostatic safety cut-out has tripped

Remedy: Wait until the power source automatically comes back on after the end of the cooling phase

Cause: Limited supply of cooling air

Remedy: Remove air filter on the rear of the housing from the side and clean. Ensure that the cooling air ducts are accessible.

Cause: The fan in the power source is faulty

Remedy: Contact After-Sales Service

---

### **No welding current**

Mains switch is ON and indicators are lit up

Cause: Grounding (earthing) connection is incorrect

Remedy: Check the grounding (earthing) connection for correct polarity

Cause: There is a break in the power cable in the welding torch

Remedy: Replace the welding torch

---

### **No protective gas shield**

All other functions are OK

Cause: Gas cylinder is empty

Remedy: Change the gas cylinder

Cause: The gas pressure regulator is faulty

Remedy: Replace the gas pressure regulator

Cause: Gas hose is not fitted or is damaged

Remedy: Fit or change the gas hose

Cause: Welding torch is faulty

Remedy: Change the welding torch

Cause: Gas solenoid valve is faulty

Remedy: Contact After-Sales Service

---



**Irregular wire feed speed**

Cause: Braking force has been set too high

Remedy: Loosen the brake

Cause: Hole in the contact tip is too narrow

Remedy: Use a suitable contact tip

Cause: Faulty inner liner in welding torch

Remedy: Check the inner liner for kinks, dirt, etc. and replace if necessary

Cause: The feed rollers are not suitable for the wire electrode being used

Remedy: Use suitable feed rollers

Cause: Feed rollers have the wrong contact pressure

Remedy: Optimise the contact pressure

---

**Wirefeed problems**

when using applications with long welding torch hosepacks

Cause: Incorrect arrangement of welding torch hosepack

Remedy: Arrange the welding torch hosepack in as straight a line as possible, avoiding bends

---

**Welding torch becomes very hot**

Cause: The specification of the welding torch is inadequate

Remedy: Observe the duty cycle and loading limits

Cause: Only on water-cooled systems: Inadequate coolant flow

Remedy: Check coolant level, coolant flow, for coolant contamination, etc. For further information refer to the cooling unit operating instructions.

---

### Poor weld properties

Cause: Incorrect welding parameters

Remedy: Check the settings

Cause: Poor ground earth connection

Remedy: Ensure good contact to workpiece

Cause: Inadequate or no protective gas shield

Remedy: Check the pressure regulator, gas hose, gas solenoid valve, torch gas connection, etc.

Cause: Welding torch is leaking

Remedy: Change the welding torch

Cause: Wrong contact tip, or contact tip is worn out

Remedy: Replace the contact tip

Cause: Wrong wire alloy or wrong wire diameter

Remedy: Check the wire electrode that has been inserted

Cause: Wrong wire alloy or wrong wire diameter

Remedy: Check weldability of the base material

Cause: The shielding gas is not suitable for this wire alloy

Remedy: Use the correct shielding gas

---

### Displayed service codes

If an error message that is not described here appears on the displays, proceed as follows to resolve the problem:

- 1 Turn the power source mains switch to the "O" position
- 2 Wait 10 seconds
- 3 Move the mains switch to the I position

If the error occurs again despite several attempts to eliminate it, or if the troubleshooting measures listed here are unsuccessful.

- 1 Make a note of the error message displayed
- 2 Note down the configuration of the power source
- 3 Contact our After-Sales Service team with a detailed description of the error

---

### ESr | 20

Cause: The selected cooling unit is not compatible with the power source

Remedy: Connect compatible cooling unit

---

-----

Cause: An invalid welding process was called up on the robot interface (no. 37) or an empty flag was selected (no. 32)

Remedy: Call up a valid welding process or select assigned "Save" button

---

**ELn | 8**

Cause: The connected wire-feed unit is not supported

Remedy: Connect supported wire-feed unit

---

**ELn | 12**

Cause: Different control panels for selecting materials are in the system

Remedy: Connect similar control panels to select materials

---

**ELn | 13**

Cause: Invalid change of welding process during welding

Remedy: During welding do not carry out any illegal change of the welding process, re-set error message by pressing any button

---

**ELn | 14**

Cause: More than only one robot interface is connected

Remedy: Only one robot interface may be connected, check the system configuration

---

**ELn | 15**

Cause: More than only one remote control unit is connected

Remedy: Only one remote control unit may be connected, check the system configuration

---

**Err | IP**

Cause: The control unit of the power source has detected a primary overvoltage

Remedy: Check mains voltage, if the service code still remains, switch off the power source, wait for 10 seconds and then switch the power source on again, if the error keeps recurring, contact After-Sales Service

---

**Err | PE**

Cause: The earth current watchdog has triggered the safety cut-out of the power source.

Remedy: Switch off the power source  
Place the power source on an insulating surface  
Connect the grounding (earthing) cable to a section of the workpiece that is closer to the arc  
Wait for 10 seconds and then switch the power source on again

If you have tried this several times and the error keeps recurring, contact After-Sales Service

---

**Err | Ur**

Cause: If the VRD option is available, the open circuit voltage limit of 35 V has been exceeded.

Remedy: Switch off power source  
Wait for 10 seconds and then switch the power source on again

---

**no | UrL**

Cause: The VRD option has tripped too early.

Remedy: Check whether all welding power-leads and control lines are connected.

Switch off the power source  
Wait 10 seconds and switch the power source back on again

If the error occurs again - contact After Sales Service.

---

### **E-Stop**

Cause: "External stop" has tripped

Remedy: Remedy the event that triggered the external stop

---

### **-St | oP-**

Cause: At the robot interface the flag was not deleted by the robot

Remedy: Delete the signal robot ready at the robot interface

---

### **PHA | SE**

Cause: Phase failure

**with TSt 2500c / TSt 2700c in particular:**

If the failure occurs during welding, the welding operation stops.

**with TSt 2500c MV / TSt 2700c MV in particular:**

A single-phase operation with limited power is possible:

When switching on the power source, "PHA | SE1" is displayed in order to show that a power reduction will be in effect.

If a change in supply from three-phase to single-phase occurs during welding (display: "PHA | SE1") or from single-phase to three-phase (display: "PH | ASE 3"), the welding operation stops.

Remedy: Check the mains fuse, mains cable and mains plug.

Switch off the power source, wait 10 seconds and switch the power source back on again.

---

### **PHA | SE1**

Cause: The power source is operated in single-phase mode.

Remedy: -

---

### **PHA | SE3**

Cause: The power source is operated in 3-phase mode

Remedy: -

---

### **Err | 51**

Cause: Mains undervoltage: The mains voltage has fallen below the tolerance range

Remedy: Check the mains voltage, if the error keeps recurring, contact the After-Sales Service

---

### **Err | 52**

Cause: Mains overvoltage: The mains voltage has risen above the tolerance range

Remedy: Check the mains voltage, if the error keeps recurring, contact the After-Sales Service

---

### **EFd 5**

Cause: Incorrect wire-feed unit connected

Remedy: Connect correct wire-feed unit

---

### **EFd 8**

Cause: Overtemperature on the wire-feed unit

Remedy: Allow wire-feed unit to cool down

---

**EFd | 81, EFd | 83**

Cause: Fault in the wire feed system (overcurrent in wire-feed unit drive)

Remedy: Arrange the hosepack in as straight a line as possible; check that there are no kinks or dirt in the inner liner; check the contact pressure on the 4 roller drive

Cause: Wire-feed unit motor is sticking or defective

Remedy: Check the wire-feed unit motor or contact After-Sales Service

**to0 | xxx**

Note: xxx stands for a temperature value

Cause: Overtemperature in the primary circuit of the power source

Remedy: Allow power source to cool down, check air filter and clean if necessary, check that fan is on

**to1 | xxx**

Note: xxx stands for a temperature value

Cause: Overtemperature on the booster located in the power source

Remedy: Allow power source to cool down, check air filter and clean if necessary, check that fan is on

**to2 | xxx**

Note: xxx stands for a temperature value

Cause: Overtemperature in the secondary circuit of the power source

Remedy: Allow power source to cool down, check that fan is on

**to3 | xxx**

Remark: xxx stands for a temperature value

Cause: Overtemperature in the wire-feed unit motor

Remedy: Allow wire-feed unit to cool down

**to4 | xxx**

Remark: xxx stands for a temperature value

Cause: Overtemperature in welding torch

Remedy: Allow welding torch to cool down

**to5 | xxx**

Note: xxx stands for a temperature value

Cause: Overtemperature in cooling unit

Remedy: Allow cooling unit to cool down, check that fan is on

**to6 | xxx**

Note: xxx stands for a temperature value

Cause: Overtemperature at the transformer of the power source

Remedy: Allow power source to cool down, check air filter and clean if necessary, check that fan is on

**to7 | xxx**

Note: xxx stands for a temperature value

Cause: Overtemperature in the power source

Remedy: Allow power source to cool down, check air filter and clean if necessary, check that fan is on

---

**toF | xxx**

Cause: With the TSt 2500c MV / TSt 2700c MV power source operating in single-phase mode, the power source safety cut-out has tripped in order to prevent the mains fuse from tripping.

Remedy: After a pause in welding of around 60 s, the message disappears and the power source is operational again.

---

**tu0 | xxx**

Remark: xxx stands for a temperature value

Cause: Undertemperature in the power source primary circuit

Remedy: Place power source in a heated room and allow to warm up

---

**tu1 | xxx**

Note: xxx stands for a temperature value

Cause: Undertemperature on the booster located in the power source

Remedy: Place power source in a heated room and allow it to warm up

---

**tu2 | xxx**

Remark: xxx stands for a temperature value

Cause: Undertemperature in the power source secondary circuit

Remedy: Place power source in a heated room and allow to warm up

---

**tu3 | xxx**

Remark: xxx stands for a temperature value

Cause: Undertemperature in the wire-feed unit motor

Remedy: Place wire-feed unit in a heated room and allow to warm up

---

**tu4 | xxx**

Remark: xxx stands for a temperature value

Cause: Undertemperature in the welding torch

Remedy: Place welding torch in a heated room and allow to warm up

---

**tu5 | xxx**

Remark: xxx stands for a temperature value

Cause: Undertemperature in the cooling unit

Remedy: Place cooling unit in a heated room and allow to warm up

---

**tu6 | xxx**

Note: xxx stands for a temperature value

Cause: Undertemperature on the transformer of the power source

Remedy: Place power source in a heated room and allow it to warm up

---

**tu7 | xxx**

Note: xxx stands for a temperature value

Cause: Undertemperature in the power source

Remedy: Place power source in a heated room and allow it to warm up

---

**no | H2O**

Cause: Coolant flow rate too low

Remedy: Check coolant flow rate and cooling unit, including cooling circuit (for minimum coolant flow, see "Technical Data" section in the device operating instructions)

---

**hot | H2O**

Cause: The coolant temperature is too high

Remedy: Allow cooling unit and cooling circuit to cool down, until "hot | H2O" is no longer displayed. Open the cooling unit and clean the cooler, check fan is working properly. Robot interface or field bus coupler: before resuming welding, set the "Source error reset" signal.

---

**no | Prg**

Cause: No preconfigured program has been selected

Remedy: Select a configured program

---

**no | IGn**

Cause: "Ignition time out" function is active; no current started flowing before the length of wire specified in the set-up menu had been fed. The power source safety cut-out has tripped.

Remedy: Shorten the wire end; press the torch trigger again; clean the surface of the workpiece; if necessary, increase the wire length until the safety cut-out trips in "Set-up menu: Level 2".

---

**EPG | 17**

Cause: The welding program selected is invalid

Remedy: Select valid welding program

---

**EPG | 29**

Cause: The required wire-feed unit is not available for the selected characteristic

Remedy: Connect correct wire-feed unit, check plug connections for the hosepack

---

**EPG | 35**

Cause: Measurement of the welding circuit resistance "r" failed

Remedy: Check grounding cable, current cable or hosepack and replace if necessary, recalculate welding circuit resistance "r"

---

**no | GAS**

Cause: The Gas watchdog option has detected that there is no gas pressure

Remedy: Connect a new gas cylinder or open the gas cylinder valve/pressure regulator, restart "Gas watchdog" option, reset "no | GAS" error message by pressing any button.

---

# Care, maintenance and disposal

---

## General

Under normal operating conditions, the welding system requires only a minimum of care and maintenance. However, it is vital to observe some important points to ensure the welding system remains in a usable condition for many years.

---

## Safety



**WARNING!** An electric shock can be fatal. Before opening the device

- Turn the mains switch to the "O" position
- Unplug the machine from the mains
- Prevent it from being switched on again
- Using a suitable measuring instrument, check to make sure that electrically charged components (e.g. capacitors) have discharged



**WARNING!** Work that is carried out incorrectly can cause serious injury and damage. The following activities must only be carried out by trained and qualified personnel. All instructions in the section headed "Safety rules" must be observed.

---

## At every start-up

- Check mains plug, mains cable, welding torch, interconnecting hosepack and grounding (earthing) connection for damage
- Check that there is a gap of 0.5 m (1 ft. 8 in.) all around the device to ensure that cooling air can flow and escape unhindered



**NOTE!** Air inlets and outlets must never be covered, not even partially.

---

## If necessary

If a lot of dust has accumulated:

TSt 2500c / TSt 2700c

- Remove the fin element on the rear of the housing
- Detach the air filter located behind and clean

TSt 3500c

- Remove the air filter on the rear of the housing from the side and clean
- 

## Every 2 months



**CAUTION!** Risk of damage. The air filter must only be fitted when dry.

- If required, clean air filter using dry compressed air or by washing it.
- 

## Every 6 months

- Dismantle device side panels and clean inside of device with dry reduced compressed air



**NOTE!** Risk of damage to electronic components. Do not bring air nozzle too close to electronic components.

- If a lot of dust has accumulated, clean the cooling air ducts.



---

**Disposal**

Dispose of in accordance with the applicable national and local regulations.

# Technical data

**Special voltages** For devices designed for special voltages, the technical data on the rating plate applies.

For all machines with a permitted mains voltage of up to 460 V: The standard mains plug allows the user to operate with a mains voltage of up to 400 V. For mains voltages up to 460 V fit a mains plug permitted for such use or install the mains supply directly.

## Explanation of the term "duty cycle"

Duty cycle (D.C.) is the proportion of time in a 10-minute cycle at which the device may be operated at its rated output without overheating.

 **NOTE!** The D.C. values specified on the rating plate are based on an ambient temperature of 40°C. If the ambient temperature is higher, either the D.C. or output must be reduced accordingly.

Example: Welding at 150 A at 60% D.C.

- Welding phase = 60% of 10 minutes = 6 minutes
- Cooling phase = remaining time = 4 minutes
- After the cooling phase, the cycle begins anew.

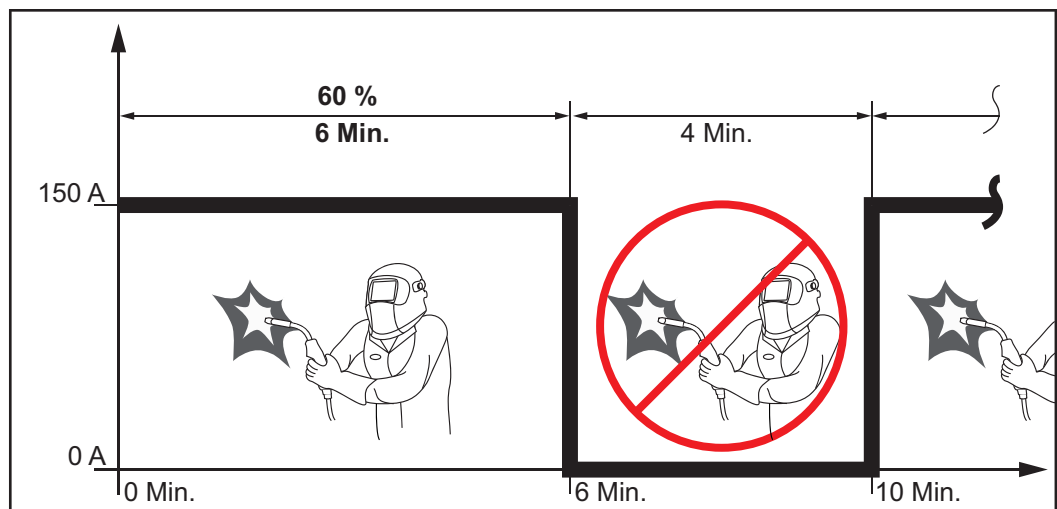

If the device is to be continuously operated without stopping:

- 1 look in the technical data for a D.C. value of 100% for the reigning ambient temperature.
- 2 Reduce the output or amperage in line with this value so that the device can remain in use without observing a cooling phase.

## TSt 2500c

Mains voltage ( $U_1$ )	3 x	380 V	400 V	460 V
Max. effective primary current ( $I_{1\text{eff}}$ )		7 A	6.7 A	5.6 A
Max. primary current ( $I_{1\text{max}}$ )		11.8 A	11.2 A	9.7 A
Mains fuse				16 A slow-blow
Mains voltage tolerance				-15 / +15%
Mains frequency				50 / 60 Hz
Max. permitted mains impedance $Z_{\text{max}}$ on PCC <sup>1)</sup>				136 mOhm
Welding current range ( $I_2$ )				
MIG / MAG				10 - 250 A
Rod electrode				10 - 250 A
Welding current at	10 min / 40°C (104°F)	40%	60%	100%
		250 A	210 A	170 A
Output voltage range according to standard characteristic ( $U_2$ )				
MIG / MAG				14.5 - 34.5 V
Rod electrode				20.4 - 30.0 V
Open circuit voltage ( $U_0$ peak / $U_0$ r.m.s)				41 V
Apparent power	at 400 V AC			7,76 kVA
Protection class				IP 23
Insulation class				B
Overvoltage category				III
Pollution level according to IEC60664				3
Safety symbols				S, CE, CSA
Efficiency at 170 A and 22.5 V				88%
Dimensions l x w x h				687 x 276 x 445 mm 27.1 x 10.9 x 17.5 in.
Weight				30 kg 66.1 lb.
Max. shielding gas pressure				7 bar 101.49 psi
Wire feed speed				1 - 25 m/min 40 - 980 ipm
Wire drive				4-roller drive
Wire diameter				0.8 - 1.6 mm 0.03 - 0.06 in.
Wirespool diameter				max. 300 mm max. 11.81 in.
Wirespool weight				max. 19.0 kg max. 41.9 lb.

1) Interface to a 230 / 400 V, 50 Hz public grid

**TSt 2500c MV**

Mains voltage ( $U_1$ )	3 x	200 V	230 V	
Max. effective primary current ( $I_{1\text{eff}}$ )		16.8 A	14.5 A	
Max. primary current ( $I_{1\text{max}}$ )		26.0 A	22.4 A	
Mains fuse protection (slow-blow)			25 A	
Mains voltage ( $U_1$ )	3 x	380 V	400 V	460 V
Max. effective primary current ( $I_{1\text{eff}}$ )		8.6 A	8.2 A	7.1 A
Max. primary current ( $I_{1\text{max}}$ )		13.2 A	12.6 A	10.9 A
Mains fuse protection (slow-blow)				15 A
Mains voltage ( $U_1$ )	1 x	230 V	240 V	240 V
Max. effective primary current ( $I_{1\text{eff}}$ )		16.0 A	15.0 A	18.1 A
Max. primary current ( $I_{1\text{max}}$ )		22.3 A	23.9 A	28.1 A
Mains fuse protection (slow-blow)		16 A	15 A	20 A
Apparent power		5.13 kVA	5.74 kVA	5.98 kVA
Mains voltage tolerance				-10 / +15 %
Mains frequency				50 / 60 Hz
Max. permitted mains impedance $Z_{\text{max}}$ on PCC <sup>1)</sup>				142 mOhm
Welding current range ( $I_2$ )				
MIG / MAG				10 - 250 A
Rod electrode				10 - 250 A
Welding current range ( $I_2$ ) in single-phase operation				
MIG / MAG				10 - 220 A
Rod electrode				10 - 180 A
Welding current at	10 min / 40°C (104°F)	40%	60%	100%
$U_1 = 200 - 230$ V:		250 A	200 A	170 A
$U_1 = 380 - 460$ V:		250 A	200 A	170 A
Welding current in single-phase operation at	10 min / 40°C (104°F)	15% <sup>2)</sup>		100%
$U_1 = 230$ V:	Fuse 16 A	180 A		145 A
Welding current in single-phase operation at	10 min / 40°C (104°F)	8% <sup>2)</sup>		100%
$U_1 = 240$ V:	Fuse 15 A	180 A		145 A
Welding current in single-phase operation at	10 min / 40°C (104°F)	11% <sup>2)</sup>		100%
$U_1 = 240$ V:	Fuse 20 A	200 A		160 A
Welding current in single-phase operation at	10 min / 40°C (104°F)	40% <sup>2)</sup>		100%
$U_1 = 240$ V:	Fuse 30 A	220 A		160 A
Output voltage range according to standard characteristic ( $U_2$ )				
MIG / MAG				14.5 - 34.5 V
Rod electrode				20.4 - 30.0 V
Output voltage range according to standard characteristic ( $U_2$ ) in single-phase operation				

MIG / MAG	14.5- 24 V
Rod electrode	20.4 - 27.2 V
Open circuit voltage ( $U_0$ peak / $U_0$ r.m.s)	42 V
Apparent power at 400 V AC	7,76 kVA
Protection class	IP 23
Insulation class	B
Overvoltage category	III
Pollution level according to IEC60664	3
Safety symbols	S, CE, CSA
Efficiency at 220 A and 25.0 V	87%
Dimensions l x w x h	687 x 276 x 445 mm 27.1 x 10.9 x 17.5 in.
Weight	30 kg 66.1 lb.
Max. shielding gas pressure	7 bar 101.49 psi
Wire feed speed	1 - 25 m/min 40 - 980 ipm.
Wire drive	4-roller drive
Wire diameter	0.8 - 1.6 mm 0.03 - 0.06 in.
Wirespool diameter	max. 300 mm max. 11.81 in.
Wirespool weight	max. 20.0 kg max. 44.1 lb.

- 1) Interface to a 230 / 400 V, 50 Hz public grid
- 2) Detailed information concerning the duty cycle in single-phase operation is located in chapter „Installation and commissioning“, section „single-phase operation“

**TSt 2700c**

Mains voltage ( $U_1$ )	3 x	380 V	400 V	460 V
Max. effective primary current ( $I_{1\text{eff}}$ )		7 A	6.6 A	5.8 A
Max. primary current ( $I_{1\text{max}}$ )		13.1 A	12.5 A	10.8 A
Mains fuse				16 A slow-blow
Mains voltage tolerance				-15 / +15%
Mains frequency				50 / 60 Hz
Max. permitted mains impedance $Z_{\text{max}}$ on PCC <sup>1)</sup>				136 mOhm
Welding current range ( $I_2$ )				
MIG / MAG				10 - 270 A
Rod electrode				10 - 270 A
Welding current at	10 min / 40°C (104°F)	30%	60%	100%
		270 A	210 A	170 A
Output voltage range according to standard characteristic ( $U_2$ )				
MIG / MAG				14.5 - 34.9 V
Rod electrode				20.4 - 34.9 V
Open circuit voltage ( $U_0$ peak / $U_0$ r.m.s)				41 V
Apparent power	at 400 V AC			8,66 kVA
Protection class				IP 23
Insulation class				B
Overvoltage category				III
Pollution level according to IEC60664				3
Safety symbols				S, CE
Efficiency at 170 A and 22.5 V				88%
Dimensions l x w x h				687 x 276 x 445 mm 27.1 x 10.9 x 17.5 in.
Weight				30 kg 66.1 lb.
Max. shielding gas pressure				7 bar 101.49 psi
Wire feed speed				1 - 25 m/min 40 - 980 ipm
Wire drive				4-roller drive
Wire diameter				0.8 - 1.6 mm 0.03 - 0.06 in.
Wirespool diameter				max. 300 mm max. 11.81 in.
Wirespool weight				max. 19.0 kg max. 41.9 lb.

1) Interface to a 230 / 400 V, 50 Hz public grid

**TSt 2700c MV**

Mains voltage ( $U_1$ )	3 x	200 V	230 V	
Max. effective primary current ( $I_{1\text{eff}}$ )		13.3 A	11.6 A	
Max. primary current ( $I_{1\text{max}}$ )		25.7 A	22.41 A	
Mains fuse protection (slow-blow)			25 A	
Mains voltage ( $U_1$ )	3 x	380 V	400 V	460 V
Max. effective primary current ( $I_{1\text{eff}}$ )		7 A	6.6 A	5.8 A
Max. primary current ( $I_{1\text{max}}$ )		13.1 A	12.5 A	10.8 A
Mains fuse protection (slow-blow)				15 A
Apparent power at 400 V AC				8,66 kVA
Mains voltage ( $U_1$ )	1 x	230 V	240 V	240 V
Max. effective primary current ( $I_{1\text{eff}}$ )		16.0 A	15.0 A	18.1 A
Max. primary current ( $I_{1\text{max}}$ )		22.3 A	23.9 A	28.1 A
Mains fuse protection (slow-blow)		16 A	15 A	20 A
Apparent power		5.13 kVA	5.74 kVA	5.98 kVA
Mains voltage tolerance				-10 / +15 %
Mains frequency				50 / 60 Hz
Max. permitted mains impedance $Z_{\text{max}}$ on PCC <sup>1)</sup>				142 mOhm
Welding current range ( $I_2$ )				
MIG / MAG				10 - 270 A
Rod electrode				10 - 270 A
Welding current range ( $I_2$ ) in single-phase operation				
MIG / MAG				10 - 220 A
Rod electrode				10 - 180 A
Welding current at 10 min / 40°C (104°F)		30%	60%	100%
$U_1 = 200 - 230$ V:		270 A	200 A	170 A
$U_1 = 380 - 460$ V:		270 A	200 A	170 A
Welding current in single-phase operation at 10 min / 40°C (104°F)		15% <sup>2)</sup>		100%
$U_1 = 230$ V: Fuse 16 A		180 A		145 A
Welding current in single-phase operation at 10 min / 40°C (104°F)		8% <sup>2)</sup>		100%
$U_1 = 240$ V: Fuse 15 A		180 A		145 A
Welding current in single-phase operation at 10 min / 40°C (104°F)		11% <sup>2)</sup>		100%
$U_1 = 240$ V: Fuse 20 A		200 A		160 A
Welding current in single-phase operation at 10 min / 40°C (104°F)		40% <sup>2)</sup>		100%
$U_1 = 240$ V: Fuse 30 A		220 A		160 A
Output voltage range according to standard characteristic ( $U_2$ )				
MIG / MAG				14.5 - 34.3 V
Rod electrode				20.4 - 34.3 V

Output voltage range according to standard characteristic ( $U_2$ ) in single-phase operation	
MIG / MAG	14.5- 24 V
Rod electrode	20.4 - 27.2 V
Open circuit voltage ( $U_0$ peak / $U_0$ r.m.s)	
	42 V
Protection class	
	IP 23
Insulation class	
	B
Overvoltage category	
	III
Pollution level according to IEC60664	
	3
Safety symbols	
	S, CE, CSA
Efficiency at 220 A and 25.0 V	
	87%
Dimensions l x w x h	
	687 x 276 x 445 mm 27.1 x 10.9 x 17.5 in.
Weight	
	30 kg 66.1 lb.
Max. shielding gas pressure	
	7 bar 101.49 psi
Wire feed speed	
	1 - 25 m/min 40 - 980 ipm.
Wire drive	
	4-roller drive
Wire diameter	
	0.8 - 1.6 mm 0.03 - 0.06 in.
Wirespool diameter	
	max. 300 mm max. 11.81 in.
Wirespool weight	
	max. 20.0 kg max. 44.1 lb.

- 1) Interface to a 230 / 400 V, 50 Hz public grid
- 2) Detailed information concerning the duty cycle in single-phase operation is located in chapter „Installation and commissioning“, section „single-phase operation“



## TSt 3500c

Mains voltage ( $U_1$ )	3 x	380 V	400 V	460 V
Max. effective primary current ( $I_{1\text{eff}}$ )		15.2 A	14.5 A	12.7 A
Max. primary current ( $I_{1\text{max}}$ )		23.9 A	23.0 A	20.1 A
Mains fuse		35 A slow-blow		
Mains voltage tolerance		-10 / +15 %		
Mains frequency		50/60 Hz		
Cos phi (1)		0.99		
Max. permitted mains impedance $Z_{\text{max}}$ at PCC <sup>1)</sup>		77 mOhm		
Recommended earth-leakage circuit breaker		Type B		
Welding current range ( $I_2$ )				
MIG/MAG		10 - 350 A		
Rod electrode		10 - 350 A		
Welding current at	10 min / 40 °C (104 °F)	40 %	60 %	100 %
		350 A	300 A	250 A
Output voltage range according to standard characteristic ( $U_2$ )				
MIG/MAG		14.5 - 38.5 V		
Rod electrode		20.4 - 35.0 V		
Open circuit voltage ( $U_0$ peak / $U_0$ r.m.s)		60 V		
Apparent power at 400 V AC		15.87 kVA		
Degree of protection		IP 23		
Type of cooling		AF		
Insulation class		B		
Overvoltage category		III		
Pollution level according to IEC60664		3		
Safety symbols		S, CE, CSA		
Dimensions l x w x h		747 x 300 x 497 mm 29.4 x 11.8 x 19.6 in.		
Weight		36 kg 79.4 lb.		
Max. shielding gas pressure		5 bar / 72.52 psi		
Coolant		Original Fronius		
Wire feed speed		1 - 25 m/min / 40 - 980 ipm		
Wire drive		4-roller drive		
Wire diameter		0.8 - 1.6 mm / 0.03 - 0.06 in.		
Wirespool diameter		max. 300 mm / max. 11.81 in.		
Wirespool weight		max. 19.0 kg / max. 41.9 lb.		
Efficiency at 250 A and 26.5 V		89 %		
Max. noise emission ( $L_{\text{WA}}$ )		72 dB (A)		

1) Interface to a 230/400 V, 50 Hz public grid

# Appendix

## Quick reference

### TransSteel Synergic

#### 1 Selecting the filler metal and shielding gas

SP ... Special Program

#### 2 Selecting the process

MANUAL  
SYNERGIC  
STICK

MANUAL MIG/MAG standard manual  
SYNERGIC Standard synergic  
STICK Manual metal arc welding

#### 3 Setting the mode

2T  
4T  
S4T

2 T 2-step mode  
4 T 4-step mode  
S 4 T Special 4-step mode

### Quick Reference: English

#### 5 Correcting parameters

Arc length correction  
Welding voltage  
Dynamic  
Real Energy Input

- select desired parameter  
- set desired parameter

**Important** if external system components are connected, some parameters can be modified on those components. The power source control panel is only for display purposes.

#### Keylock

activate / deactivate:

- press and hold
- press
- release

activated: „CLO | SEd“ display  
deactivated: „OP | En“ display

**Important!** If the keylock is activated, only the parameter settings can be retrieved, as well as any assigned "Save" button provided that an assigned "Save" button was selected when the keylock was enabled.

#### 4 Setting the welding power

Sheet thickness  
Welding current  
Wire feed speed

- select desired parameter  
- set desired parameter

- 1 - 5 Start-up sequence
- Follow operating instructions



Fronius International GmbH, www.fronius.com

01/2013

**MIG/MAG - setup**

Synergic



- G P r* Gas pre-flow time
- G P o* Gas post-flow time
- S L* Slope (2-step, special 4-step)
- I - 5* Starting current (2-step, special 4-step)
- I - E* Final current (2-step, special 4-step)
- E - 5* Starting current duration (2-step)
- E - E* Final current duration (2-step)
- F d i* Threading speed
- b b c* Burn-back effect
- i l o* Length of wire before the safety cut-out trips
- F A C* Restoring factory setup
- 2nd menu level**
- C - C* Cooling unit control
- C - E* Cooling unit watchdog
- S E E* Country setting
- r* Welding circuit resistance
- L* Welding circuit inductivity
- E n E* Real Energy Input

**MIG/MAG - setup**

Manual



- G P r* Gas pre-flow time
- G P o* Gas post-flow time
- F d i* Threading speed
- b b c* Burn-back effect
- i l o* Ignition current
- i l o* Length of wire before the safety cut-out trips
- F A C* Restoring factory setup
- 2nd menu level**
- C - C* Cooling unit control
- C - E* Cooling unit watchdog
- S E E* Country setting
- r* Welding circuit resistance
- L* Welding circuit inductivity
- E n E* Real Energy Input

**Rod electrode - setup**



- H C U* Hot-start current
- H E i* Hot-current time
- A S E* Anti-stick
- F A C* Restoring factory setup
- 2nd menu level**
- r* Welding circuit resistance
- L* Welding circuit inductivity

**Setup**



e.g.: 1.00 4.2 1  
firmware version

e.g.: 2 49 1  
welding program configuration

e.g.: r 2 290  
number of the currently selected welding program

e.g.: 1 f d 0.0  
motor current for wire drive in A

The value changes as soon as the motor is running.

e.g.: 654 32.1  
Arc burning time

**2. Menu level** for service engineers

**Display service parameters**

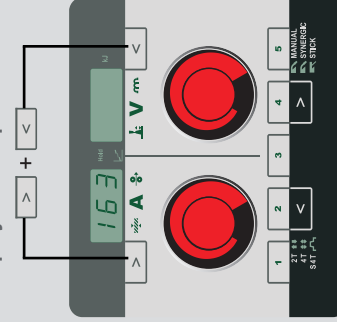

Steel	1	2	3	4	5
Wire type	0.8	0.9	1.0	1.2	1.6
Wire diameter	0.8	0.9	1.0	1.2	1.6
Shielding gas	Ar+CO2	Ar+CO2	Ar+CO2	Ar+CO2	Ar+CO2
Shielding gas flow	12	12	12	12	12
Shielding gas pressure	1.2	1.2	1.2	1.2	1.2
Shielding gas temperature	1.2	1.2	1.2	1.2	1.2
Shielding gas humidity	1.2	1.2	1.2	1.2	1.2
Shielding gas dew point	1.2	1.2	1.2	1.2	1.2

**Operating points**

1 2 3 4 5 "Save" buttons

retrieve:

1 163

briefly press

save:

1 P r o 163 1

press and hold release

delete:

1 P r o 163 C L r 1

press and hold down for several seconds release

**TSt 2500c / TSt 2700c welding program table**

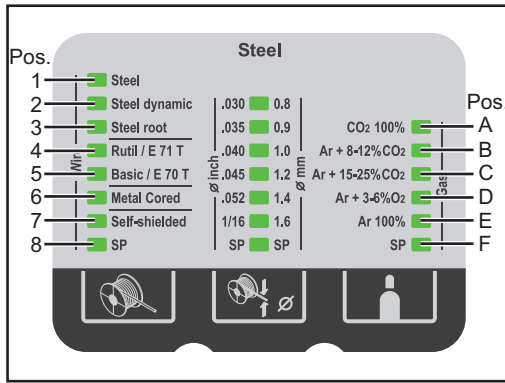

Welding program database:  
TSt 2500c / TSt 2700c  
VAT ID 3474

Standard Programs										
Material		Gas		Diameter						
Pos.		Pos.		0,8 mm .030"	0,9 mm .035"	1,0 mm .040"	1,2 mm .045"	1,4 mm .052"	1,6 mm 1/16"	SP
1	Steel	A	100 % CO <sub>2</sub>	2290	2300	2310	2322			
1	Steel	B	Ar + 8-12 % CO <sub>2</sub>	2288	2298	2308	2324			
1	Steel	C	Ar + 15-25 % CO <sub>2</sub>	2485	2486	2487	2488			
1	Steel	D	Ar + 3-6 % O <sub>2</sub>	2285	2297	2307	2323			
1	Stainless Steel	F	Ar + 2,5 % CO <sub>2</sub>	2427	2402	2426	2405			
2	Steel dynamic	B	Ar + 8-12 % CO <sub>2</sub>	2292	2302	2312	2326			
2	Steel dynamic	C	Ar + 15-25 % CO <sub>2</sub>	2293	2303	2313	2327			
2	Steel dynamic	D	Ar + 3-6 % O <sub>2</sub>	2291	2301	2311	2325			
3	Steel root	A	100 % CO <sub>2</sub>	2502	2501	2499	2500			
3	Steel root	B	Ar + 8-12 % CO <sub>2</sub>	2295	2305	2315	2329			
3	Steel root	C	Ar + 15-25 % CO <sub>2</sub>	2296	2306	2316	2330			
3	Steel root	D	Ar + 3-6 % O <sub>2</sub>	2294	2304	2314	2328			
3	Stainless Steel root	F	Ar + 2,5 % CO <sub>2</sub>	2440	2441	2442	2443			
4	Rutil FCW	A	100 % CO <sub>2</sub>		2410		2321			
4	Rutil FCW	C	Ar + 15-25 % CO <sub>2</sub>		2411		2320			
5	Basic FCW	A	100 % CO <sub>2</sub>				2317			
5	Basic FCW	C	Ar + 15-25 % CO <sub>2</sub>				2318			
6	Metal cored	B	Ar + 8-12 % CO <sub>2</sub>		2420		2385			
6	Metal cored	C	Ar + 15-25 % CO <sub>2</sub>		2421		2536			
7	Self-shielded				2350		2349			

Special assignment										
Material		Gas		Diameter						
Pos.		Pos.		0,8 mm .030"	0,9 mm .035"	1,0 mm .040"	1,2 mm .045"	1,4 mm .052"	1,6 mm 1/16"	SP
1	Stainless Steel	F	Ar + 2,5 % CO <sub>2</sub>	2427	2402	2426	2405			
3	Stainless Steel root	F	Ar + 2,5 % CO <sub>2</sub>	2440	2441	2442	2443			
8	FCW Stainless Steel	C	Ar + 18 % CO <sub>2</sub>		2423		2424			
8	AlMg5	E	100 % Ar			3639	3643			
1	AISI5	E	100 % Ar			3640	3092			
8	CuSi3	F	100 % Ar (Ar + 2,5 % CO <sub>2</sub> )	2496	2495	2493	2497			

\* Diameter = 1,2 mm (0.45 in.)

**TSt 2500c USA /  
TSt 2700c USA  
welding program  
table**

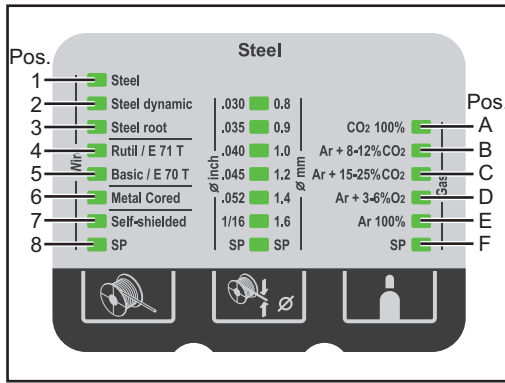

Welding program database:  
TSt 2500c USA / TSt 2700c USA  
VAT ID 3475

Standard Programs										
Material		Gas		Diameter						
Pos.		Pos.		0,8 mm .030"	0,9 mm .035"	1,0 mm .040"	1,2 mm .045"	1,4 mm .052"	1,6 mm 1/16"	SP
1	Steel	A	100 % CO2	2290	2300	2310	2322			
1	Steel	B	Ar + 8-12 % CO2	2418	2370	2308	2377			
1	Steel	C	Ar + 15-25 % CO2	2419	2369	2309	2376			
1	Steel	D	Ar + 3-6 % O2	2372	2371	2307	2378			
2	Steel dynamic	B	Ar + 8-12 % CO2	2374	2367	2312	2380			
2	Steel dynamic	C	Ar + 15-25 % CO2	2375	2366	2313	2379			
2	Steel dynamic	D	Ar + 3-6 % O2	2373	2368	2311	2381			
2	Steel dynamic	B	Ar + 8-12 % CO2		2462					
3	Steel root	A	100 % CO2	2502	2501	2499	2500			
3	Steel root	B	Ar + 8-12 % CO2	2295	2364	2315	2383			
3	Steel root	C	Ar + 15-25 % CO2	2296	2363	2316	2382			
3	Steel root	D	Ar + 3-6 % O2	2294	2365	2314	2384			
3	Stainless Steel root	F	Ar + 2,5 % CO2	2440	2441	2442	2443			
4	Rutil FCW	A	100 % CO2		2471		2472			
4	Rutil FCW	C	Ar + 15-25 % CO2		2470		2456			
5	Basic FCW	A	100 % CO2				2474			
5	Basic FCW	C	Ar + 15-25 % CO2				2473			
6	Metal cored	B	Ar + 8-12 % CO2		2420		2385			
6	Metal cored	C	Ar + 15-25 % CO2		2421		2386			
6	FCW Stainless Steel	F	Ar + 18 % CO2		2423		2424			
7	Self-shielded				2350		2349			

Special assignment										
Material		Gas		Diameter						
Pos.		Pos.		0,8 mm .030"	0,9 mm .035"	1,0 mm .040"	1,2 mm .045"	1,4 mm .052"	1,6 mm 1/16"	SP
3	Stainless Steel root	F	Ar + 2,5 % CO2	2440	2441	2442	2443			
6	FCW Stainless Steel	F	Ar + 18 % CO2		2423		2424			
8	Stainless Steel	A	Ar + 90He + 2,5 % CO2		2404		2407			
8	Stainless Steel	B	Ar + 33He + 1 % CO2		2403		2406			
8	Stainless Steel	C	Ar + 2,5 % CO2	2427	2402	2426	2405			
8	FCW MAP409Ti	D	Ar + 2 % O2				2464			
8	AlMg5	E	100 % Ar			3639	3643			
1	AlSi5	E	100 % Ar			3640	3092			
8	CuSi3	F	100 % Ar (Ar + 2,5 % CO2)	2496	2495	2493	2497			

\* Diameter = 1,2 mm (0.45 in.)

**TransSteel 3500  
Euro welding pro-  
gram tables**

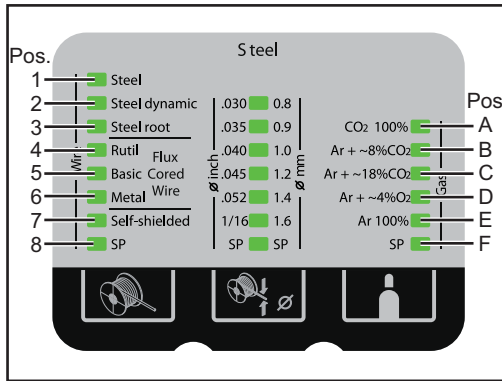

Welding program database:  
TransSteel 3500 Euro  
VAT ID 3431

Standard Programs										
Material		Gas		Diameter						
Pos.		Pos.		0,8 mm .030"	0,9 mm .035"	1,0 mm .040"	1,2 mm .045"	1,4 mm .052"	1,6 mm 1/16"	SP
1	Steel	A	100 % CO2	2290	2300	2310	2322	2334		
1	Steel	B	Ar + 8 % CO2	2288	2298	2308	2324	2332		
1	Steel	C	Ar + 18 % CO2	2485	2486	2487	2488	2489		
1	Steel	D	Ar + 4 % O2	2285	2297	2307	2323	2331		
2	Steel dynamic	B	Ar + 8 % CO2	2292	2302	2312	2326	2336		
2	Steel dynamic	C	Ar + 18 % CO2	2293	2303	2313	2327	2337		
2	Steel dynamic	D	Ar + 4 % O2	2291	2301	2311	2325	2335		
3	Steel root	A	100 % CO2	2502	2501	2499	2500			
3	Steel root	B	Ar + 8 % CO2	2295	2305	2315	2329	2339		
3	Steel root	C	Ar + 18 % CO2	2296	2306	2316	2330	2340		
3	Steel root	D	Ar + 4 % O2	2294	2304	2314	2328	2338		
4	Rutil FCW	A	100 % CO2		2410		2321	2391	2345	
4	Rutil FCW	C	Ar + 18 % CO2		2411		2320	2390	2344	
5	Basic FCW	A	100 % CO2				2317	2433	2342	
5	Basic FCW	C	Ar + 18 % CO2				2318	2432	2341	
6	Metal cored	B	Ar + 8 % CO2		2420		2385	2387	2415	
6	Metal cored	C	Ar + 18 % CO2		2421		2536	2388	2343	
7	Self-shielded		Self-shielded		2350		2349		2348	

Special assignment										
Material		Gas		Diameter						
Pos.		Pos.		0,8 mm .030"	0,9 mm .035"	1,0 mm .040"	1,2 mm .045"	1,4 mm .052"	1,6 mm 1/16"	SP
1	Stainless Steel	F	Ar + 2,5 % CO2	2427	2402	2426	2405			
3	Stainless Steel root	F	Ar + 2,5 % CO2	2440	2441	2442	2443			
8	FCW Stainless Steel	C	Ar + 18 % CO2		2423		2424		2425	
8	AlMg 5	E	100 % Ar				2444			
8	AlSi	E	100 % Ar							3092 *
8	CuSi 3	F	SP	2496	2495	2493	2497			

\* Diameter = 1,2 mm (0.45 in.)

**TransSteel 3500  
US welding pro-  
gram tables**

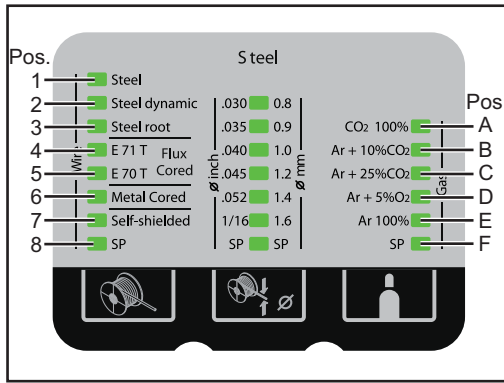

Welding program database:  
TransSteel 3500 US  
VAT ID 3431

Standard Programs										
Material		Gas		Diameter						
Pos.		Pos.		0,8 mm .030"	0,9 mm .035"	1,0 mm .040"	1,2 mm .045"	1,4 mm .052"	1,6 mm 1/16"	SP
1	Steel	A	100 % CO <sub>2</sub>	2290	2300	2310	2322	2334		
1	Steel	B	Ar + 10 % CO <sub>2</sub>	2418	2370	2308	2377	2409		
1	Steel	C	Ar + 25 % CO <sub>2</sub>	2419	2369	2309	2376	2333		
1	Steel	D	Ar + 5 % O <sub>2</sub>	2372	2371	2307	2378	2408		
2	Steel dynamic	B	Ar + 10 % CO <sub>2</sub>	2374	2367	2312	2380	2336		
2	Steel dynamic	C	Ar + 25 % CO <sub>2</sub>	2375	2366	2313	2379	2337		
2	Steel dynamic	D	Ar + 5 % O <sub>2</sub>	2373	2368	2311	2381	2335		
2	Steel dynamic	B	Ar + 10 % CO <sub>2</sub>		2462					
3	Steel root	A	100 % CO <sub>2</sub>	2502	2501	2499	2500			
3	Steel root	B	Ar + 10 % CO <sub>2</sub>	2295	2364	2315	2383	2339		
3	Steel root	C	Ar + 25 % CO <sub>2</sub>	2296	2363	2316	2382	2340		
3	Steel root	D	Ar + 5 % O <sub>2</sub>	2294	2365	2314	2384	2338		
4	Rutil FCW	A	100 % CO <sub>2</sub>		2471		2472	2467	2469	
4	Rutil FCW	C	Ar + 25 % CO <sub>2</sub>		2470		2456	2466	2468	
5	Basic FCW	A	100 % CO <sub>2</sub>				2474	2433	2476	
5	Basic FCW	C	Ar + 25 % CO <sub>2</sub>				2473	2432	2475	
6	Metal cored	B	Ar + 10 % CO <sub>2</sub>		2420		2385	2387	2415	
6	Metal cored	C	Ar + 25 % CO <sub>2</sub>		2421		2386	2388	2416	
7	Self-shielded		Self-shielded		2350		2349		2348	

Special assignment										
Material		Gas		Diameter						
Pos.		Pos.		0,8 mm .030"	0,9 mm .035"	1,0 mm .040"	1,2 mm .045"	1,4 mm .052"	1,6 mm 1/16"	SP
3	Stainless Steel root	F	Ar + 2,5 % CO <sub>2</sub>	2440	2441	2442	2443			
6	FCW Stainless Steel	F	Ar + 18 % CO <sub>2</sub>		2423		2424		2425	
8	Stainless Steel	A	Ar + 90 % He + 2,5 % CO <sub>2</sub>		2404		2407			
8	Stainless Steel	B	Ar + 33 % He + 1 % CO <sub>2</sub>		2403		2406			
8	Stainless Steel	C	Ar + 2,5 % CO <sub>2</sub>	2427	2402	2426	2405			
8	FCW MAP409Ti	D	Ar + 2 % O <sub>2</sub>				2464	2465		
8	AlMg 5	E	100 % Ar				2444			
8	AlSi	E	100 % Ar							3092*
8	CuSi 3	F	SP	2496	2495	2493	2497			

\* Diameter = 1,2 mm (0.45 in.)



**FRONIUS INTERNATIONAL GMBH**

Froniusplatz 1, A-4600 Wels, Austria

Tel: +43 (0)7242 241-0, Fax: +43 (0)7242 241-3940

E-Mail: [sales@fronius.com](mailto:sales@fronius.com)

[www.fronius.com](http://www.fronius.com)

**[www.fronius.com/addresses](http://www.fronius.com/addresses)**

Under <http://www.fronius.com/addresses> you will find all addresses  
of our Sales & service partners and Locations