

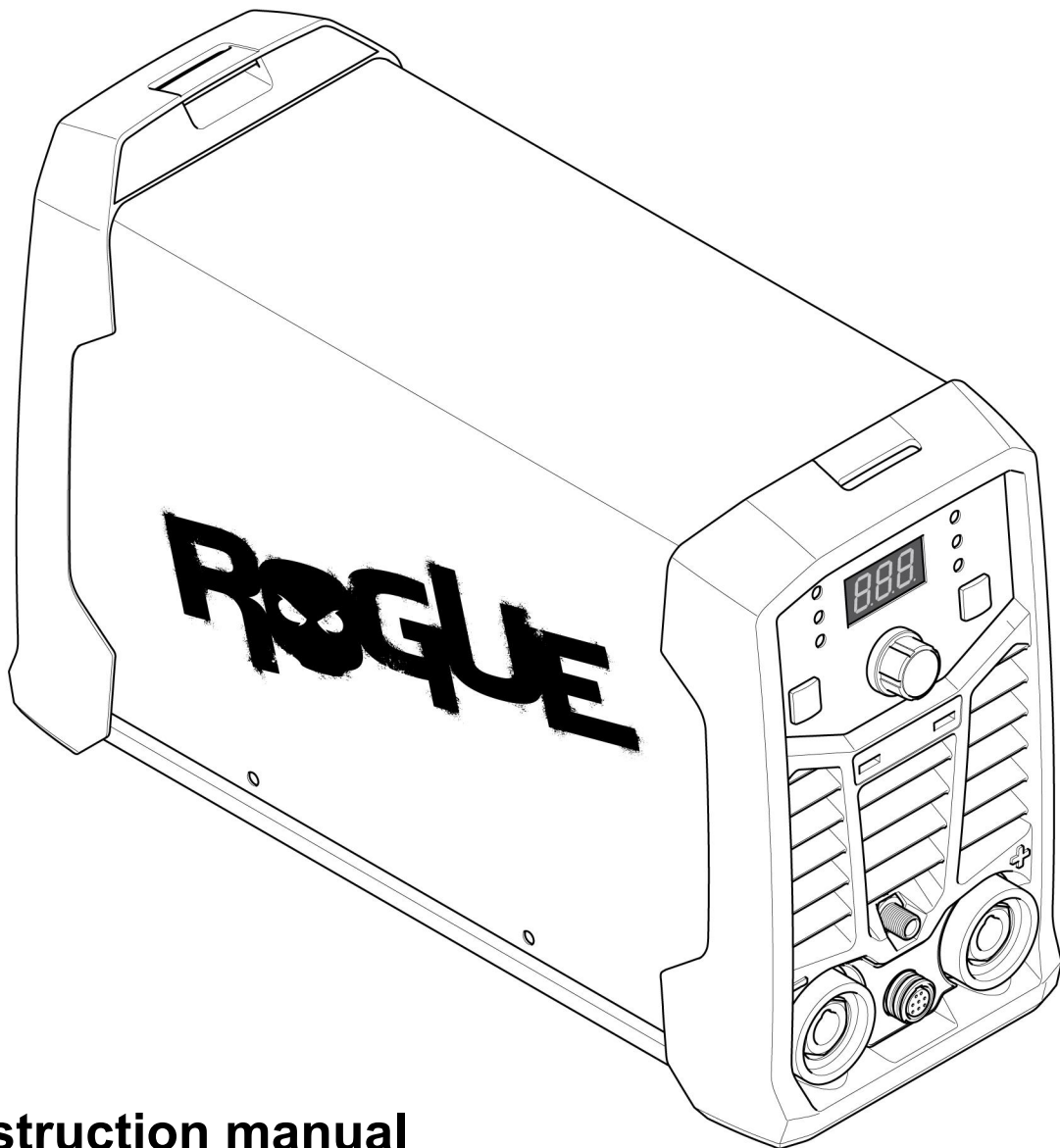

Rogue

# ***ET 200iP PRO***



**Instruction manual**

<b>1</b>	<b>SAFETY</b> .....	<b>3</b>
1.1	Meaning of symbols .....	3
1.2	Safety precautions .....	3
1.3	User responsibility .....	7
1.4	California Proposition 65 Warning.....	9
<b>2</b>	<b>INTRODUCTION</b> .....	<b>11</b>
2.1	Equipment .....	11
<b>3</b>	<b>TECHNICAL DATA</b> .....	<b>12</b>
<b>4</b>	<b>INSTALLATION</b> .....	<b>14</b>
4.1	Location.....	14
4.2	Lifting instructions .....	14
4.3	Main supply .....	15
<b>5</b>	<b>OPERATION</b> .....	<b>17</b>
5.1	Overview .....	17
5.2	Connections and control devices .....	17
5.3	Connecting welding and return cables .....	17
5.4	Turning the power on/off .....	18
5.5	Fan control .....	18
5.6	Thermal protection .....	18
5.7	Functions and symbols .....	18
5.8	Setting panel .....	20
5.9	Remote control .....	21
<b>6</b>	<b>MAINTENANCE</b> .....	<b>22</b>
6.1	Routine maintenance .....	22
6.2	Cleaning instructions.....	22
<b>7</b>	<b>TROUBLESHOOTING</b> .....	<b>24</b>
<b>8</b>	<b>ORDERING SPARE PARTS</b> .....	<b>25</b>
	<b>DIAGRAM</b> .....	<b>26</b>
	<b>ORDERING NUMBERS</b> .....	<b>27</b>
	<b>ACCESSORIES</b> .....	<b>28</b>

# 1 SAFETY

## 1.1 Meaning of symbols

As used throughout this manual: Means Attention! Be Alert!



### DANGER!

Means immediate hazards which, if not avoided, will result in immediate, serious personal injury or loss of life.



### WARNING!

Means potential hazards which could result in personal injury or loss of life.



### CAUTION!

Means hazards which could result in minor personal injury.



### WARNING!

Before use, read and understand the instruction manual and follow all labels, employer's safety practices and Safety Data Sheets (SDSs).



## 1.2 Safety precautions



### WARNING!

These Safety Precautions are for your protection. They summarise precautionary information from the references listed in Additional Safety Information section. Before performing any installation or operating procedures, be sure to read and follow the safety precautions listed below as well as all other manuals, material safety data sheets, labels, etc. Failure to observe Safety Precautions can result in injury or death.



### PROTECT YOURSELF AND OTHERS

Some welding, cutting and gouging processes are noisy and require hearing protection. The arc, like the sun, emits ultraviolet (UV) and other radiation and can injure the skin and eyes. Hot metal can cause burns. Training in the proper use of the processes and equipment is essential to prevent accidents. Therefore:

1. Wear a welding helmet fitted with a proper shade of filter to protect your face and eyes when welding or watching.
2. Always wear safety glasses with side shields in any work area, even if welding helmets, face shields and goggles are also required.
3. Use a face shield fitted with the correct filter and cover plates to protect your eyes, face, neck and ears from sparks and rays of the arc when operating or observing operations. Warn bystanders not to look at the arc and not to expose themselves to the rays of the electric-arc or hot metal.
4. Wear flameproof gauntlet-type gloves, heavy long-sleeve shirt, cuffless pants, high-topped shoes, and a welding helmet or cap for protection, to protect against arc rays and hot sparks or hot metal. A flameproof apron may also be desirable as protection against radiated heat and sparks.

5. Hot sparks or metal can lodge in rolled up sleeves, trouser cuffs, or pockets. Sleeves and collars should be kept buttoned and open pockets eliminated from the front of the clothing.
6. Protect other personnel from arc rays and hot sparks with a suitable non-flammable partition or curtains.
7. Use goggles over safety glasses when chipping slag or grinding. Chipped slag may be hot and can fly for long distances. Bystanders should also wear goggles over safety glasses.



### **FIRES AND EXPLOSIONS**

**The heat from flames and arcs can start fires. Hot slag or sparks can also cause fires and explosions. Therefore:**

1. Protect yourself and others from flying sparks and hot metal.
2. Move all combustible materials well away from the work area or cover the materials with a protective non-flammable covering. Combustible materials include wood, cloth, sawdust, liquid and gas fuels, solvents, paints, and coating paper, etc.
3. Hot sparks or hot metal can fall through cracks or crevices in floors or wall openings and cause a hidden smoldering fire or fires on the floor below. Make certain that such openings are protected from hot sparks and metal.
4. Do not weld, cut, or perform other hot work until the work piece has been completely cleaned so that there are no substances on the work piece which might produce flammable or toxic vapors. Do not perform hot work on closed containers, they may explode.
5. Have fire extinguishing equipment handy for instant use, such as a garden hose, water pail, sand bucket, or portable fire extinguisher. Be sure you are trained in its use.
6. Do not use equipment beyond its ratings. For example, an overloaded welding cable can overheat and create a fire hazard.
7. After completing work, inspect the work area to make sure there are no hot sparks or hot metal that could cause a fire later. Use fire watchers when necessary.



### **ELECTRICAL SHOCK**

**Contact between live electrical parts and earth can cause severe injury or death. DO NOT use AC welding current in damp areas, if movement is confined, or if there is danger of falling. Therefore:**

1. Be sure the power source frame (chassis) is connected to the earth system of the input power.
2. Connect the workpiece to a good electrical earth.
3. Connect the work cable to the workpiece. A poor or missing connection can expose you or others to a fatal shock.
4. Use well-maintained equipment. Replace worn or damaged cables.
5. Keep everything dry, including clothing, work area, cables, torch/electrode holder and power source.
6. Make sure that all parts of your body are insulated from both the work piece and from the ground.
7. Do not stand directly on metal or the ground while working in tight quarters or a damp area; stand on dry boards or an insulating platform and wear rubber-soled shoes.
8. Put on dry, hole-free gloves before turning on the power.
9. Turn off the power, before removing your gloves.
10. Refer to ANSI/ASC Standard Z49.1 for specific grounding recommendations. Do not mistake the work lead for a earth cable.



## ELECTRIC AND MAGNETIC FIELDS

**May be dangerous. Electric current flowing through any conductor causes localized Electric and Magnetic Fields (EMF). Welding and cutting current creates EMF around welding cables and welding machines. Therefore:**

1. Welders with pacemakers fitted should consult their doctor before welding. EMF may interfere with some pacemakers.
2. Exposure to EMF may have other health effects which are unknown.
3. Welders should use the following procedures to minimize exposure to EMF:
  - a) Route the electrode and work cables together. Secure them with tape when possible.
  - b) Never coil the torch or work cable around your body.
  - c) Do not place your body between the torch and work cables. Route cables on the same side of your body.
  - d) Connect the work cable to the workpiece as close as possible to the area being welded.
  - e) Keep the welding power source and cables as far away from your body as possible.



## FUMES AND GASES

**Fumes and gases, can cause discomfort or harm, particularly in confined spaces. Shielding gases can cause asphyxiation. Therefore:**

1. Keep your head out of the fumes. Do not breathe the fumes and gases.
2. Always provide adequate ventilation in the work area by natural or mechanical means. Do not weld, cut or gouge on materials such as galvanized steel, stainless steel, copper, zinc, lead beryllium or cadmium unless positive mechanical ventilation is provided. Do not breathe in the fumes from these materials.
3. Do not operate near degreasing and spraying operations. The heat or arc can react with chlorinated hydrocarbon vapors to form phosgene, a highly toxic gas, and other irritant gases.
4. If you develop momentary eye, nose or throat irritation while operating, this is an indication that the ventilation is not adequate. Stop work and take the necessary steps to improve ventilation in the work area. Do not continue to operate if physical discomfort persists.
5. Refer to ANSI/ASC Standard Z49.1 for specific ventilation recommendations.
6. **WARNING:** This product when used for welding or cutting, produces fumes or gases that contain chemicals known to the State of California to cause birth defects and in some cases cancer (California Health & Safety Code §25249.5 et seq.)



## CYLINDER HANDLING

**Cylinders, if mishandled, can rupture and violently release gas. A sudden rupture of cylinder valve or relief device can injure or kill. Therefore:**

1. Locate cylinders away from heat, sparks and flames. Never strike an arc on a cylinder.
2. Use the proper gas for the process and use the proper pressure reducing regulator designed to operate from the compressed gas cylinder. Do not use adapters. Maintain hoses and fittings in good condition. Follow the manufacturer's operating instructions for mounting a regulator to a compressed gas cylinder.

3. Always secure cylinders in an upright position, by chain or strap, to suitable hand trucks, undercarriages, benches, wall, post or racks. Never secure cylinders to work tables or fixtures where they may become part of an electrical circuit.
4. When not in use, keep cylinder valves closed. Have valve protection cap in place if regulator is not connected. Secure and move cylinders by using suitable hand trucks.



### MOVING PARTS

**Moving parts, such as fans, rotors and belts can cause injury. Therefore:**

1. Keep all doors, panels, guards, and covers closed and securely in place.
2. Stop the engine or drive systems before installing or connecting a unit.
3. Have only qualified people remove covers for maintenance and troubleshooting as necessary
4. To prevent accidental starting of equipment during service, disconnect negative (-) battery cable from battery.
5. Keep hands, hair, loose clothing and tools away from moving parts.
6. Reinstall panels or covers and close doors when service is finished and before starting engine.



#### **WARNING!**

#### **FALLING EQUIPMENT CAN INJURE**

- Only use lifting eye to lift unit. Do NOT use running gear, gas cylinders or any other accessories.
- Use equipment of adequate capacity to lift and support unit.
- If using lift forks to move unit, be sure forks are long enough to extend beyond opposite side of unit.
- Keep cables and cords away from moving vehicles when working from an aerial location.



#### **WARNING!**

#### **EQUIPMENT MAINTENANCE**

**Faulty or improperly maintained equipment can cause injury or death.**

**Therefore:**

1. Always have qualified personnel perform the installation, troubleshooting and maintenance work. Do not perform any electrical work unless you are qualified to perform such work.
2. Before performing any maintenance work inside a power source, disconnect the power source from the incoming electrical power.
3. Maintain cables, earthing wire, connections, power cord and power supply in safe working order. Do not operate any equipment in faulty condition.
4. Do not abuse any equipment or accessories. Keep equipment away from heat sources such as furnaces, wet conditions such as water puddles, oil or grease, corrosive atmospheres and inclement weather.
5. Keep all safety devices and cabinet covers in position and in good repair.
6. Use equipment only for its intended purpose. Do not modify it in any manner.

**CAUTION!****ADDITIONAL SAFETY INFORMATION**

**For more information on safe practices for electric arc welding and cutting equipment, ask your supplier for a copy of “Precautions and Safe Practices for Arc Welding, Cutting and Gouging.” Form 52-529.**

The following publications are recommended:

- ANSI/ASC Z49.1 - “Safety in Welding and Cutting”
- AWS C5.5 - “Recommended Practices for Gas Tungsten Arc Welding”
- AWS C5.6 - “Recommended Practices for Gas Metal Arc welding”
- AWS SP - “Safe practices” - Reprint, Welding Handbook
- ANSI/AWS F4.1 - “Recommended Safe Practices for Welding and Cutting of Containers That Have Held Hazardous Substances”
- OSHA 29 CFR 1910 - "Safety and health standards"
- CSA W117.2 - "Code for safety in welding and cutting"
- NFPA Standard 51B, “Fire Prevention During Welding, Cutting, and Other Hot Work”
- CGA Standard P-1, “Precautions for Safe Handling of Compressed Gases in Cylinders”
- ANSI Z87.1, "Occupational and Educational Personal Eye and Face Protection Devices"

### 1.3 User responsibility

Users of ESAB equipment have the ultimate responsibility for ensuring that anyone who works on or near the equipment observes all the relevant safety precautions. Safety precautions must meet the requirements that apply to this type of equipment. The following recommendations should be observed, in addition to the standard regulations that apply to the workplace.

All work must be carried out by trained personnel well-acquainted with the operation of the equipment. Incorrect operation of the equipment may lead to hazardous situations, which could result in injury to the operator and damage to the equipment.

1. Anyone who uses the equipment must be familiar with:
  - its operation
  - the location of emergency stops
  - its function
  - the relevant safety precautions
  - welding and cutting or other applicable operation of the equipment
2. The operator must ensure that:
  - no unauthorized person is within the working area of the equipment when it is started up
  - no-one is unprotected when the arc is struck or work is started with the equipment
3. The workplace must:
  - be suitable for the purpose
  - be free from drafts

4. Personal safety equipment:
  - Always wear recommended personal safety equipment, such as safety glasses, flame-proof clothing, safety gloves
  - Do not wear loose-fitting items, such as scarves, bracelets, rings, etc., which could become trapped or cause burns
5. General precautions:
  - Make sure the return cable is connected securely
  - Work on high voltage equipment **may only be carried out by a qualified electrician**
  - Appropriate fire extinguishing equipment must be clearly marked and close at hand
  - Lubrication and maintenance must **not** be carried out on the equipment during operation

### If equipped with ESAB cooler

Use ESAB approved coolant only. Non-approved coolant might damage the equipment and jeopardize product safety. In case of such damage, all warranty undertakings from ESAB cease to apply.

Recommended ESAB coolant ordering number: 0465 720 002.

For ordering information, see the "ACCESSORIES" chapter in the instruction manual.



#### WARNING!

Arc welding and cutting may cause injury to yourself and others. Take precautions when welding and cutting.



#### ELECTRIC SHOCK - Can kill

- Install and ground the unit in accordance with instruction manual.
- Do not touch live electrical parts or electrodes with bare skin, wet gloves, or wet clothing.
- Insulate yourself from work and ground.
- Ensure your working position is safe



#### ELECTRIC AND MAGNETIC FIELDS - Pose health risks

- Welders with pacemakers fitted should consult their doctor before welding. EMF may interfere with some pacemakers.
- Exposure to EMF may have other health effects which are unknown.
- Welders should use the following procedures to minimize exposure to EMF:
  - Route the electrode and work cables together on the same side of your body. Secure them with tape when possible. Do not place your body between the torch and work cables. Never coil the torch or work cable around your body. Keep the welding power source and cables as far away from your body as possible.
  - Connect the work cable to the workpiece as close as possible to the area being welded.



#### FUMES AND GASES - Can be dangerous to your health

- Keep your head out of the fumes.
- Use ventilation, extraction at the arc, or both, to take fumes and gases away from your breathing zone and the general area.





**ARC RAYS - Can injure eyes and burn skin**

- Protect your eyes and body. Use the correct welding screen and filter lens and wear protective clothing.
- Protect bystanders with suitable screens or curtains.



**NOISE - Excessive noise can damage hearing**

Protect your ears. Use ear defenders or other hearing protection.



**MOVING PARTS - Can cause injuries**

- Keep all doors, panels and covers closed and securely in place. Have only qualified people remove covers for maintenance and troubleshooting as necessary. Reinstall panels or covers and close doors when service is finished and before starting engine.
- Stop engine before installing or connecting unit.
- Keep hands, hair, loose clothing and tools away from moving parts.



**FIRE HAZARD**

- Sparks (spatter) can cause a fire. Make sure there are no inflammable materials nearby.
- Do not use on closed containers.



**HOT SURFACE - Parts can burn**

- Do not touch parts bare handed.
- Allow cooling period before working on equipment.
- To handle hot parts, use proper tools and/or insulated welding gloves to prevent burns.

**MALFUNCTION - Call for expert assistance in the event of malfunction.**

**PROTECT YOURSELF AND OTHERS!**



**WARNING!**

Do not use the power source for thawing frozen pipes.



**CAUTION!**

This product is solely intended for arc welding.

**ESAB has an assortment of welding accessories and personal protection equipment for purchase. For ordering information, contact your local ESAB dealer or visit us on our website.**

## 1.4 California Proposition 65 Warning



**WARNING!**

Welding or cutting equipment produces fumes or gases which contain chemicals known in the State of California to cause birth defects and, in some cases, cancer. (California Health & Safety Code Section 25249.5 et seq.)



**WARNING!**

This product can expose you to chemicals including lead, which are known to the state of California to cause cancer and birth defects or other reproductive harm. Wash hands after use.

For more information, go to [www.P65Warnings.ca.gov](http://www.P65Warnings.ca.gov).

## 2 INTRODUCTION

---

### Overview

**Rogue ET 200iP PRO** is an inverter-based power source intended for MMA (Manual Metal Arc), TIG (Tungsten Inert Gas) welding and HF TIG (High Frequency Tungsten Inert Gas) welding.

**ESAB accessories for the product can be found in the "ACCESSORIES" chapter of this manual.**

### 2.1 Equipment

**Rogue ET 200iP PRO** includes:

- Power Source
- Work Clamp Leadset
- Electrode Holder Leadset
- TIG Torch
- Gas Hose
- Gas Regulator
- Gas Outlet Adaptor
- Power Adaptor (120 V–230 V)
- Instruction Manual
- Quick Start Guide

### 3 TECHNICAL DATA

#### Technical data

<b>Rogue ET 200iP PRO (0700 500 073)</b>		
<b>Outlet voltage</b>	230 V $\pm$ 15% 1~ 50/60 Hz	120 V $\pm$ 15% 1~ 50/60 Hz
<b>Primary current</b>		
$I_{\max}$ MMA	30 A	25.7 A
$I_{\max}$ Live TIG	19.5 A	24 A
<b>No-load power</b> demand when in energy-saving mode	50 W	50 W
<b>Setting range</b>		
STICK	20–200 A	20–110 A
Live TIG	10–200 A	10–140 A
<b>Permissible load at MMA</b>		
25% duty cycle	200 A/28 V	110 A/24.4 V
60% duty cycle	129 A/25.2 V	70 A/22.8 V
100% duty cycle	100 A/24 V	55 A/22.2 V
<b>Permissible load at Live TIG</b>		
25% duty cycle	200 A/18 V	140 A/15.6 V
60% duty cycle	129 A/15.2 V	90 A/13.6 V
100% duty cycle	100 A/14 V	70 A/12.8 V
<b>Apparent power <math>I_2</math></b> at maximum current	6.9 kVA	3.3 kVA
<b>Active power <math>I_2</math></b> at maximum current	6.8 kW	3.26 kW
<b>Power factor</b> at maximum current		
Live TIG	0.99	0.99
STICK	0.99	0.99
<b>Efficiency</b> at maximum current		
STICK	82%	85%
Live TIG	82%	85%
<b>Open-circuit voltage <math>U_0</math> max</b>		
VRD 35 V deactivated	78 V	78 V
VRD 35 V activated	<30 V	<30 V
<b>Operating temperature</b>	+14 to +104 °F (-10 to +40 °C)	+14 to +104 °F (-10 to +40 °C)
<b>Transportation temperature</b>	32 to 104°F (-4 to +131 °F) (-20 to +55 °C)	32 to 104°F (-4 to +131 °F) (-20 to +55 °C)
<b>Continual sound pressure at no-load</b>	<70 dB	

	<b>Rogue ET 200iP PRO (0700 500 073)</b>
<b>Dimensions l × w × h</b>	15.9 × 6 × 10.4 in. (403×153×264 mm)
<b>Weight</b>	4.2 lbs (9.6 kg)
<b>Insulation class transformer</b>	H
<b>Enclosure class</b>	IP23S
<b>Application class</b>	<b>S</b>

**Duty cycle**

The duty cycle refers to the time as a percentage of a ten-minute period that you can weld or cut at a certain load without overloading. The duty cycle is valid for 104°F (40°C).

**Enclosure class**

The **IP** code indicates the enclosure class, i.e. the degree of protection against penetration by solid objects or water.

Equipment marked **IP23S** is intended for indoor and outdoor use; however, it should not be operated in precipitation.

**Application class**

The symbol **S** indicates that the power source is designed for use in areas with increased electrical hazard.

## 4 INSTALLATION

The installation must be carried out by a professional.



### CAUTION!

This product is intended for industrial use. In a domestic environment, this product may cause radio interference. It is the user's responsibility to take adequate precautions.

### 4.1 Location

Position the power source so that cooling air inlets and outlets are not obstructed.

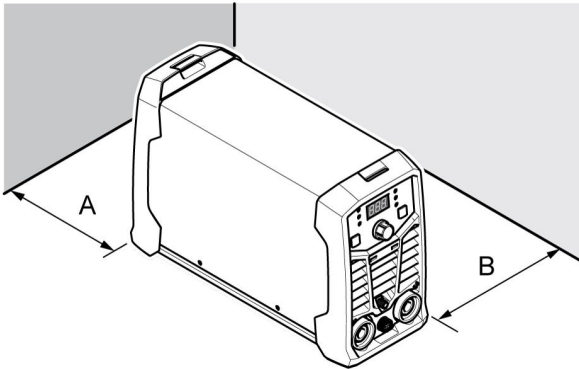

A. Minimum 200 mm (8 in.)

B. Minimum 200 mm (8 in.)



### WARNING!

Secure the equipment - particularly if the ground is uneven or sloping.

### 4.2 Lifting instructions

These units are equipped with a handle for carrying purposes.



### WARNING!

Electric shock can kill. Do not touch live electrical parts. Disconnect the input power conductors from the de-energized supply line before moving the welding power source.



### WARNING!

Falling equipment can cause serious personal injury and equipment damage.

Lift the unit with the handle on top of the case.

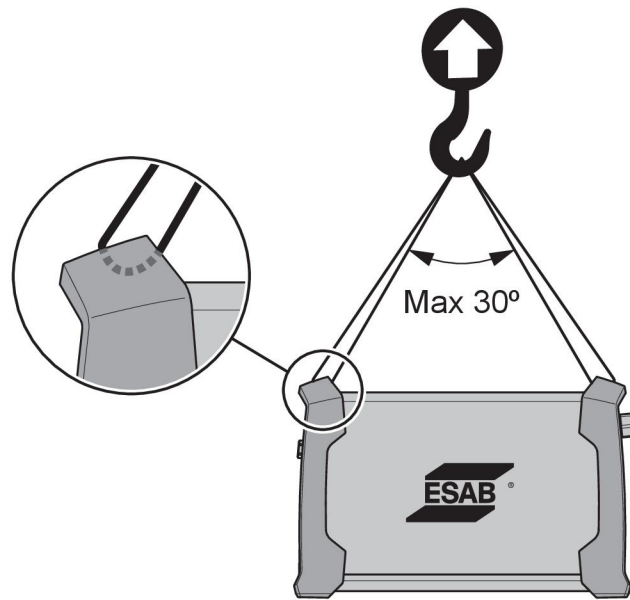

### 4.3 Main supply

The power source will automatically adjust to the supplied input voltage. Make sure that it is protected by the correct fuse rating. A protective ground connection must be made, in accordance with regulations.

1. Rating plate with supply connection data.

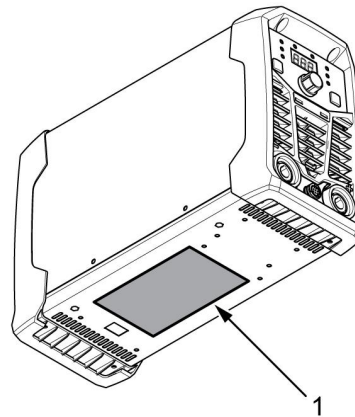

Recommended fuse sizes and minimum cable area for Rogue ET 200iP PRO		
<b>Supply voltage</b>	230 VAC	120 VAC
<b>Electrical cable area</b>	14 AWG, 2.0 mm <sup>2</sup>	14 AWG, 2.0 mm <sup>2</sup>
<b>Maximal current rating <math>I_{max}</math></b>		
MMA/Stick (SMAW)	30 A	25.7 A
<b><math>I_{1eff}</math> MMA/Stick (SMAW)</b>	15 A	14.5 A
<b>Fuse anti-surge type D MCB</b>	20 A	20 A
<b>Maximum recommended extension cord length</b>	328 ft (100 m)	328 ft (100 m)
<b>Minimum recommended extension cord size</b>	12 AWG, 3.3 mm <sup>2</sup>	12 AWG, 3.3 mm <sup>2</sup>



**NOTE!**

Different variants of the **Rogue ET 200iP PRO** are certified for different outlet voltages. Always refer to the rating plate for the specification of the power source in use.



**NOTE!**

Use the power source in accordance with the relevant national regulations.

For North American variants, the supplied adapter allows for connection of the power supply input cable plug to 120 V input power. Fitted plug is 50 A/240 V. Adapter is 15 A/120 V and 50 A/240 V.

**Supply from power generators**

The power source can be supplied from different types of generators. However, some generators may not provide sufficient power for the welding power source to operate correctly. Generators with Automatic Voltage Regulation (AVR) or with equivalent or better type of regulation, with rated power of 7 kW are recommended.



## 5 OPERATION

### 5.1 Overview

General safety regulations for handling the equipment can be found in the "SAFETY" chapter of this manual. Read it through before you start using the equipment!



#### NOTE!

When moving the equipment, use the handle. Never pull the cables.



#### WARNING!

Electric shock! Do not touch the workpiece or the welding head during operation!

### 5.2 Connections and control devices

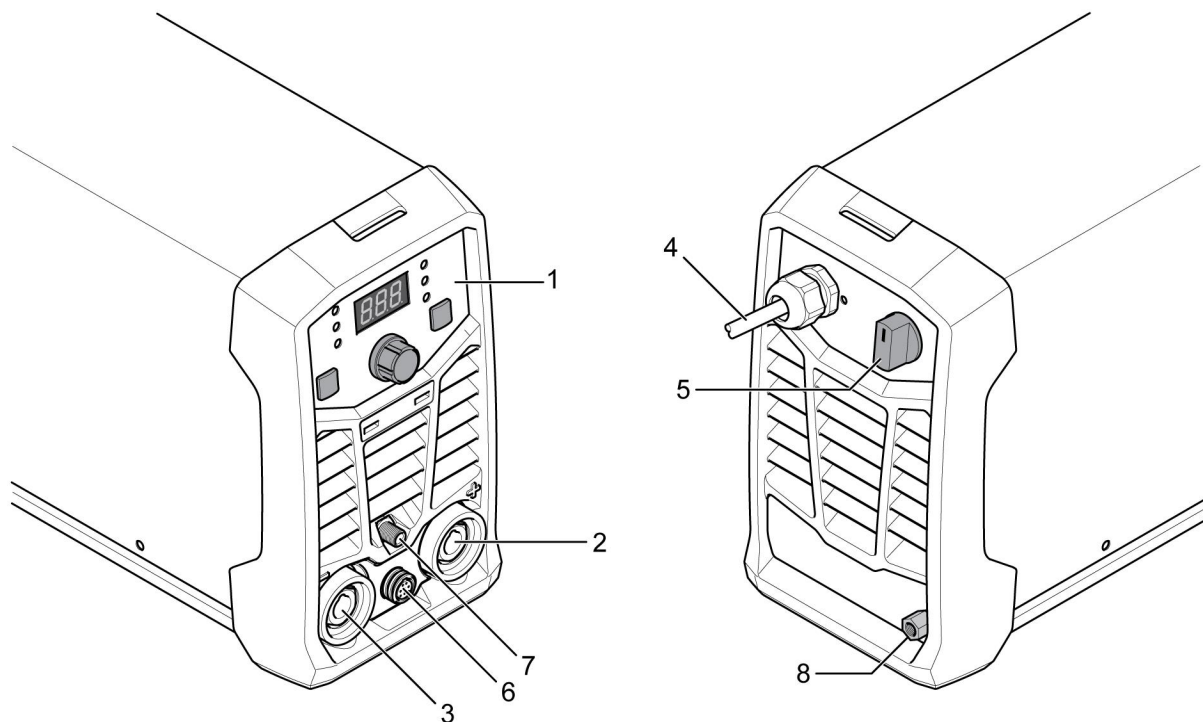

- |                              |                                   |
|------------------------------|-----------------------------------|
| 1. Setting panel             | 5. Mains power supply switch, I/O |
| 2. Positive welding terminal | 6. Remote socket                  |
| 3. Negative welding terminal | 7. Gas supply output              |
| 4. Power cable               | 8. Gas supply input               |

### 5.3 Connecting welding and return cables

The power source has two outputs, a positive welding terminal (+) and a negative welding terminal (-), for connecting welding and return cables. The output to which the welding cable is connected depends on the welding method or type of electrode used.

Connect the return cable to the other output on the power source. Secure the return cable's contact clamp to the workpiece, and make sure that there is a good contact between the workpiece and the output for the return cable on the power source.

- For TIG welding, the negative welding terminal (-) is used for the welding torch and the positive welding terminal (+) is used for the return cable.
- For MMA welding, the welding cable can be connected to the positive welding terminal (+) or negative welding terminal (-), depending on the type of electrode used. The connection polarity is stated on the electrode packaging.

## 5.4 Turning the power on/off

Turn on the power by turning the switch to the "ON" (I) position.

Turn the unit off by turning the switch to the "O" position.

Whether the power supply is interrupted or the power source is switched off in the normal manner, weld programs are stored so that they are available the next time the unit is started.



### CAUTION!

Do not turn off the power source during welding (with load).

## 5.5 Fan control

The **ET 200iP PRO** is fitted with a fan-as-needed feature. Fan-as-needed automatically switches the cooling fan off when it is not required. This has two main advantages; (1) to minimize power consumption, and (2) to minimize the amount of contaminants such as dust that are drawn into the power source.

Note that the fan will only operate when required for cooling purposes and will automatically switch off when not required.

## 5.6 Thermal protection



The power source includes thermal protection against overheating. When overheating occurs, welding stops, the overheating indicator on the panel illuminates, and an error message appears on the display screen. The protection is automatically reset once the temperature has decreased to a safe level.

## 5.7 Functions and symbols



### MMA welding

MMA welding may also be referred to as welding with coated electrodes. Striking the arc melts the electrode, and its coating forms protective slag.

For MMA welding the power source shall be supplemented with:

- welding cable with electrode holder
- Return cable with clamp

### Arc force

**Arc Force** The arc force function determines how the current changes in response to variations in arc length during welding. Use a low value of arc force to get a calm arc with little spatter and use a high value to get a hot and digging arc.

Arc force only applies to MMA welding.

### Hot start

**Hot Start** The hot start function temporarily increases the current in the beginning of the weld. Use this function to reduce the risk of insufficient fusion as well as electrode sticking and scratching.

Hot start only applies to MMA welding.



### TIG welding

TIG welding melts the metal of the workpiece, an arc initiated from a non-consuming tungsten electrode. The weld pool and electrode are protected by shielding gas.

For TIG welding, the welding power source shall be supplemented with:

- a TIG torch with gas valve
- an argon gas cylinder
- an argon gas regulator
- tungsten electrode

This power source performs **Live TIG start (TIG Live)**.

The tungsten electrode is placed against the workpiece. When lifted from workpiece, the arc is struck at a limited current level.

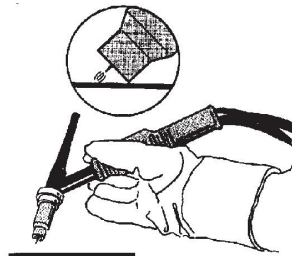
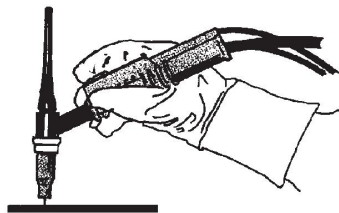

### HF start

The HF (High Frequency) start function strikes the arc by means of a spark from the tungsten electrode to the workpiece as the electrode is brought closer to the workpiece and the trigger on the TIG torch is pressed.

### Voltage Reduction Device (VRD)

**VRD** The VRD function ensures that the open-circuit voltage does not exceed 35 V when welding is not being carried out. This is indicated by a lit VRD indicator on the panel. Contact an authorized ESAB service technician to activate this function.

## 5.8 Setting panel

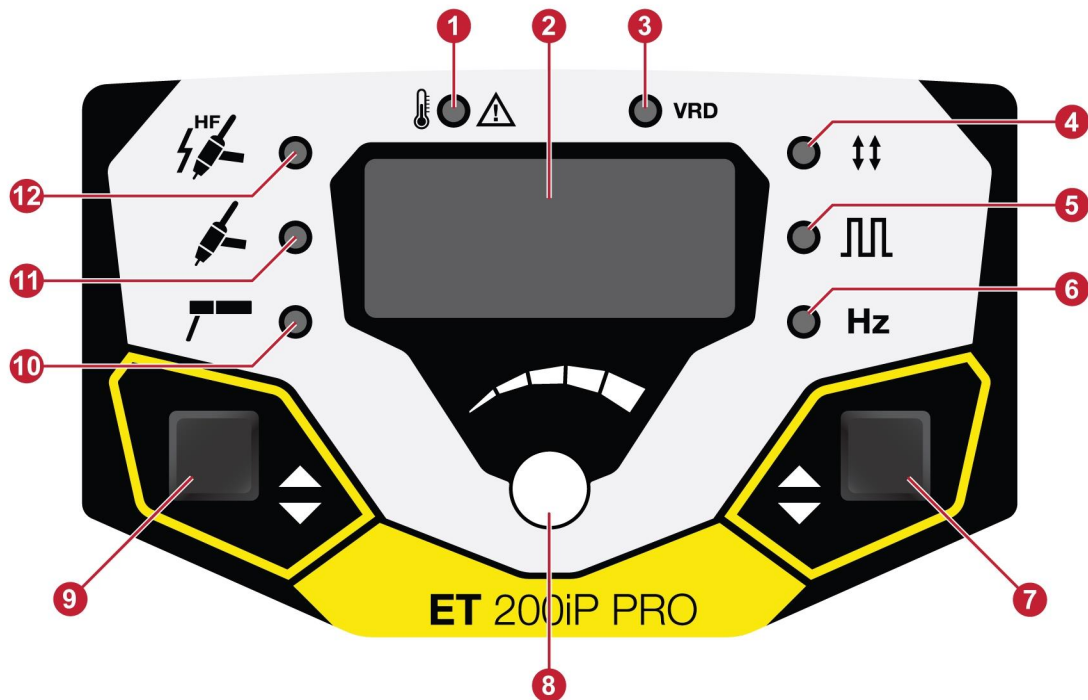

- |  |   |
|--|---|
| 1. Overheating indicator                                 | 7. Options button   |
| 2. Display   | 8. Welding current control knob and advanced feature control knob |
| 3. VRD function (reduced open-circuit voltage) indicator | 9. Process selection button                                       |
| 4. Trigger mode indicator                                | 10. MMA indicator   |
| 5. Pulse mode indicator                                  | 11. TIG Live indicator  |
| 6. Frequency indicator                                   | 12. TIG HF indicator  |

Press the Process selection button (9) to set the following:

- TIG HF (12)
- TIG Live (11)
- MMA (10)
- Navigation
- Parameter selection

Press the Process selection button (9) for 3 sec to go to the advanced feature menu and press the Process selection button (9) to select the values. Use the Welding current control knob (8) to change the values.

In TIG HF or TIG Live mode:

- Gas pre-flow time (PREG 0–5 s)
- Start current (IGNA 10–100%)
- Up slope time (SLPU 0–10 s)
- Down slope time (SLPD 0–10 s)
- End current (FINA 10–100%)
- Gas post-flow time (POSG 0.5–15 s)
- Background current (BKGA 10–100%)

In MMA mode:

- Hot start (HOTS -10 – +10)
- Arc force (ARCF -10 – +10)
- Cellulose electrode (CELL On/Off)

Press the Options button (7) to set the following:

- Trigger mode (4): 2 stroke/4 stroke
- Pulse mode (5): (On/Off)
- Frequency (6): (0.2–500 Hz) — only if Pulse mode is ON.

### **5.9 Remote control**

Connect the remote control to the front of the power source. When the remote control is connected, it is automatically activated. The maximum setting of the power source will be determined by the respective front panel control, irrespective of the remote control device setting.

## 6 MAINTENANCE



### WARNING!

The mains supply must be disconnected during cleaning and maintenance.



### CAUTION!

Only persons with appropriate electrical knowledge (authorized personnel) may remove the safety plates.



### CAUTION!

The product is covered by a manufacturer's warranty. Any attempt to carry out repair work by unauthorized service centers or personnel will invalidate the warranty.



### NOTE!

Regular maintenance is important for safe and reliable operation.



### NOTE!





Perform maintenance more often during severe dusty conditions.

Before each use, make sure that the:

- Product and cables are undamaged, and
- The torch is clean and undamaged.

### 6.1 Routine maintenance

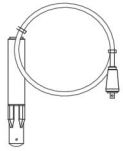
Maintenance schedule during normal conditions. Check equipment before every use.

Interval	Area to maintain		
Every 3 months	 Clean or replace unreadable labels.	 Clean weld terminals.	 Check or replace weld cables.
Every 6 months	 Clean inside equipment. Use dry compressed air with reduced pressure.		

### 6.2 Cleaning instructions

To maintain the performance and increase the lifetime of the power source, it is mandatory to clean it regularly. How often depends on:

- The welding process,
- The arc time, and
- The working environment.



**CAUTION!**

Make sure that the cleaning procedure is done in a suitable prepared workspace.



**CAUTION!**

During cleaning, always wear the recommended personal protective equipment, such as earplugs, safety glasses, masks, gloves and safety shoes.

1. Disconnect the power source from the power supply.
2. Open the enclosure and use a vacuum cleaner to remove any accumulated dirt, metal filings, slag and loose material. Keep the shunt and lead screw surfaces clean as accumulated foreign material may reduce the welder's output welding current.

## 7 TROUBLESHOOTING

Perform these checks and inspections before contacting an authorized service technician.

- Check that power is disconnected before starting any type of repair action.

Type of fault	Corrective action
MMA welding problems	Check that the welding process is set for MMA.
	Check that the welding and return cables are correctly connected to the power source.
	Make sure that the return clamp has good contact with the workpiece.
	Check that the correct electrodes and polarity are being used. For polarity, check electrode packaging.
	Check that the correct Welding current (A) is set.
	Adjust Arc Force and Hot start.
TIG welding problems	Check that the welding process is set for Live TIG as necessary.
	Check that the TIG torch and return cables are correctly connected to the power source.
	Make sure that the return clamp has good contact with the workpiece.
	Make sure that the TIG torch lead is connected to the negative welding terminal.
	Make sure that the correct shielding gas, gas flow, welding current, filler rod placement, electrode diameter and welding mode on the power source are used.
No arc	Check that the electrical power supply switch is turned on.
	Check that the display is on to verify that the power source has power.
	Check that the setting panel is displaying the correct values.
	Check that the welding and return cables are correctly connected.
	Check the electrical power supply fuses.
Welding current is interrupted during welding	Check whether the Over Temperature LED (Thermal Protection) on the setting panel is on.
	Continue with Troubleshooting "No Arc."
Thermal protection trips frequently	Make sure that the recommended duty cycle for the weld current has not been exceeded.
	Refer to power source "Duty cycle" section in the TECHNICAL DATA chapter.
	Make sure that the air inlets or outlets are not clogged.
	Clean the inside of the machine using routine maintenance methods.



## 8 ORDERING SPARE PARTS

---



### CAUTION!

Repair and electrical work should be performed by an authorised ESAB service technician. Use only ESAB original spare and wear parts.

The **Rogue ET 200iP PRO** is designed and tested in accordance with the international standards **CSA E60974-1** and **ANSI/IEC 60974-1**. Upon completion of service or repair work, it is the responsibility of the person(s) performing the work to ensure that the product still complies with the requirements of the above standards.

Spare parts and wear parts can be ordered through your nearest ESAB dealer, see [esab.com](http://esab.com). When ordering, please state product type, serial number, designation and spare part number in accordance with the spare parts list. This facilitates dispatch and ensures correct delivery.

# DIAGRAM

From serial number HA027-xxxx-xxxx

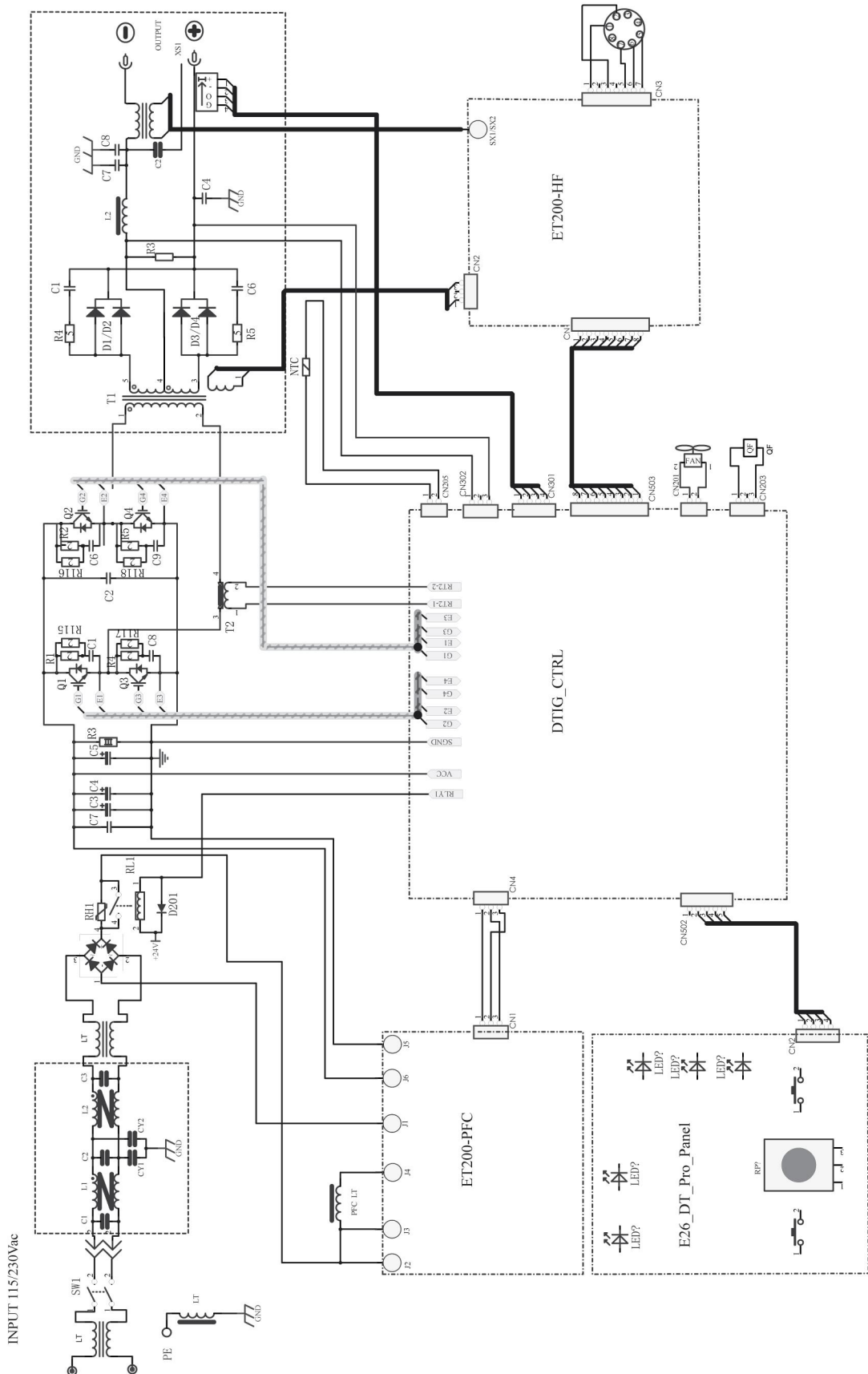

---

**ORDERING NUMBERS**

---

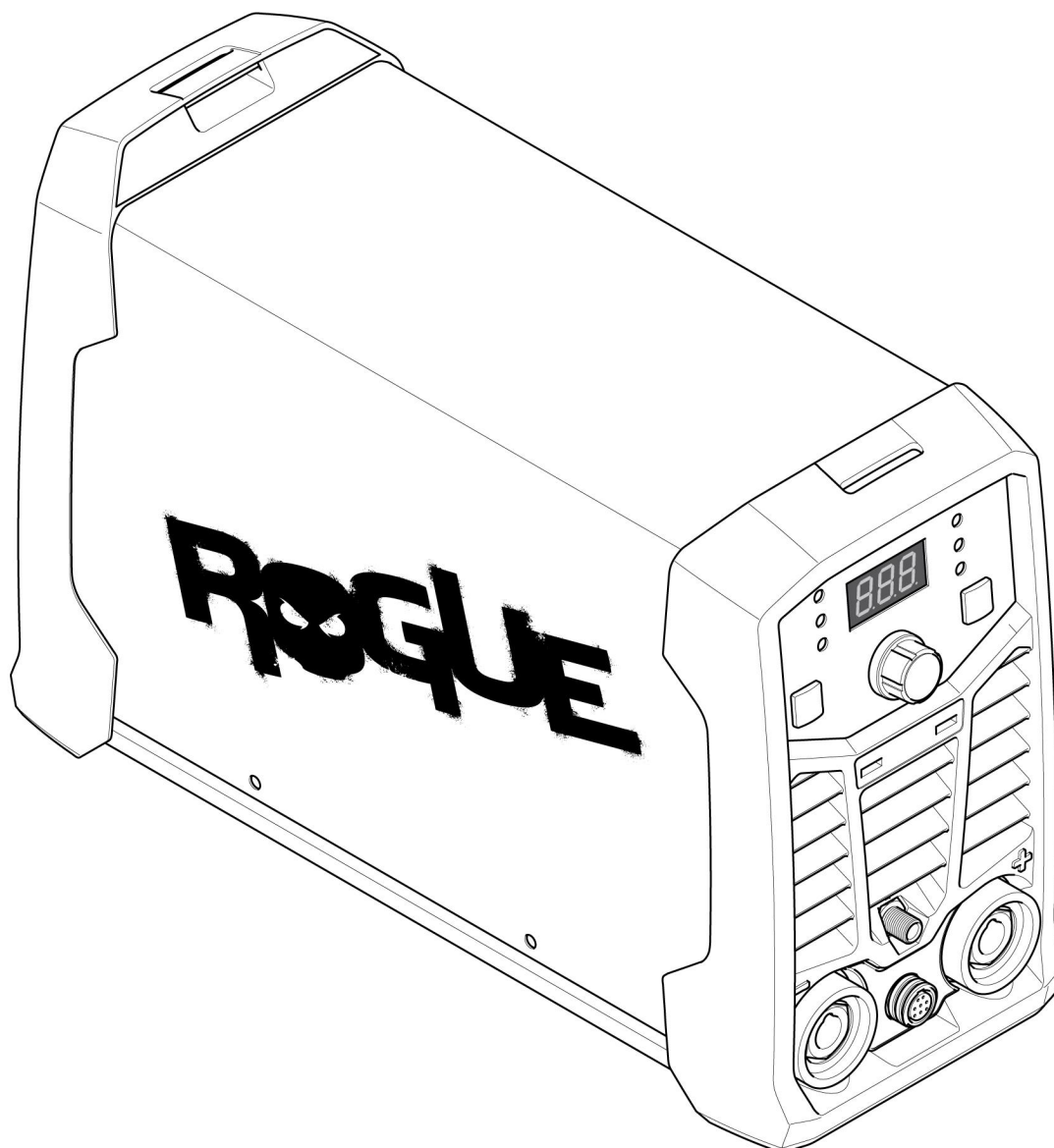

Ordering number	Denomination	Type	Notes
0700 500 073	Power source	Rogue ET 200iP PRO	NOAM
0463 711 *	Instruction manual		

Technical documentation is available on the Internet at: [www.esab.com](http://www.esab.com)

The three last digits in the document number of the manual show the version of the manual. Therefore they are replaced with \* here. Make sure to use a manual with a serial number or software version that corresponds with the product, see the front page of the manual.

## ACCESSORIES

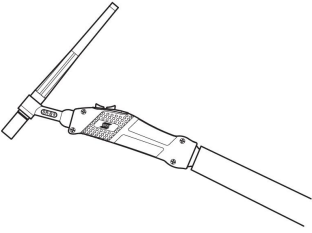
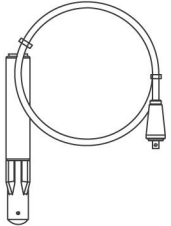
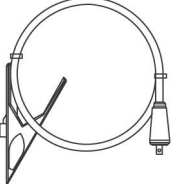
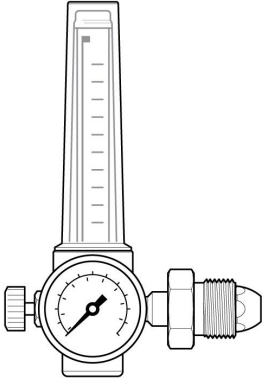
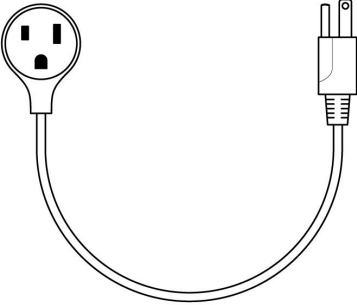
TIG torches		
16X48	HW 17 60 DEG, 3.5 m	
0700 025 557	TIG Torch, SR-B 26FX-R, 4 m, Remote	
0700 025 591	TIG Torch, SR-B 26FX-R, 8 m, Remote	
WS200E13	Electrode holder, 200 A and lead assembly, 4 m (13 ft), 50 mm	
WS200G10	Ground clamp, 200 A and lead assembly, 3 m (10 ft), 50 mm	
0781-2701 GRF400-580	Regulator flow meter	
W4014000	Power adapter	

ACCESSORIES

0700 500 086	Shoulder strap	
W4014450	Foot pedal, 8 PIN	



# A WORLD OF PRODUCTS AND SOLUTIONS.



For contact information visit [esab.com](http://esab.com)

ESAB AB, Lindholmsallén 9, Box 8004, 402 77 Gothenburg, Sweden, Phone +46 (0) 31 50 90 00

<http://manuals.esab.com>

