



EMP 205ic AC/DC



Instruction manual

1	SAFETY	5
1.1	Meaning of symbols	5
1.2	Safety precautions	5
1.3	User responsibility	9
1.4	California Proposition 65 Warning	11
2	INTRODUCTION	12
2.1	Equipment	12
2.2	Overheating protection	12
3	TECHNICAL DATA	13
3.1	EMP 205ic AC/DC specifications	13
4	INSTALLATION	16
4.1	Location	16
4.2	High frequency interference	16
4.2.1	User's responsibility	17
4.2.2	Assessment of area	17
4.3	Lifting instructions	18
4.4	Mains supply	19
4.5	Recommended electrical-supply specifications	20
4.6	Supply from power generators	20
5	OPERATION	21
5.1	Connections and controls	22
5.2	Connection of welding and return cables	23
5.2.1	For MIG/MMA process	23
5.2.2	For TIG process	23
5.3	Polarity change	24
5.4	Shielding gas	24
5.5	Volt-ampere curves	24
5.5.1	SMAW (Stick) 120 V	25
5.5.2	SMAW (Stick) 230 V	25
5.5.3	GMAW (MIG) 120 V	26
5.5.4	GMAW (MIG) 230 V	26
5.5.5	GTAW (DC TIG) 120 V	27
5.5.6	GTAW (DC TIG) 230 V	27
5.5.7	GTAW (AC TIG) 120 V	28
5.5.8	GTAW (AC TIG) 230 V	28
5.5.9	Duty cycle	29
5.5.9.1	25% duty cycle	29
5.6	Removing/installing bobbin	30
5.7	Removing/installing wire	30
5.7.1	Removing wire	32
5.7.2	Installing wire	34

5.8	Welding with aluminum wire	35
5.9	Setting wire-feed pressure	35
5.10	Removing/installing wire-feed roller	36
5.10.1	Removing wire-feed roller	37
5.10.2	Installing wire-feed roller	39
6	CONTROL PANEL	40
6.1	How to navigate	40
6.2	Main menu	40
6.3	sMIG mode: Basic	40
6.4	sMIG mode: Advanced	41
6.5	Manual MIG mode: Basic	41
6.6	Manual MIG mode: Advanced	41
6.7	Flux cored wire mode: Basic	41
6.8	Flux cored wire mode: Advanced	42
6.9	MMA mode: Basic	42
6.10	MMA mode: Advanced	42
6.11	DC TIG mode: Basic	42
6.12	DC TIG mode: Advanced	43
6.13	AC TIG mode: Basic	43
6.14	AC TIG mode: Advanced	43
6.15	Settings	43
6.16	User manual information	44
6.17	Icon reference guide	44
6.18	DC TIG Pulse	47
6.19	AC TIG Welding	49
6.20	Lift-TIG welding	52
7	MAINTENANCE	54
7.1	Routine maintenance	54
7.2	Wire-feeder assembly maintenance	55
7.2.1	Wire-feeder assembly cleaning	55
7.3	EMP-unit power side maintenance	56
7.4	Torch liner maintenance	57
7.4.1	Torch liner cleaning	57
8	TROUBLESHOOTING	58
8.1	Preliminary checks	58
8.2	User interface (UI) software displayed error codes	60
9	ORDERING SPARE PARTS	61
	DIAGRAM	62
	ORDERING NUMBERS	63
	WEAR PARTS	64
	ACCESSORIES	65

TABLE OF CONTENTS

REPLACEMENTS PARTS..... **66**
ROLLER & WIRE-GUIDE SELECTION **67**

1 SAFETY

1.1 Meaning of symbols

As used throughout this manual: Means Attention! Be Alert!



DANGER!

Means immediate hazards which, if not avoided, will result in immediate, serious personal injury or loss of life.



WARNING!

Means potential hazards which could result in personal injury or loss of life.



CAUTION!

Means hazards which could result in minor personal injury.



WARNING!

Before use, read and understand the instruction manual and follow all labels, employer's safety practices and Safety Data Sheets (SDSs).



1.2 Safety precautions



WARNING!

These Safety Precautions are for your protection. They summarise precautionary information from the references listed in Additional Safety Information section. Before performing any installation or operating procedures, be sure to read and follow the safety precautions listed below as well as all other manuals, material safety data sheets, labels, etc. Failure to observe Safety Precautions can result in injury or death.



PROTECT YOURSELF AND OTHERS

Some welding, cutting and gouging processes are noisy and require hearing protection. The arc, like the sun, emits ultraviolet (UV) and other radiation and can injure the skin and eyes. Hot metal can cause burns. Training in the proper use of the processes and equipment is essential to prevent accidents. Therefore:

1. Wear a welding helmet fitted with a proper shade of filter to protect your face and eyes when welding or watching.
2. Always wear safety glasses with side shields in any work area, even if welding helmets, face shields and goggles are also required.
3. Use a face shield fitted with the correct filter and cover plates to protect your eyes, face, neck and ears from sparks and rays of the arc when operating or observing operations. Warn bystanders not to look at the arc and not to expose themselves to the rays of the electric-arc or hot metal.

4. Wear flameproof gauntlet-type gloves, heavy long-sleeve shirt, cuffless pants, high-topped shoes, and a welding helmet or cap for protection, to protect against arc rays and hot sparks or hot metal. A flameproof apron may also be desirable as protection against radiated heat and sparks.
5. Hot sparks or metal can lodge in rolled up sleeves, trouser cuffs, or pockets. Sleeves and collars should be kept buttoned and open pockets eliminated from the front of the clothing.
6. Protect other personnel from arc rays and hot sparks with a suitable non-flammable partition or curtains.
7. Use goggles over safety glasses when chipping slag or grinding. Chipped slag may be hot and can fly for long distances. Bystanders should also wear goggles over safety glasses.



FIRES AND EXPLOSIONS

The heat from flames and arcs can start fires. Hot slag or sparks can also cause fires and explosions. Therefore:

1. Protect yourself and others from flying sparks and hot metal.
2. Move all combustible materials well away from the work area or cover the materials with a protective non-flammable covering. Combustible materials include wood, cloth, sawdust, liquid and gas fuels, solvents, paints, and coating paper, etc.
3. Hot sparks or hot metal can fall through cracks or crevices in floors or wall openings and cause a hidden smoldering fire or fires on the floor below. Make certain that such openings are protected from hot sparks and metal.
4. Do not weld, cut, or perform other hot work until the work piece has been completely cleaned so that there are no substances on the work piece which might produce flammable or toxic vapors. Do not perform hot work on closed containers, they may explode.
5. Have fire extinguishing equipment handy for instant use, such as a garden hose, water pail, sand bucket, or portable fire extinguisher. Be sure you are trained in its use.
6. Do not use equipment beyond its ratings. For example, an overloaded welding cable can overheat and create a fire hazard.
7. After completing work, inspect the work area to make sure there are no hot sparks or hot metal that could cause a fire later. Use fire watchers when necessary.



ELECTRICAL SHOCK

Contact between live electrical parts and earth can cause severe injury or death. DO NOT use AC welding current in damp areas, if movement is confined, or if there is danger of falling. Therefore:

1. Be sure the power source frame (chassis) is connected to the earth system of the input power.
2. Connect the workpiece to a good electrical earth.
3. Connect the work cable to the workpiece. A poor or missing connection can expose you or others to a fatal shock.
4. Use well-maintained equipment. Replace worn or damaged cables.
5. Keep everything dry, including clothing, work area, cables, torch/electrode holder and power source.
6. Make sure that all parts of your body are insulated from both the work piece and from the ground.
7. Do not stand directly on metal or the ground while working in tight quarters or a damp area; stand on dry boards or an insulating platform and wear rubber-soled shoes.

8. Put on dry, hole-free gloves before turning on the power.
9. Turn off the power, before removing your gloves.
10. Refer to ANSI/ASC Standard Z49.1 for specific grounding recommendations. Do not mistake the work lead for a earth cable.



ELECTRIC AND MAGNETIC FIELDS

May be dangerous. Electric current flowing through any conductor causes localized Electric and Magnetic Fields (EMF). Welding and cutting current creates EMF around welding cables and welding machines. Therefore:

1. Welders having pacemakers should consult their physician before welding. EMF may interfere with some pacemakers.
2. Exposure to EMF may have other health effects which are unknown.
3. Welders should use the following procedures to minimise exposure to EMF:
 - a) Route the electrode and work cables together. Secure them with tape when possible.
 - b) Never coil the torch or work cable around your body.
 - c) Do not place your body between the torch and work cables. Route cables on the same side of your body.
 - d) Connect the work cable to the workpiece as close as possible to the area being welded.
 - e) Keep welding power source and cables as far away from your body as possible.



FUMES AND GASES

Fumes and gases, can cause discomfort or harm, particularly in confined spaces. Shielding gases can cause asphyxiation. Therefore:

1. Keep your head out of the fumes. Do not breathe the fumes and gases.
2. Always provide adequate ventilation in the work area by natural or mechanical means. Do not weld, cut or gouge on materials such as galvanized steel, stainless steel, copper, zinc, lead beryllium or cadmium unless positive mechanical ventilation is provided. Do not breathe in the fumes from these materials.
3. Do not operate near degreasing and spraying operations. The heat or arc can react with chlorinated hydrocarbon vapors to form phosgene, a highly toxic gas, and other irritant gases.
4. If you develop momentary eye, nose or throat irritation while operating, this is an indication that the ventilation is not adequate. Stop work and take the necessary steps to improve ventilation in the work area. Do not continue to operate if physical discomfort persists.
5. Refer to ANSI/ASC Standard Z49.1 for specific ventilation recommendations.
6. **WARNING:** This product when used for welding or cutting, produces fumes or gases that contain chemicals known to the State of California to cause birth defects and in some cases cancer (California Health & Safety Code §25249.5 et seq.)



CYLINDER HANDLING

Cylinders, if mishandled, can rupture and violently release gas. A sudden rupture of cylinder valve or relief device can injure or kill. Therefore:

1. Locate cylinders away from heat, sparks and flames. Never strike an arc on a cylinder.
2. Use the proper gas for the process and use the proper pressure reducing regulator designed to operate from the compressed gas cylinder. Do not use adapters. Maintain hoses and fittings in good condition. Follow the manufacturer's operating instructions for mounting a regulator to a compressed gas cylinder.
3. Always secure cylinders in an upright position, by chain or strap, to suitable hand trucks, undercarriages, benches, wall, post or racks. Never secure cylinders to work tables or fixtures where they may become part of an electrical circuit.
4. When not in use, keep cylinder valves closed. Have valve protection cap in place if regulator is not connected. Secure and move cylinders by using suitable hand trucks.



MOVING PARTS

Moving parts, such as fans, rotors and belts can cause injury. Therefore:

1. Keep all doors, panels, guards, and covers closed and securely in place.
2. Stop the engine or drive systems before installing or connecting a unit.
3. Have only qualified people remove covers for maintenance and troubleshooting as necessary
4. To prevent accidental starting of equipment during service, disconnect negative (-) battery cable from battery.
5. Keep hands, hair, loose clothing and tools away from moving parts.
6. Reinstall panels or covers and close doors when service is finished and before starting engine.



WARNING!

FALLING EQUIPMENT CAN INJURE

- Do NOT use running gear, gas cylinders or any other accessories.
- Use equipment of adequate capacity to lift and support unit.
- Keep cables and cords away from moving vehicles when working from an aerial location.



WARNING!

EQUIPMENT MAINTENANCE

Faulty or improperly maintained equipment can cause injury or death.

Therefore:

1. Always have qualified personnel perform the installation, troubleshooting and maintenance work. Do not perform any electrical work unless you are qualified to perform such work.
2. Before performing any maintenance work inside a power source, disconnect the power source from the incoming electrical power.
3. Maintain cables, earthing wire, connections, power cord and power supply in safe working order. Do not operate any equipment in faulty condition.
4. Do not abuse any equipment or accessories. Keep equipment away from heat sources such as furnaces, wet conditions such as water puddles, oil or grease, corrosive atmospheres and inclement weather.
5. Keep all safety devices and cabinet covers in position and in good repair.
6. Use equipment only for its intended purpose. Do not modify it in any manner.

**CAUTION!****ADDITIONAL SAFETY INFORMATION**

For more information on safe practices for electric arc welding and cutting equipment, ask your supplier for a copy of “Precautions and Safe Practices for Arc Welding, Cutting and Gouging.” Form 52-529.

The following publications are recommended to you:

1. ANSI/ASC Z49.1 - “Safety in Welding and Cutting”
2. AWS C5.5 - “Recommended Practices for Gas Tungsten Arc Welding”
3. AWS C5.6 - “Recommended Practices for Gas Metal Arc welding”
4. AWS SP - “Safe practices” - Reprint, Welding Handbook
5. ANSI/AWS F4.1 - “Recommended Safe Practices for Welding and Cutting of Containers That Have Held Hazardous Substances”
6. OSHA 29 CFR 1910 - "Safety and health standards"
7. CSA W117.2 - "Code for safety in welding and cutting"
8. NFPA Standard 51B, “Fire Prevention During Welding, Cutting, and Other Hot Work”
9. CGA Standard P-1, “Precautions for Safe Handling of Compressed Gases in Cylinders”
10. ANSI Z87.1, "Occupational and Educational Personal Eye and Face Protection Devices"

1.3 User responsibility

Users of ESAB equipment have the ultimate responsibility for ensuring that anyone who works on or near the equipment observes all the relevant safety precautions. Safety precautions must meet the requirements that apply to this type of equipment. The following recommendations should be observed, in addition to the standard regulations that apply to the workplace.

All work must be carried out by trained personnel well-acquainted with the operation of the equipment. Incorrect operation of the equipment may lead to hazardous situations, which could result in injury to the operator and damage to the equipment.

1. Anyone who uses the equipment must be familiar with:
 - its operation
 - the location of emergency stops
 - its function
 - the relevant safety precautions
 - welding and cutting or other applicable operation of the equipment
2. The operator must ensure that:
 - no unauthorized person is within the working area of the equipment when it is started up
 - no-one is unprotected when the arc is struck or work is started with the equipment
3. The workplace must:
 - be suitable for the purpose
 - be free from drafts

4. Personal safety equipment:
 - Always wear recommended personal safety equipment, such as safety glasses, flame-proof clothing, safety gloves
 - Do not wear loose-fitting items, such as scarves, bracelets, rings, etc., which could become trapped or cause burns
5. General precautions:
 - Make sure the return cable is connected securely
 - Work on high voltage equipment **may only be carried out by a qualified electrician**
 - Appropriate fire extinguishing equipment must be clearly marked and close at hand
 - Lubrication and maintenance must **not** be carried out on the equipment during operation

**WARNING!**

Arc welding and cutting may cause injury to yourself and others. Take precautions when welding and cutting.

**ELECTRIC SHOCK - Can kill**

- Install and ground the unit in accordance with instruction manual.
- Do not touch live electrical parts or electrodes with bare skin, wet gloves, or wet clothing.
- Insulate yourself from work and ground.
- Ensure your working position is safe

**ELECTRIC AND MAGNETIC FIELDS - Pose health risks**

- Welders with pacemakers fitted should consult their doctor before welding. EMF may interfere with some pacemakers.
- Exposure to EMF may have other health effects which are unknown.
- Welders should use the following procedures to minimize exposure to EMF:
 - Route the electrode and work cables together on the same side of your body. Secure them with tape when possible. Do not place your body between the torch and work cables. Never coil the torch or work cable around your body. Keep the welding power source and cables as far away from your body as possible.
 - Connect the work cable to the workpiece as close as possible to the area being welded.

**FUMES AND GASES - Can be dangerous to your health**

- Keep your head out of the fumes.
- Use ventilation, extraction at the arc, or both, to take fumes and gases away from your breathing zone and the general area.

**ARC RAYS - Can injure eyes and burn skin**

- Protect your eyes and body. Use the correct welding screen and filter lens and wear protective clothing.
- Protect bystanders with suitable screens or curtains.

**NOISE - Excessive noise can damage hearing**

Protect your ears. Use ear defenders or other hearing protection.

MOVING PARTS - Can cause injuries



- Keep all doors, panels and covers closed and securely in place. Have only qualified people remove covers for maintenance and troubleshooting as necessary. Reinstall panels or covers and close doors when service is finished and before starting engine.



- Stop engine before installing or connecting unit.
- Keep hands, hair, loose clothing and tools away from moving parts.

FIRE HAZARD



- Sparks (spatter) can cause a fire. Make sure there are no inflammable materials nearby.
- Do not use on closed containers.

MALFUNCTION - Call for expert assistance in the event of malfunction.

PROTECT YOURSELF AND OTHERS!



WARNING!

Do not use the power source for thawing frozen pipes.



CAUTION!

This product is solely intended for arc welding.

ESAB has an assortment of welding accessories and personal protection equipment for purchase. For ordering information, contact your local ESAB dealer or visit us on our website.

1.4 California Proposition 65 Warning



WARNING!

Welding or cutting equipment produces fumes or gases that contain chemicals known in the State of California to cause birth defects and, in some cases, cancer. (California Health & Safety Code Section 25249.5 et seq.)



WARNING!

This product contains chemicals, including lead, known to the State of California to cause cancer, birth defects, or other reproductive harm. Wash hands after use.

2 INTRODUCTION

The ESAB EMP 205ic AC/DC product is a new generation of multi-process (MIG/Stick/TIG: AC or DC) welding power sources.

All Rebel power sources are designed to match the needs of the user. They are tough, durable, and portable, providing excellent arc performance across a variety of welding applications.

The EMP family features a 4.3 in. (11 cm) color TFT (Thin Film Transistor) user interface (UI) display which provides quick and easy selection of weld process and parameters, suitable for both newly trained and intermediate-level users. For more advanced users, any number of functions could be introduced and customized to give maximum flexibility.

ESAB accessories for the product can be found in the "ACCESSORIES" chapter of this manual.

2.1 Equipment

The ESAB EMP 205ic AC/DC power source is supplied with:

- Tweco® Fusion™ 180 A MIG torch with Bonus Tweco® Contact Tips
- ESAB Heliarc HW 17 TIG Torch with Accessories
- Tweco® 200 Amp Electrode Holder with Lead Cable
- Tweco® 200 Amp Earth Clamp with Lead Cable
- 120/230 V Power Adapter
- Victor® Flow Meter with 10 ft (3 m) Gas Hose
- Remote Amperage Foot Control
- ESAB sample spool .030" (0.8 mm) 70S-6 wire
- ESAB Atom Arc Acclaim 1/8" Premium Stick Electrodes 1# Sample Pack
- Drive Rolls for .023" (0.6 mm), .030" (0.8 mm) and .035" (0.9 mm) Wire Diameter
- Guide Tubes .023" -.045" (0.6 mm -1.2 mm)
- Thickness Gauge
- Welding chart (French) Milar
- USB Stick Including Manuals
- Quick Start Guide
- Safety manual

2.2 Overheating protection

**CAUTION!**

This unit is equipped with overheating protection for its power supply.

The welding power source has overheating protection that operates if the internal temperature becomes too high. When this occurs, the welding current is interrupted, and an overheating symbol appears on the display. The overheating protection resets automatically when the temperature has returned to normal working temperature.

3 TECHNICAL DATA

3.1 EMP 205ic AC/DC specifications

	EMP 205ic AC/DC	
Voltage	230 V, 1 ph, 50/60 Hz	120 V, 1 ph, 50/60 Hz
Primary current		
I_{max} . GMAW – MIG	29.6 A	Breaker 20 A: 27.1 A Breaker 15 A: 20.2 A
I_{max} . GTAW – DC TIG	24.0 A	Breaker 15 A: 20.7 A
I_{max} . GTAW – AC TIG	26.5 A	Breaker 15 A: 21.4 A
I_{max} . SMAW – Stick	28.3 A	Breaker 15 A: 20.5 A
I_{eff} . GMAW – MIG	14.8 A	Breaker 20 A: 15.8 A Breaker 15 A: 14.5 A
I_{eff} . GTAW – DC TIG	12.0 A	Breaker 15 A: 14.3 A
I_{eff} . GTAW – AC TIG	13.3 A	Breaker 15 A: 14.9 A
I_{eff} . SMAW – Stick	14.1 A	Breaker 15 A: 14.4 A
Permissible load at GMAW – MIG		
100% duty cycle*	110 A ($V_{out} = 19.5$ V)	Breaker 15 A: 65 A ($V_{out} = 17.25$ V) Breaker 20 A: 70 A ($V_{out} = 17.5$ V)
60% duty cycle*	125 A ($V_{out} = 20.25$ V)	Breaker 15 A: 85 A ($V_{out} = 18.25$ V) Breaker 20 A: 90 A ($V_{out} = 18.5$ V)
40% duty cycle*	150 A ($V_{out} = 21.5$ V)	Breaker 15 A: 90 A ($V_{out} = 18.5$ V)
25% duty cycle*	205 A ($V_{out} = 24.25$ V)	—
20% duty cycle*	—	Breaker 20 A: 115 A ($V_{out} = 19.75$ V)
Setting range (DC)	15 A ($V_{out} = 14.75$ V) – 235 A ($V_{out} = 26.0$ V)	15 A ($V_{out} = 14.75$ V) – 130 A ($V_{out} = 20.5$ V)
Permissible load at GTAW – DC TIG		
100% duty cycle*	110 A ($V_{out} = 14.4$ V)	Breaker 15 A: 80 A ($V_{out} = 13.2$ V)

EMP 205ic AC/DC		
60% duty cycle*	125 A ($V_{out} = 15.0$ V)	Breaker 15 A: 100 A ($V_{out} = 14.0$ V)
40% duty cycle*	—	Breaker 15 A: 110 A ($V_{out} = 14.4$ V)
25% duty cycle*	205 A ($V_{out} = 18.2$ V)	—
Setting range (DC)	5 A ($V_{out} = 10.2$ V) – 205 A ($V_{out} = 18.2$ V)	5 A / 10.2 V – 130 A ($V_{out} = 15.2$ V)
Permissible load at GTAW – AC TIG		
100% duty cycle*	110 A ($V_{out} = 14.4$ V)	Breaker 15 A: 75 A ($V_{out} = 13.0$ V)
60% duty cycle*	125 A ($V_{out} = 15.0$ V)	Breaker 15 A: 95 A ($V_{out} = 13.8$ V)
40% duty cycle*	—	Breaker 15 A: 105 A ($V_{out} = 14.2$ V)
25% duty cycle*	205 A ($V_{out} = 18.2$ V)	—
Setting range (DC)	10 A ($V_{out} = 10.4$ V) – 205 A ($V_{out} = 18.2$ V)	10 A / 10.4 V – 130 A ($V_{out} = 15.2$ V)
Permissible load at SMAW – STICK		
100% duty cycle*	100 A ($V_{out} = 24$ V)	55 A ($V_{out} = 22.2$ V)
60% duty cycle*	125 A ($V_{out} = 25$ V)	70 A ($V_{out} = 22.8$ V)
40% duty cycle*	—	75 A ($V_{out} = 23.0$ V)
25% duty cycle*	170 A ($V_{out} = 26.8$ V)	—
Setting range (DC)	16 A ($V_{out} = 20.6$ V) – 180 A ($V_{out} = 27.2$ V)	16 A ($V_{out} = 20.6$ V) – 130 A ($V_{out} = 25.2$ V)
Open circuit voltage (OCV)		
VRD deactivated	68 V	
VRD activated	35 V	
Efficiency	78%	
Power factor	0.98	
Wire feed speed	80–475 in./min (2–12.1 m/min)	
Wire diameter		
Mild steel solid wire	0.023–0.035 in. (0.6–0.9 mm)	
Stainless steel solid wire	0.030–0.035 in. (0.8–0.9 mm)	
Flux-cored wire	0.030–0.045 in. (0.8–1.1 mm)	
Aluminum	0.030–3/64 in. (0.8–1.2 mm)	
Bobbin size	4–8 in. (100–200 mm)	

	EMP 205ic AC/DC
Dimensions l × w × h	23 × 9 × 16 in. (548 × 229 × 406 mm)
Weight	50 lb. (22.7 kg)
Operating temperature	14 to 104 °F (-10 to +40 °C)
Enclosure class**	IP23S
Application class***	S

Duty cycle

The duty cycle refers to the time as a percentage of a ten-minute period that you can weld or cut at a certain load without overloading. The duty cycle is valid for 104 °F (40 °C).

Enclosure class

The **IP** code indicates the enclosure class, i.e. the degree of protection against penetration by solid objects or water.

Equipment marked **IP 23S** is intended for indoor and outdoor use; however, should not be operated in precipitation.

Application class

The symbol **S** indicates that the power source is designed for use in areas with increased electrical hazard.

4 INSTALLATION

The installation must be carried out by a professional.



CAUTION!

This product is intended for industrial use. In a domestic environment, this product may cause radio interference. It is the user's responsibility to take adequate precautions.

4.1 Location

Position the power source so that its cooling air inlets and outlets are not obstructed.

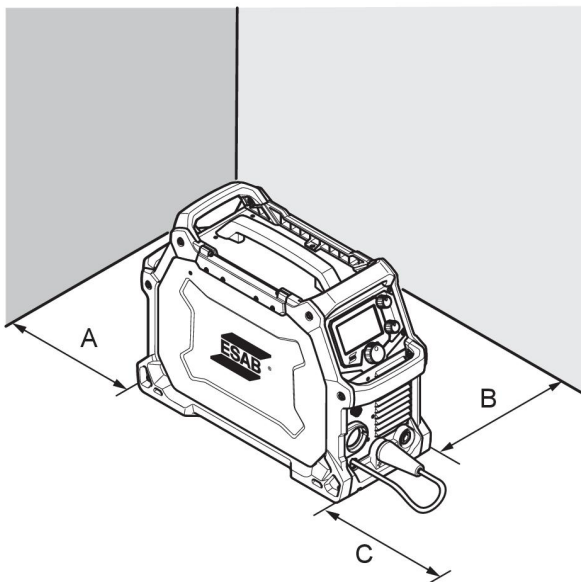

A. 6 in. (152 mm)

B. 4 in. (100 mm)

C. 6 in. (152 mm)

If permanent installation leave enough room to open door and access bobbin side.

4.2 High frequency interference



WARNING!

The high frequency section of this machine has an output like a radio transmitter. The power source should NOT be used near blasting operations due to the danger of premature firing.



WARNING!

Operation close to computer installations may cause computer malfunction.



WARNING!

HIGH FREQUENCY FIELDS CAN BE DANGEROUS TO HEALTH. Extra precautions may be required when this welding power source is used in a domestic situation. Welders with medical pacemakers should consult their doctor before welding. EMF may interfere with some pacemakers.

**WARNING!**

The welding circuit may or may not be earthed for safety reasons. Changing the earthing arrangements should only be authorized by a person who is competent to assess whether the changes will increase the risk of injury, for example: by allowing parallel welding current return paths which may damage the earth circuits of other equipment.

**WARNING!**

Equipotential bonding:

Bonding of all metallic components in the welding installation and adjacent to it might be considered. However, metallic components bonded to the work piece will increase the risk that the operator could receive a shock by touching the metallic components and the electrode at the same time. The operator should be insulated from all such bonded metallic components.

**WARNING!**

Earthing/grounding of the work place:

Care should be taken to prevent the earthing of the work piece increasing the risk of injury to users, or damage to other electrical equipment. Changing the earthing arrangements should only be authorized by a person who is competent to assess whether the changes will increase the risk of injury.

**WARNING!**

The importance of correct installation of high frequency welding equipment cannot be overemphasized. Interference due to high frequency initiated or stabilized arc is almost invariably traced to improper installation. A duly authorized person such as a properly licensed electrician should perform the installation to avoid injury, death, or any equipment damage.

4.2.1 User's responsibility

The user is responsible for installing and using the welding equipment according to the manufacturer's instructions. If electromagnetic disturbances are detected, then it shall be the responsibility of the user of the welding equipment to resolve the situation with the technical assistance of the manufacturer. This remedial action may be as simple as earthing the welding circuit. In other cases, it could involve constructing an electromagnetic screen enclosing the welding power source and the work, complete with associated input filters. In all cases, electromagnetic disturbances shall be reduced to the point where they are no longer troublesome.

4.2.2 Assessment of area

Before installing welding equipment, the user shall assess potential electromagnetic problems in the surrounding area. The following shall be considered:

1. Other supply cables, control cables, signaling and telephone cables; above, below and adjacent to the welding equipment.
2. Radio and television transmitters and receivers.
3. Computer and other control equipment.
4. Safety critical equipment, e.g. guarding of industrial equipment.
5. The health of people around, e.g. the use of pacemakers and hearing aids.
6. Equipment used for calibration and measurement.
7. The time of day that welding or other activities are to be carried out.

8. The immunity of other equipment in the environment: the user shall ensure that other equipment being used in the environment is compatible: this may require additional protection measures.
9. The size of the surrounding area to be considered will depend on the structure of the building and other activities that are taking place. The surrounding area may extend beyond the boundaries of the premises.

Interference may be transmitted by a high frequency initiated or stabilized arc welding power source in the following ways:

- Direct radiation: Radiation from the equipment can occur if the case is metal and is not properly grounded. It can occur through apertures such as open access panels. The shielding of the high frequency unit in the power source will prevent direct radiation if the equipment is properly grounded.
- Transmission via the supply lead: Without adequate shielding and filtering, high frequency energy may be fed to the wiring within the installation (mains) by direct coupling. The energy is then transmitted by both radiation and conduction. Adequate shielding and filtering is provided in the power source.
- Radiation from welding leads: Radiated interference from welding leads, although pronounced near the leads, diminishes rapidly with distance. Keeping leads as short as possible will minimize this type of interference. Looping and suspending of leads should be avoided wherever possible.
- Re-radiation from unearthed metallic objects: A major factor contributing to interference is re-radiation from unearthed metallic objects close to the welding leads. Effective grounding of such objects will prevent re-radiation in most cases.

4.3 Lifting instructions

The power source can be lifted using any of the handles.

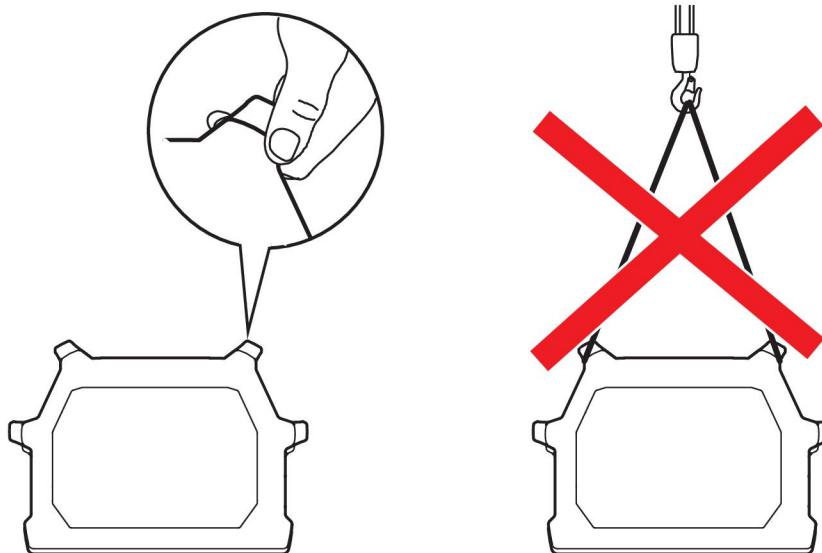

**WARNING!**

Secure the equipment - particularly if the ground is uneven or sloping.

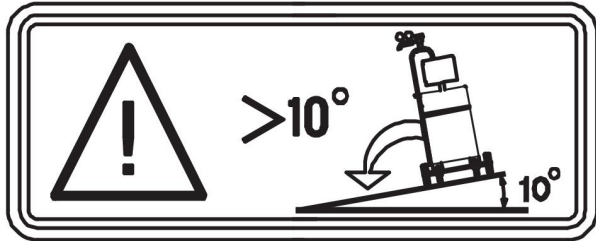

4.4 Mains supply

**NOTE!****Mains supply requirements**

This equipment complies with IEC 61000-3-12 provided that the short-circuit power is greater than or equal to S_{scmin} at the interface point between the user's supply and the public system. It is the responsibility of the installer or user of the equipment to ensure, by consultation with the distribution network operator if necessary, that the equipment is connected only to a supply with a short-circuit power greater than or equal to S_{scmin} . Refer to the technical data in the TECHNICAL DATA chapter.

The supply voltage should be 230 V AC $\pm 10\%$ or 120 V AC $\pm 10\%$. Too low supply voltage may cause poor welding performance. Too high supply voltage will cause components to overheat and possibly fail. Contact the local electric utility for information about the type of electrical service available, how proper connections should be made, and inspection required.

The welding power source must be:

- Correctly installed, if necessary, by a qualified electrician.
- Correctly earthed (electrically) in accordance with local regulations.
- Connected to the correct size power point and fuse as tables below.

**NOTE!**

Use the welding power source in accordance with the relevant national regulations.

**CAUTION!**

Disconnect input power and secure employing "Lock-out/Tagging" procedures. Ensure input power line disconnect switch is locked (Lock-out/Tagging) in the "Open" position BEFORE removing input power fuses. Connecting/disconnecting should be carried out by competent persons.

1. Rating plate with supply connection data

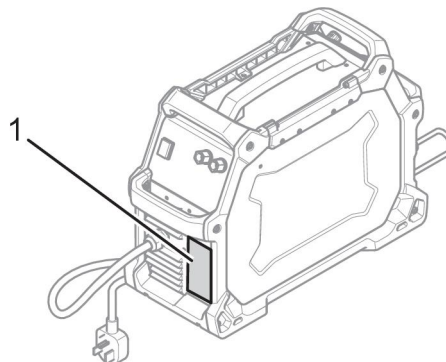

4.5 Recommended electrical-supply specifications



WARNING!

An electrical shock or fire hazard is probable if the following electrical service guide recommendations are not followed. These recommendations are for a dedicated branch circuit sized for the rated output and duty cycle of the welding power source.

Recommended electrical supply specifications: 120–230 V, 1 – 50/60 Hz		
Specification	230 V AC	120 V AC
Input current at maximum output	33 A	30 A
Maximum recommended fuse* or circuit breaker rating	40 A	30 A
*Time delay fuse UL class RK5, refer to UL 248		
Maximum recommended fuse* or circuit breaker rating Normal operating UL class K5, refer to UL 248	50 A	50 A
Minimum recommended cord size	13 AWG (2.5 mm ²)	13 AWG (2.5 mm ²)
Maximum recommended extension cord length	50 ft (15 m)	25 ft (8 m)
Minimum recommended grounding conductor size	13 AWG (2.5 mm ²)	13 AWG (2.5 mm ²)

4.6 Supply from power generators

The power source can be supplied from different types of generators. However, some generators may not provide sufficient power for the welding power source to operate correctly.

Generators with Automatic Voltage Regulation (AVR) or with equivalent or better type of regulation, with rated power of minimum 8 kW 1 phase, are recommended.

5 OPERATION

General safety regulations for handling the equipment can be found in the chapter "Safety". Read it through before you start the equipment.



NOTE!

When moving the equipment use intended handle. Never pull the cables.



WARNING!

Rotating parts can cause injury, take great care.



WARNING!

Electric shock! Do not touch the workpiece or the welding head during operation!



WARNING!

Assure that the side covers are closed during operation.



WARNING!

Tighten the bobbin bolt to prevent it from sliding off the hub.

5.1 Connections and controls

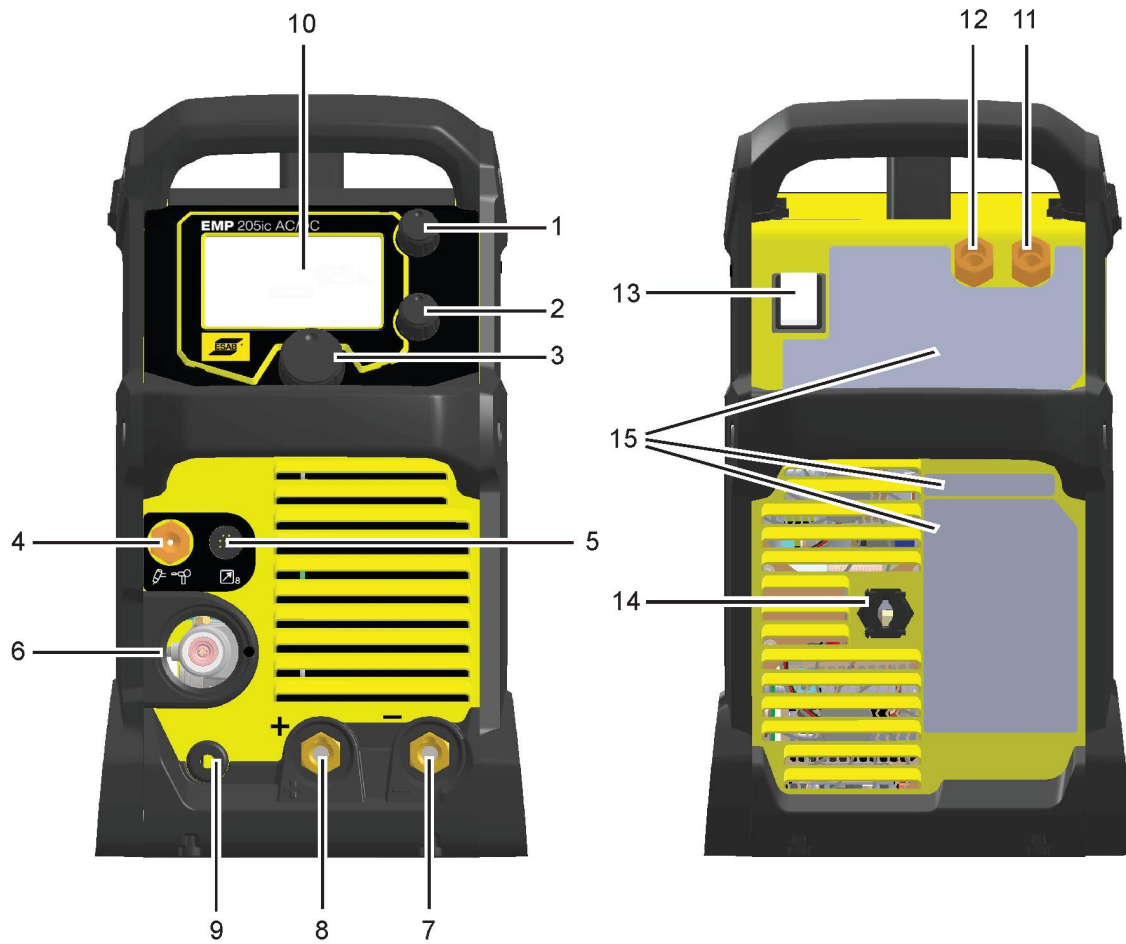

Figure 1. Front & rear views: Model EMP 205ic AC/DC

- | | |
|--|------------------------------|
| 1. Knob for current or wire feed speed selection | 9. Polarity changeover cable |
| 2. Knob for voltage selection | 10. Display |
| 3. Main knob for menu navigation | 11. Gas inlet for MIG/MAG |
| 4. Gas outlet | 12. Gas inlet for TIG |
| 5. Torch/remote control connection | 13. Main power switch ON/OFF |
| 6. Torch connection | 14. Main power cable |
| 7. Negative output [-] | 15. Labels |
| 8. Positive output [+] | |

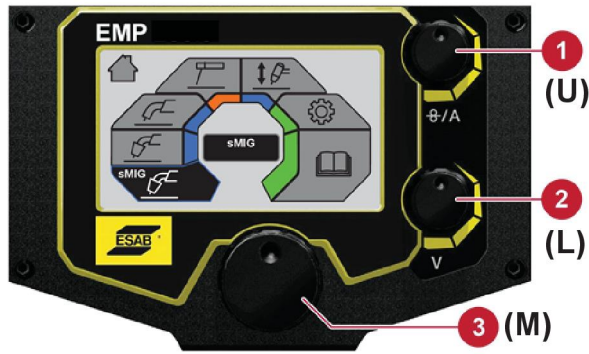

Figure 2. Function of user interface control dials

1. **(U) Upper control knob:** (a) Set current output value (b) Set wire feed speed
2. **(L) Lower control knob:** (a) MIG voltage selection (b) SMIG voltage trim (c) MMA mode: Arc ON/OFF
3. **(M) Menu navigation:** Push to select



NOTE!

Lower control knob (2) in MMA Mode turns output power ON/OFF. When output power is ON, background of display turns orange (see "CONTROL PANEL" chapter).

5.2 Connection of welding and return cables

The power source has two outputs for connecting welding and return cables: a negative [-] terminal (7) and a positive [+] terminal (8) (see Figure 1).

5.2.1 For MIG/MMA process

For MIG/MMA process, the output to which the welding cable is connected depends on the type of electrode. Refer to electrode packaging for information relating to the correct electrode polarity. Connect the return cable to the remaining welding terminal (9) on the power source.

Secure the return cable's contact clamp to the work piece and ensure that there is good electrical contact. Connect the torch connector to the Torch connection (6).



NOTE!

MIG welding guidance chart:

The backside of the door on the bobbin side displays a MIG welding guidance chart for initial selection of welding controls. This is intended as a guide for setting parameters on this equipment.

5.2.2 For TIG process

For TIG process (requires optional TIG accessories), connect the TIG torch power cable to the negative [-] terminal (7), see illustration. Connect the gas inlet nut on the TIG torch to the gas outlet connector (4) located on the front of the power source. Connect the gas inlet nut (12), on rear panel, to a regulated shielding gas supply. Connect the work return lead to the return-cable terminal (9). Connect the torch connector to the torch connection (6) (see Figure 1).

5.3 Polarity change



Figure 3. Polarity changeover connections

1. Polarity changeover cable

Check the recommended polarity for the welding wire you want to use. Refer to electrode packaging for information relating to the correct electrode polarity. The polarity can be changed by moving the polarity changeover cable to suit the applicable welding process.

5.4 Shielding gas

The choice of suitable shielding gas depends on the material. Typically, mild steel is welded with mixed gas (Ar + CO₂) or 100% carbon dioxide (CO₂). Stainless steel can be welded with mixed gas (Ar + CO₂) or trimix (He + Ar + CO₂). Aluminum and silicon bronze use pure argon gas (Ar). In the sMIG mode (see "sMIG mode" section in the "CONTROL PANEL" chapter), the optimal welding arc with the gas used will be automatically set.

5.5 Volt-ampere curves

The curves below show the maximum voltage and amperage output capabilities of the power source for three common welding process settings. Other settings result in curves that fall between these curves.

A= Welding current (AMPS), **V** = Output voltage

5.5.1 SMAW (Stick) 120 V

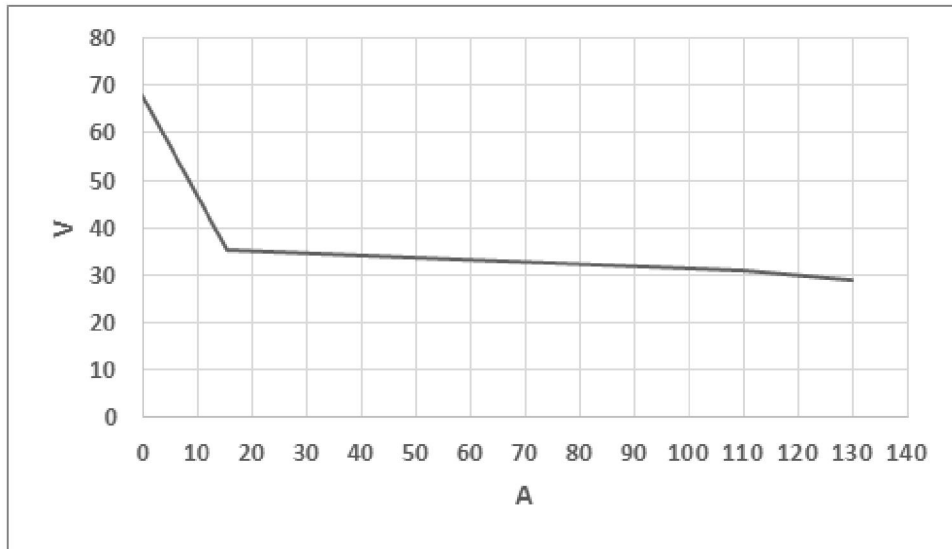

5.5.2 SMAW (Stick) 230 V

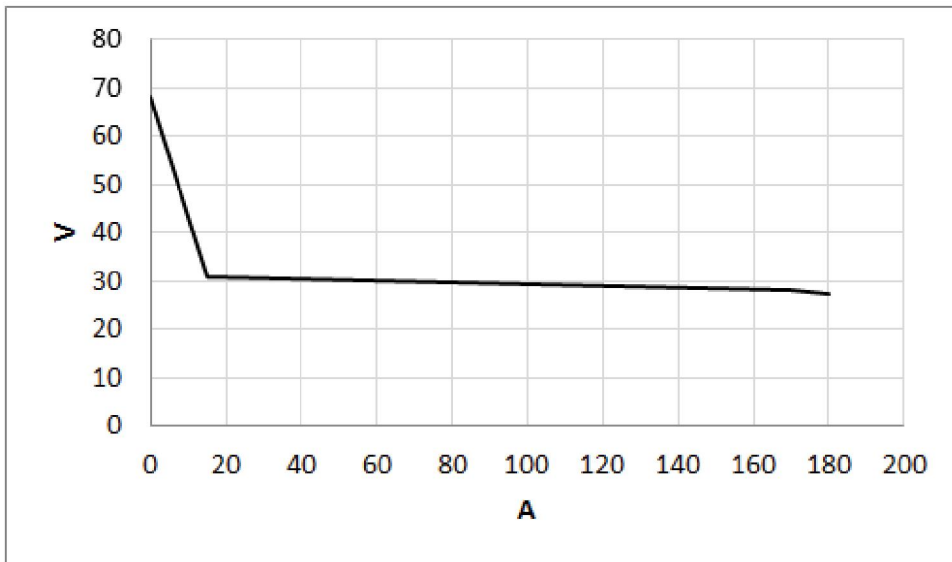

5.5.3 GMAW (MIG) 120 V

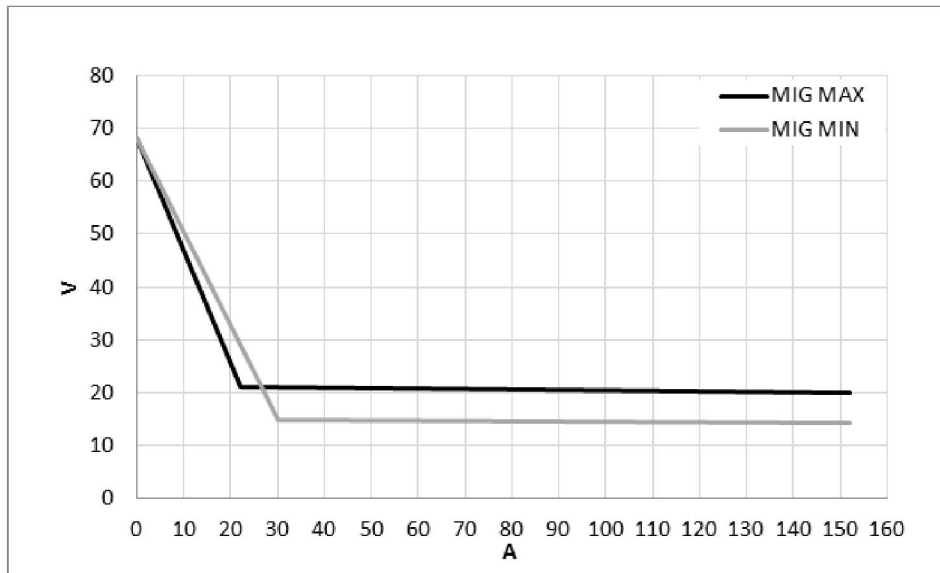

5.5.4 GMAW (MIG) 230 V

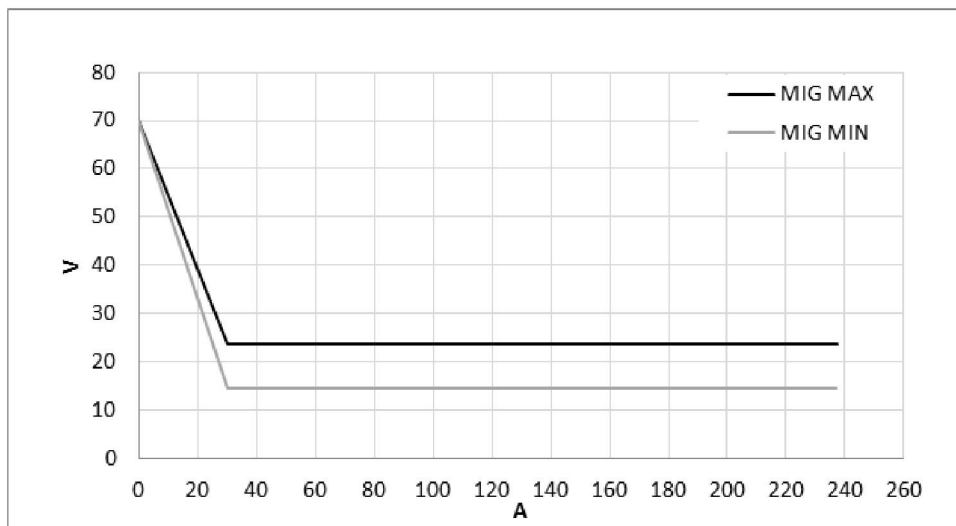

5.5.5 GTAW (DC TIG) 120 V

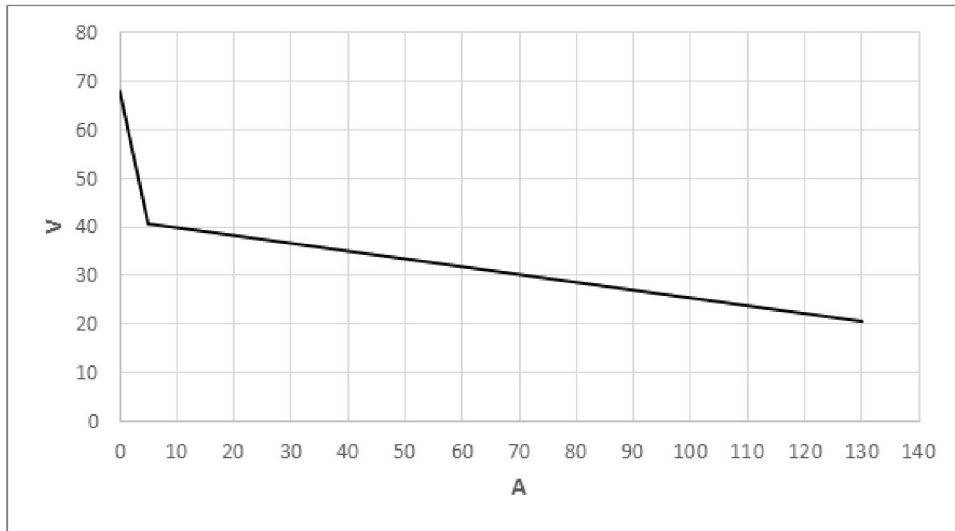

5.5.6 GTAW (DC TIG) 230 V

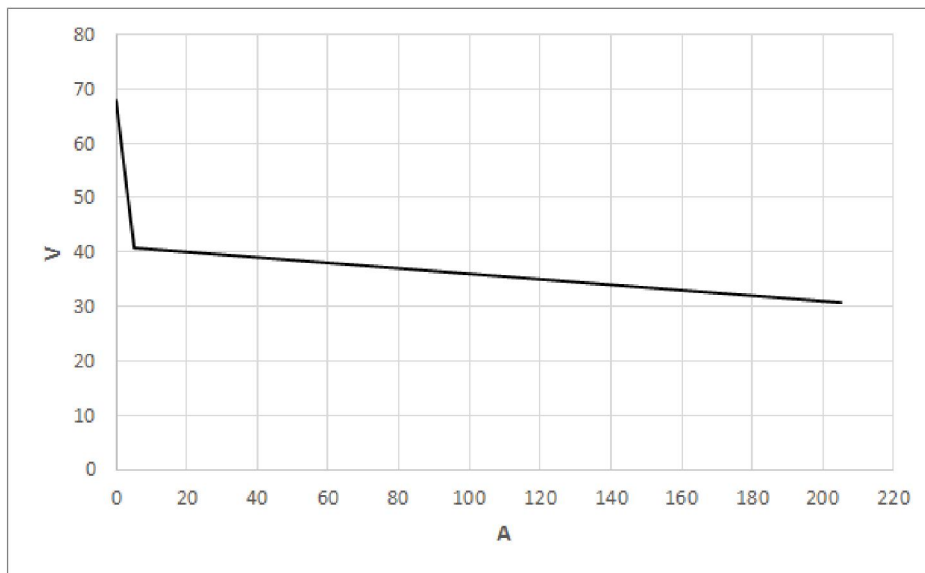

5.5.7 GTAW (AC TIG) 120 V

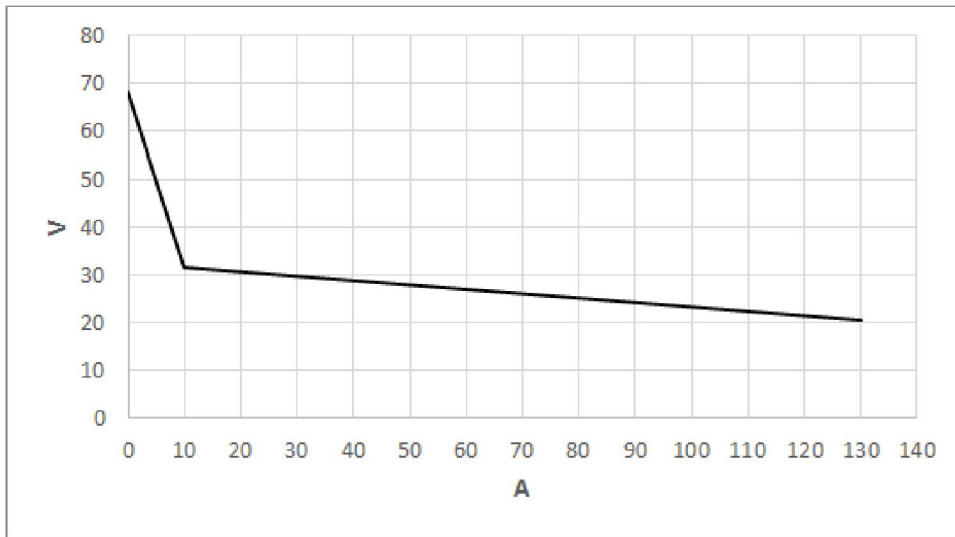

5.5.8 GTAW (AC TIG) 230 V

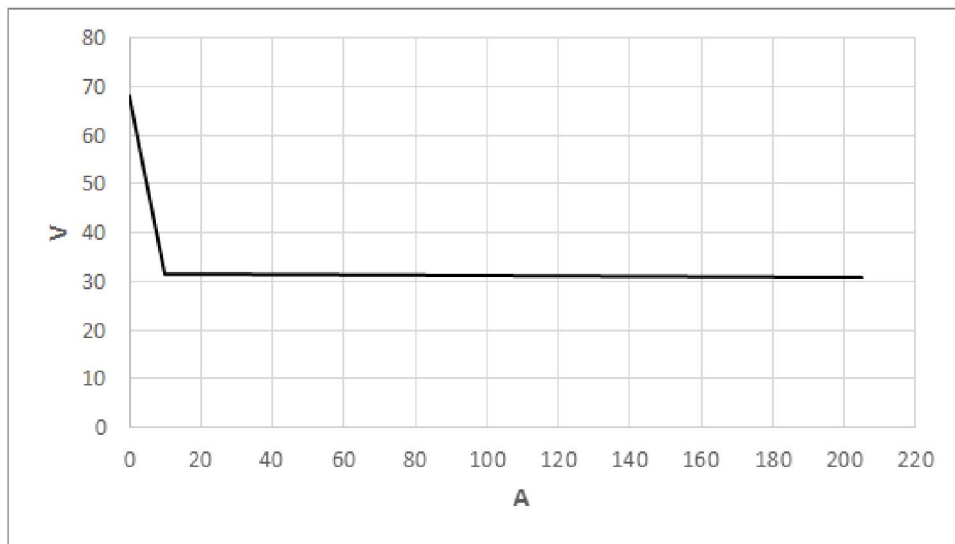

5.5.9 Duty cycle

5.5.9.1 25% duty cycle

The EMP 205ic AC/DC has a welding current output of 205 A at 25% duty cycle (230 V). A self-resetting thermostat will protect the power source if the duty cycle is exceeded.

Example: If the power source operates at a 25% duty cycle, it will provide the rated amperage for a maximum of 2.5 minutes out of every 10-minute period. The remaining time, 7.5 minutes, the power source must be allowed to cool down.

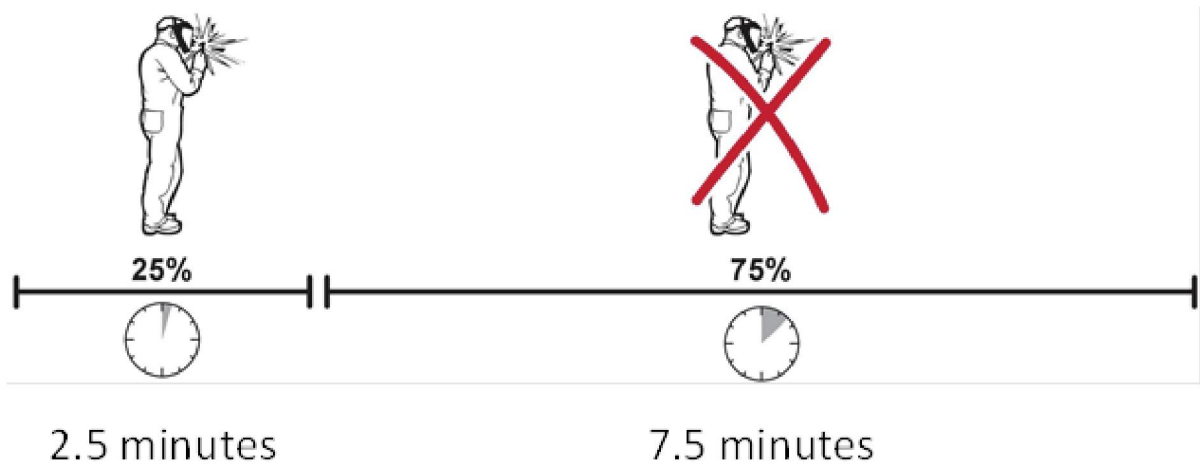

Figure 4. Example of 25% duty cycle

A different combination of duty cycle and welding current can be selected. Use the graphs below to determine the correct duty cycle for a given welding current.

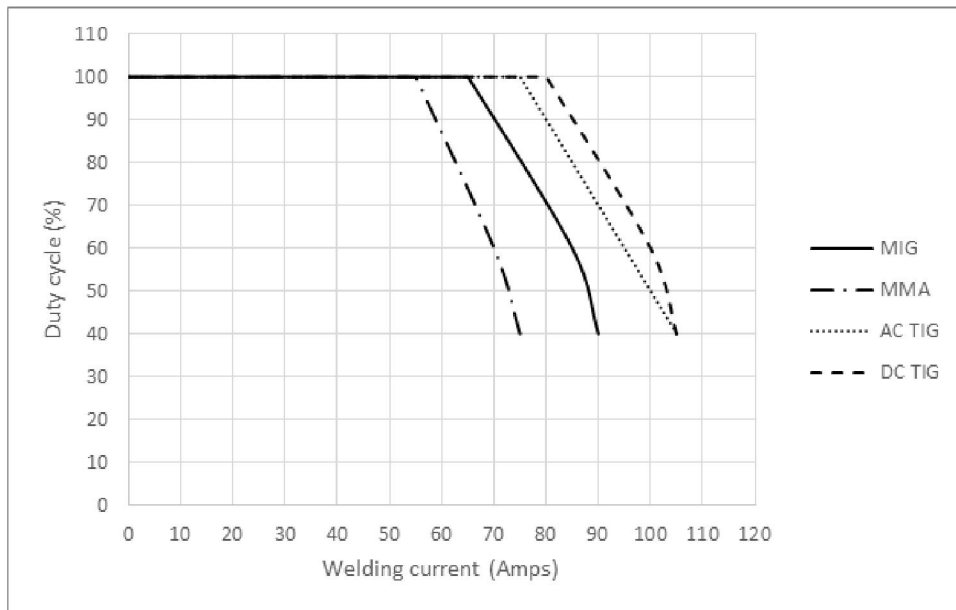

Figure 5. Plotting duty cycle for 120 V

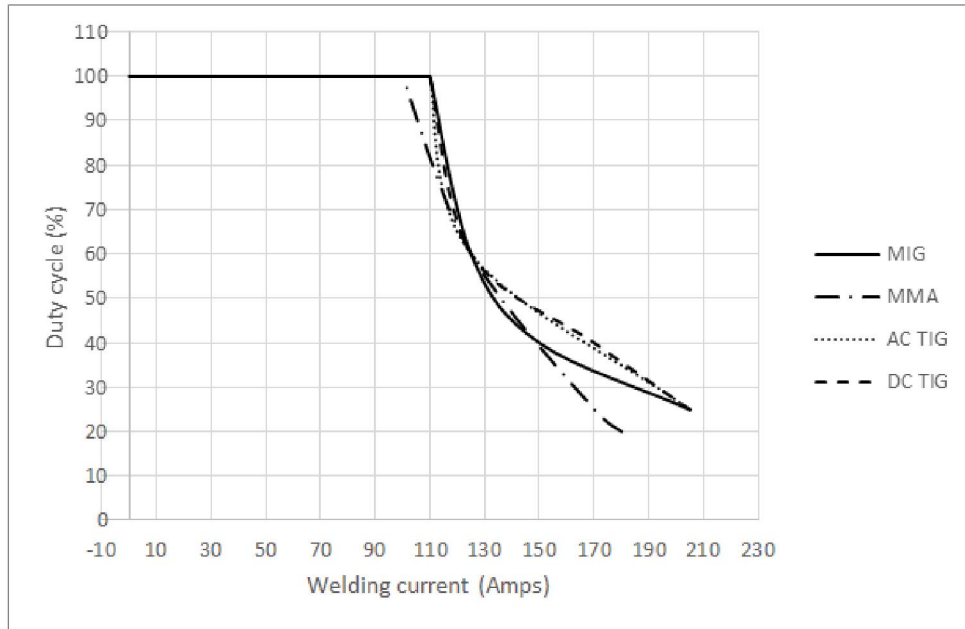

Figure 6. Plotting duty cycle for 230 V

5.6 Removing/installing bobbin



NOTE!

The gas does not need to be connected for this procedure. **Power should be turned off for this procedure.**

The spring sets the "braking value" working against the wire-feed motor and the pull of the roller-feed wheels. Tighten the bolt "A", see illustrations below, hand tight.

Remove/Install the bobbin as shown in below.

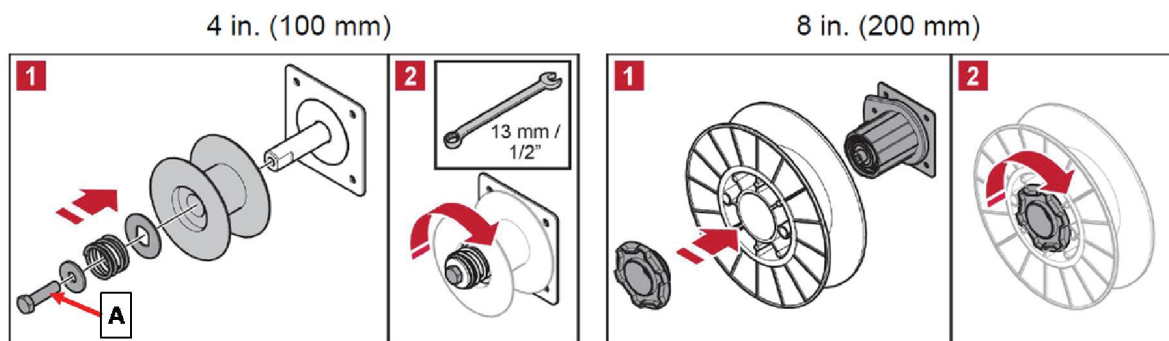

Figure 7. Tightening the bobbin locking nut for 4 in. (100 mm)

A. Bobbin locking nut

5.7 Removing/installing wire



NOTE!

If installing aluminum wire, see "Welding with aluminum wire" section.

The EMP 205ic AC/DC will handle the two smaller bobbin sizes of 4 in. (100 mm), and 8 in. (200 mm). See "TECHNICAL DATA" chapter for suitable wire dimensions for each wire type.

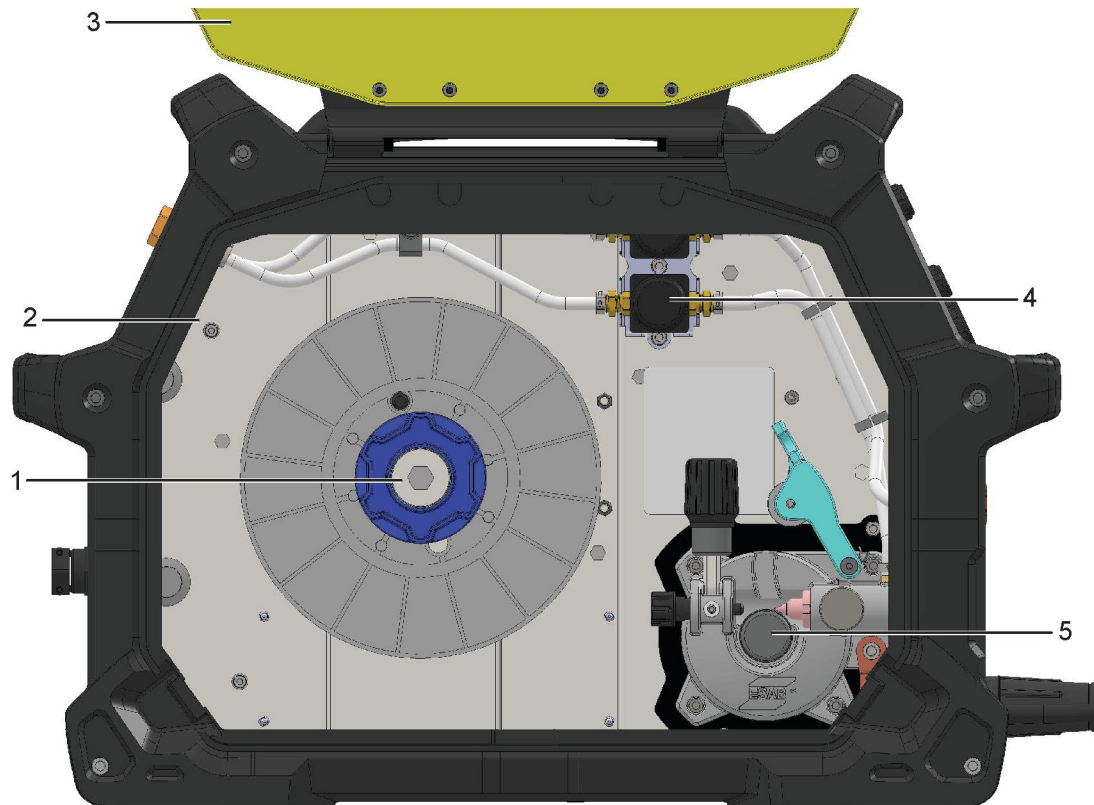

Figure 8. View of wire-bobbin side

- | | |
|----------------------|-----------------------|
| 1. Wire-bobbin shaft | 4. Gas valves |
| 2. Circuit breaker | 5. Wire-feed assembly |
| 3. Door (shown open) | |



WARNING!

Do not place or point the torch near the face, hand or body as this may result in injury.



NOTE!

Make sure the correct wire-feed rollers are selected.



NOTE!

Use the correct contact tip in the welding torch for the wire diameter used.

5.7.1 Removing wire

1. Disconnect the electrical power source from the unit.
2. Open the wire-bobbin side cover of the EMP unit and observe how the wire feeds from the bobbin, through the wire feed assembly and into the torch connection.

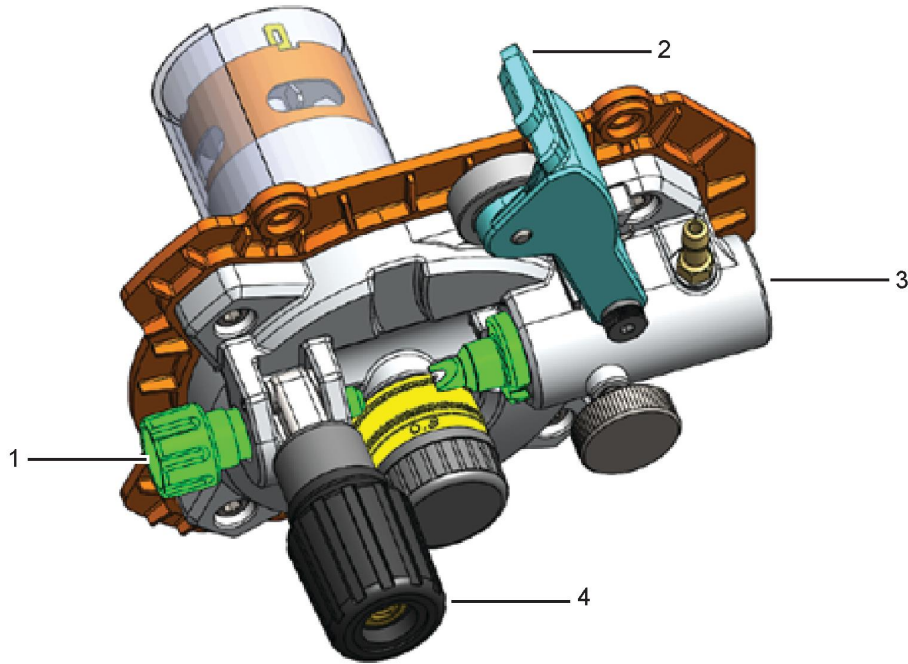

Figure 9. Path of wire through wire feed assembly

- | | |
|--------------------------------|--|
| 1. Wire from bobbin | 3. Wire to torch |
| 2. Pressure arm (shown raised) | 4. Tension knob assembly (shown lowered) |

3. Locate the wire-feed assembly and its tension-knob.

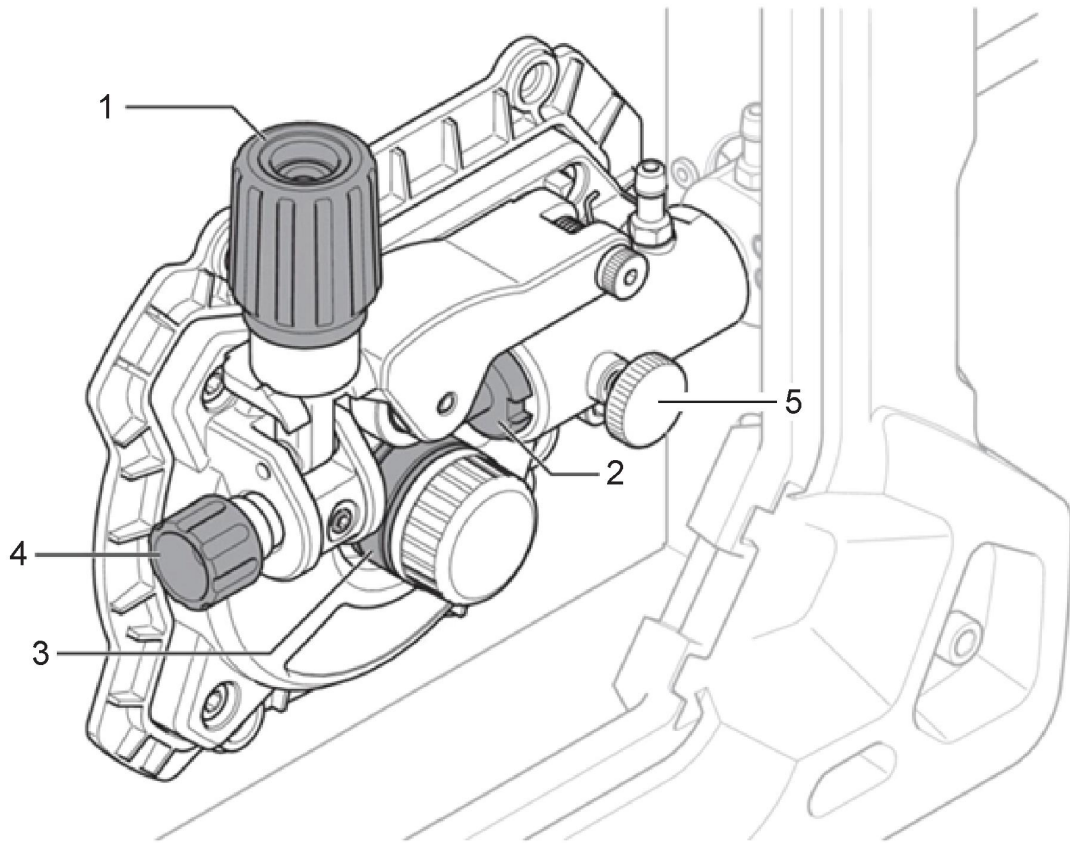

Figure 10. Wire-feed assembly part names

- | | |
|----------------------|---------------------------|
| 1. Tension knob | 4. Inlet wire-guide |
| 2. Outlet wire-guide | 5. MIG torch locking knob |
| 3. Wire-feed roller | |

- On the wire-feed assembly release the tensioning arm by partially unscrewing the tension knob, pulling it up out of its detent and rotating it toward you.

**NOTE!**

The tensioning arm is spring-loaded. It will pop-up when the tension knob is rotated out-of-the-way.

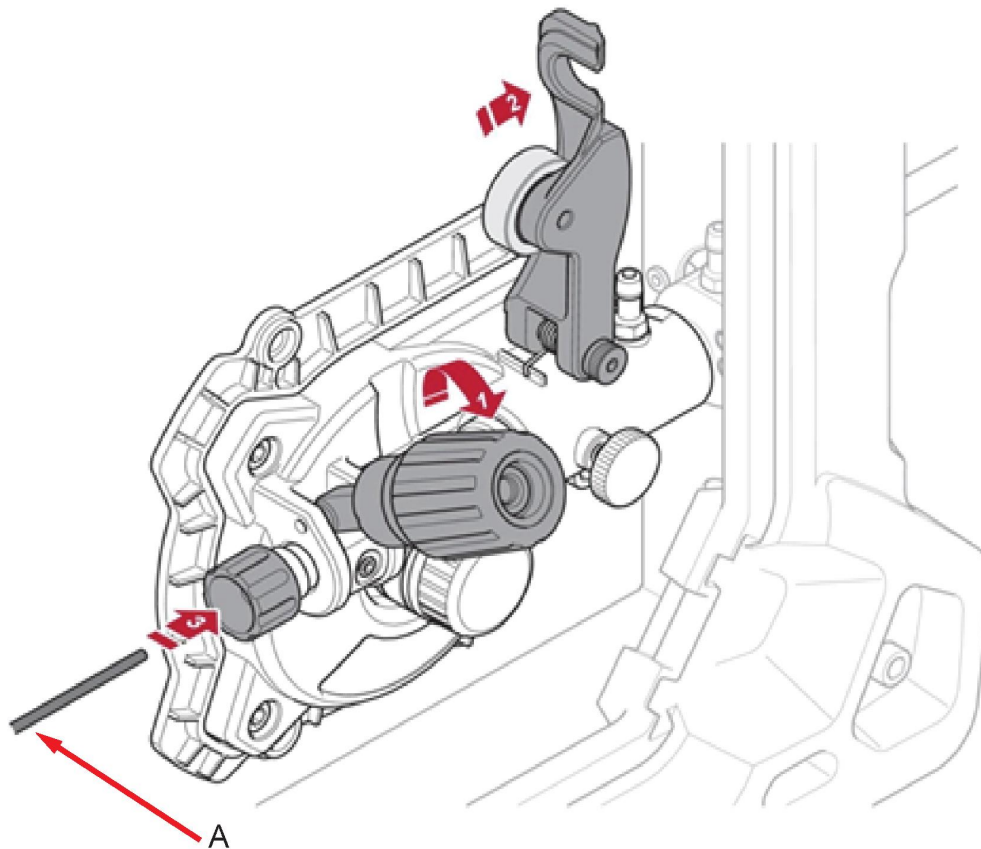

Figure 11. Wire-feed mechanism

A. Wire in from bobbin

- If wire remains in the torch assembly:**
Near the inlet wire-guide on the wire-feed assembly (see Figure 10) cut the wire while holding the bobbin-end (so the wire does not unravel from the bobbin after cutting it loose). Secure the cut end of the wire to the bobbin (if any wire is left on the bobbin) to prevent the wire from unraveling from the bobbin.
- If wire remains in the torch assembly:**
Disconnect the torch assembly from the EMP unit by loosening the MIG torch locking knob (see Figure 10).
- Pull the remaining length of the wire through the wire-feed assembly and, with the torch, set the torch assembly aside (with the loose wire still installed in the torch). The old wire should now be completely removed from the wire-feed assembly.
- Remove the bobbin from the unit (see "Removing/installing bobbin" section).
- Pull the length of old wire out of the torch assembly from either end of the torch assembly.

5.7.2 Installing wire

- Disconnect the electrical power source from the unit.
- Open the wire-bobbin side cover of the EMP unit.
- Install the new bobbin (see "Removing/installing bobbin" section).

4. **If the tensioning arm is not released:**

On the wire-feed assembly release the tension arm by pulling the tension knob up out of its detent and rotating it toward you. The tension arm is spring-loaded. It will pop-up when the tension knob in the previous step is rotated out-of-the-way.

5. Install rollers for selected wire size (see Appendix C).
6. With a clean-cut (no bends) strait bitter-end pull the wire from the newly-installed bobbin and feed it through the wire-feed assembly until it protrudes out of the output end about 1.18 in. (3 cm).
7. Close the tension-arm onto the wire in its groove on the wire-feed rollers.
8. Re-connect the torch assembly to the EMP unit being careful to insert the bitter end of the wire protruding from the output wire-guide into the torch connector.
9. Power up the EMP unit. Gas does not need to be connected for this procedure.
10. With the torch cable laid out reasonably straight, feed the wire through the torch cable until it is visible at its welding tip by depressing the trigger switch on the torch. Refer to the relevant torch manual for length of wire-protrusion at tip end.
11. To more accurately set and verify the wire-feed tension for correct wire-feed pressure, see "Setting wire-feed pressure" section.
12. Close the cover on the wire-bobbin side of the EMP unit.

5.8 Welding with aluminum wire



NOTE!

After completing the instructions in this section return to "Removing/installing wire" section.

To weld aluminum using the standard supplied torch, refer to MIG torch instruction manual for replacing standard steel torch conduit liner with a teflon torch conduit liner.

- Model EMP 205ic AC/DC uses torch model: Tweco® Fusion™ 180 A MIG torch with 10 ft (3 m) cable / Tweco® pigtail with 0.023 in. (0.6 mm), 0.030 in. (0.8 mm), 0.035 in. (0.9 mm) contact tip and Operator manual.

Order the following accessories:

- Torch teflon conduit liner (PTFE liner), 10 ft (3 m): See PARTS section (Wire liner Table) in the ESAB Torch Instruction Manual (see Note above).
- Teflon coated output wire-guide tube (select size to match wire from Table in Appendix C).

5.9 Setting wire-feed pressure



NOTE!

This procedure requires the unit be powered ON. The gas does not need to be connected for this procedure.

1. Turn power to the unit ON.
2. Start by making sure that the wire moves smoothly through the wire guide.



CAUTION!

It is important that the feed-pressure is not too high or too low.

3. Check that the feed-pressure is set correctly, feed out the wire against an insulated object, e.g. a piece of wood.

4. **Adjusting for minimum roller pressure:**

When you hold the welding torch approximately ¼ in. (6 mm) from the piece of wood (see Figure 12), the wire-feed rollers should slip. If they don't, reduce the tension on the wire by adjusting the tension knob on the wire-feed assembly.

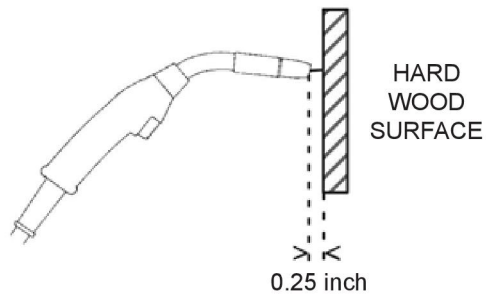

Figure 12. Check feed-roller for slip, indicating no over-pressure

5. **Adjusting for correct roller pressure:**

If you hold the welding torch approximately 2 in. (50 mm) from the piece of wood, the wire should be fed out and bend (Figure 13).

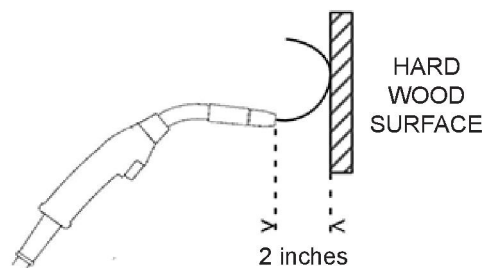

Figure 13. Checking for proper feed-roller pressure

5.10 Removing/installing wire-feed roller



WARNING!

Power should be turned off for this procedure.



NOTE!

Gas does not need to be connected for this procedure.

Different-size pairs of dual-groove feed-rollers are supplied as standard (Listed in Appendix as “DEFAULT” and as “ACCESSORY”). Change the feed rollers to match the wire size/type on the wire bobbin. See Appendix C for feed roller selection. Figure 13 shows location of wire-feed rollers. The pressure rollers are not replaced.

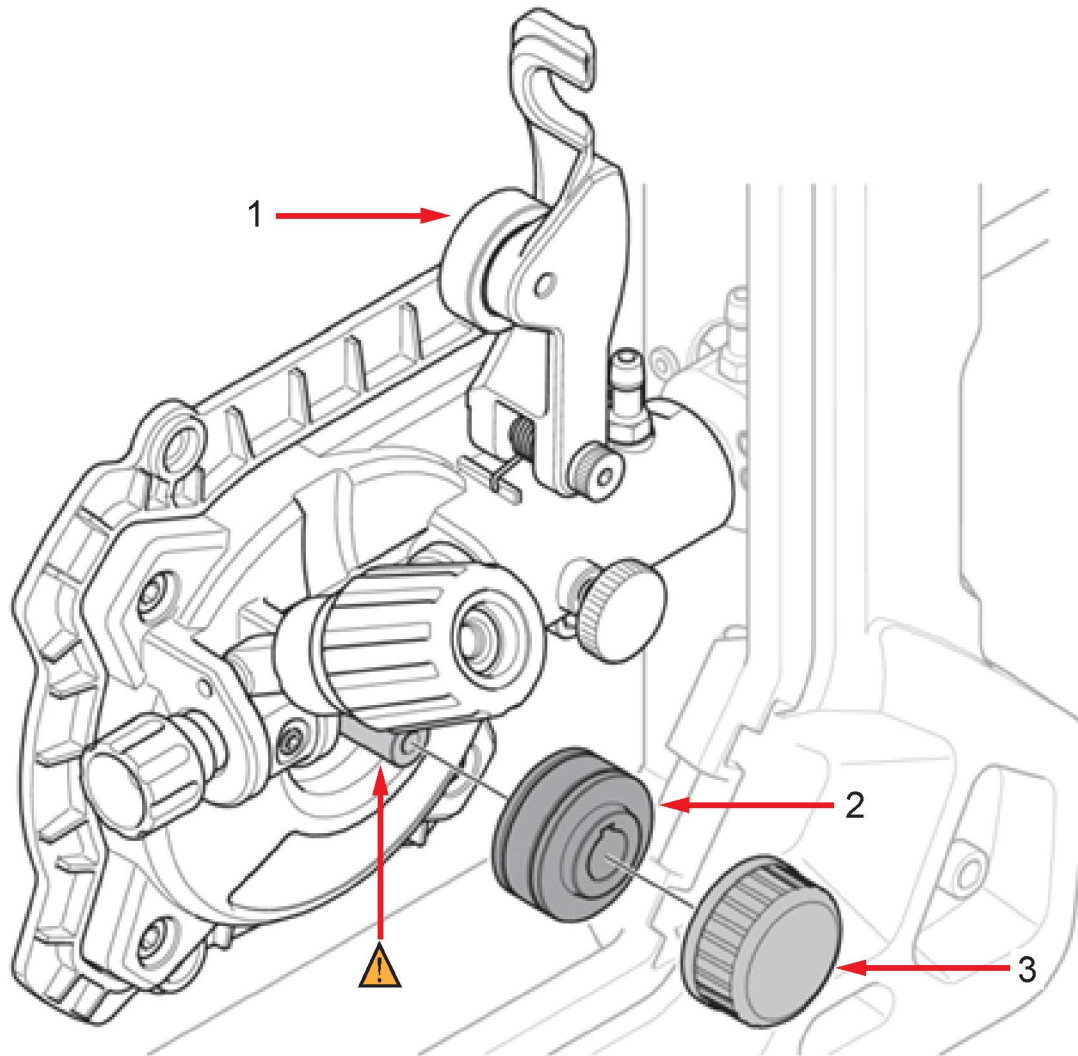

Figure 14. Location of wire-feed rollers and pressure rollers

- | | |
|---|---------------------|
| 1. Caution: Retain drive shaft key on motor shaft | 3. Wire-feed roller |
| 2. Pressure roller | 4. Locking knob |



NOTE!

The visual label stamped on the side of a wire-feed roller and facing you designates the wire-groove size on the opposite (inner) side of the roller. The selected groove should match the wire size being used. Each roller is designed to accommodate two groove-sizes. The groove size on a roller, when facing you matches the groove on the far side of the roller. Install the desired size groove with the label on the roller's side facing you.

5.10.1 Removing wire-feed roller

1. If new rollers are being installed select the correct size and type (steel or aluminum) for wire being installed (see Appendix C).
2. Disconnect the electrical power source from the unit.
3. Open the cover on the wire-bobbin side of the EMP unit.

4. Before moving the tension knob: note its numerical setting as indicated on its body immediately below the handle. Record this number to re-set the tension in its approximate range. Section "Setting wire-feed pressure" describes the fine adjustment for this tension adjustment.



NOTE!

Since the wire-feed pressure adjustment may be disturbed to release this arm, the tension on the rollers will have to be re-adjusted at the end of this procedure. Recording the undisturbed scale number in the previous step facilitates the process at the end of the procedure to accurately set the tension.

5. Release the tensioning arm by loosening the tension knob, pulling it up out of its detent and rotating it toward you, (see 1 in Figure 10). Since the wire-feed pressure must be disturbed to release this arm, the tension on the roller will have to be re-adjusted in a later step.



NOTE!

The tensioning arm is spring-loaded. It will pop-up when the tension knob is rotated out-of-the-way.

6. Lift the wire out of its groove.
7. Remove the wire-feed roller by removing its locking knob and sliding the roller from its shaft.



CAUTION!

When removing the roller be careful **not** to lose the drive-shaft key on the motor shaft. Failure to comply will render the entire unit useless until this part is replaced.

5.10.2 Installing wire-feed roller

1. Install the drive roller (in the correct size and in the correct groove orientation). Verify that the correct size groove is oriented on the **inside** (see Figure 15).



NOTE!

The wire-feed rollers will either be replaced (to correspond with the size and type of the new wire being installed) or reused if the same size and type of wire is being replaced.

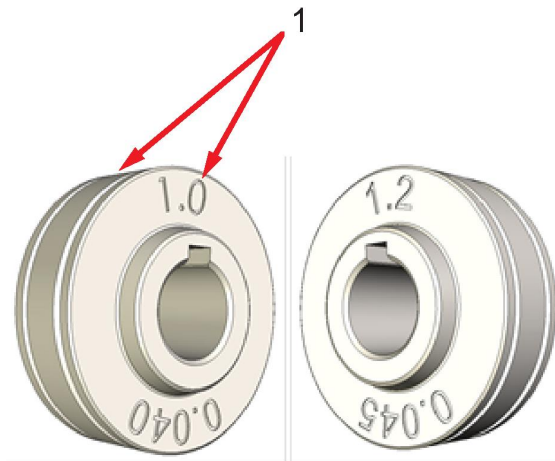

Figure 15. Wire-feed rollers offered in multiple sizes

1. Labels



NOTE!

Label on roller-side matches with the groove on the opposite-side of the roller.

2. Tighten the drive-roller locking knob by turning it in the clockwise direction. Hand-tight is sufficient.
3. Lay the wire into the inside groove of the Wire-Feed roller.



NOTE!

If the wire was removed (not just lifted from the groove in the roller) then the wire will have to be re-installed (see "Installing wire" subsection).

4. Close the pressure rollers on the wire.
5. Adjust the wire-feed pressure by adjusting the tension on the wire at the wire-feed rollers by turning the tension knob using the procedure in "Setting wire-feed pressure" section.
6. Close the cover on the wire-bobbin side of the EMP unit.

6 CONTROL PANEL

General safety regulations for handling the equipment can be found in the "Safety precautions" section in the "SAFETY" chapter of this manual. General information about operation can be found in the "OPERATION" chapter of this manual. Read both chapters thoroughly before you start using the equipment!



NOTE!

After power-on has completed the main menu appears on the control panel.

6.1 How to navigate

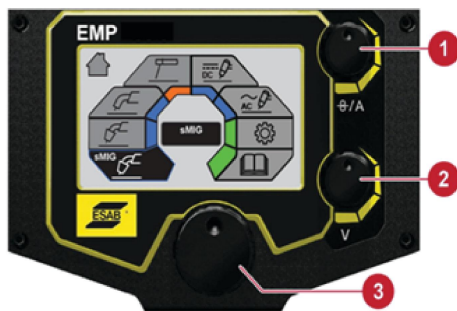

1. Upper control knob
 - a) Set current output value
 - b) Set wire-feed speed
2. Lower control knob
 - a) MIG Voltage Selection
 - b) sMIG Voltage Trim
 - c) MMA Mode: ARC ON/OFF
3. Menu navigation: Push to select

6.2 Main menu

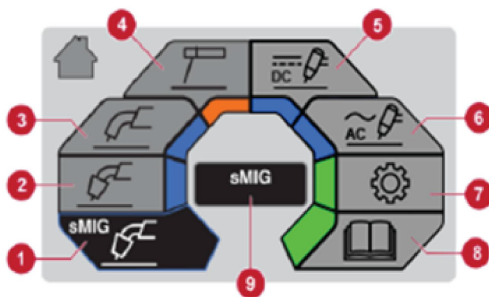

1. sMIG mode
2. Manual MIG mode
3. Flux-cored wire mode
4. MMA mode
5. DC TIG mode
6. AC TIG mode
7. Settings
8. User manual
9. Dialogue box

6.3 sMIG mode: Basic

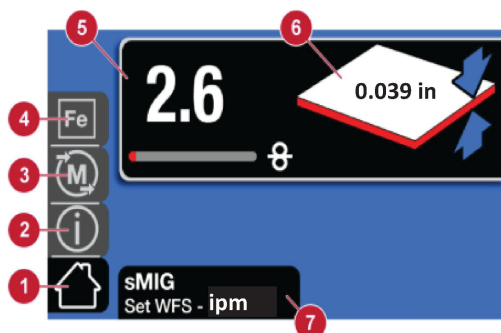

1. Home screen
2. Information
3. Memory
4. Material selection
5. Wire-feed speed selection
6. Material thickness indicator
7. Dialogue box

6.4 sMIG mode: Advanced

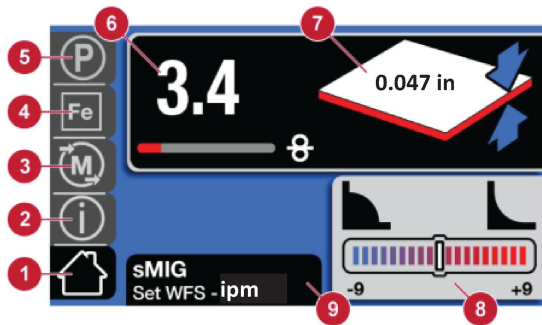

1. Home screen
2. Information
3. Memory
4. Material selection
5. Parameter
6. Wire-feed speed
7. Material thickness indicator
8. Voltage trim adjustment
9. Dialogue box

6.5 Manual MIG mode: Basic

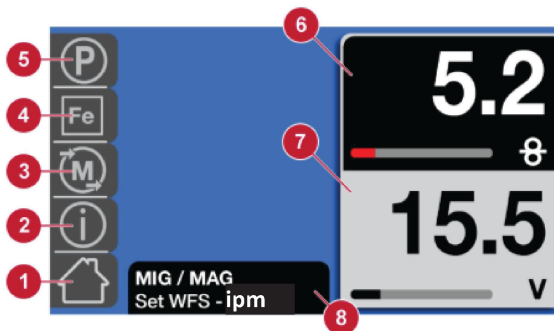

1. Home screen
2. Information
3. Memory
4. Material selection
5. Parameter
6. Wire-feed speed
7. Voltage adjustment
8. Dialogue box

6.6 Manual MIG mode: Advanced

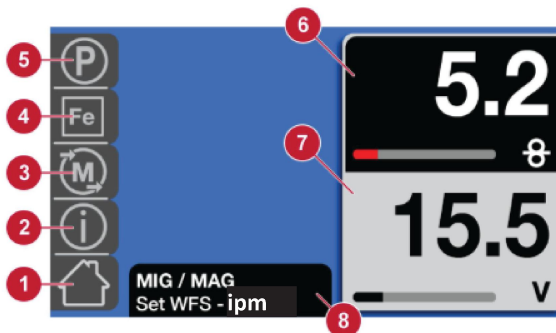

1. Home screen
2. Information
3. Memory
4. Material selection
5. Parameter
6. Wire-feed speed
7. Voltage adjustment
8. Dialogue box

6.7 Flux cored wire mode: Basic

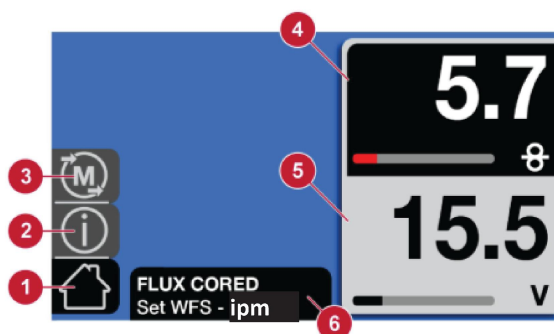

1. Home screen
2. Information
3. Memory
4. Wire-feed speed
5. Voltage adjustment
6. Dialogue box

6.8 Flux cored wire mode: Advanced

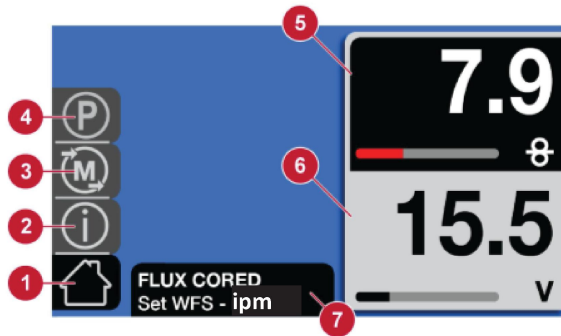

1. Home screen
2. Information
3. Memory
4. Parameter
5. Wire-feed speed
6. Voltage adjustment
7. Dialogue box

6.9 MMA mode: Basic

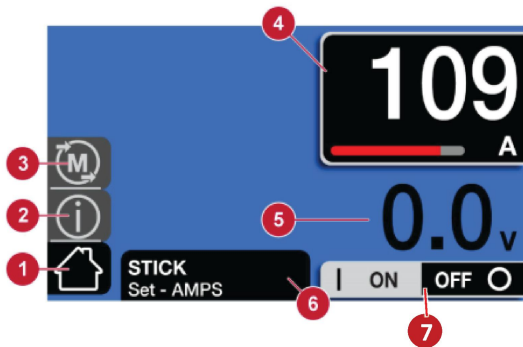

1. Home screen
2. Information
3. Memory
4. Amperage adjustment
5. Power-supply output voltage (Open Circuit Voltage or Arc)
6. Dialogue box
7. Arc ON/OFF

Blue changes to orange when output is "hot".

6.10 MMA mode: Advanced

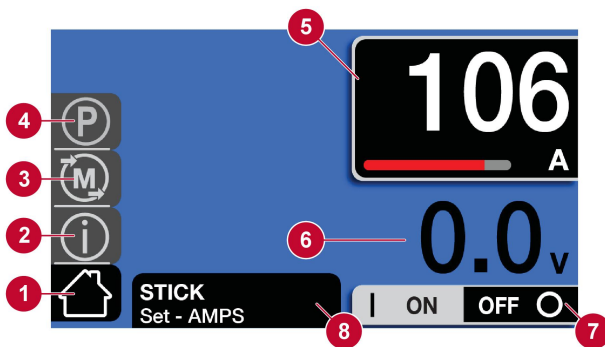

1. Home screen
2. Information
3. Memory
4. Parameter
5. Amperage
6. Power-supply output voltage (Open Circuit Voltage or Arc)
7. Arc ON/OFF
8. Dialogue box

Blue changes to orange when output is "hot".

6.11 DC TIG mode: Basic

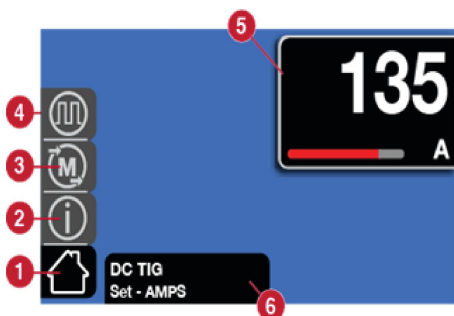

1. Home screen
2. Information
3. Memory
4. Pulse
5. Amperage
6. Dialogue box

6.12 DC TIG mode: Advanced

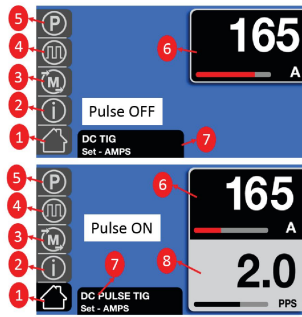

1. Home screen
2. Information
3. Memory
4. Pulse
5. Parameter
6. Amperage
7. Peak time
8. Dialogue box

6.13 AC TIG mode: Basic

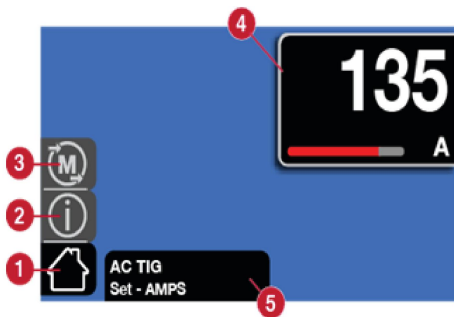

1. Home screen
2. Information
3. Memory
4. Amperage
5. Dialogue box

6.14 AC TIG mode: Advanced

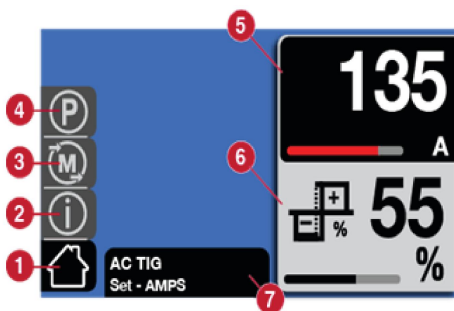

1. Home screen
2. Information
3. Memory
4. Parameter
5. Amperage
6. Balance
7. Dialogue box

6.15 Settings

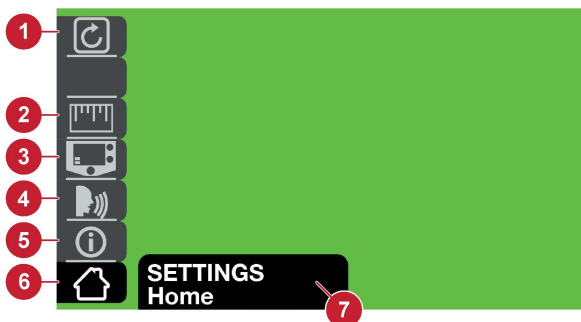

1. Reset modes
2. Inch/Metric
3. Basic/Advanced
4. Language
5. Information
6. Home screen
7. Dialogue box

6.16 User manual information

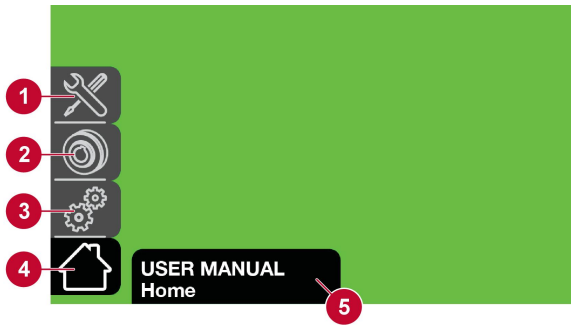

1. Maintenance information
2. Wear/Spare parts
3. Operation information
4. Home screen
5. Dialogue box























6.17 Icon reference guide











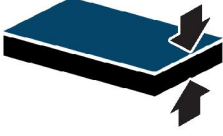



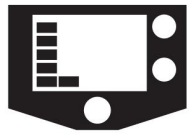



NOTE!

SCT – Short Circuit Termination is a method of automatic burn back at the end of the weld to electrically cut the wire by pulsing high current in a controlled process. The result is a nice clean wire end with no balling or sticking to the weld pool or tip. This allows exceptional restarting of subsequent welds. This feature is primarily for Mild and Stainless steel short-arc welding. For spray and flux core welding, traditional burn back is recommended. When burn back time is set to zero, SCT automatically is enabled. A non-zero burn back setting will disable SCT.

ICON	MEANING	ICON	MEANING
	Home		Spot time on/off selection (use navigation knob and push to select from display)
	Burn back Adjusting the time when the voltage stays on after the wire feed is stopped to keep the wire from freezing in the weld puddle	SCT Selection on display	Short Circuit Termination (SCT: see NOTE above) ON: burnback set to zero OFF: burnback set to non-zero.
	Information		Wire feed speed
	MIG Torch		Spot time on adjustment

ICON	MEANING	ICON	MEANING
	Parameters		Flux cored
	Parameters		Manual MIG
	Percent		STICK
	Pre-flow The time the shielding gas stays on before the welding arc is started		Smart MIG
	Post-flow The time the shielding gas stays on after the welding arc is stopped		Lift-TIG
	Seconds		Saving welding programs for a specific application when in the Memory Mode
	Settings on user manual menu		Cancel
	Spool torch (Not all markets)		Remote
	Settings		Foot control
	2T, Trigger On/OFF		Volts
	4T, Trigger Hold/Lock		User manual on main menu

ICON	MEANING	ICON	MEANING
A	Amps		Plate thickness at sMIG mode
	Arc force On stick welding increasing amps when the arc length is shortened to reduce or eliminate the freezing of the stick electrode in the weld puddle		Trim bar Changing the weld bead profile from flat to convex or flat to concave
	Downslope Sloping the current down over a period of time at the end of the weld cycle		Advanced Settings
	Hot start The increase of amps when striking the electrode to reduce sticking		Basic Settings
	Inductance The addition of inductance into the arc characteristics to stabilize the arc and reduce spatter when in the short circuit process		Language selection
	Memory Ability to save welding programs for a specific application		Stick electrode choice
	Upslope, Sloping the current up over a period of time at the beginning of the weld cycle		Unit of Measure
.8 mm (.030") 	Wire diameter		Bead profile, concave
			Bead profile, convex

6.18 DC TIG Pulse

DC TIG Pulse welding is used mainly on thin metals but can also be used on thicker material based on the application. Pulsing allows the user to control the amount of heat applied to the work piece. Pulse setting gives user far more control over the welding process without compromising the strength and integrity of the weld and helps in having a smooth and clean weld.

Basic Mode:

In basic mode DC TIG pulse has default settings as Back Current = 50 %, Peak Time = 50 %, PPS = 2. User will not be able to adjust these Pulse parameters, in order to adjust these parameters user has to go to advanced mode. Below picture illustration shows the navigation/setup of DC TIG Pulse in basic mode (A-B-C-D).

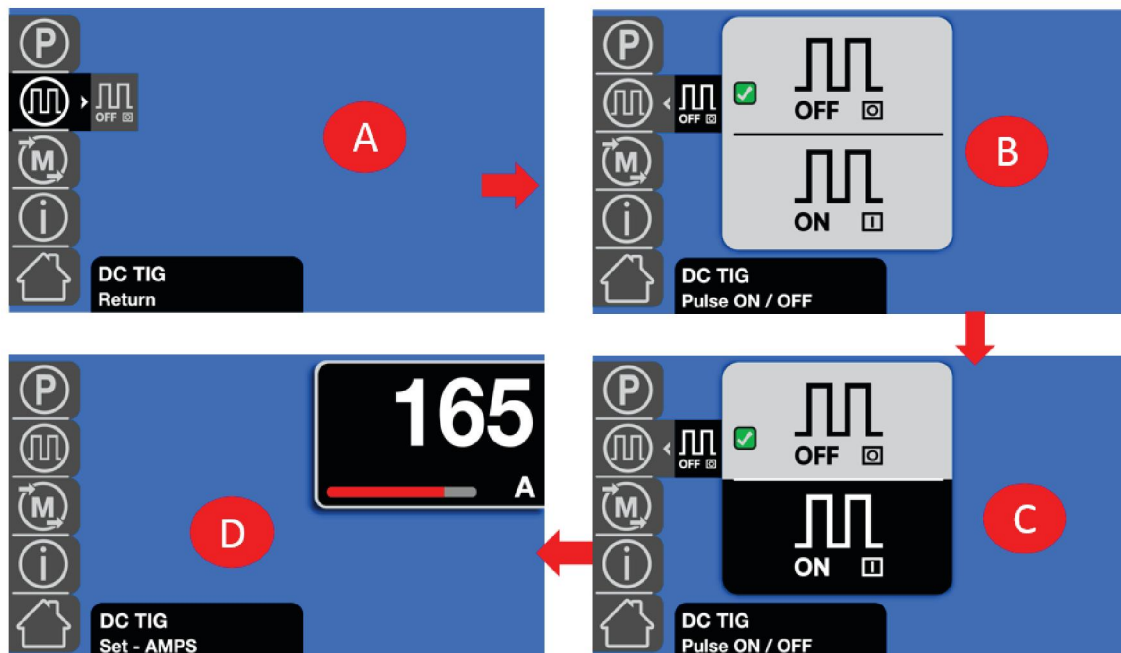

Advanced Mode:

In advanced mode, the user has the ability to adjust the DC Pulse TIG settings as explained below.

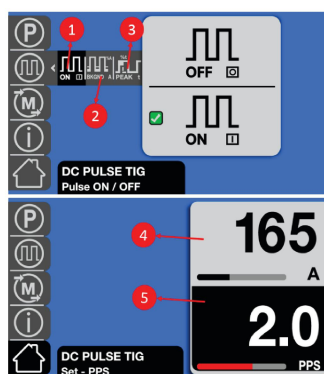

1. Pulse ON/OFF
2. Back Current (%)
3. Peak Time (%)
4. Peak/Set Current (A)
5. PPS (Pulses Per Second)

Back Current (%): Background Current is the amount of the current at which the DC TIG Pulse waveform is in the background time. The back ground current is adjusted in percentage of peak current in the pulse menu. Can be adjusted between 1 and 99 %.

Peak Time (%): The peak time is the time at which the DC TIG Pulse waveform is at peak current. Peak time is adjusted in the percentage quantity of PPS. Can be adjusted between 1 and 99 %.

Peak/Set Current (A): The peak current is set by using the Upper control knob. Can be adjusted between 5 and 205 A.

PPS (Pulses Per Second): The rate at which DC TIG Pulse output current waveform toggles between peak current and background current is set by using the Lower control knob. Can be adjusted between 0.1 and 500.

Below picture illustration shows the navigation/setup of DC TIG Pulse in advanced mode (A-B-C-D-E-F-G-H-I-J).

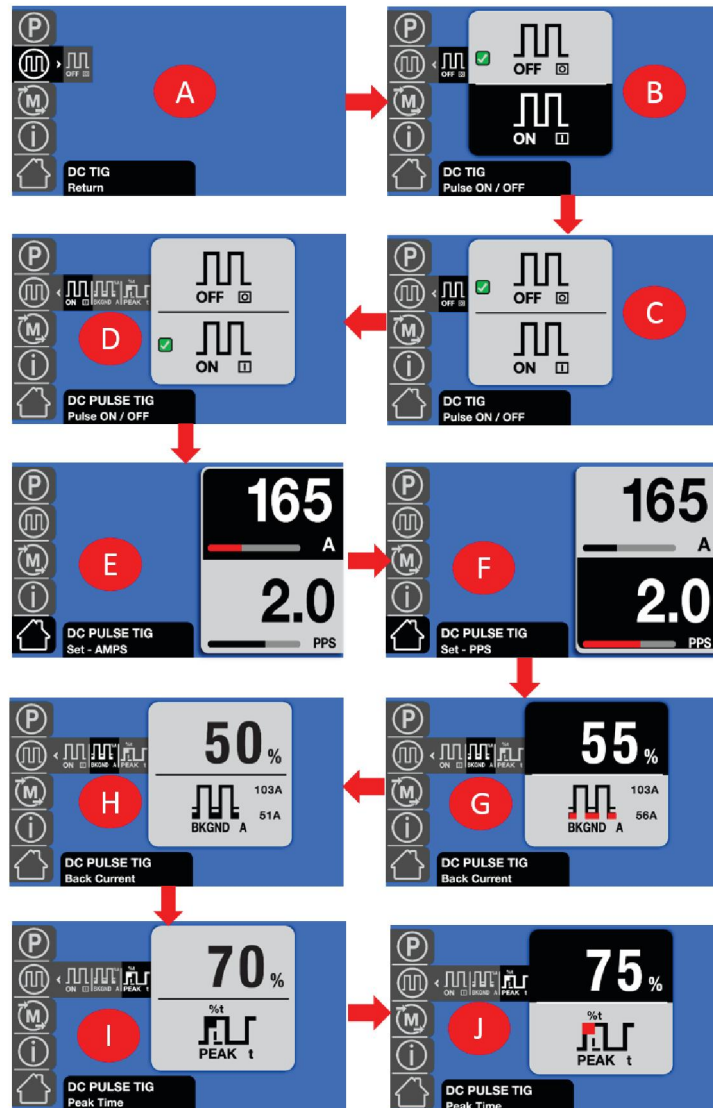

Below picture illustration shows an example of DC TIG output current ideal waveforms in Basic and Advanced modes.

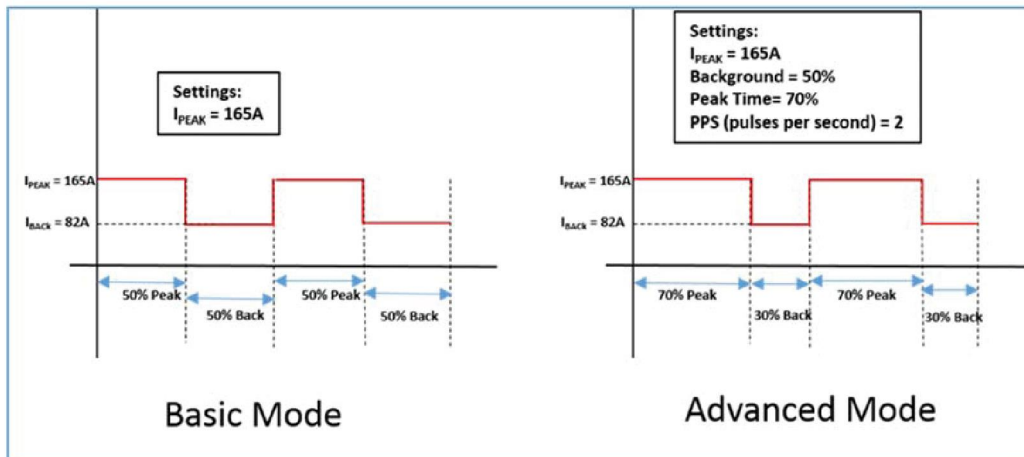

6.19 AC TIG Welding

AC TIG Welding is used mainly for non-ferrous materials like aluminum. In AC TIG Welding the output current polarity is switched between Electrode Positive (EP) and Electrode Negative (EN). In Rebel 205ic AC/DC the switching of output polarity ranges from 25 – 400 Hz. EN polarity provided the welding action and EP polarity provides cleaning action.

Basic Mode:

In basic mode AC TIG has default settings as Pre-Flow = 0.8 sec, Post-Flow = 8 sec, Up-Slope = 0.5 sec, Down-Slope = 0.5 sec, Offset = 0, MIN = 10A, Frequency = 120 Hz, and Balance = 70%. User will not be able to adjust these parameters, in order to adjust these parameters user has to be in advanced mode.

Advanced Mode:

In advanced mode user has the ability to adjust the AC TIG settings as explained below.

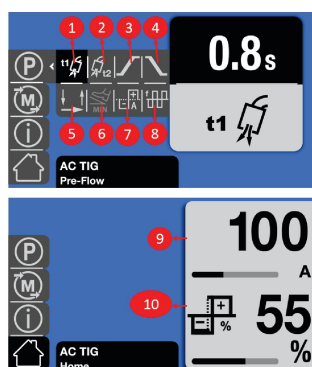

1. Pre-Flow
2. Post-Flow
3. Up-Slope
4. Down-Slope
5. 2T/4T Mode
6. MIN (A)
7. Offset (A)
8. Frequency (Hz)
9. Amperage (A)
10. Balance (%)

MIN (A): MIN current is used when in remote/foot-pedal mode. The default value is 10A, user can adjust this value up to the user set weld current to establish the lower limit.

Up-Slope and **Down-Slope** settings are adjustable only in non-remote/non-foot-pedal mode.

Frequency (Hz): Frequency is the number of times the AC TIG Arc switches between EP and EN in one second. Frequency in Rebel 205 AC/DC machine varies from 25 – 400 Hz with a default value of 120 Hz. Frequency helps in narrowing the weld bead and focus the arc in special application. Higher frequencies narrows the weld bead, has more focused arc and increases the arc stability. In other words the arc cone is much tighter at 400 Hz and focused at the same spot the tungsten electrode is pointing than the arc cone operating at 60 Hz.

Balance (%): Main Screen and lower right encoder is used to adjust the Balance (%) in AC TIG advanced mode. Balance lets you control the arc width, heat, and cleaning action etc.

Benefits of increasing the balance (i.e., increasing the EN portion of the AC TIG waveform):

- Achieve greater penetration
- Helps in increasing travel speeds
- Helps in narrowing the weld bead
- Helps in increasing the tungsten electrode life and reduces balling action
- Reduces the size of etched zone for improved cosmetics

Benefits of decreasing the balance (i.e., increasing the EP portion of the AC TIG waveform):

- Better cleaning action to remove heavier oxidation on the work plate
- Minimizes penetration which help prevent burn-through on thin materials
- Widens the bead profile and helps in catching both sides of the joint



NOTE!

Decreasing the balance to a lower value at a particular weld current will have more balling action on the tungsten, which will reduce the tungsten electrode life and may lose arc stability, so care must be taken when adjusting the balance too low.

Offset (A): Offset feature in AC TIG is used to vary the EP or EN currents to have better cleaning or better penetration respectively without adjusting the balance (duty) and/or user set current. Offset gives the user ability to have a narrower bead with deeper penetration and no visible cleaning action or wider bead with less penetration and clear visible cleaning action based on which direction the Offset is adjusted.

In advanced AC TIG mode, the user can adjust the Offset parameter which will range from - (UserSetCurrent – MIN) to + (UserSetCurrent – MIN). When using a foot pedal, the set value of MIN current affects the usable Offset range. Example, if UserSetCurrent is set to 104 A then the Offset adjustable range is from -94 A to +94 A, because MIN current is 10 A and adding 10 A to 94 A results in 104.

Another example; in the case of Offset set to +15 A with a user set current of 104 A, the weld current drives to EP = 119 A and EN = 89 A as shown in the pictures below.

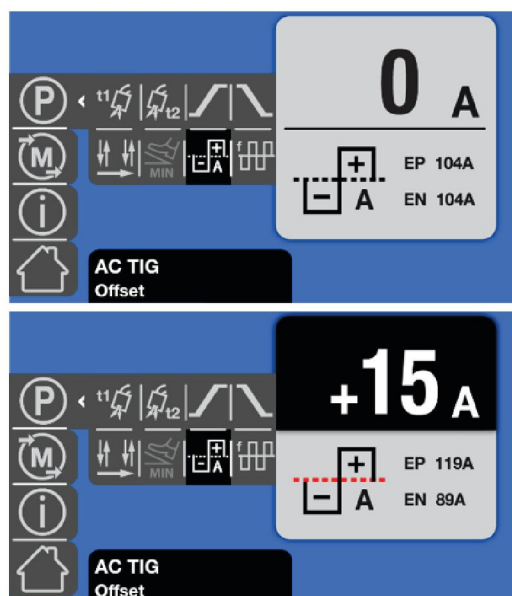

Below picture illustration shows the navigation/setup of AC TIG Welding in advanced mode (A-B-C-D-E-F-G-H-I-J-K).

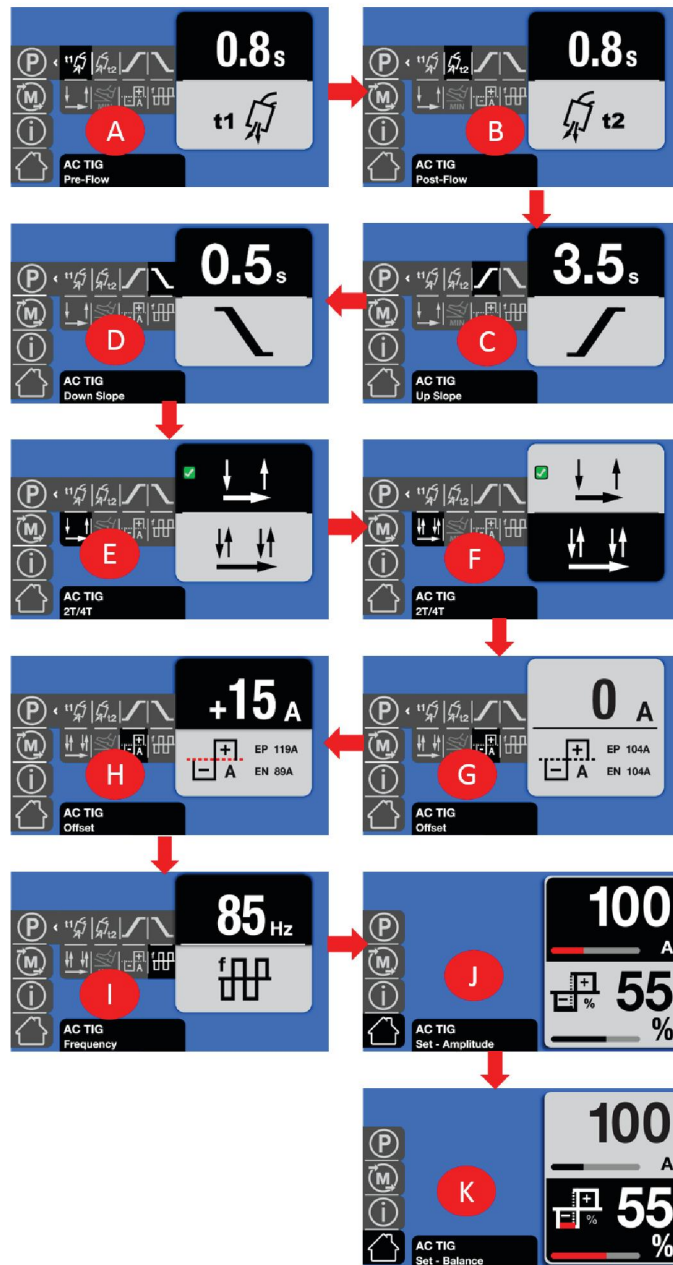

Below picture illustration shows an example of AC TIG output current ideal waveforms in Basic and Advanced modes.

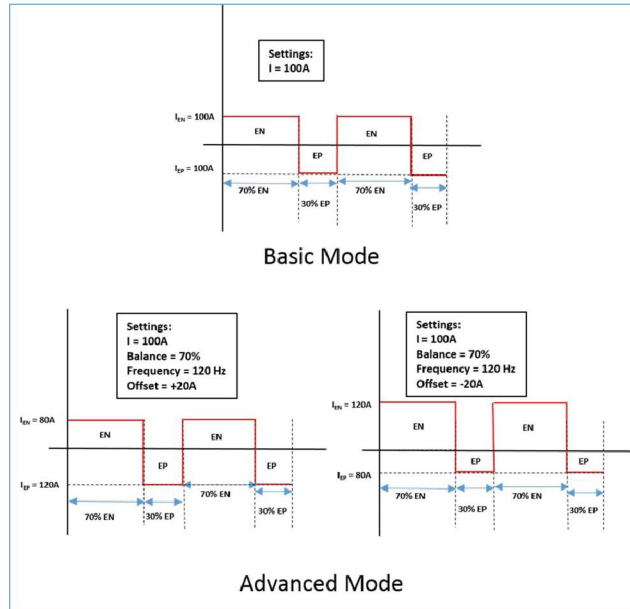

6.20 Lift-TIG welding

2-stroke and 4-stroke welding process illustrated

The trigger is used and some current flows already when lifting away the electrode to strike it.



**2-stroke**

In 2-stroke mode, press the TIG torch trigger switch (1) to start the shielding gas flow and initiate the arc. The current slopes up to the set current value. Release the trigger switch (2) to start to slope down the current and terminate the arc. The shielding gas will continue to flow in order to protect the weld and the tungsten electrode.

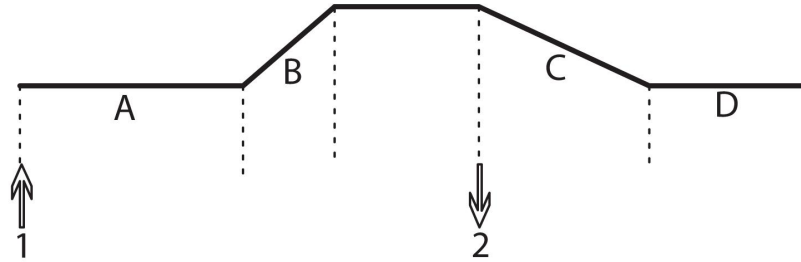

A = Gas pre flow

B = Slope up

C = Slope down

D = Gas post flow

**4-stroke**

In 4-stroke mode, press the TIG torch trigger switch (1) to start shielding gas flow and initiate the arc at a pilot level. Release the trigger switch (2) to slope up the current to the set current value. To stop the welding, press the trigger switch again (3). The current will slope down to the pilot level again. Release the trigger switch (4) to terminate the arc. The shielding gas will continue to flow in order to protect the weld and the tungsten electrode.

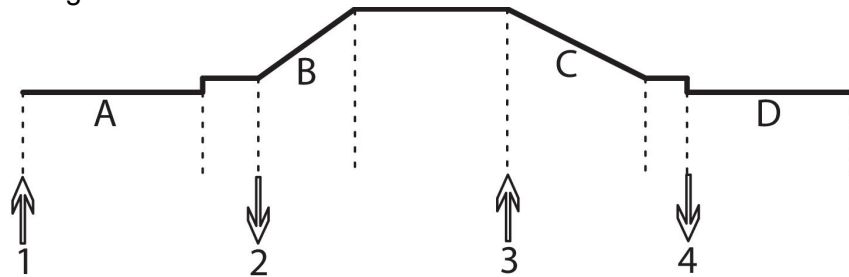

A = Gas pre-flow

B = Slope up

C = Slope down

D = Gas post-flow

7 MAINTENANCE



WARNING!

Disconnect power before performing maintenance.



CAUTION!

Only persons with the appropriate electrical knowledge (authorised personnel) may remove the cover of this product or carry out service, maintenance or repair.



CAUTION!

This product is covered by manufacturer's warranty. Any attempt to carry out repair work by non-authorised service centres will invalidate the warranty.



CAUTION!

Before each use, make sure:

The torch body and torch cable and leads are not damaged.

The contact tip on the torch is not damaged.

The nozzle on the torch is clean and does not contain any debris.



NOTE!

Perform maintenance more often during severe dusty conditions.







NOTE!

There are no user serviceable parts inside of the power supply side of the EMP unit. Any need for service on the electronics/electrical-power side should be referred to the nearest ESAB service center.

7.1 Routine maintenance

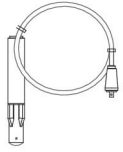
Maintenance schedule during normal conditions:

Interval	Area to maintain		
Every 3 months	 Clean or replace unreadable labels.	 Clean weld terminals.	 Check or replace weld cables.
Every 6 months	 Clean inside equipment.		

7.2 Wire-feeder assembly maintenance

General good practice is to perform this procedure each time a wire bobbin is replaced.

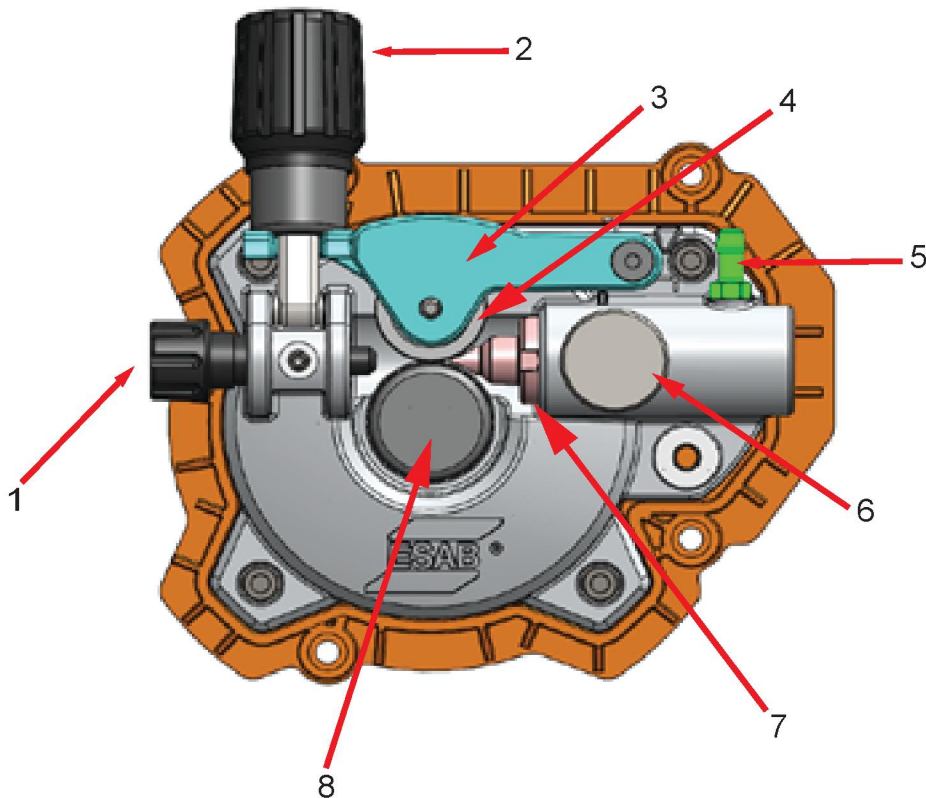

Figure 16. Wire-feeder assembly parts

- | | |
|---------------------|---|
| 1. Inlet wire guide | 5. Gas inlet |
| 2. Tension knob | 6. MIG torch locking knob |
| 3. Pressure arm | 7. Outlet wire guide |
| 4. Pressure roller | 8. Wire feed roller (behind locking knob) |

7.2.1 Wire-feeder assembly cleaning



WARNING!

Always use hand and eye protection when cleaning.

1. Disconnect the electrical power source from the unit.
2. Open the cover on the wire-bobbin side of the EMP unit.
3. Before moving the tension knob: note its numerical setting as indicated on its body right below the handle. Record this number to reset the tension in its approximate range. Section "Setting wire-feed pressure" describes the fine adjustment for this tension adjustment.



NOTE!

Since the wire-feed pressure adjustment may be disturbed to release this arm, the tension on the rollers will have to be re-adjusted at the end of this procedure. Recording the undisturbed scale number in the previous step facilitates the process at the end of the procedure to accurately set the tension.

4. Release the tension from the pressure rollers by turning the tension knob on the tension arm counter-clockwise enough to pull it first up (out of its detent slot) and then toward you (see 1 in illustration above). The tension arm will spring-up as soon as the tension arm is released. This should free the wire movement to remove the wire in the next step.
5. Using (as needed) either soft-bristle brush or use a forced air source by blowing compressed air (max. 5 bar) to remove all debris which may have accumulated in this space. WEAR EYE PROTECTION.
6. Inspect if the input wire-feed guides and the feed rollers for wear and need replacement. See "WEAR PARTS" section for ordering wear-part numbers. See "Removing wire-feed roller" subsection in "Removing/Installing wire-feed roller" section in the "OPERATION" chapter. If none need replacement – only cleaning – go to the next step.

**CAUTION!**

When removing the roller be careful **not** to lose the drive-shaft key on the motor shaft. Failure to comply will render the entire unit useless until this part is replaced.

7. Clean the wire-feed roller with a soft brush.
8. Clean the pressure roller attached to the tension arm with a soft brush.
9. Close the tension arm on to the wire in its groove on the wire-feed rollers.

**NOTE!**

Verify that the wire is in its groove and not floating out of the groove on the roller surface.

10. Visually verify that the wire appears as a straight line through the entire wire-feed assembly.

**NOTE!**

The bobbin may be turned counter-clockwise to take up any slack. Do this only **AFTER** step 12 because the tension on the wire is the only force preventing the movement of the wire at the torch tip.

11. Visually verify that the wire protrudes per specification at the torch tip and has not been pulled into the torch head.
12. Adjust the wire-feed pressure by adjusting the tension on the wire at the wire-feed rollers by turning the tension knob using the procedure in "Setting wire-feed pressure" subsection in "OPERATION" chapter.
13. Close the cover on the wire-bobbin side of the EMP unit.

7.3 EMP-unit power side maintenance

**NOTE!**

There are no user-serviceable parts on the power-side. In dusty environments, the power-side should be checked periodically for any dust/debris accumulation because of the fan forced-air cooling used on this side.

Because of the electro-static sensitive components and exposed circuit boards any maintenance on this side should be done by an authorized ESAB service technician.

7.4 Torch liner maintenance

Refer to MIG torch instruction manual for replacing standard steel torch conduit liner with a Teflon torch conduit liner.

- Model EMP 205ic AC/DC uses torch model: Tweco® Fusion™ 180 A MIG torch with 10 ft (3 m) cable / Tweco® pigtail with 0.023 in. (0.6 mm), 0.030 in. (0.8 mm), 0.035 in. (0.9 mm) contact tip and Operator manual all in one bag.

7.4.1 Torch liner cleaning

1. Disconnect the power source from the input power socket.
2. Disconnect the torch assembly from the unit.
3. Remove the wire from the torch wire-liner by pulling the wire out from the torch wire-liner and laying it neatly for re-installation at the end of this procedure.
4. Remove the liner from the torch hose and inspect it for damage or kinks. Clean the liner by blowing compressed air (max. 5 bar) through the end of the liner that was mounted closest to the unit.
5. Re-install the liner.
6. Re-install the wire through the wire-feed assembly until visible at the torch tip. Verify that the wire does correctly feed out of the torch.

8 TROUBLESHOOTING

8.1 Preliminary checks

Try these checks and inspections before sending for an authorized service technician.

Before attempting to troubleshoot the ESAB Rebel it is recommended to first perform a WELD DATA RESET (navigate to HOME/SETTING/RESET/WELD DATA RESET). A WELD DATA RESET of the system will restore the unit to its default welding condition. Performing this Reset will not lose any user stored memory values but will establish a baseline from which all troubleshooting should start. If the WELD DATA RESET is not successful it is recommended to perform a Factory Reset and repeat testing.



CAUTION!

A Factory Reset will also erase all user stored memory locations. If this does not correct the problem, follow the table where possible.

Type of fault	Corrective action
Porosity within the weld metal	<ul style="list-style-type: none"> • Check gas bottle is not empty. • Check gas regulator is not closed. • Check gas inlet hose for leaks or blockage. • Check that the correct gas is connected and the correct gas flow is used. • Keep the distance between the MIG torch nozzle and the work piece to a minimum. • Do not work in areas where drafts, which would disburse the shielding gas, are common. • Make sure the work piece is clean, with no oil or grease on the surface, before welding.
Wire feeding problems	<ul style="list-style-type: none"> • Make sure the wire spool brake is adjusted correctly. • Make sure the feed roller is correct size and not worn. • Make sure the correct pressure is set on the feed rollers. • Make sure the proper direction of motion is set based on the wire type (into the weld pool for aluminum, away from the weld pool for steel). • Make sure the correct contact tip is used and it is not worn. • Make sure liner is the right size and type for wire. • Make sure the liner is not bent so that friction is caused between the liner and the wire.
MIG (GMAW/FCAW) welding problems	<ul style="list-style-type: none"> • Make sure the MIG torch is connected to the correct polarity. Refer to the electrode wire manufacturer for the correct polarity. • Replace contact tip if it has arc marks in the bore causing excessive drag on the wire. • Make sure the correct shielding gas, gas flow, voltage, welding current, travel speed and MIG torch angle is used. • Make sure the work lead has proper contact with the work piece.
MMA (SMAW) basic welding problems	<ul style="list-style-type: none"> • Make sure you are using the correct polarity. The electrode holder is usually connected to the positive polarity and the work lead to the negative polarity. If in doubt, consult the electrode data sheet.

Type of fault	Corrective action
TIG (GTAW) welding problems	<ul style="list-style-type: none"> • Make sure the TIG torch is connected to the power source: Connect the TIG torch to the negative [-] welding terminal. Connect the welding ground cable to the positive [+] welding terminal. • Use only 100% Argon gas for TIG welding. • Make sure the regulator/flow meter is connected to the gas bottle. • Make sure the gas pipe for the TIG torch is connected to the gas outlet connector on the front of the power source. • Make sure the work clamp has proper contact with the work piece. • Make sure the gas bottle is opened and check the gas flow rate on the regulator/flow meter. The flow rate should be between 10 – 25 CFH (4.7 – 11.8 l/min). • Make sure the power source is turned on and TIG welding process is selected. • Make sure all connections are tight and leak-free.
No power/No arc	<ul style="list-style-type: none"> • Check that the input power supply switch is turned on. • Check if a temperature fault is shown on display. • Check if system breaker is tripped. • Check that the input power, welding and return cables are correctly connected. • Check that the correct current value is set. • Check the input power supply fuses/breakers.
The overheating protection trips frequently.	<ul style="list-style-type: none"> • Make sure that you are not exceeding the recommended duty cycle for the weld current you are using. See the "Duty cycle" section in the "OPERATION" chapter. • Make sure the air inlets or outlets are not clogged. • Make sure fans are operating when welding.

8.2 User interface (UI) software displayed error codes

The following table exhibits fault codes that may appear to assist in troubleshooting.

Severity Level Meaning (see **Severity Level** Column in table):

- **(C)** Critical Service Required - Unit not functional or locked, not recoverable
- **(NC)** Non-Critical - Service may be desired - unit functional with limited performance
- **(W)** Warning - Unit functional and will recover on its own

Error Code	Severity Level	Functional Circuit Failure Explanation
001	W	PFC Heatsink, IGBT Heatsink or Main transformer has overheated >185 °F (85 °C).
002	W	Output diode Temperature fault, Analog temperature sensor.
003	W/C	Warning - If occurred during load/arc-start, cause is due to low input AC volts - Err009 Critical - If occurred at power-up under no-load condition. DC Bus (400 V) fault droop under load, PFC not supplying 400 V to inverter.
004	C	Output voltage is above VRD levels when VRD switch is active.
005 – 007		(reserved)
008	C	OCV error, Output voltage not sensed at Control Board CN1 as expected
009	W	Low Voltage Error, AC Mains voltage is less than 108 V AC, this could trip Err 003
010		(reserved)
011	C	User has attempted a parameter or factory reset, and this was not confirmed by the system.
012	C	Communication Link Down, no communication between UI and Ctrl PCB at CN6
013	C	Low Internal Power Supply (IPS) Voltage Error, +24 V IPS is less than 22 V DC
014	C	Secondary Current Sensor output not detected at Control PCB CN18
015	C	Communication Link Down, no communication between Ctrl PCB at CN14 and AC DC inverter PCB at CN3
016	C	AC DC Inverter Temperature fault, Analog temperature sensor
017 – 019		(reserved)
020	C	No Image found in Flash
021	C	The image read from the flash is corrupted
022	NC	Failed two attempts of saving user memory to permanent memory in SPI Flash.
023	NC	Failed two attempts of recovering user memory permanent memory from SPI Flash.

9 ORDERING SPARE PARTS



CAUTION!

Repair and electrical work should be performed by an authorised ESAB service technician. Use only ESAB original spare and wear parts.

The EMP 205ic AC/DC is designed and tested in accordance with international standards **IEC-/EN 60974-1, IEC-/EN 60974-3, IEC-/EN 60974-5, IEC-/EN 60974-7, IEC-/EN 60974-11, IEC-/EN 60974-12 and IEC-/EN 60974-13**. It is the obligation of the authorized service centre carrying out the service or repair work to ensure that the product still conforms to the aforementioned standards.

Spare parts and wear parts can be ordered through your nearest ESAB dealer, see the back cover of this document. When ordering, please state product type, serial number, designation and spare part number in accordance with the spare parts list. This facilitates dispatch and ensures correct delivery.

DIAGRAM

Functional block diagram

Schematic

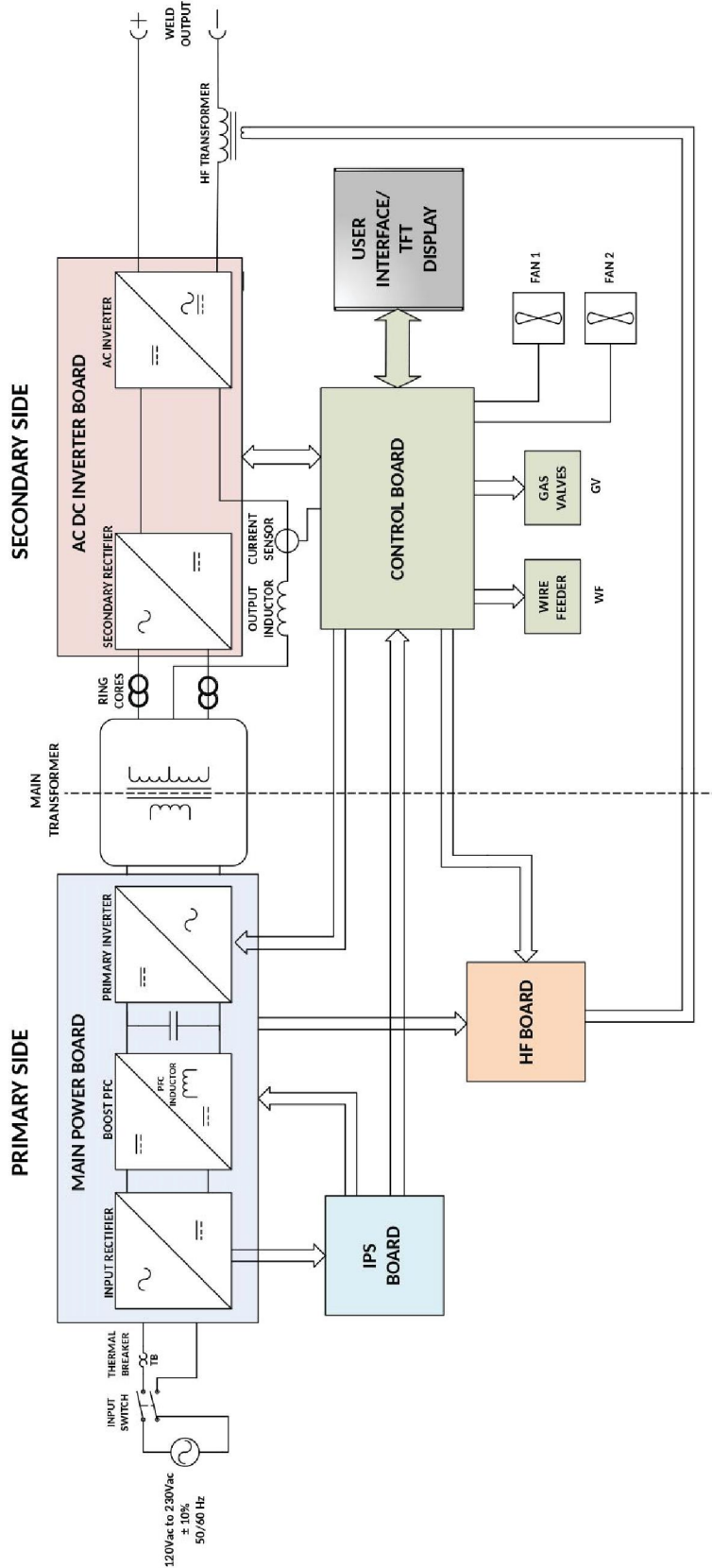

ORDERING NUMBERS



Ordering no.	Description	Note
0558 102 553	EMP 205ic AC/DC	Bobbin size 4–12 in. (100–300 mm)
0463 661 001	Spare Parts List	

WEAR PARTS

Certain mechanical parts on the wire-feed assembly are subject to more frequent use hence may wear more frequently. These are exhibited here.

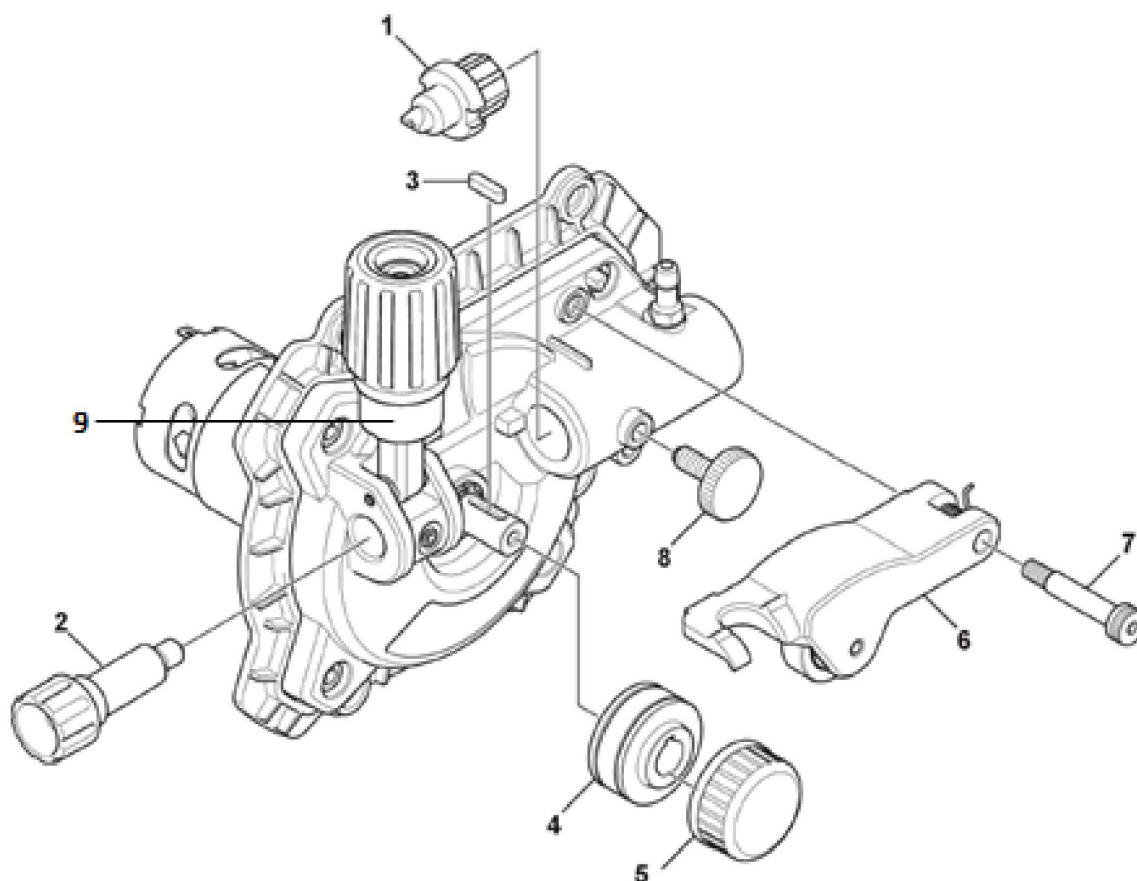

Item	Ordering no.	Description	Wire type	Wire dimensions
1	0558 102 326	Wire outlet guide	Fe/SS/Flux	0.030" (0.8 mm) 0.035" (0.9 mm) 0.045" (1.2 mm)
1	0558 102 327	Wire outlet guide	Fe/SS/Flux	0.024" (0.6 mm)
2	0558 102 328	Wire inlet guide	Fe/SS/Flux	0.024" (0.6 mm) 0.030" (0.8 mm) 0.035" (0.9 mm) 0.045" (1.2 mm)
3	0558 102 334	Key-drive shaft	N/A	N/A
4	7977036	Feed roll "V" groove	Fe/SS	0.024" (0.6 mm) 0.030" (0.8 mm)
5	0558 102 329	Locking knob	N/A	N/A
6	0558 102 331	Pressure arm assembly	N/A	N/A
7	0558 102 332	MIG torch locking knob	N/A	N/A
8	0558 102 329	Tension knob assembly	N/A	N/A

ACCESSORIES

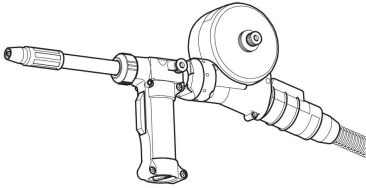
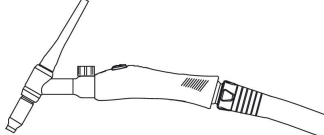
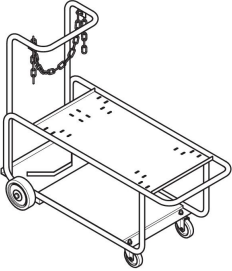
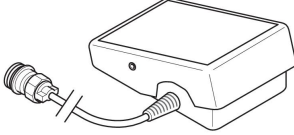
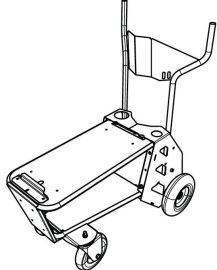
1027-1397	Spool gun 160 A, 12 ft (3.6 m), suits 4 in. (100 mm) spools	
W4014603	TIG Torch (for EMP only) 26 V, 12.5 ft, 8-pin & accessory Kit	
0558102325	Basic utility cart Accommodates maximum 7 in. (177.8 mm) diameter cylinder	
W4014450	Foot control Contactor on/off and current control with 15 ft (4.6 m) cable and 8-pin male plug	
0558102491	Rebel single cylinder cart Accommodates 1 × 9 in. (228.6 mm) diameter cylinder	

REPLACEMENTS PARTS

EMS and EMP series

Item	Ordering no.	Denomination
1	1017-1338	Tweco® Fusion™ 180 A MIG gun, 10 ft (3 m)
2	W4013802	Tweco® 17V TIG torch 12.5 ft (4 m), 8 pin and accessory kit
3	WS200E13	Tweco® 200 A electrode holder & lead assembly, 13 ft (4 m), 50 mm dinse
4	WS200G10	Tweco® 200 A ground clamp & lead assembly, 10 ft (3 m), 50 mm dinse
5	W4013900	Gas hose, 12.5 ft (3.8 m) Male 5/8-18UNF
6	W4014000	Power adapter (230 V – 120 V, 15 A)

ROLLER & WIRE-GUIDE SELECTION

Roller selection

Item	Ordering no.	Description Values = Wire diameter	Comment
Feed rollers for steel wire			
1	0459 052 003	ROLLER, .040 (1.0) – .045 (1.2), V-SOLID	DEFAULT*
2	0459 052 002	ROLLER, .030 (.8) – .040 (1.0), V-SOLID	ACCESSORY**
3	0458 825 002	ROLLER, .045 (1.2) – .052 (1.4), V-KNURLED	ACCESSORY**
4	0458 052 001	ROLLER, .024 (.6) – .030 (.8), V-SOLID	OPTIONAL FOR PURCHASE
5	0459 052 013	ROLLER, .052 (1.4) – .062 (1.6), V-SOLID	OPTIONAL FOR PURCHASE
Feed rollers for aluminum wire			
6	0458 824 002	ROLLER, .040 (1.0) – .045 (1.2), ALUM (U-GROOVE)	OPTIONAL FOR PURCHASE
7	0458 824 003	ROLLER, .045 (1.2) – .062 (1.6), ALUM (U-GROOVE)	OPTIONAL FOR PURCHASE
8	0458 824 001	ROLLER, .030 (0.8) – .040 (1.0), ALUM (U-GROOVE)	OPTIONAL FOR PURCHASE
* DEFAULT (size included in package)			
** ACCESSORY (optional size included with each model)			

Wire-guide selection

Item	Ordering no.	Description Values = Inner diameter (ID) of tubes	Comment
Output wire-guide tubes for steel wire			
1	0558 102 582	TUBE, WIRE GUIDE .040 (1.0) - .045 (1.2), V-SOLID	DEFAULT*
2	0558 102 584	TUBE, WIRE GUIDE .030 (.8) - .040 (1.0), V-SOLID	ACCESSORY**
3	0558 102 585	TUBE, WIRE GUIDE .024 (.6), V-SOLID	OPTIONAL FOR PURCHASE
4	0558 102 583	TUBE, WIRE GUIDE .052 (1.4) - .062 (1.6), V-SOLID	ACCESSORY**
Output wire-guide tubes for aluminum wire			
5	0558 102 586	TUBE, WIRE GUIDE .040 (1.0), ALUM	OPTIONAL FOR PURCHASE
6	0558 102 587	TUBE, WIRE GUIDE .045 (1.2), ALUM	OPTIONAL FOR PURCHASE
7	0558 102 588	TUBE, WIRE GUIDE .052 (1.4) – .062 (1.6), ALUM	OPTIONAL FOR PURCHASE
* DEFAULT (size included in package)			
** ACCESSORY (optional size included with each model)			



A WORLD OF PRODUCTS AND SOLUTIONS.



For contact information visit esab.com

ESAB AB, Lindholmsallén 9, Box 8004, 402 77 Gothenburg, Sweden, Phone +46 (0) 31 50 90 00

<http://manuals.esab.com>

