

Exceed Hack Squat



Description

The Bench Fitness Exceed Hack Squat, is built using the strongest and most durable materials, constructed from 75 x 100 and 75 x 75 heavy duty frame with 30mm guide rods and enclosed linear bearings.

The Bench Fitness Exceed Hack Squat offers a huge amount of adjustability with a 5 position adjustable foot platform with calf raise removable insert, additional hand grips wrapping around the bottom of the rear back rest and 11 position stopper allowing you to finely adjust your lowest stop point.

Comes with both a 35 degree and 45 degree upright and bracket kit, so the Exceed Hack Squat can be set up at your choice of angle during assembly.

Set up at 45 degree, empty load weight starts at 35kgs, setup at 35 degree, empty load weight starts at 30kg with a total max capacity of 350kgs. Suitable for user heights from 150cm to 210cm.

Custom frame colours available.



Removeable calf raise foot plate

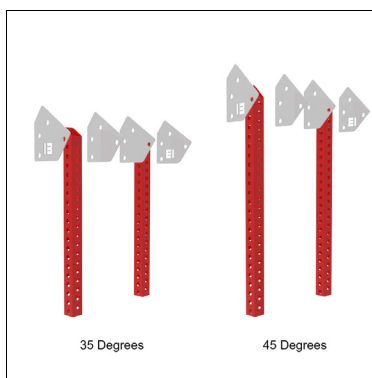

35° & 45° degree kit included



Dual safety stop adjusters

Features

- 30mm guide rods with linear bearings
- 30kg unloaded starting weight
- 2 position lock
- 5 position foot platform
- 11 position safety stop
- Suits 150cm - 210cm athlete

Specifications

Material:	75 x 75 / 75 x 100 Tube frame
Length:	2736mm
Height:	1532mm (45°) 1285mm (35°)
Width:	765mm (frame) 1503mm (weight horns)
Weight:	304 KG



Exceed Hack Squat



Dimensions

35°

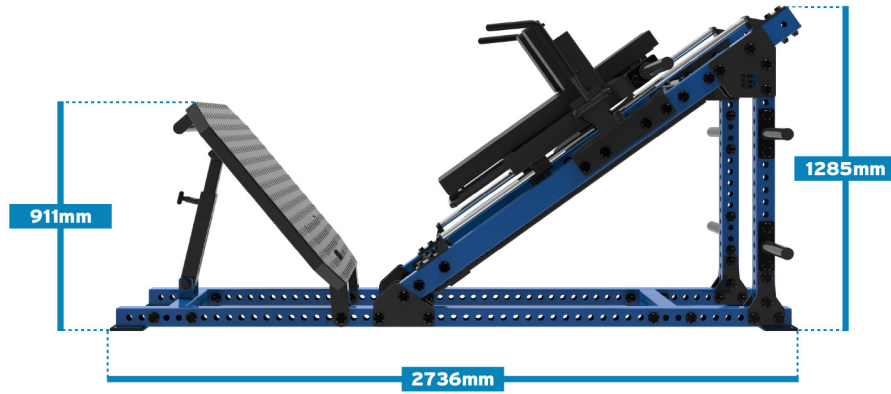

45°

