

YJ REAR INNER FENDER HIGHLINE 15" STRETCH

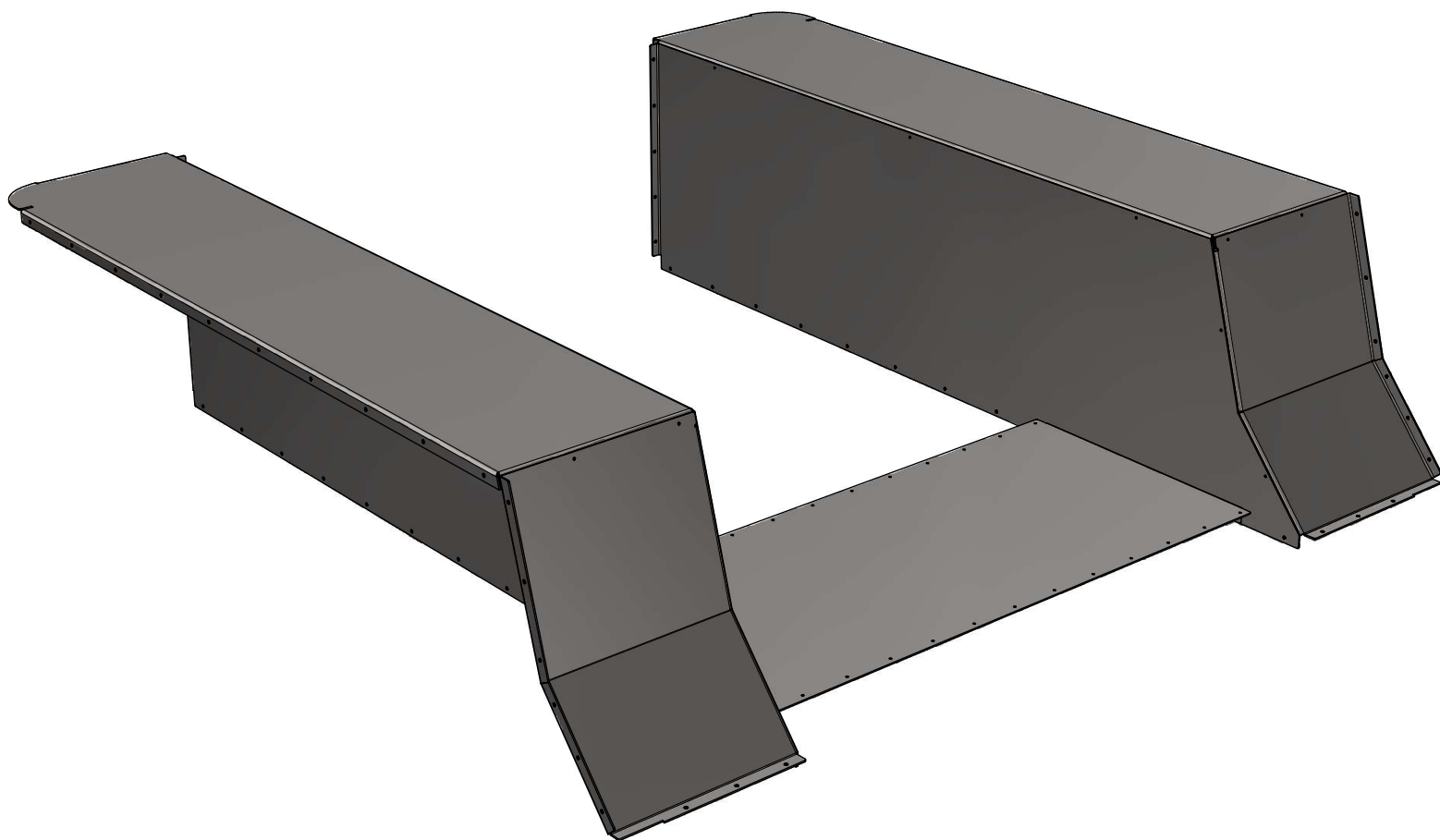

ASSEMBLY INSTRUCTIONS

MB5529 - Assembly Instructions YJ Rear Inner Fenders - Highline 15' Stretch

KIT COMPONENTS

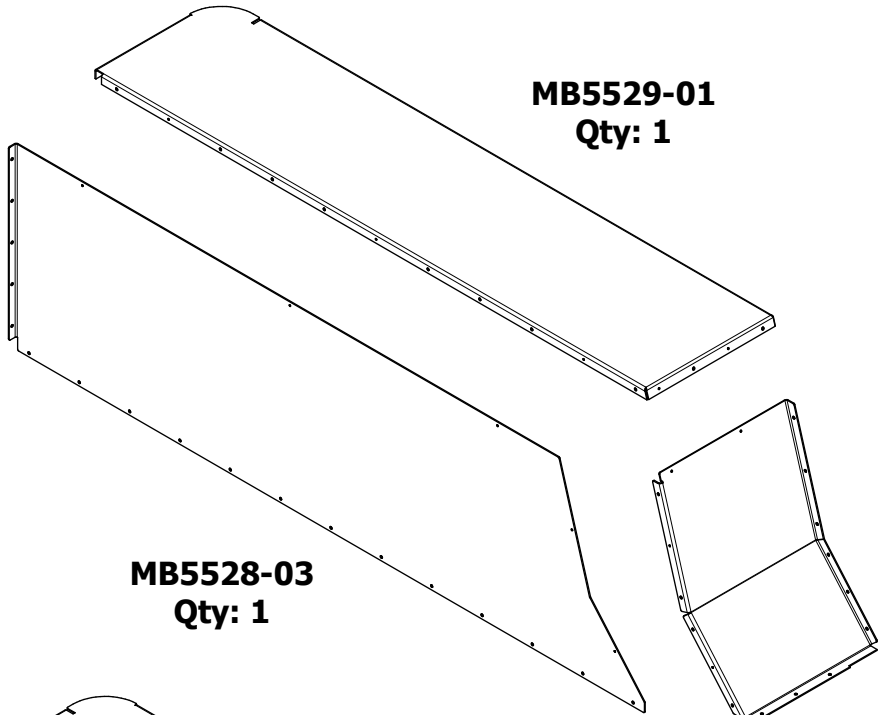

**MB5529-01
Qty: 1**

**MB5528-03
Qty: 1**

**MB5529-02
Qty: 1**

**MB5528-01_MIR
Qty: 1**

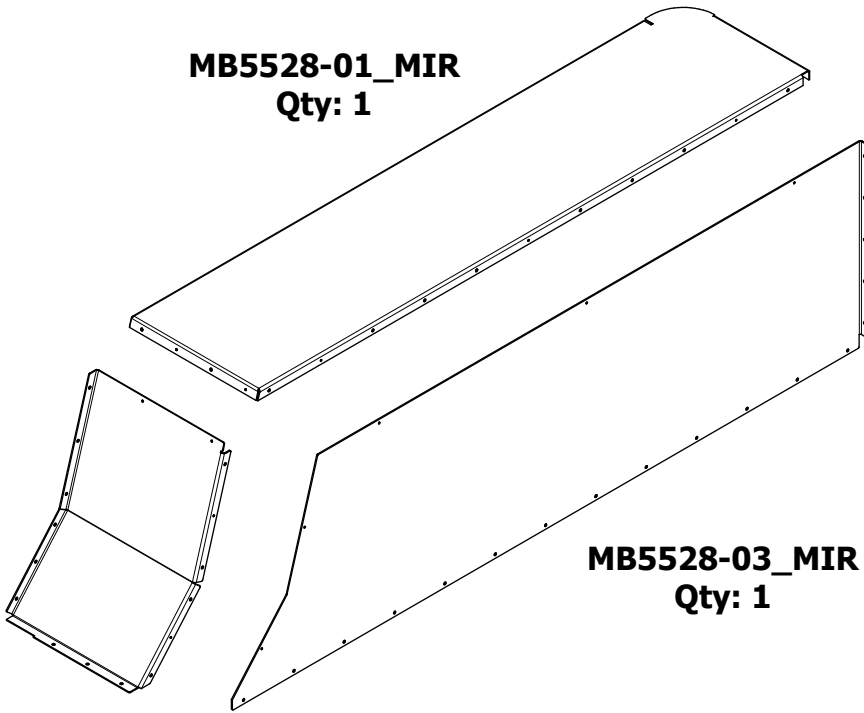

**MB5528-03_MIR
Qty: 1**

**MB5528-02_MIR
Qty: 1**

MB5529 - Assembly Instructions YJ Rear Inner Fenders - Highline 15' Stretch

BODY MODIFICATION

THE BODY STRUCTURE OF THE JEEP WILL BE SIGNIFICANTLY WEAKENED DURING CUTTING. ADD SUPPORT TO THE BODY TO PREVENT DEFORMATIONS WHILE CUTTING AND REPOSITIONING THE BODY.

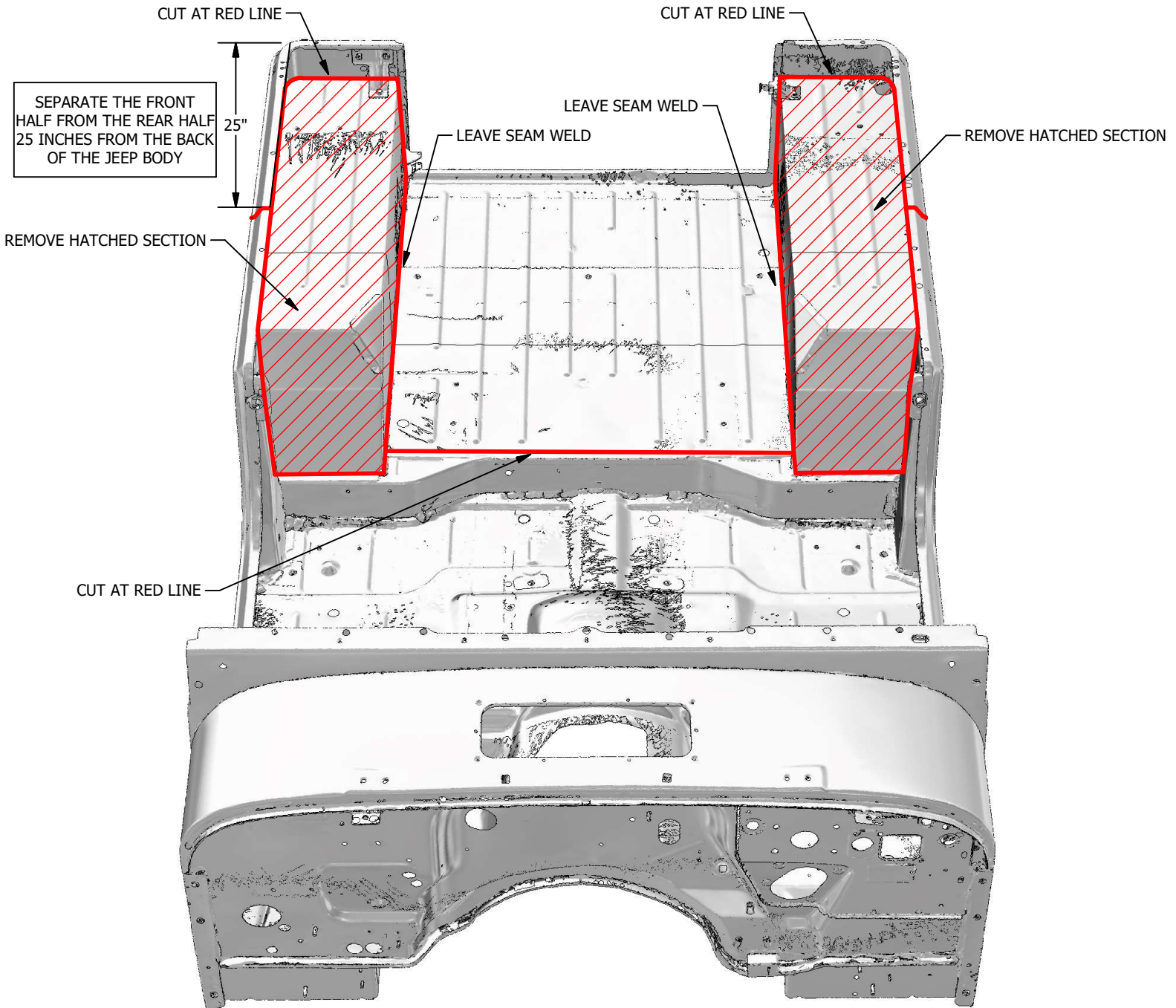

MB5529 - Assembly Instructions YJ Rear Inner Fenders - Highline 15' Stretch

BODY MODIFICATION

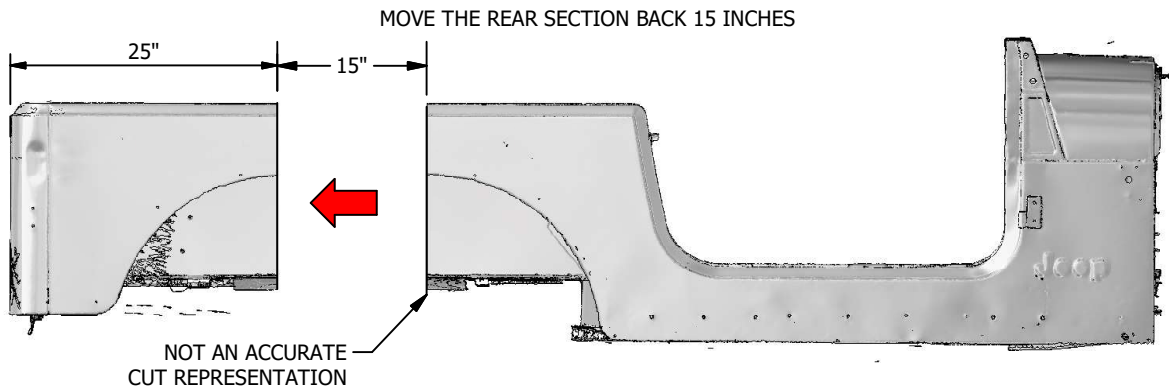
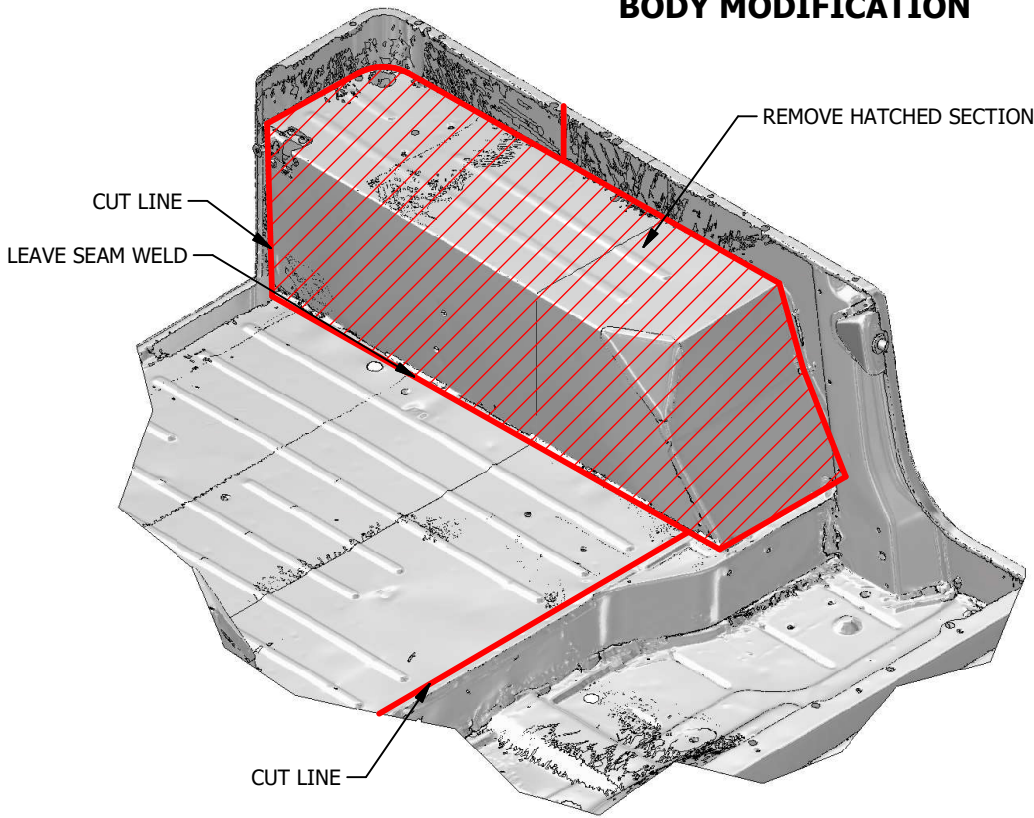

AFTER CUT AND STRETCH



MB5529 - Assembly Instructions YJ Rear Inner Fenders - Highline 15' Stretch

FLOOR PLATE INSTALLATION

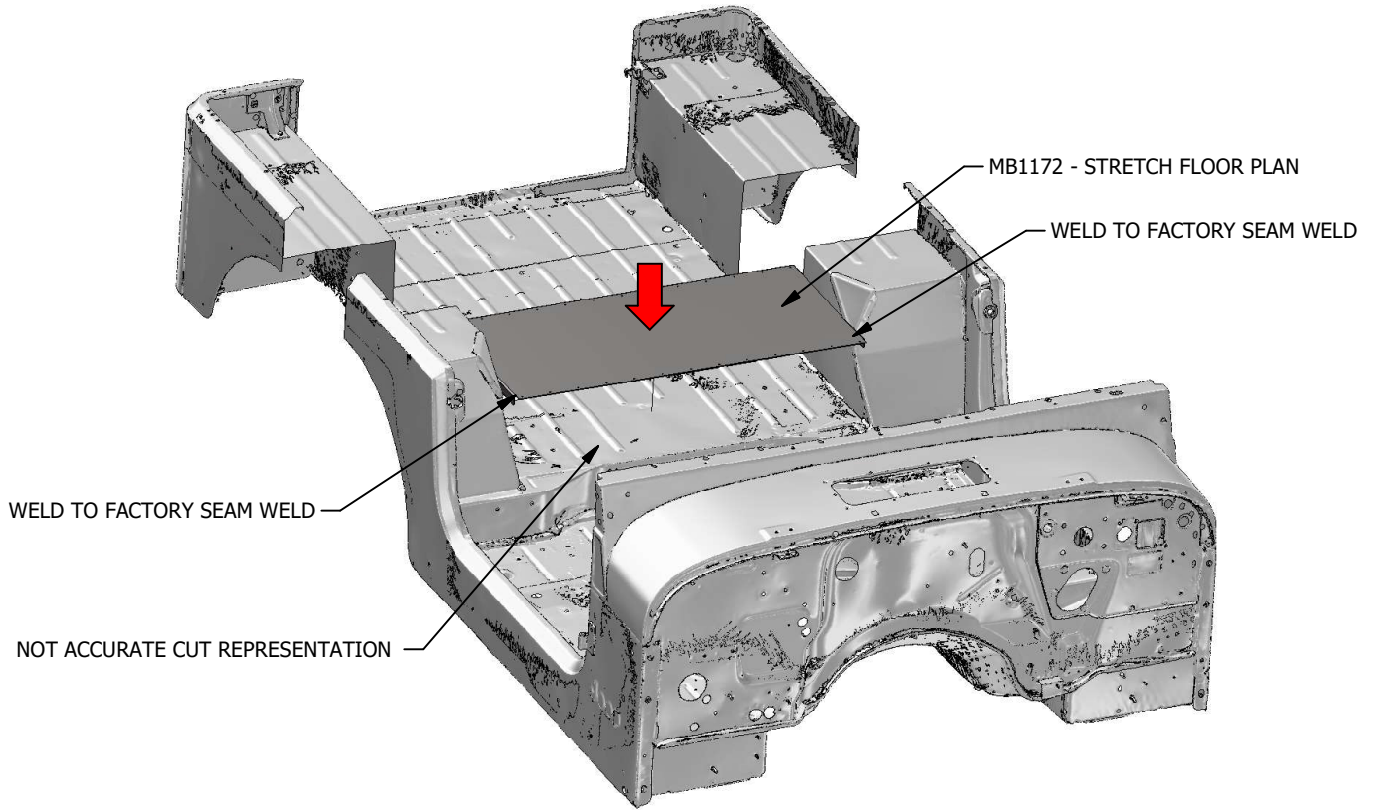

MB5529 - Assembly Instructions YJ Rear Inner Fenders - Highline 15' Stretch

INNER FENDER ASSEMBLY

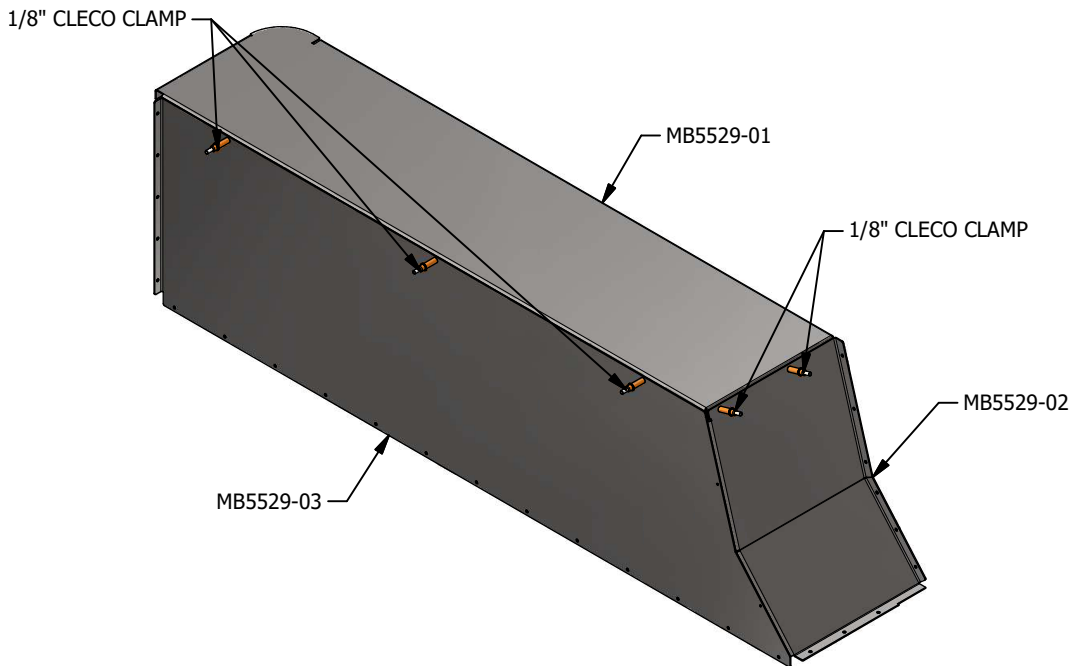
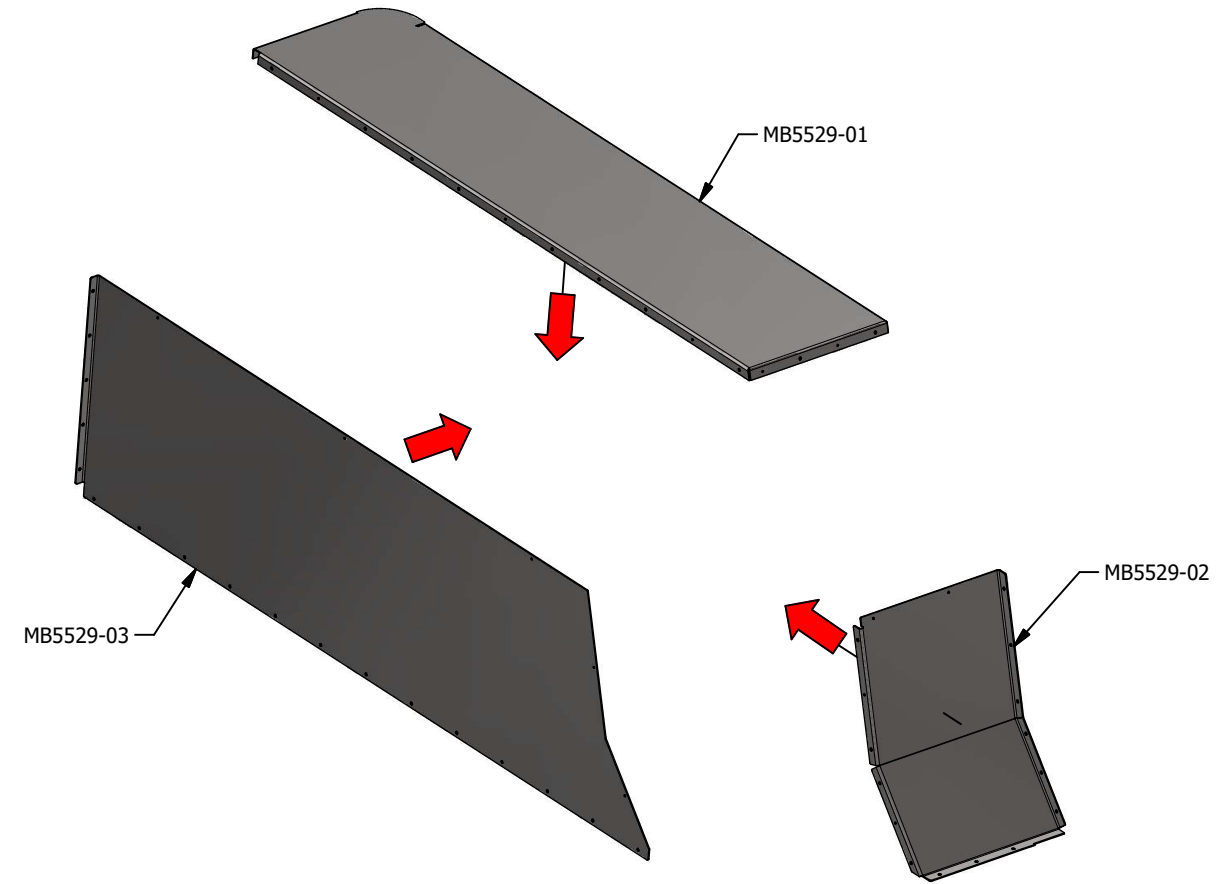

ASSEMBLED

MB5529 - Assembly Instructions YJ Rear Inner Fenders - Highline 15' Stretch**INNER FENDER ASSEMBLY**

REMOVE CLECO CLAMPS ONCE IN VEHICLE
AND WELD ASSEMBLY TOGETHER AND TO
THE FACTORY JEEP BODY

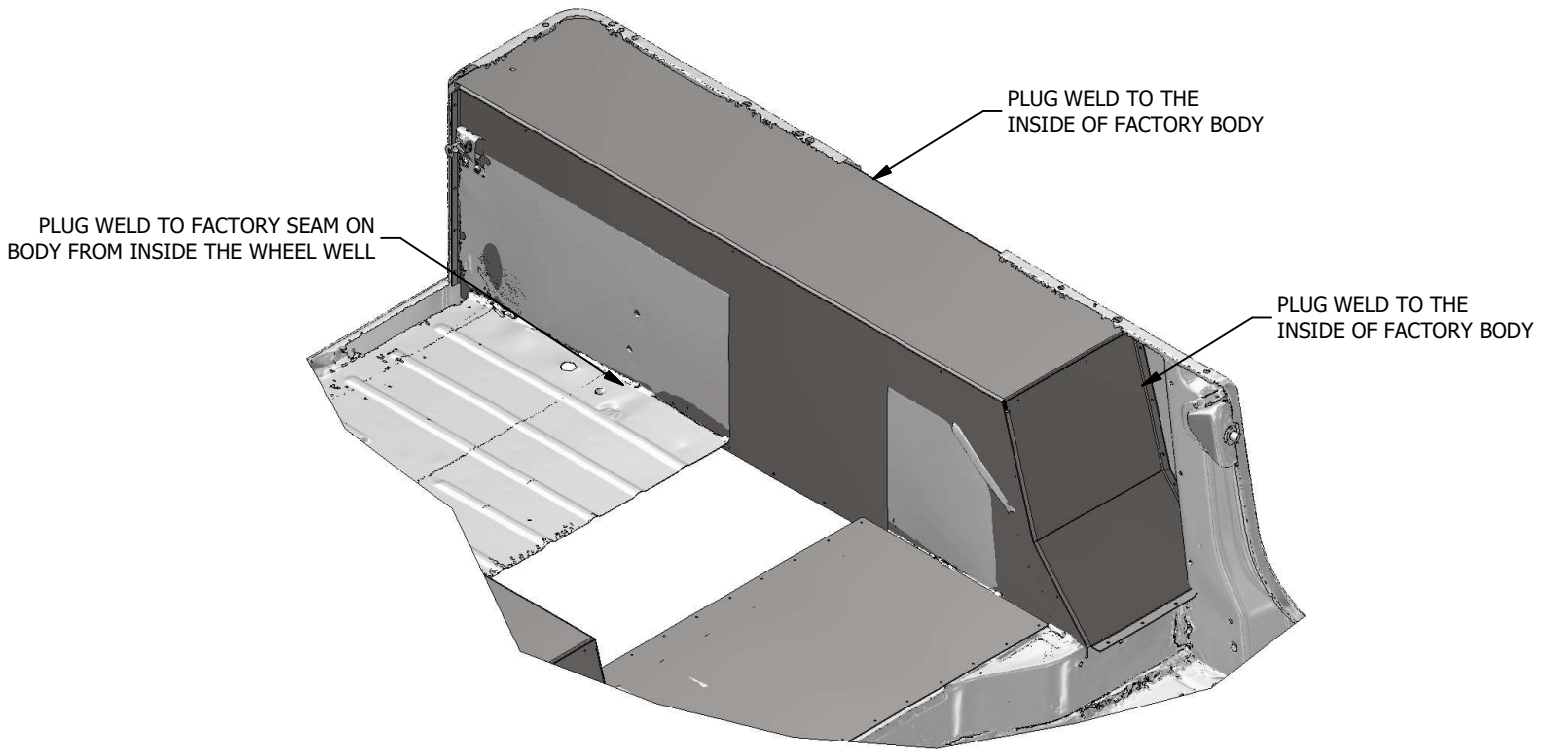

MB5529 - Assembly Instructions YJ Rear Inner Fenders - Highline 15' Stretch

INNER FENDER ASSEMBLY

