

# MB5521 ROUND TAIL LIGHT CONVERSION KIT FOR JEEP JL W/O SENSORS

DRIVERS SIDE

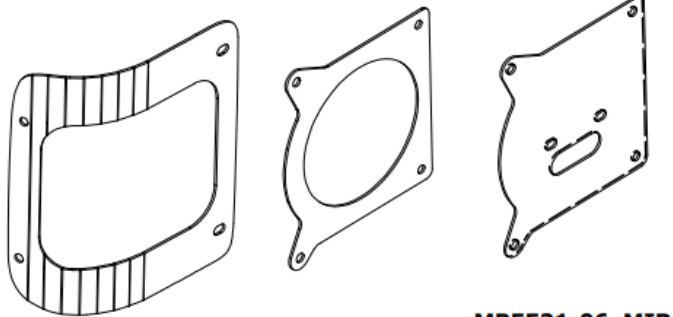

**MB5521-01\_MIR**  
Qty 1

**MB5521-03\_MIR**  
Qty 1

**MB5521-06\_MIR**  
Qty 1

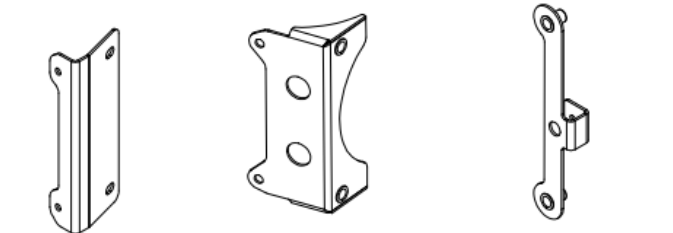

**MB5521-02\_MIR**  
Qty 1

**MB5521-04\_MIR**  
Qty 1

**MB5521-05\_MIR**  
Qty 1

PASSENGER SIDE

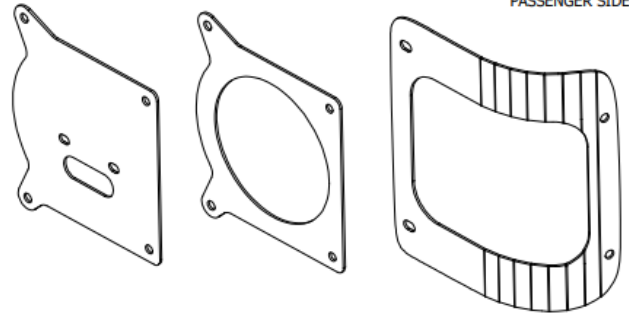

**MB5521-06**  
Qty 1

**MB5521-03**  
Qty 1

**MB5521-01**  
Qty 1

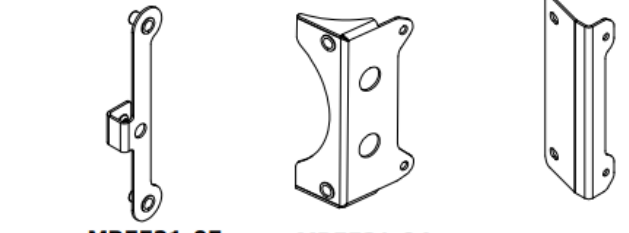

**MB5521-05**  
Qty 1

**MB5521-04**  
Qty 1

**MB5521-02**  
Qty 1

FASTENERS



**HEX BUTTON HEAD SCREW**  
#10-24 x 1/2" S.S.  
Qty 6



**NYLOCK NUT**  
#10-24 S.S.  
Qty 6

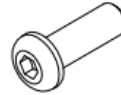

**HEX BUTTON HEAD SCREW**  
1/4"-20 x 3/4" S.S.  
Qty 12



**NYLOCK NUT**  
1/4"-20 S.S.  
Qty 4

**MB5521 ROUND TAIL LIGHT CONVERSION KIT FOR JEEP JL W/O SENSORS**

- 1** We recommend you install Motobilt parts raw steel, remove them once fitted, then paint or powder coat to avoid scratches.
- 2** If your Jeep came with incandescent bulb taillights, a resistor will be required for the new LED light to function properly. The taillight resistor can be purchased from the Motobilt website. Part# MB5519.
- 3** From the interior of the vehicle, remove the factory taillight assembly by first removing the interior trim panel cap. With the torx drive supplied from Jeep, remove the plastic retaining screw.



- 4** Remove the taillight assembly from the vehicle and disconnect the electrical harness



**MB5521 ROUND TAIL LIGHT CONVERSION KIT FOR JEEP JL W/O SENSORS**

**5** With the factory taillight removed install MB5521-02 by aligning the edge of the plate with the factory pinch weld and mark the two hole centers.

**6** Center punch and drill the factory pinch weld using a 3/16" drill bit.



**7** With a 3/8" open ended wrench and 1/8" allen wrench, install MB5521-02 using two #10-24 hex button head screws and nylock nuts.



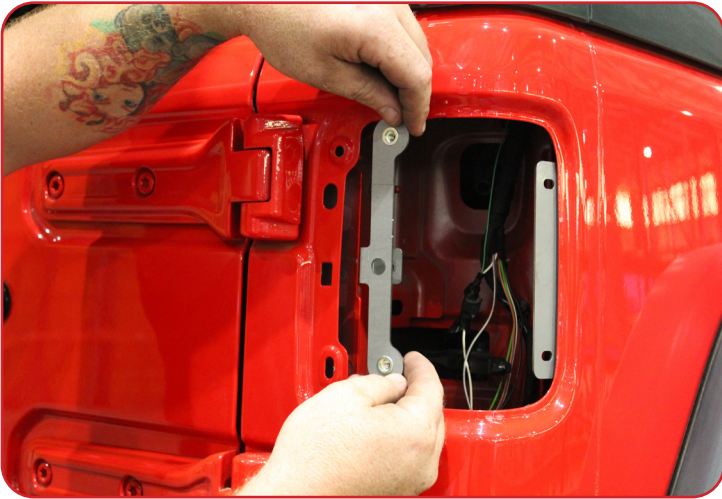

**MB5521 ROUND TAIL LIGHT CONVERSION KIT FOR JEEP JL W/O SENSORS**

- 8** On the passenger side, secure part MB5521-05 through the factory holes into the nutserts with (2) ¼"-20 hex button head screws.



- 9** Using the MB5521-05 as a guide, drill the center hole through the factory pinch weld using a 7/32" drill bit.

- 10** Secure MB5521-05 to the factory pinch weld with (1) #10-24 hex button head screw and nylock nut through the center hole. Now remove the (2) ¼"-20 hex button head screws installed earlier.



**MB5521 ROUND TAIL LIGHT CONVERSION KIT FOR JEEP JL W/O SENSORS**

- 11** On the driver's side secure MB5521-05\_MIR in place with tape to align the nutserts with the top and bottom holes.

- 12** The next [three] steps will align the parts to the Jeep body. The hardware should be snugged down to allow for some movement, but not fully tightened.

- 13** Install MB5521-01 and MB5521-04 simultaneously using (2) 1/4"-20 hex button head screws and nylock nuts. Fasten MB5521-01 and MB5521-04 to MB5521-02 through the slotted holes with a 5/32" allen wrench and 7/16" open ended wrench. Do not tighten fully yet.





**MB5521 ROUND TAIL LIGHT CONVERSION KIT FOR JEEP JL W/O SENSORS**

**14** Install MB5521-03 to MB5521-04 and MB5521-05 with (4) 1/4"-20 hex button head screws. With all the parts aligned, use the center hole of MB5521-03 for access, and tighten the (2) 1/4"-20 hex button head screws from step 4 that fasten MB5521-01 and MB5521-04 to MB5521-02.

**15** With all the parts aligned, use the center hole of MB5521-03 for access, and tighten the (2) 1/4"-20 hex button head screws from step 4 that fasten MB5521-01 and MB5521-04 to MB5521-02.

**16** All fasteners should now be fully tightened.

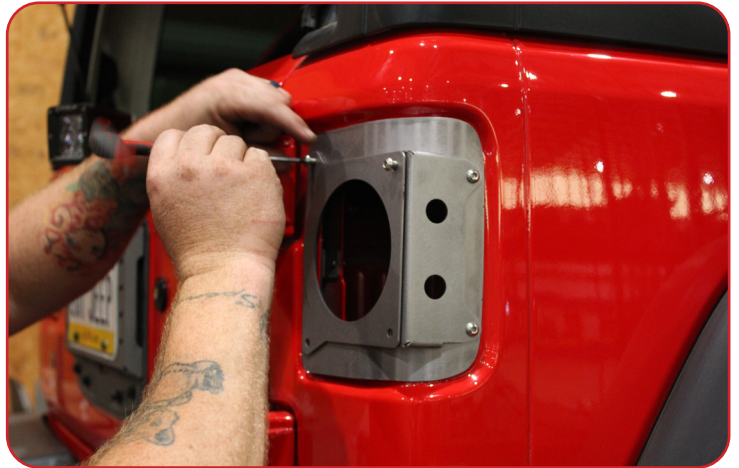

**17** Install 3/4" side marker lights MB5521-04. There are several options available on [Motobilt.com](http://Motobilt.com)

**MB6501****MB6500****MB6503**

## MB5521 ROUND TAIL LIGHT CONVERSION KIT FOR JEEP JL W/O SENSORS

18

MB5521-03 can now be removed to install MB5521-06 depending on the type of taillight desired. MB5521-03 is designed to be used with 4" round LED taillights.



**MB6502**



**MB5521-03**



**MB5521-06**