

MB5066 - Assembly Instructions JL 392 Washer Fluid Tank

**This product fits Jeep
JL/JLU with the 392 Engine**

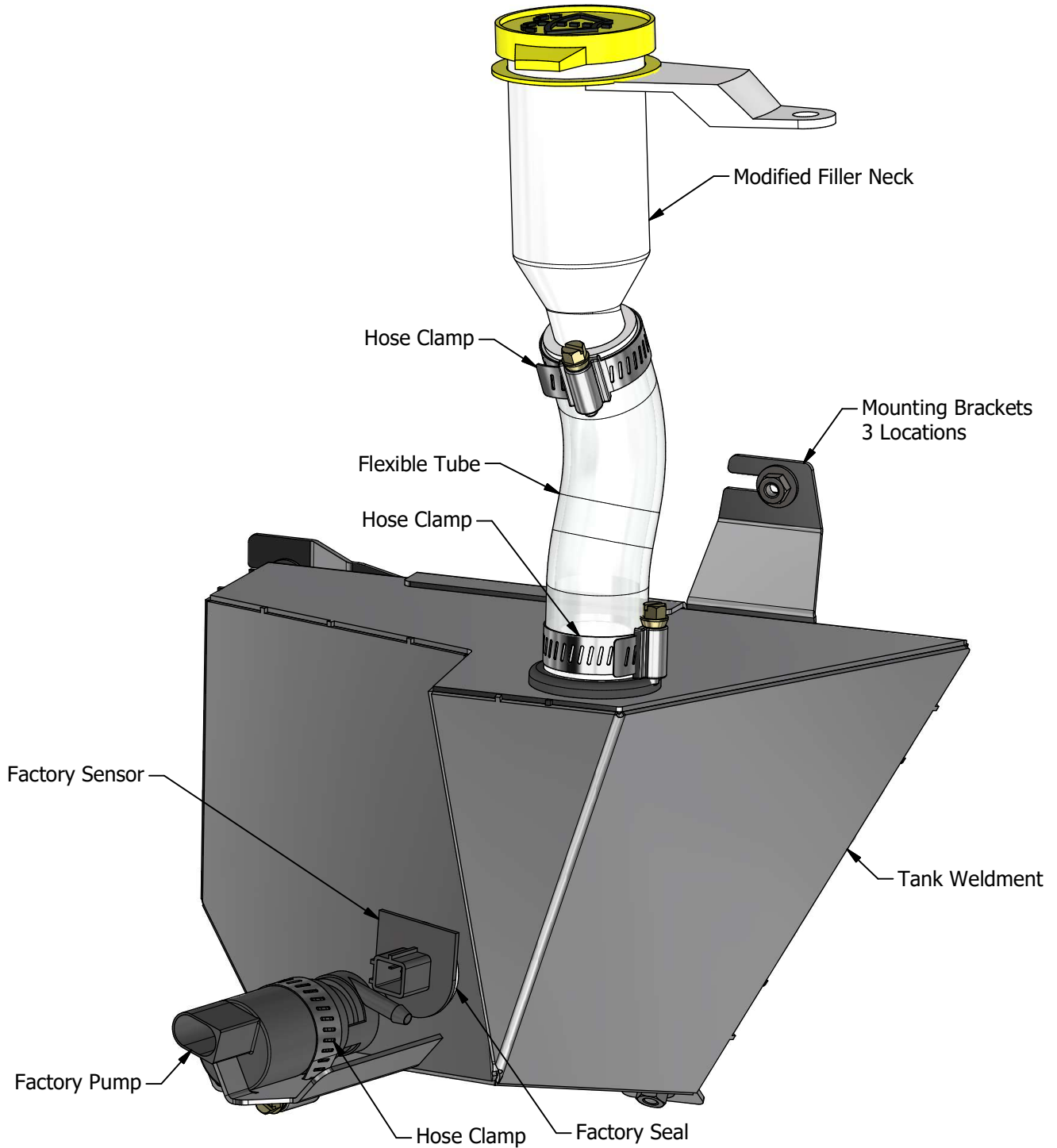

MB5066 - Assembly Instructions JL 392 Washer Fluid Tank

CONTENTS

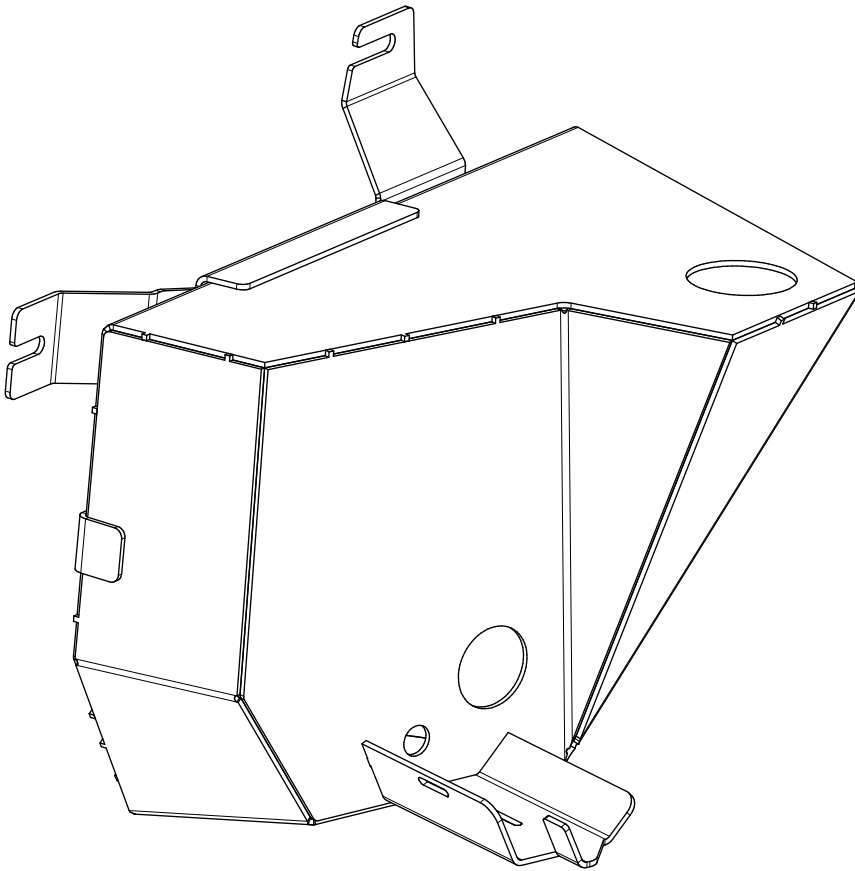

**MB5066 - Tank Weldment
Qty 1**

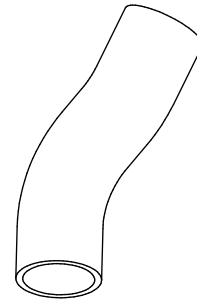

**Hose, 5-1/2" Long
Qty 1**

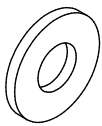

**Flat Washer, 1/4"
Qty 3**

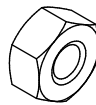

**Nylock Nut, M6 x 1.0
Qty 3**

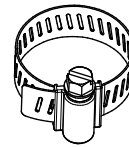

**Hose Clamp, 1.50" Dia
Qty 3**

MB5066 - Assembly Instructions JL 392 Washer Fluid Tank

Remove the factory windshield washer fluid tank from the vehicle



Using a 10mm socket, remove the bolt holding the Filler Neck to the fender structure. The factory filler neck is pushed into the factory windshield washer fluid tank. There is a rubber seal that connect the two parts. Once the bolt is removed, simply lift up on the filler neck to pull it away from the rubber seal in the tank.

Using a 10mm socket, remove the upper bolt holding the windshield washer fluid tank to the fender structure. The other points holding the tank are friction fit, thus, pull forward to release the tank from the friction fittings.

Disconnect the wiring to the sensor & the pump.

Disconnect the Pump Outlet Hose from the pump.

MB5066 - Assembly Instructions JL 392 Washer Fluid Tank

Remove the factory windshield washer fluid pump & strainer/seal



Factory Windshield Washer Fluid Tank - Diesel Gladiator

Pump

Pump Outlet

Pump Strainer & Seal

MB5066 - Assembly Instructions JL 392 Washer Fluid Tank

Remove the factory low fluid sensor & seal

Low Fluid Sensor

Seal for Low Fluid Sensor



MB5066 - Assembly Instructions JL 392 Washer Fluid Tank



Seal for Filler Neck

Remove the factory seal for the filler neck

MB5066 - Assembly Instructions JL 392 Washer Fluid Tank

Modify the factory filler neck

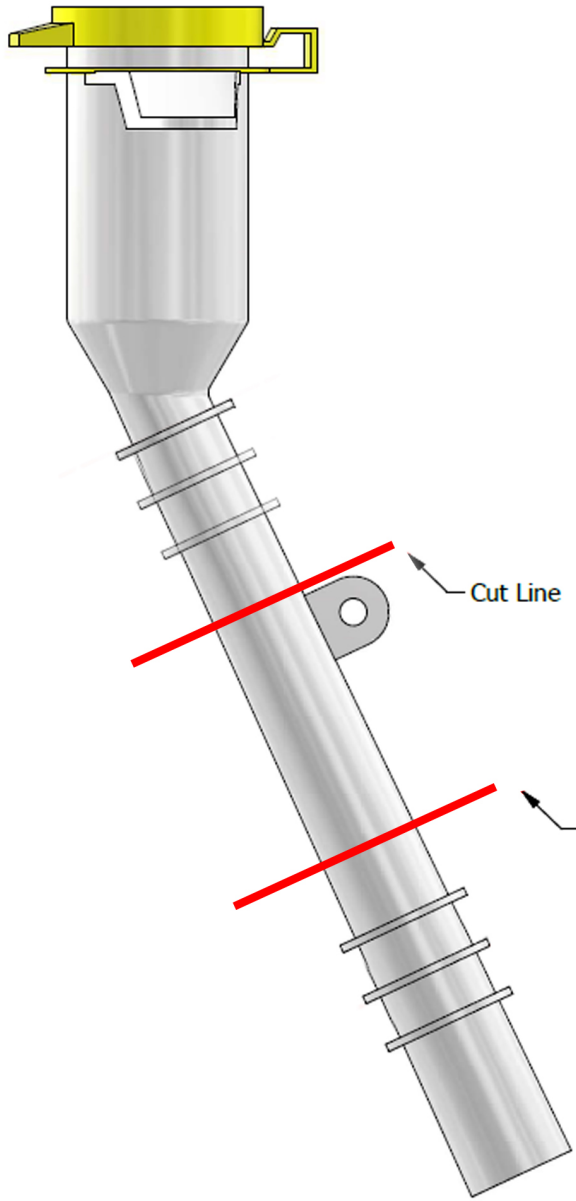

**Filler Neck
Before Modification**

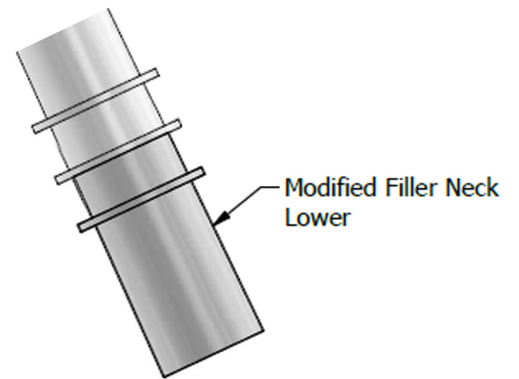
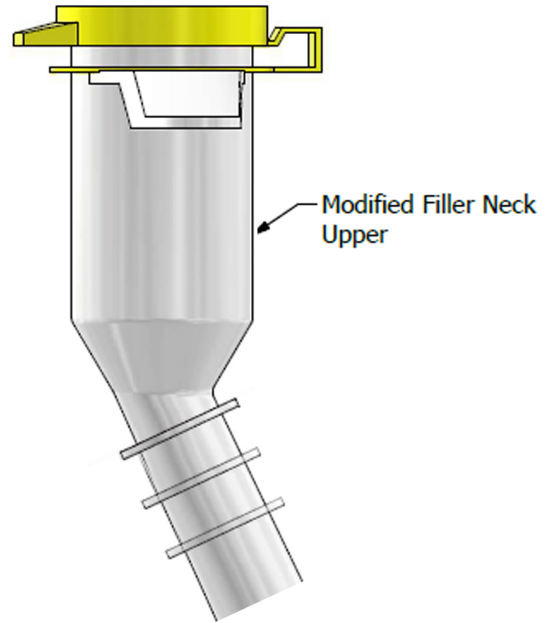

**Filler Neck
After Cutting**

MB5066 - Assembly Instructions JL 392 Washer Fluid Tank

Assemble the filler neck

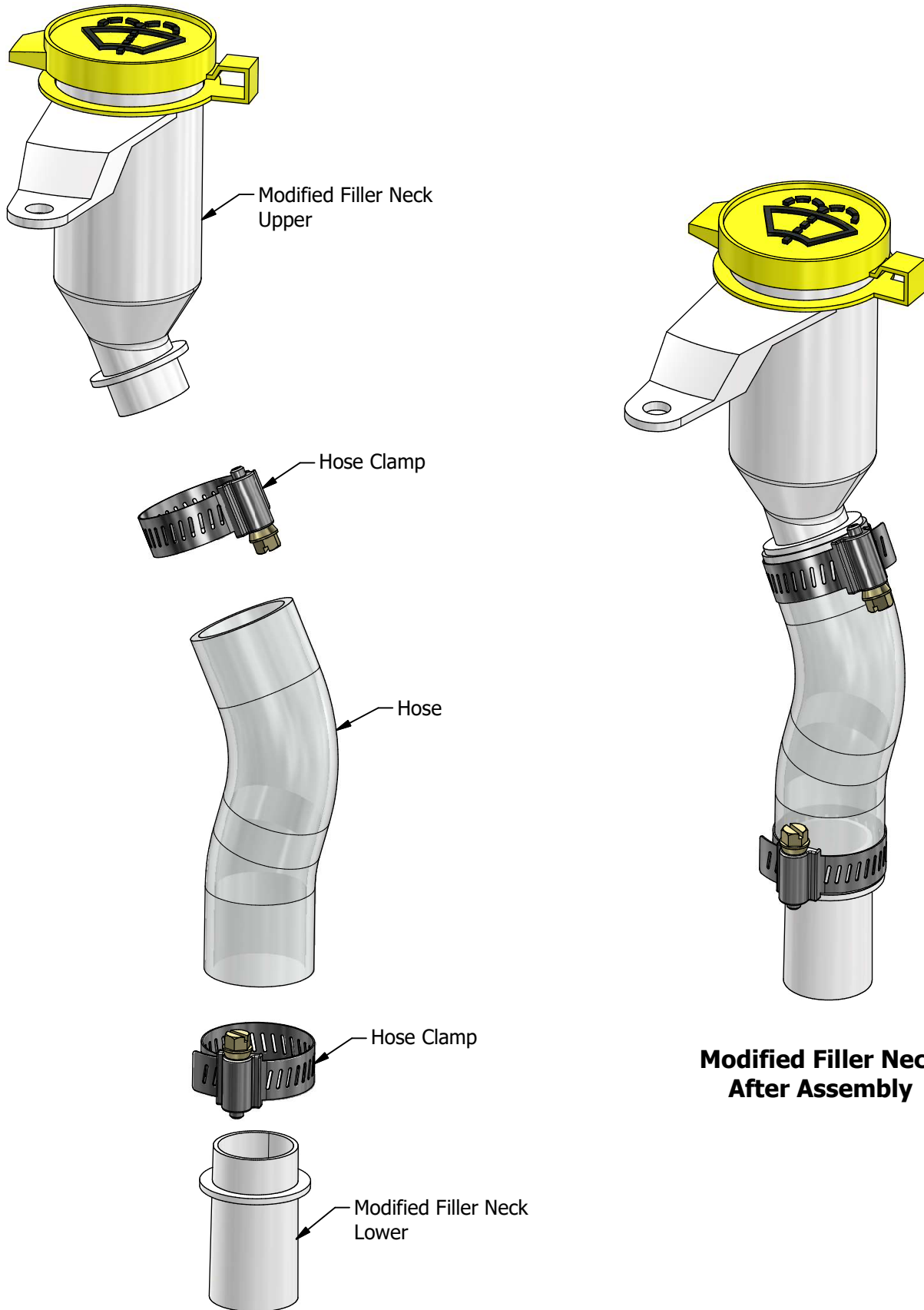

MB5066 - Assembly Instructions JL 392 Washer Fluid Tank

Assemble the washer fluid tank

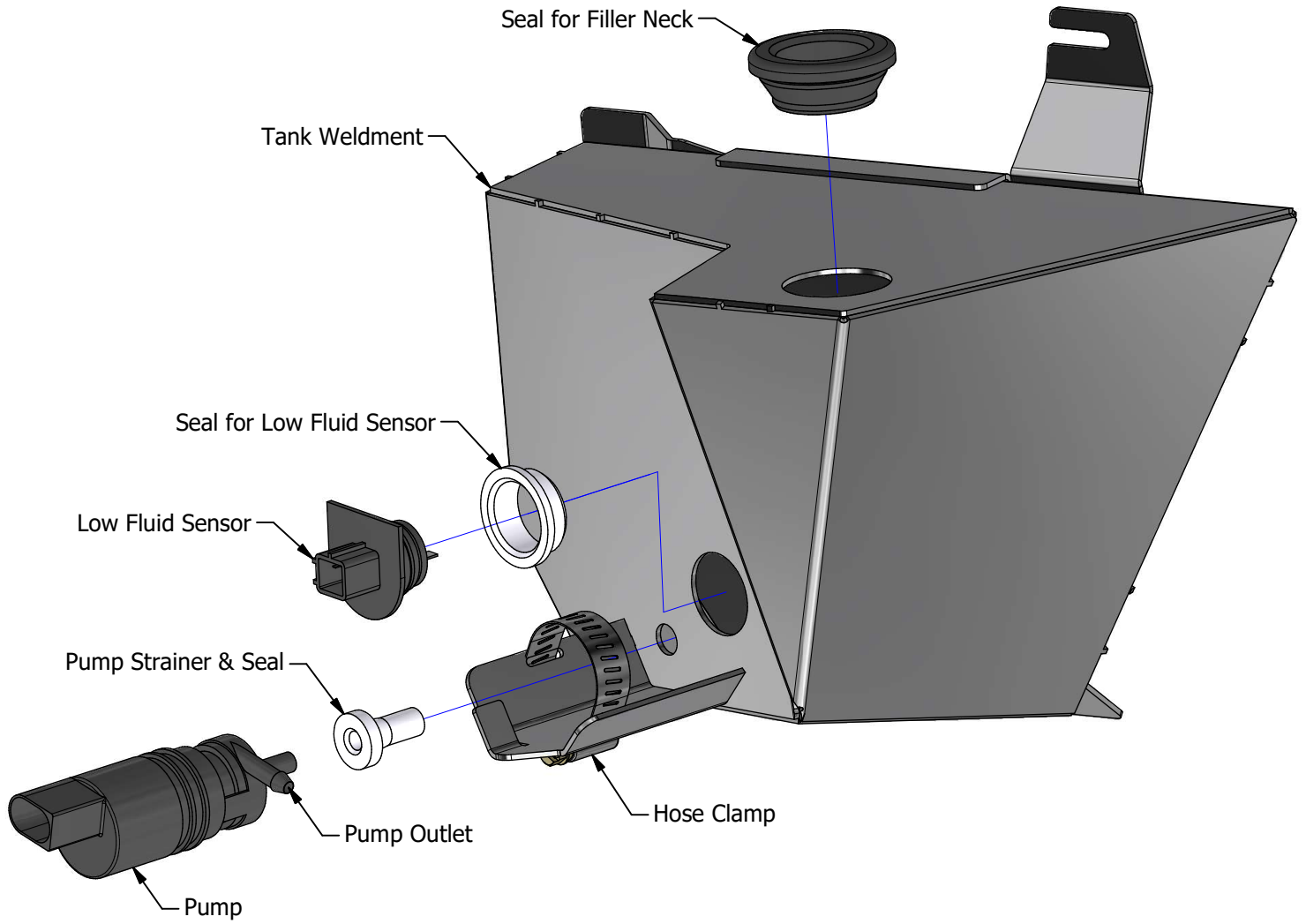

MB5066 - Assembly Instructions JL 392 Washer Fluid Tank

Install the washer fluid tank

Check for leaks around the pump and sensor seals by filling the tank BEFORE installing in the vehicle. If a leak is detected, a small amount of RTV sealant can be added around each seal.

Place the new washer fluid tank into position. On the Jeep JL/JLU with 392 Engine, there are three (3) existing studs on the firewall. Position the assembled tank on the three (3) studs. Use the included flat washers & nylock nuts to fasten the tank to the firewall. Connect the filler assembly. Connect the factory wiring. Connect the washer fluid hose.

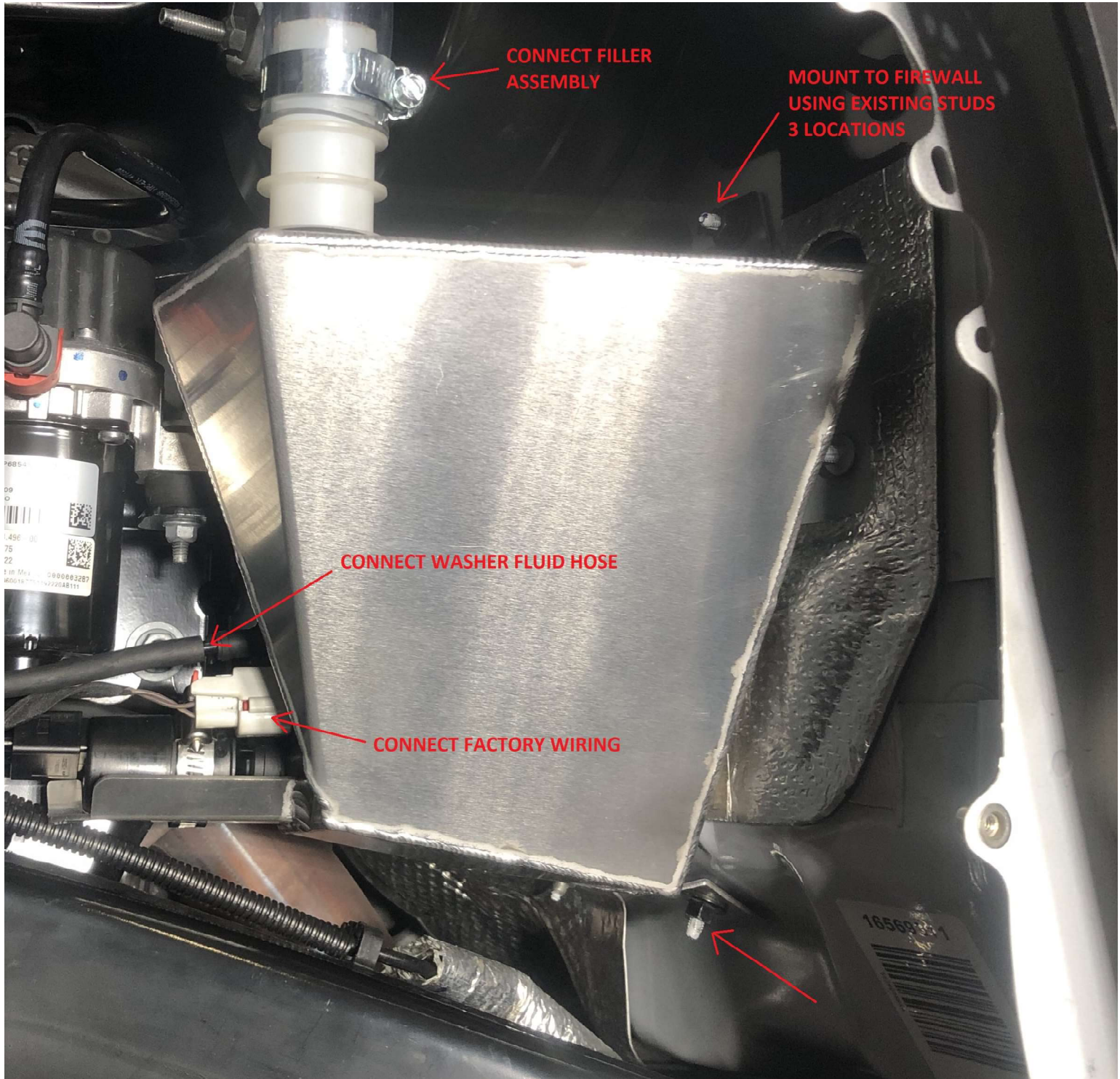

MB5066 - Assembly Instructions JL 392 Washer Fluid Tank**Install the modified filler neck**

Place the modified filler neck down through the engine bay in its original position. Ensure the lower portion of the filler neck is firmly placed into the upper tank seal. Reuse the factory bolt to fasten the upper portion of the filler neck to the fender. Connect the factory hose to the factory pump. Connect the factory wiring to the pump & sensor. Fill the tank with fluid. Check for leaks.



MB5066 - Assembly Instructions JL 392 Washer Fluid Tank

