

# **MB4082 - SUPER DUTY 60 HIGH STEER BRACKETS**

**COMPATIBLE WITH 2005-2008 & 2009-2012**



**MB4082 - Assembly Instructions Ford Super Duty 2009+ High Steer Brackets**

# CONTENTS

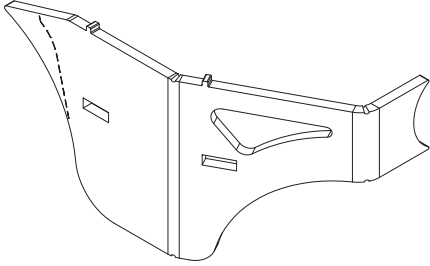
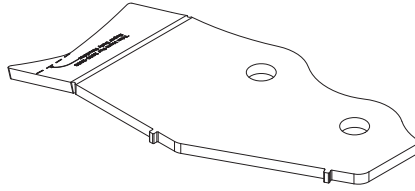
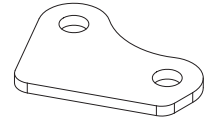
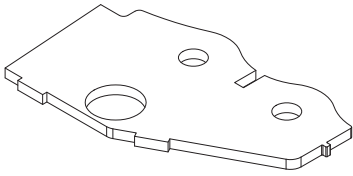
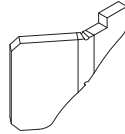
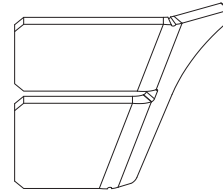
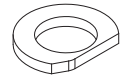
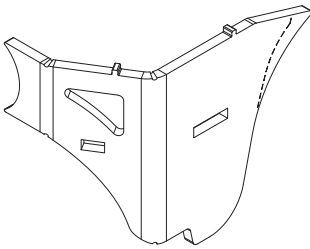
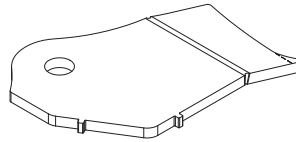
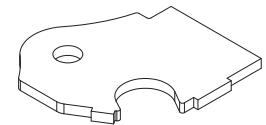
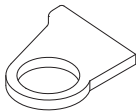
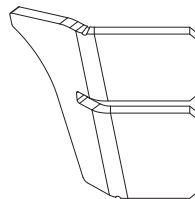
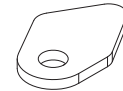
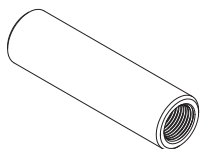
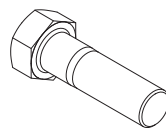
**MB4082-02  
QTY 1****MB4082-03  
QTY 1****MB4082-04  
QTY 1****MB4082-05  
QTY 1****MB4082-06  
QTY 1****MB4082-07  
QTY 1****MB4082-08  
QTY 1****MB4082-09  
QTY 1****MB4082-10  
QTY 1****MB4082-11  
QTY 1****MB4082-12  
QTY 1****MB4082-13  
QTY 1****MB4082-14  
QTY 1****MB4082-01  
QTY 2****HEX BOLT, 7/8"-14 UNF X 3.0"  
QTY 2****FLAT WASHER, 7/8"  
QTY 2**

**Knuckle Identification 2005-2012 Knuckle Differences****HOW TO IDENTIFY YOUR KNUCKLES**

Before you start, you need to ensure you have identified which steering knuckles you have.

Our assembly instructions show step-by-step instructions based on either 2009-2012 knuckles or 2005-2008 knuckles. Please identify your knuckles & read the appropriate assembly directions based on the model year of steering knuckles you are using.

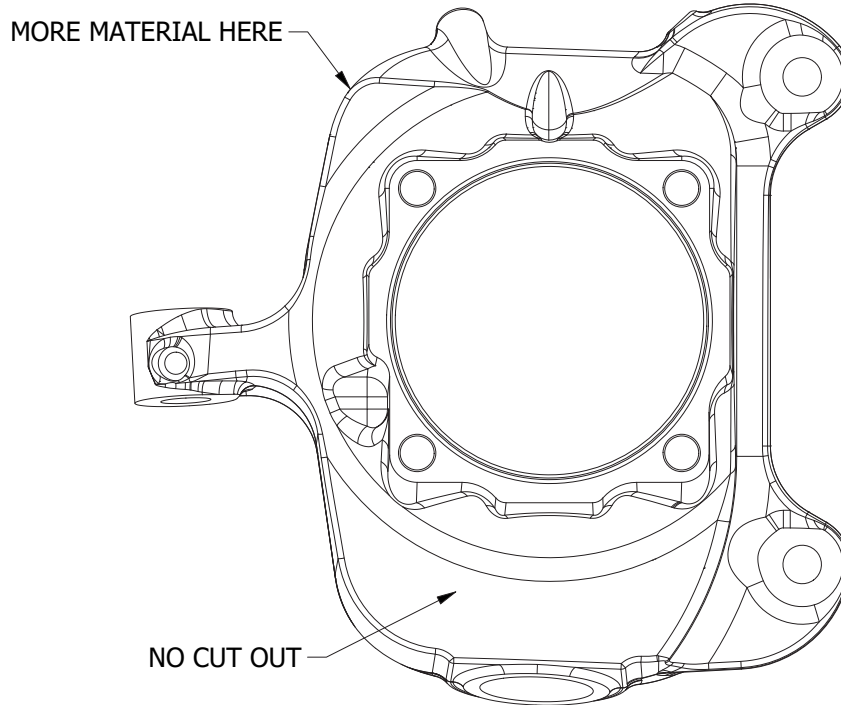

**2005-2008 Driver Side Knuckle  
(similar for Passenger Side knuckle)**

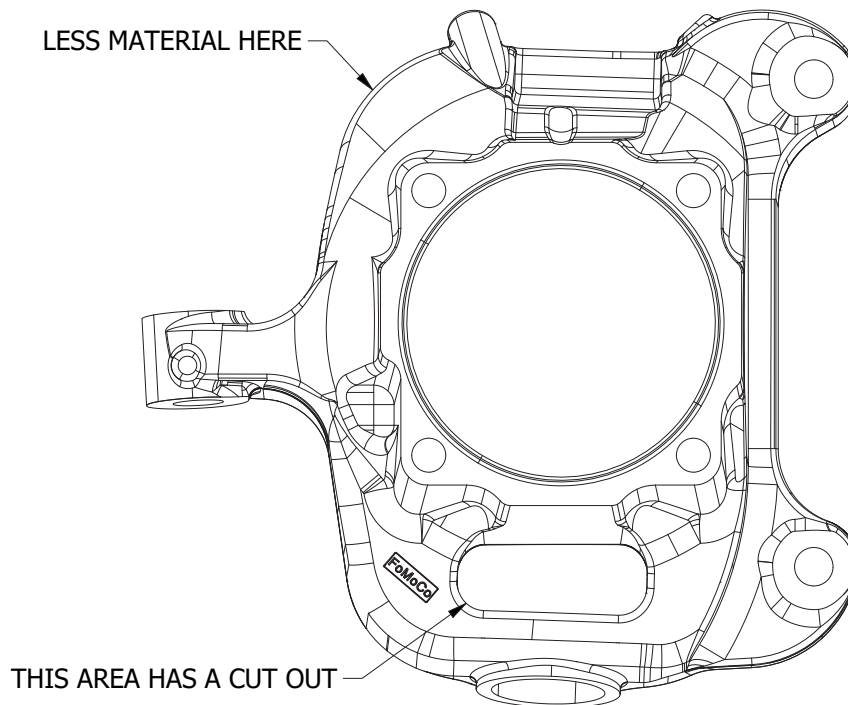

**2009-2012 Driver Side Knuckle  
(Similar for Passenger Side knuckle)**

**MB4082-03 Plate 03**

## SCRIBE LINES

Our MB4082 kit includes a series of laser cut & CNC formed plates that are designed to fit Ford F250 or F-350 Super Duty 60 front axle steering knuckles ranging from model years 2005 thru 2012.

Out of the box, this kit is designed to fit directly on 2009-2012 knuckles without modification or trimming.

To make this kit adapt to 2005-2008 knuckles, trimming of certain plates is required. We have laser etched scribe lines on certain parts, as shown below. The dashed line indicates where you must trim the part to allow it to fit a 2005-2008 knuckle.

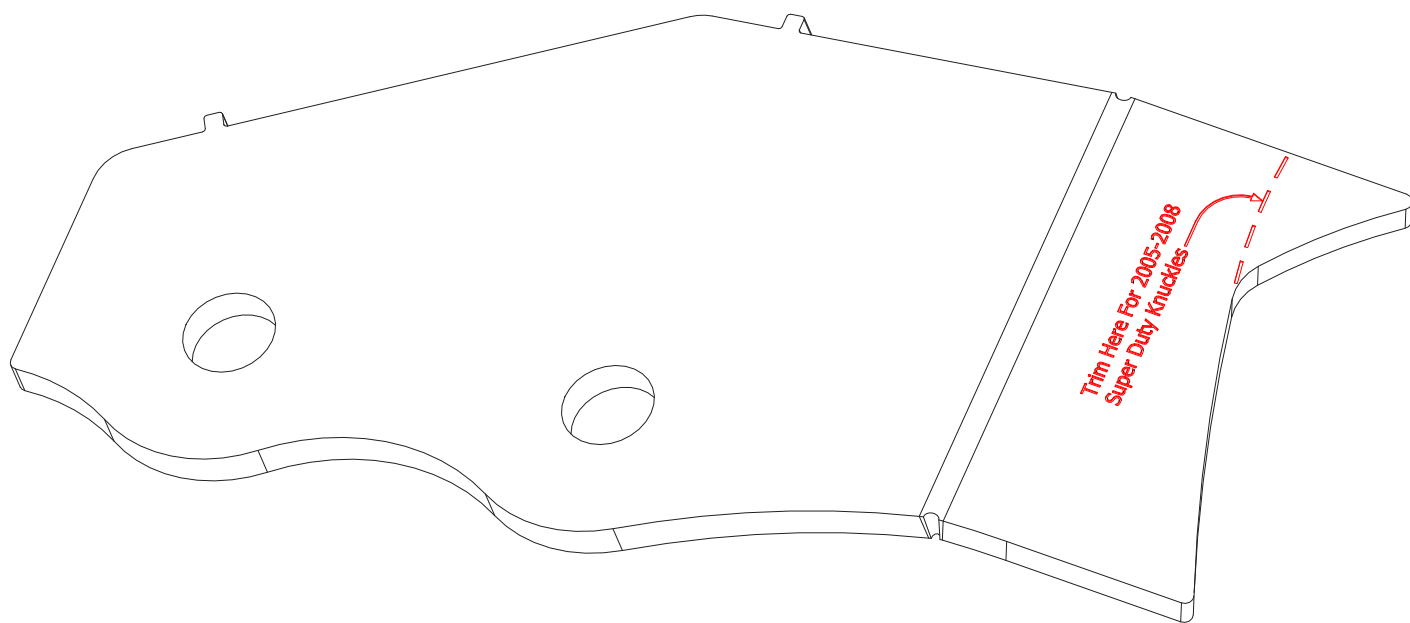

**MB4082 - Assembly Driver High Steer Brackets Super Duty 60**

**2009-2012 F-250 or F-350 Super Duty 60**

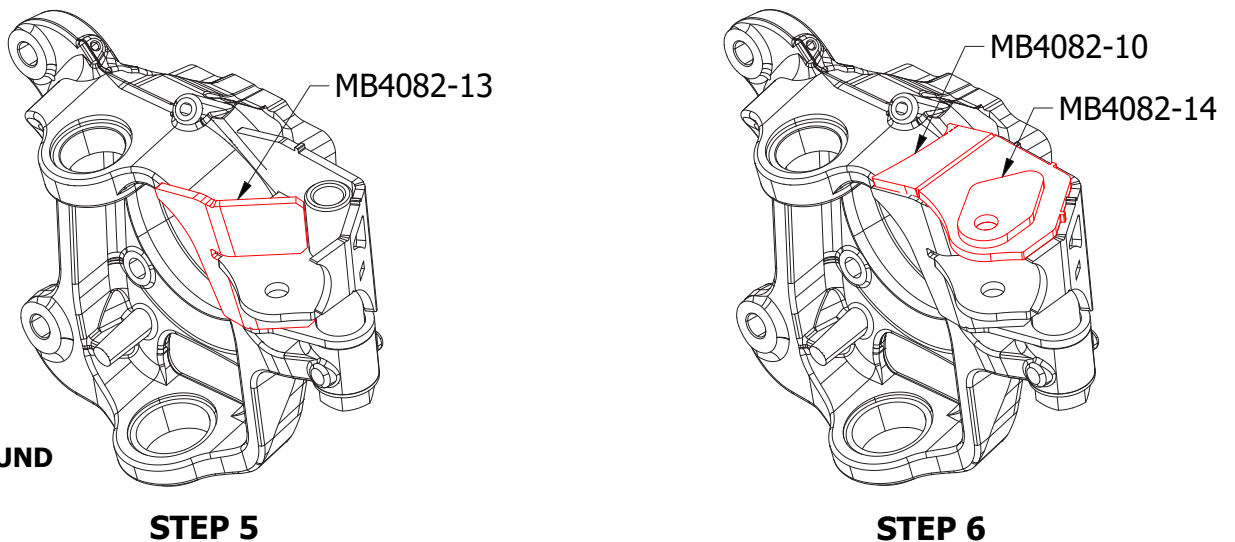
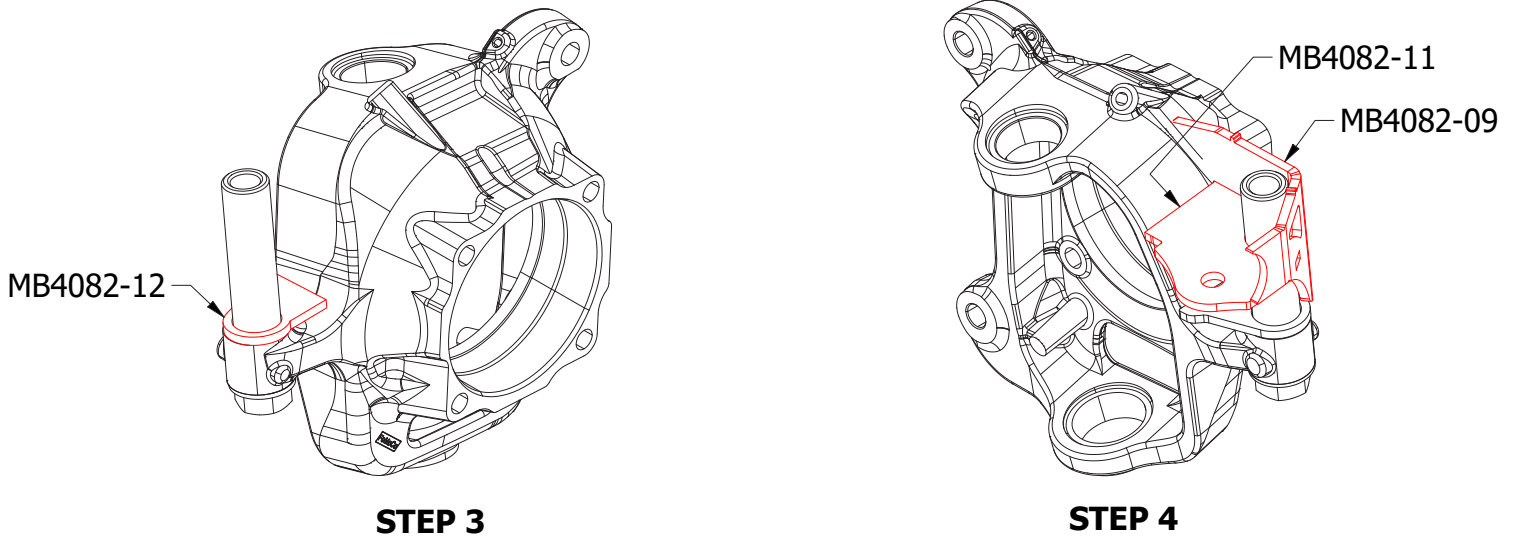
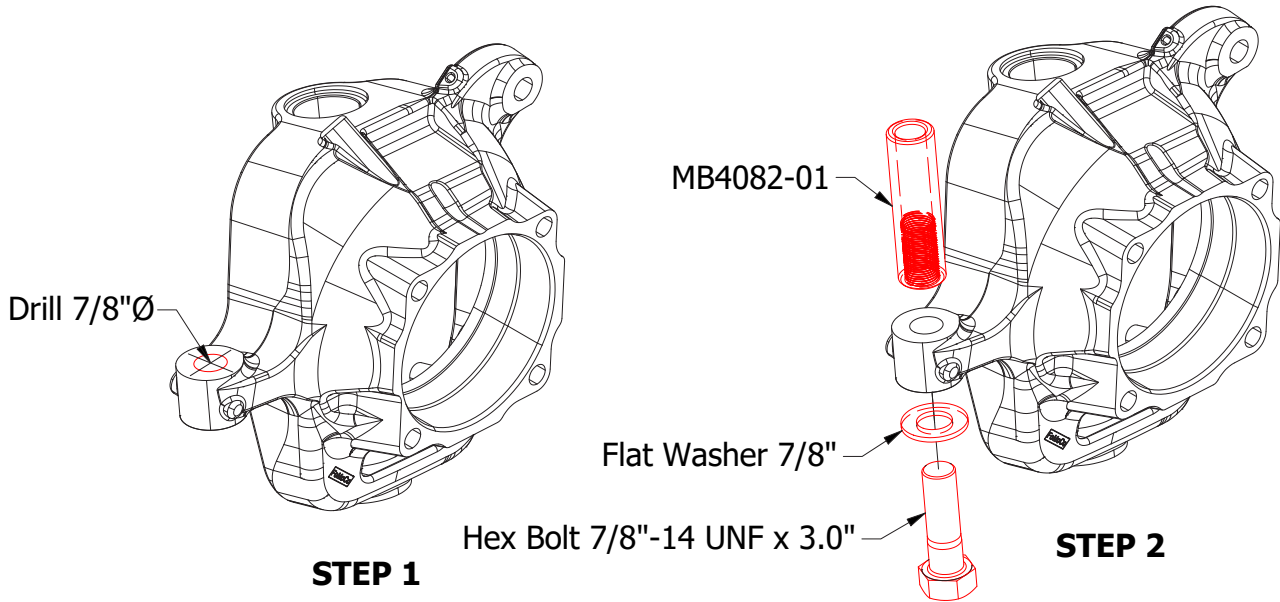

**FULLY WELD ALL AROUND  
AFTER ASSEMBLY**

**PAINT TO SUIT**

**MB4082 - Assembly Passenger High Steer Brackets Super Duty 60**

**2009-2012 F-250 or F-350 Super Duty 60**

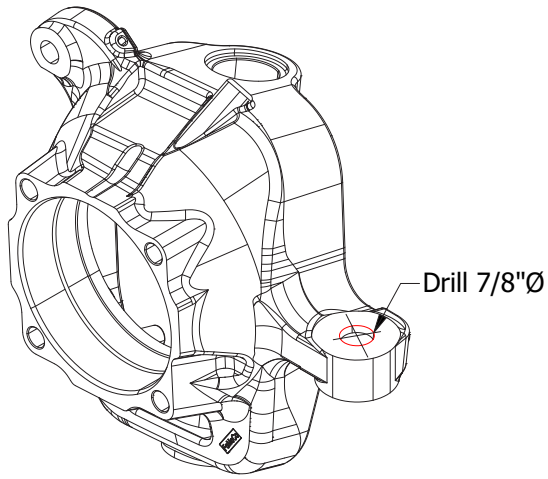

**STEP 1**

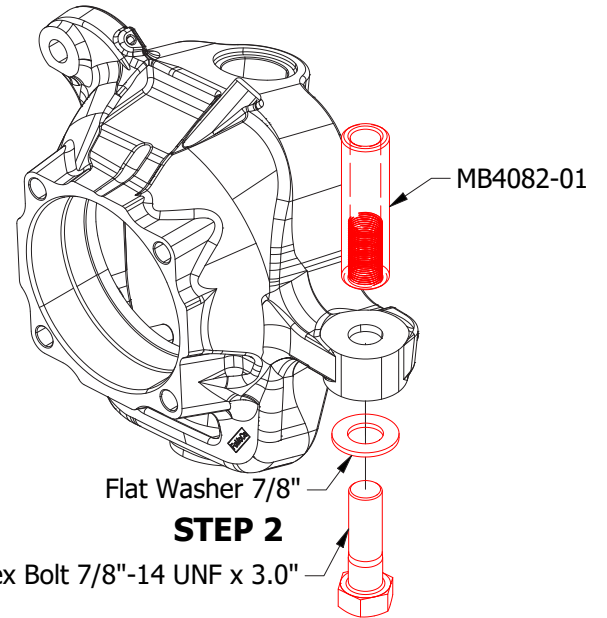

**STEP 2**

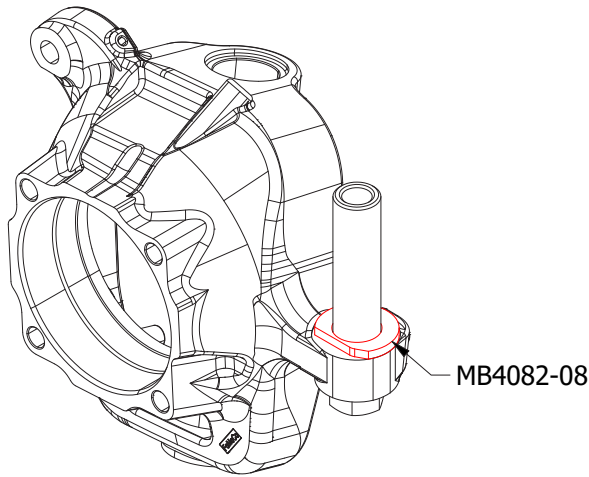

**STEP 3**

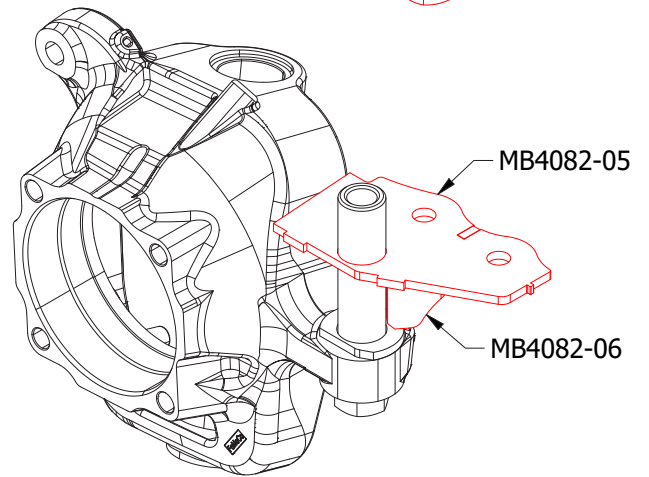

**STEP 4**

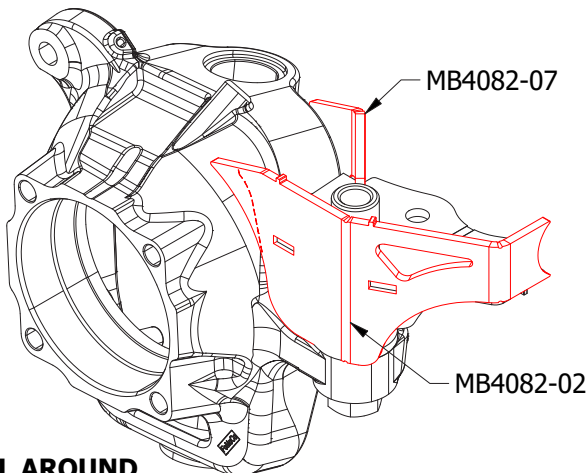

**STEP 5**

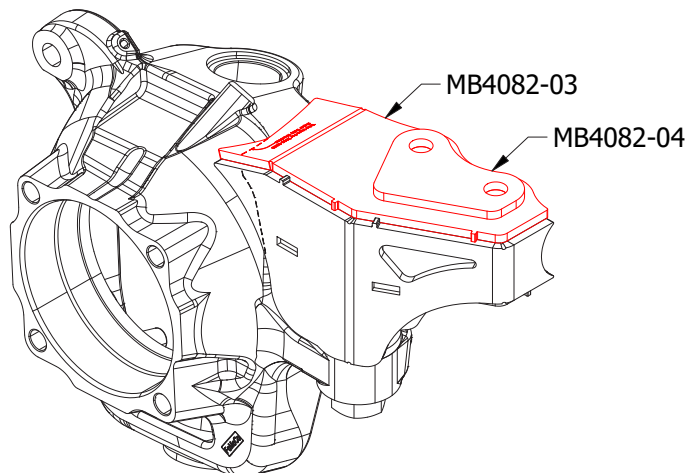

**STEP 6**

**FULLY WELD ALL AROUND  
AFTER ASSEMBLY**

**PAINT TO SUIT**

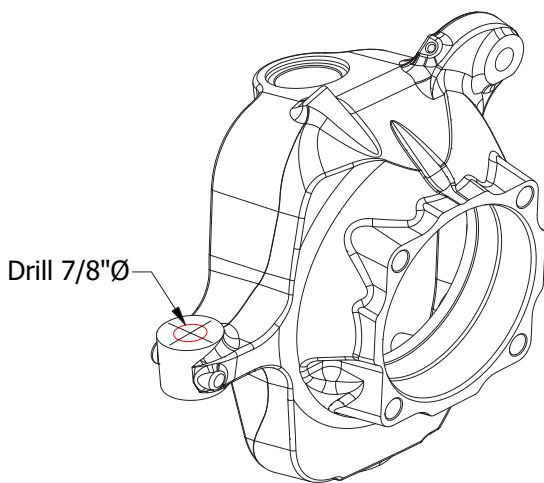
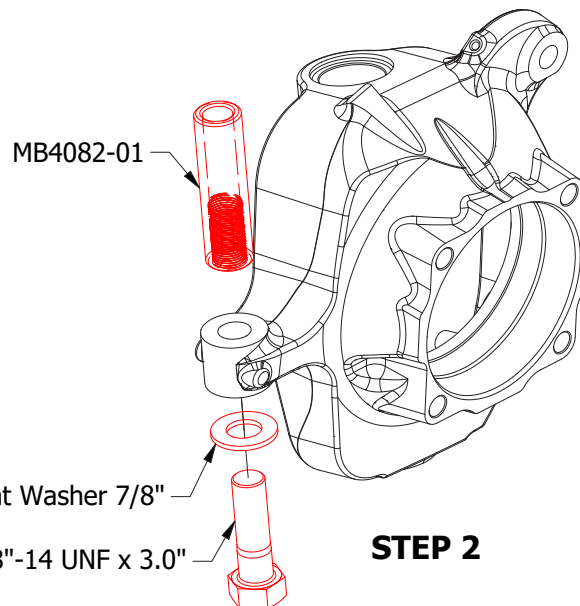
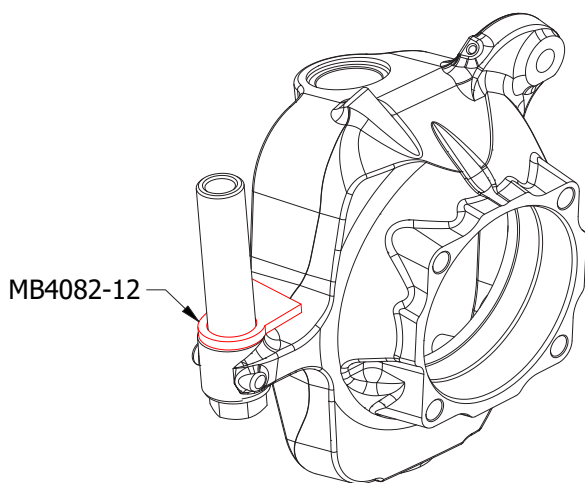
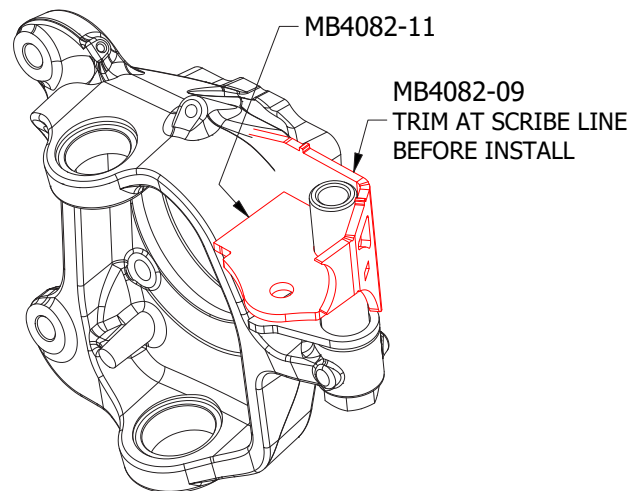
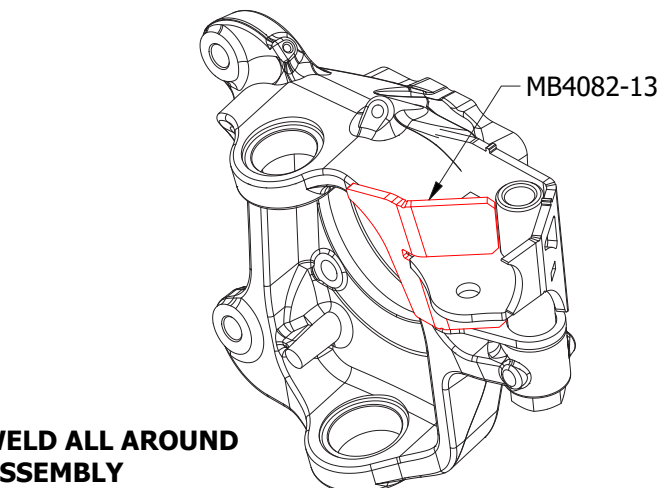
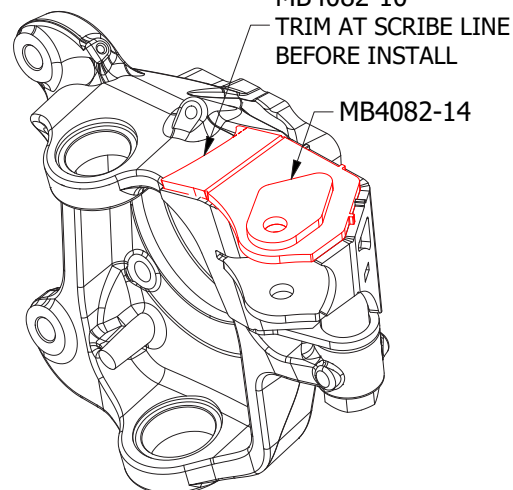
**MB4082 - Assembly Driver High Steer Brackets Super Duty 60****2005-2008 F-250 or F-350 Super Duty 60****STEP 1****STEP 2****STEP 3****STEP 4****STEP 5****STEP 6**

**FULLY WELD ALL AROUND  
AFTER ASSEMBLY**

**PAINT TO SUIT**

**MB4082 - Assembly Passenger High Steer Brackets Super Duty 60**

**2005-2008 F-250 or F-350 Super Duty 60**

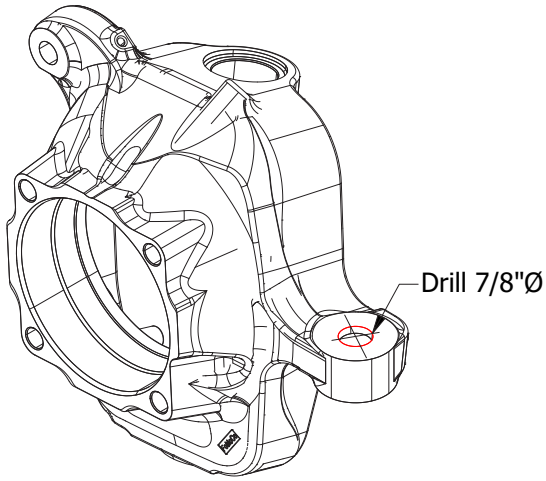

**STEP 1**

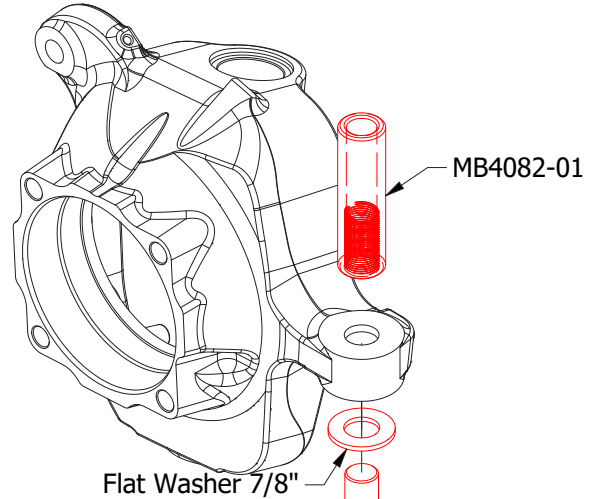

**STEP 2**

Hex Bolt 7/8"-14 UNF x 3.0"

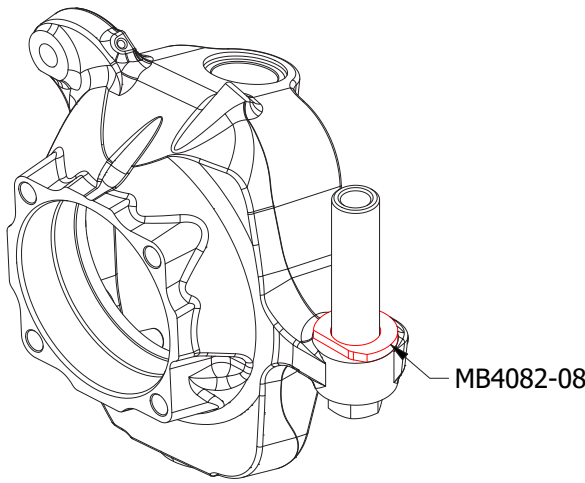

**STEP 3**

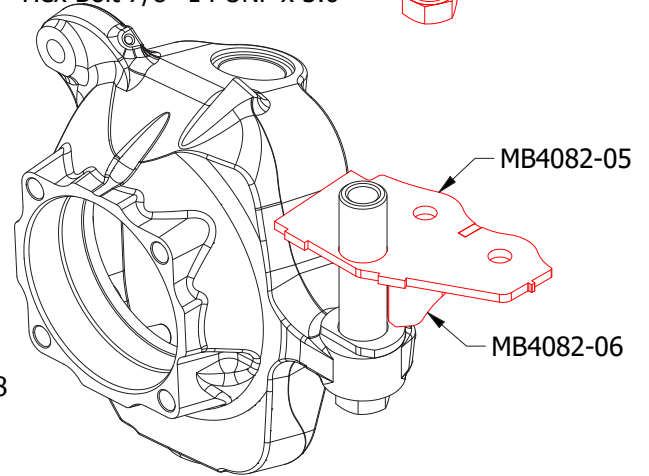

**STEP 4**

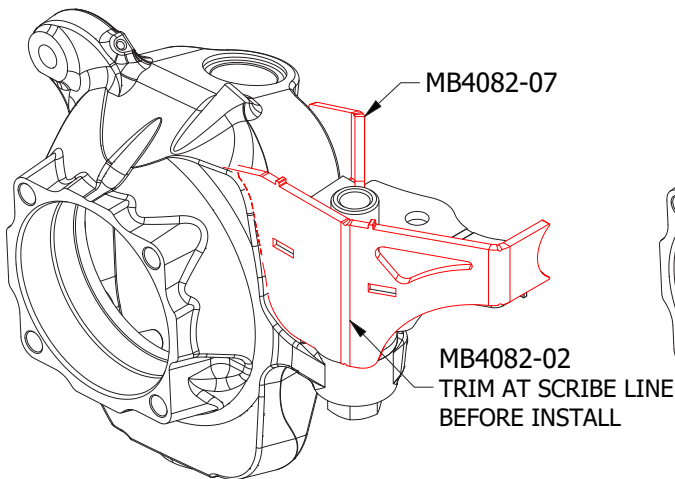

**STEP 5**

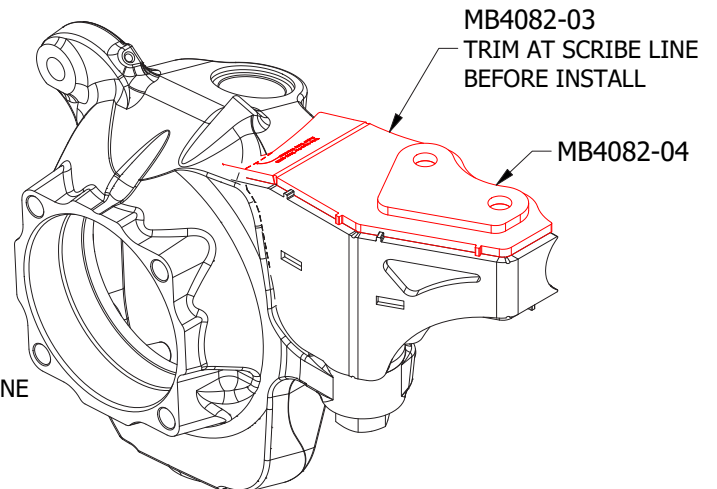

**STEP 6**

**FULLY WELD ALL AROUND  
AFTER ASSEMBLY**

**PAINT TO SUIT**