

# ASSEMBLY INSTRUCTIONS

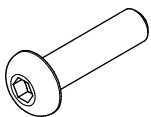

**MB3061 - Assembly Instructions Rear Soft Upper Window Adapter Kit JKU****CONTENTS**

**Button Head Screw  
#10-24 x 3/4"  
Qty 6**

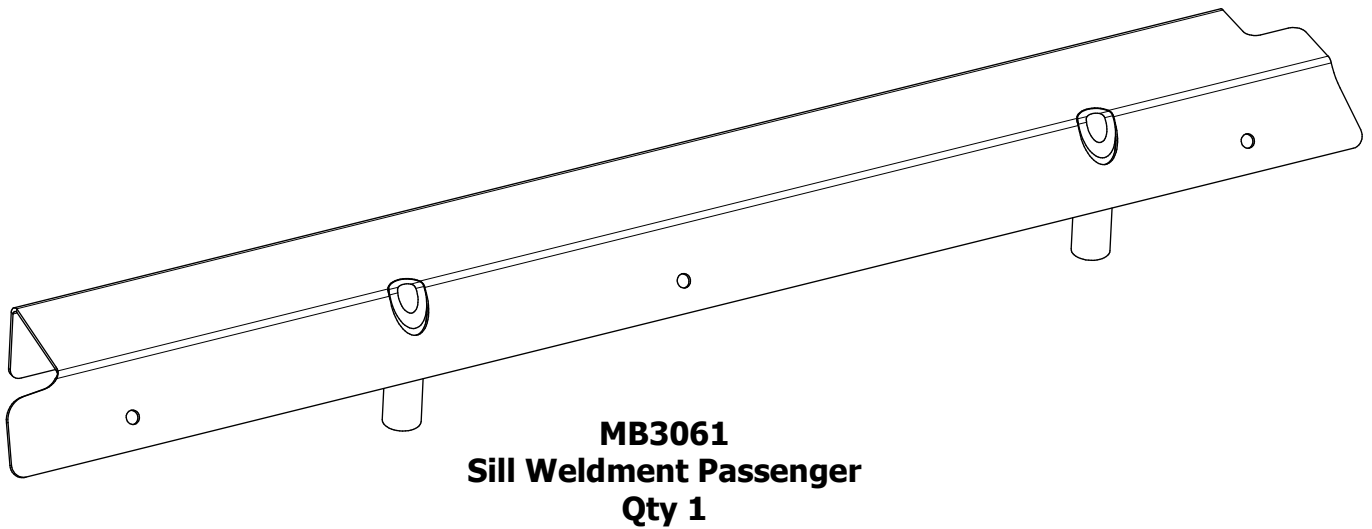
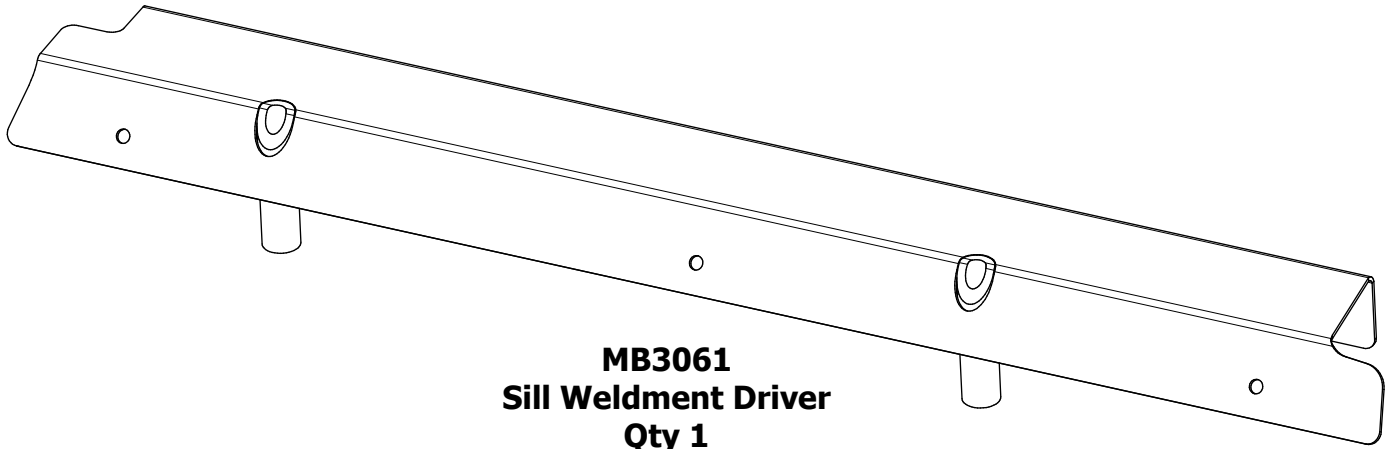

**Flat Washer  
M6  
Qty 6**



**Nylock Nut  
#10-24  
Qty 6**

**MB3061 - Assembly Instructions Rear Soft Upper Window Adapter Kit JKU****INSTRUCTIONAL VIDEO AVAILABLE**

[https://www.youtube.com/watch?v=qh\\_I0KH-hxs](https://www.youtube.com/watch?v=qh_I0KH-hxs)

Browse to YOUTUBE.com

Search "Front and Rear Soft Upper Kit for Motobilt Jeep JK/JKU Half Doors"

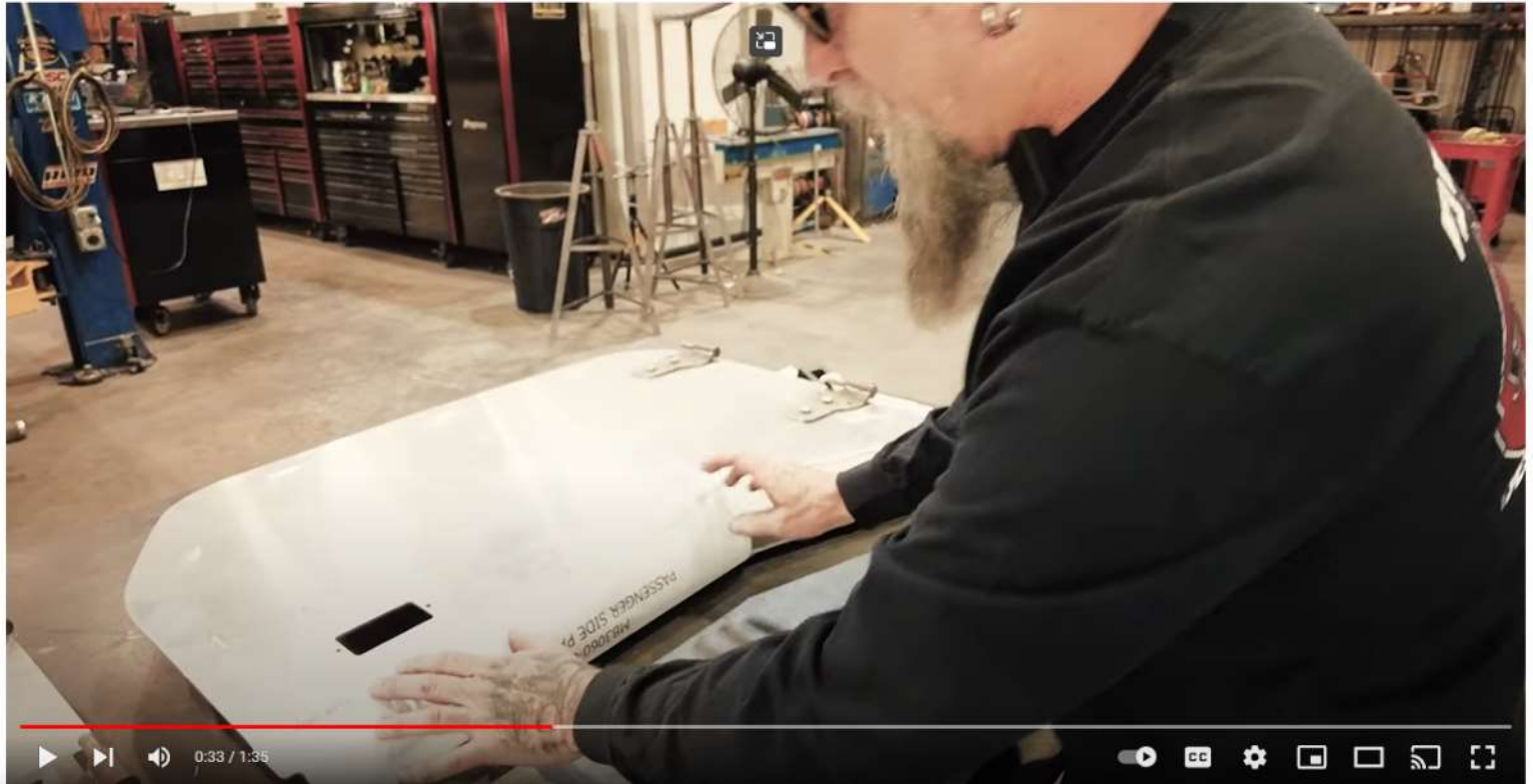

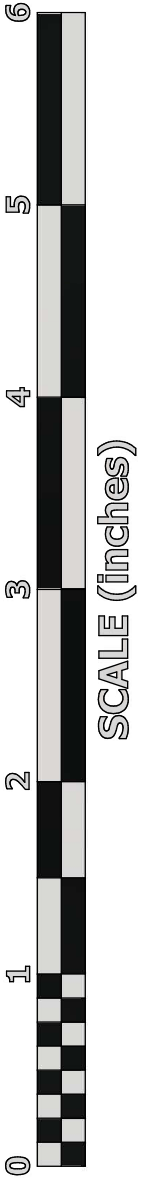

SCALE (inches)

FOLD

FOLD

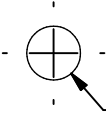

DO **NOT** MARK THIS HOLE USING THE PAPER TEMPLATE. THIS HOLE WILL BE MARKED WITH THE ACTUAL STEEL PARTS

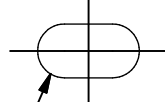

LINE UP WITH EXISTING HOLE ON INTERIOR DOOR SKIN

# MB3061-01 PAPER TEMPLATE "A" USED FOR MARKING LARGE CUTOUT

PRINT THIS SHEET ON  
8-1/2" x 11" PAPER AT  
100% SCALE

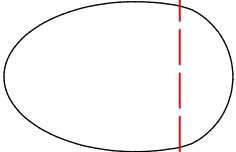

CUT OUT THIS HOLE ON PAPER TEMPLATE

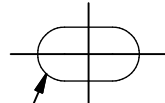

LINE UP WITH EXISTING HOLE ON INTERIOR DOOR SKIN



# MB3061-01 PAPER TEMPLATE "B" USED FOR MARKING LARGE CUTOUT

PRINT THIS SHEET ON  
8-1/2" x 11" PAPER AT  
100% SCALE

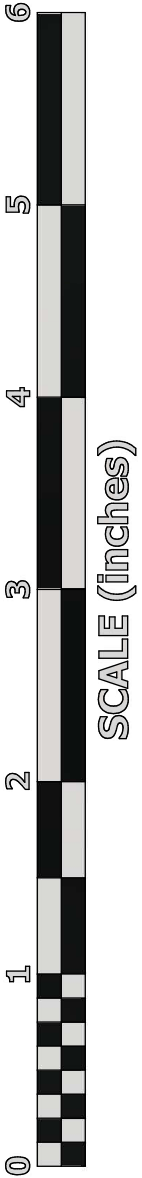

SCALE (inches)

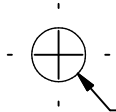

DO **NOT** MARK THIS HOLE  
USING THE PAPER TEMPLATE.  
THIS HOLE WILL BE MARKED  
WITH THE ACTUAL STEEL PARTS

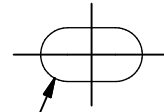

LINE UP WITH EXISTING  
HOLE ON INTERIOR  
DOOR SKIN

FOLD

FOLD

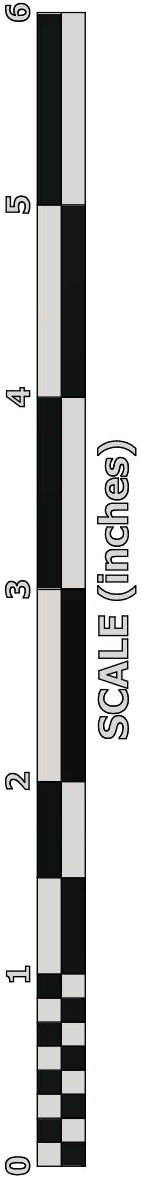

SCALE (inches)

# MB3061-01 PAPER TEMPLATE "C" USED FOR MARKING LARGE CUTOUT

PRINT THIS SHEET ON  
8-1/2" x 11" PAPER AT  
100% SCALE

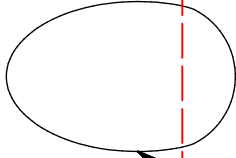

CUT OUT THIS HOLE  
ON PAPER TEMPLATE

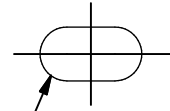

LINE UP WITH EXISTING  
HOLE ON INTERIOR  
DOOR SKIN

FOLD

FOLD

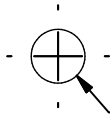

DO **NOT** MARK THIS HOLE  
USING THE PAPER TEMPLATE.  
THIS HOLE WILL BE MARKED  
WITH THE ACTUAL STEEL PARTS

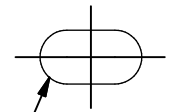

LINE UP WITH EXISTING  
HOLE ON INTERIOR  
DOOR SKIN

# JOIN TEMPLATES "A" + "B" + "C"

**NOT TO SCALE**

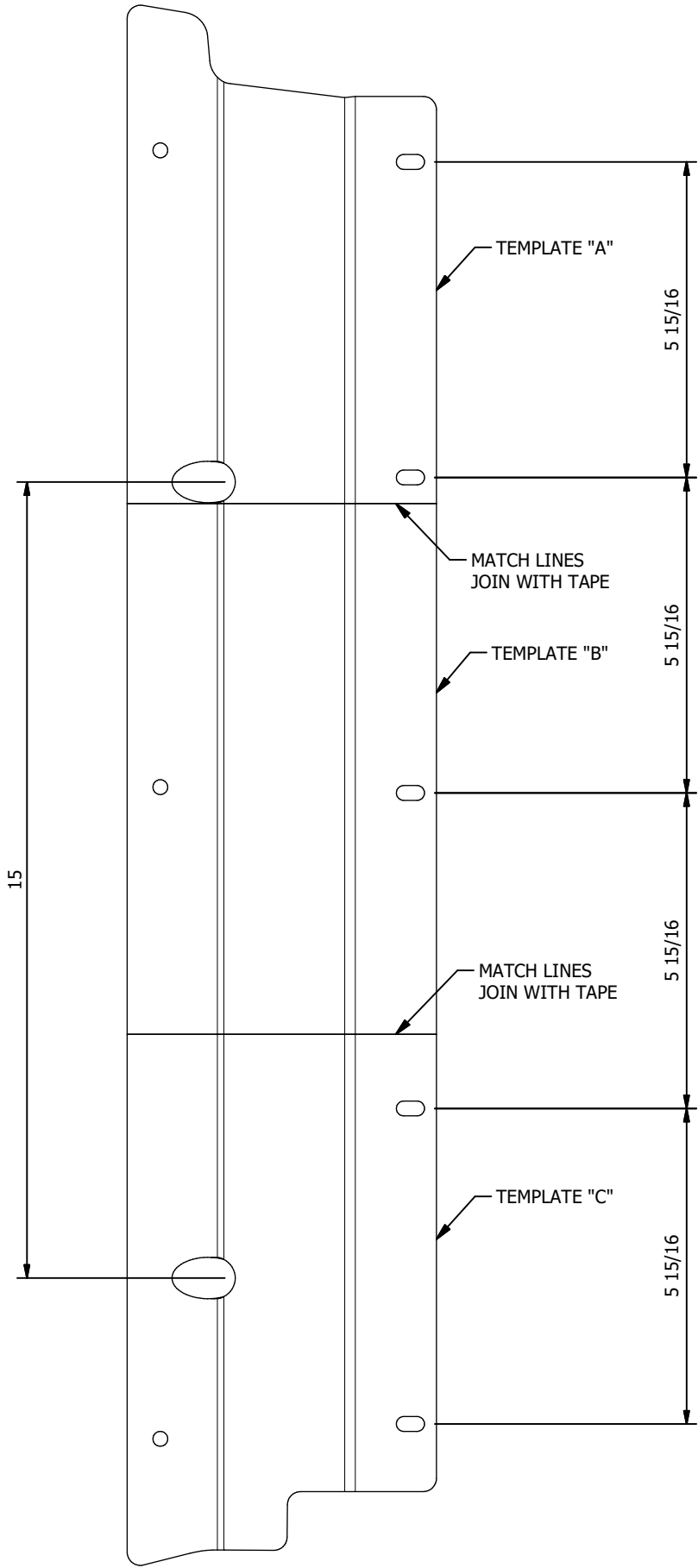

# MB3061 - Assembly Instructions Rear Soft Upper Window Adapter Kit JKU

## STEP 1

1. Remove five (5) existing screws from half door. NOTE: You will reuse all existing screws.
2. Fold & place joined paper template "A/B/C" over the door sill. Align holes shown.
3. Mark all large cutouts using a marker. Do NOT mark small holes using paper templates. Small holes will be marked in a later step.
4. Repeat marking on opposite half door.
5. Remove paper templates.
6. Cut out all large cutouts in half door.

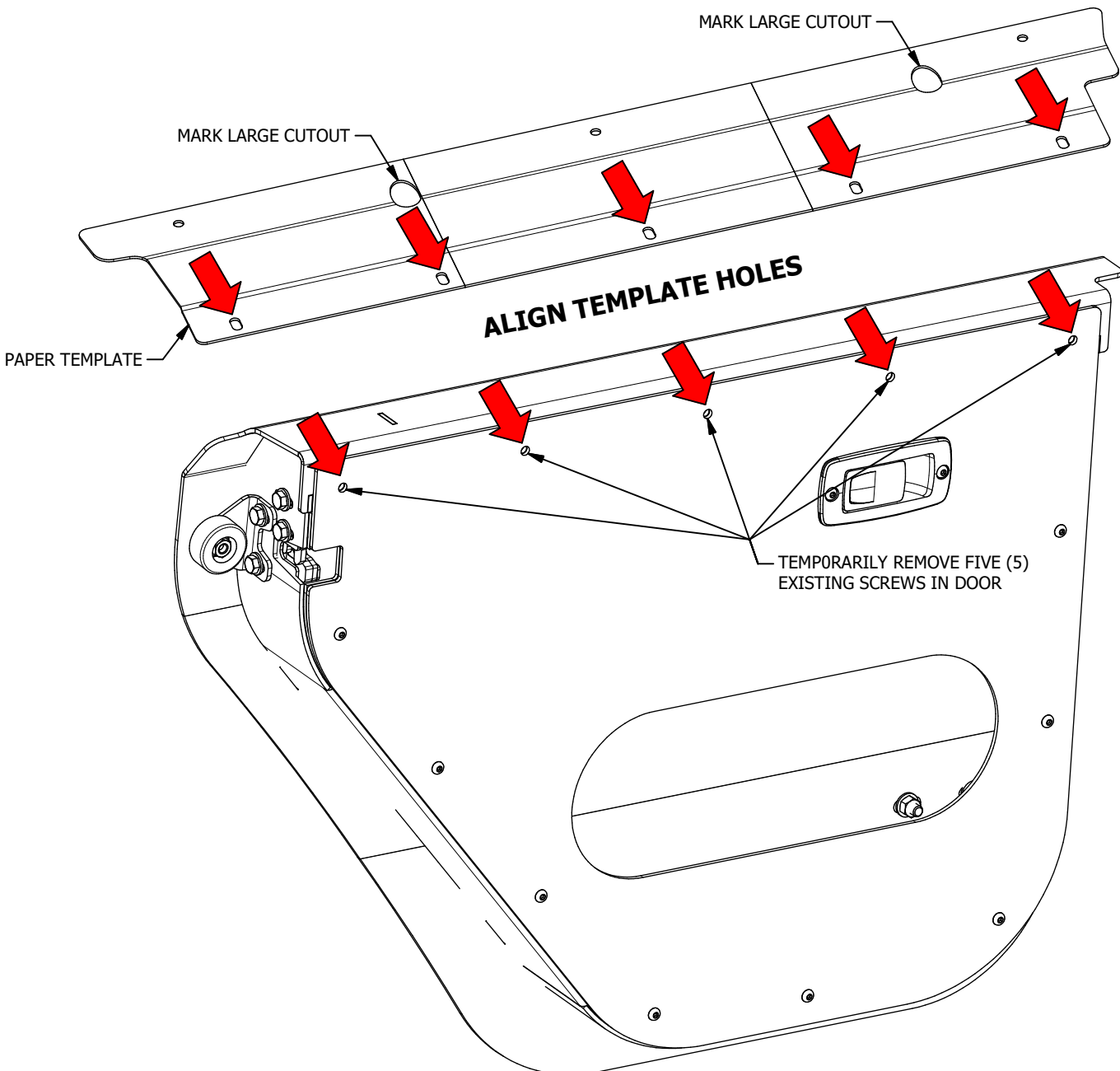



## MB3061 - Assembly Instructions Rear Soft Upper Window Adapter Kit JKU

### STEP 2

1. Remove the inner door skin from half door.
2. Place both the Sill weldment in position. The welded tubes in each Door Sill weldment should loosely clear the cutouts you made in the doors from Step 1.
3. Ensure the slotted holes in Sill weldment are aligned with the rivnuts in the half door.
4. Mark all remaining small holes.
5. Remove all weldments.
6. Drill all marked holes using 1/4" drill bit.

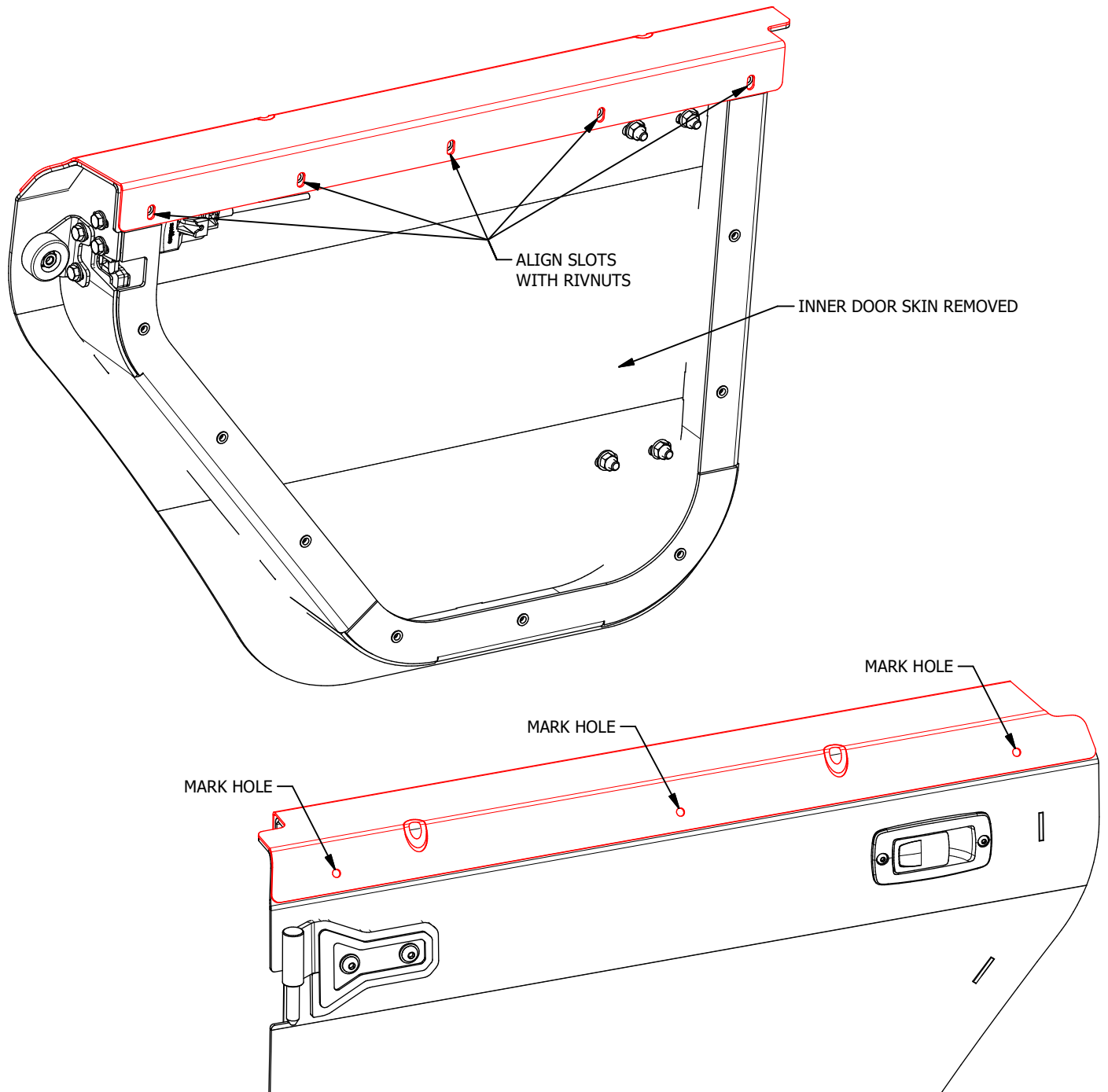

**MB3061 - Assembly Instructions Rear Soft Upper Window Adapter Kit JKU**
**STEP 3**

1. With the inner door skin still removed, install button head screws, flat washers & nylocks through all of the drilled holes.
2. Install inner door skin.
3. Install the five (5) existing button head screws shown.

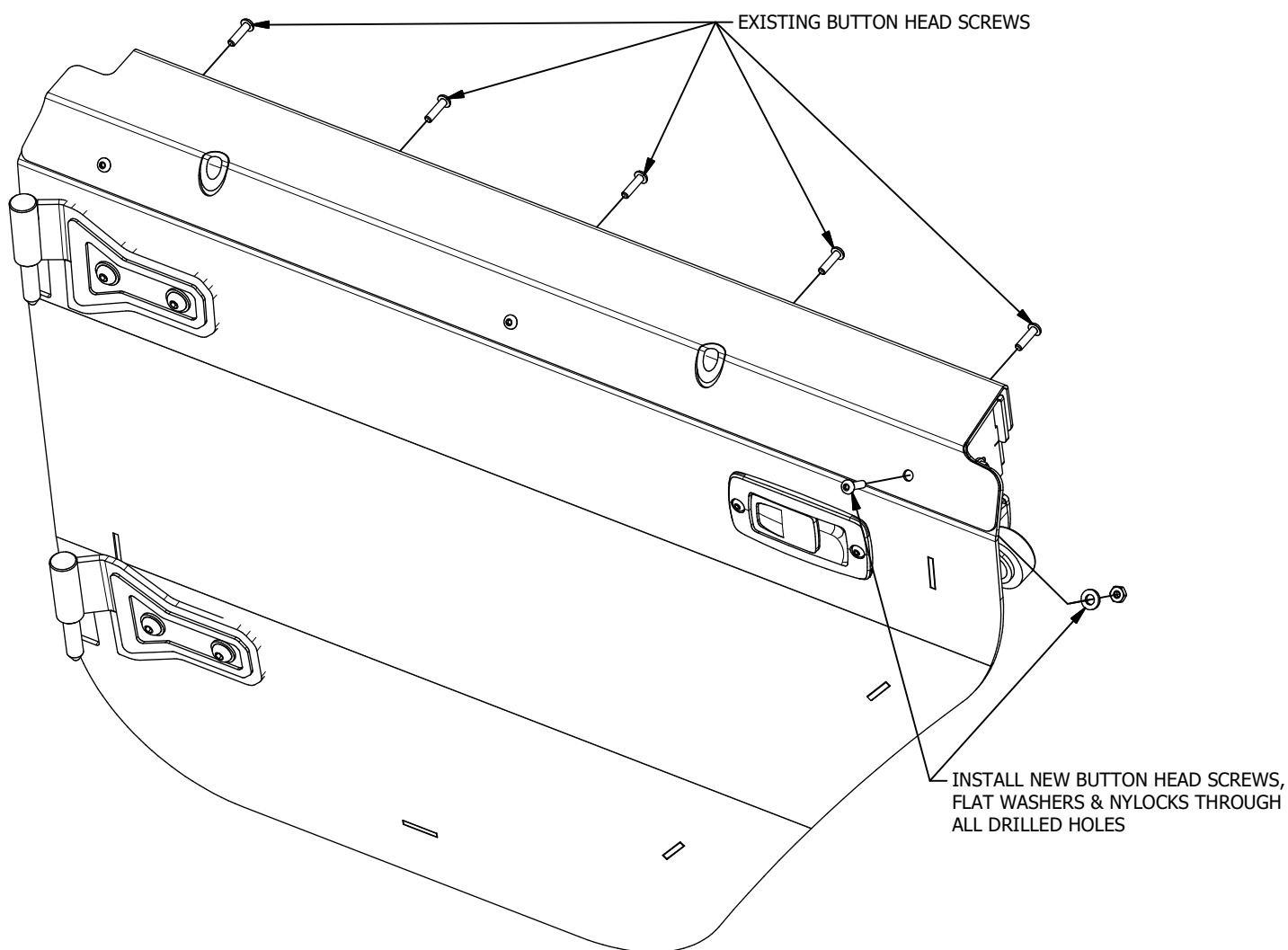

**MB3060 - Assembly Instructions Front Soft Upper Window Adapter Kit JKU****STEP 4  
INSTALL SOFT UPPER DOORS**