

# MB3033 - JKU Cage Knock Down Kit Assembly Instructions

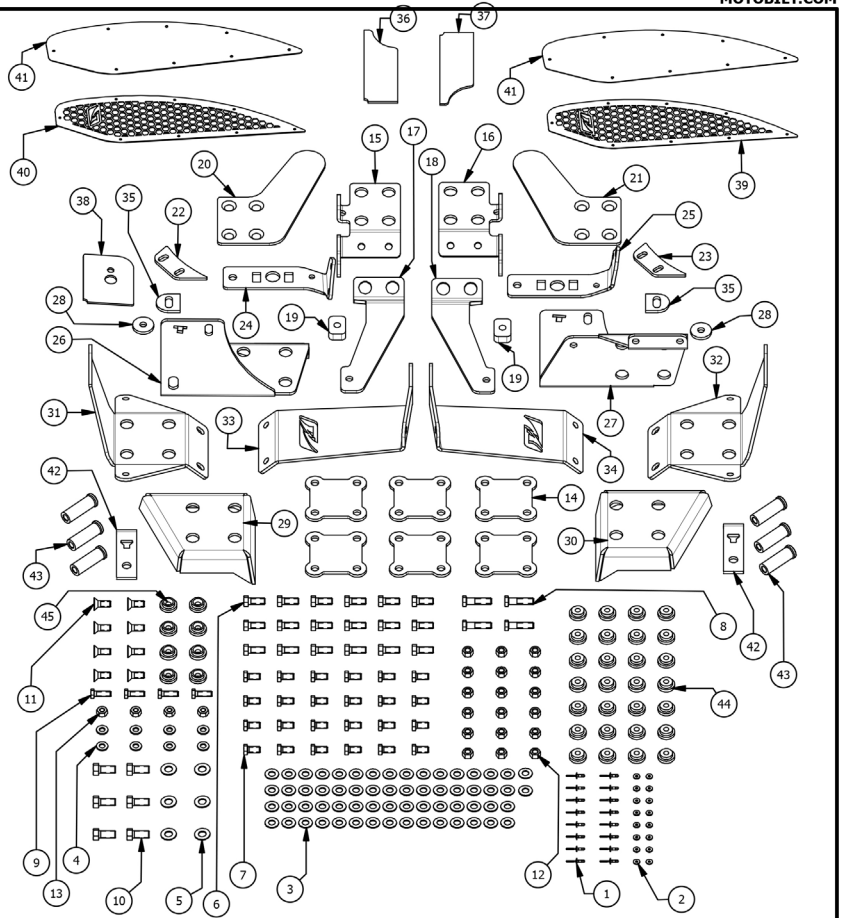

MOTOBILT.COM

PARTS LIST			
ITEM	QTY	PART NUMBER	DESCRIPTION
1	16	Dash Rivet 1/8 x 0.389	
2	16	Dash Rivet Washer 1/8	
3	62	Flat Washer, 3/8"	
4	8	Flat Washer, 5/16"	
5	6	Flat Washer, 7/16"	
6	18	Hex Bolt, 3/8"-16 UNC x 1.0"	
7	24	Hex Bolt, 3/8-16 UNC X 0.75"	
8	4	Hex Bolt, 3/8-16 UNC x 1.5"	
9	4	Hex Bolt, 5/16-18 UNC x 1"	
10	6	Hex Bolt, 7-16"-20 UNF x 1.0"	
11	8	Hex Countersunk, 3/18"-16 UNC x 1.0"	
12	18	Hex Nylock Nut, 3/8" - 16	
13	4	Hex Nylock Nut, 5/16" - 18	
14	6	MB3022	Pillar Base Plate
15	1	MB3032-01	Plate 01
16	1	MB3032-01_MIR	Plate 01_MIR
17	1	MB3032-02	Plate 02
18	1	MB3032-02_MIR	Plate 02_MIR
19	2	MB3032-03	Plate 03
20	1	MB3032-04	Plate 04
21	1	MB3032-04_MIR	Plate 04_MIR
22	1	MB3032-05A ver 2	Plate 05A
23	1	MB3032-05A ver 2_MIR	Plate 05A_MIR
24	1	MB3032-05B	Plate 05B
25	1	MB3032-05B_MIR	Plate 05B_MIR
26	1	MB3032-06	Plate 06
27	1	MB3032-06_MIR	Plate 06_MIR
28	2	MB3032-07	Plate 07
29	1	MB3032-08	Plate 08
30	1	MB3032-08_MIR	Plate 08_MIR
31	1	MB3032-09	Plate 09
32	1	MB3032-09_MIR	Plate 09_MIR
33	1	MB3032-10	Plate 10
34	1	MB3032-10_MIR	Plate 10_MIR
35	2	MB3032-11	Plate 11
36	1	MB3032-12	Plate 12
37	1	MB3032-12_MIR	Plate 12_MIR
38	1	MB3032-13	Plate 13
39	1	MB3032-14	Plate 14
40	1	MB3032-14_MIR	Plate 14_MIR
41	2	MB3032-15	Plate 15
42	2	MB3036	Seat Belt Mount
43	6	MB5514	Seat Belt Bung
44	28	Weld Nut 0.375 UNC	Weld Nut
45	8	Weld Nut 0.375 UNC w/ Countersink	Weld Nut Countersink
46	1	Standard (in)	



Dwg/Part No:  
**MB3032 KockDown - Shipping**  
 Description:  
**Jeep JKU Roll Cage Plate Kit**

Sheet No: **1** of **1**  
 Rev No: **0**

THIS DOCUMENT & THE INFORMATION CONTAINED WITHIN IS THE SOLE PROPERTY OF MOTOBILT INC. THIS DOCUMENT SHALL NOT BE COPIED, STORED, DUPLICATED, REVERSE ENGINEERED OR OTHERWISE WITHOUT THE EXPRESS WRITTEN CONSENT OF MOTOBILT INC. COPYRIGHT © MOTOBILT INC. COPYRIGHTED MATERIAL IS PROTECTED BY INTERNATIONAL COPYRIGHT LAWS. "MOTOBILT" IS A REGISTERED TRADE NAME.

# MB3033 – JKU Cage Knock Down Kit Assembly Instructions



MOTOBILT.COM

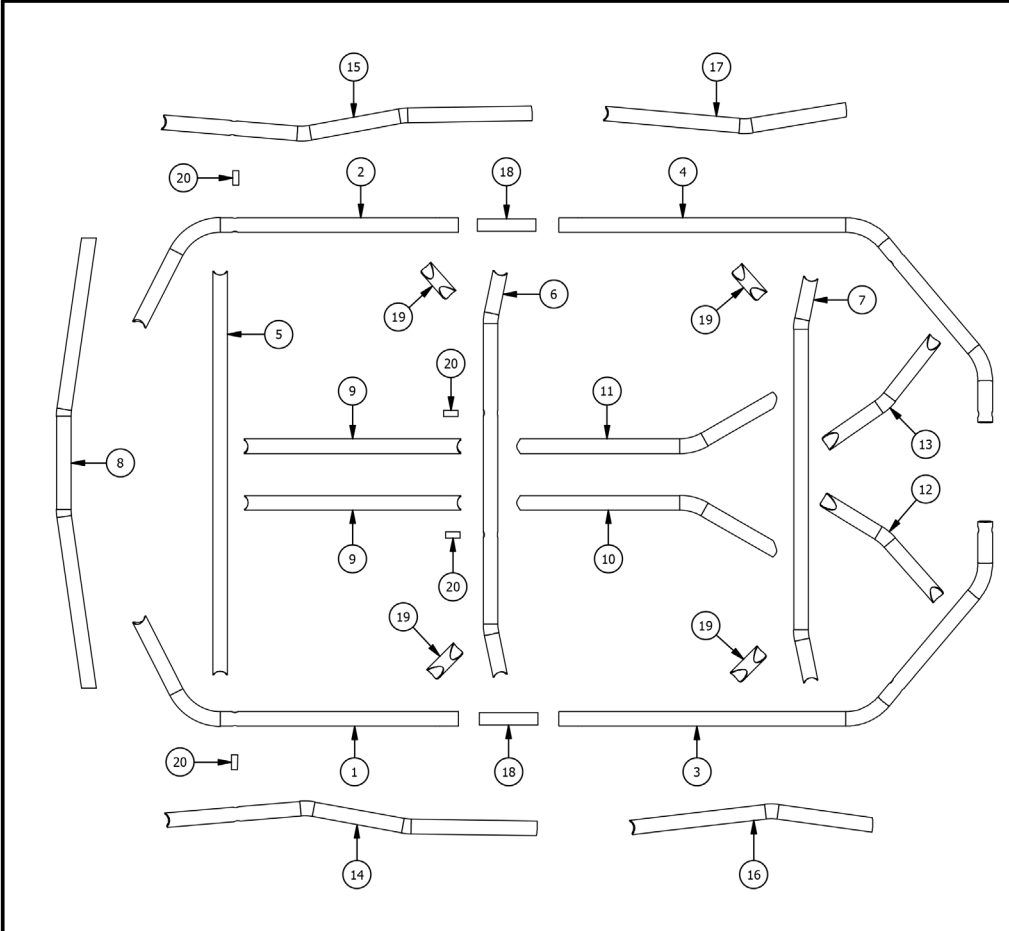

PARTS LIST			
ITEM	QTY	PART NUMBER	DESCRIPTION
1	1	MB3033-Tube 01	Tube 01
2	1	MB3033-Tube 02	Tube 02
3	1	MB3033-Tube 03	Tube 03
4	1	MB3033-Tube 04	Tube 04
5	1	MB3033-Tube 05	Tube 05
6	1	MB3033-Tube 06	Tube 06
7	1	MB3033-Tube 07	Tube 07
8	1	MB3033-Tube 08	Tube 08
9	2	MB3033-Tube 09	Tube 09
10	1	MB3033-Tube 10	Tube 10
11	1	MB3033-Tube 11	Tube 11
12	1	MB3033-Tube 12	Tube 12
13	1	MB3033-Tube 13	Tube 13
14	1	MB3033-Tube 14	Tube 14
15	1	MB3033-Tube 15	Tube 15
16	1	MB3033-Tube 16	Tube 16
17	1	MB3033-Tube 17	Tube 17
18	2	MB3033-Tube 18	Tube 18
19	4	MB3033-Tube 19	Tube 19
20	4	MB3033-Tube 20	Tube 20



Dwg/Part No:

**MB3033 - Shipping**

Description:

**Knock Down Tube Kit Contents**

Sheet No: **1** of **2**

Rev No: **0**

Matl:

THIS DOCUMENT & THE INFORMATION CONTAINED WITHIN IS THE SOLE PROPERTY OF MOTOBILT INC. THIS DOCUMENT SHALL NOT BE COPIED, STORED, DUPLICATED, REVERSE ENGINEERED OR OTHERWISE WITHOUT THE EXPRESS WRITTEN CONSENT OF MOTOBILT INC. COPYRIGHT © MOTOBILT INC. COPYRIGHTED MATERIAL IS PROTECTED BY INTERNATIONAL COPYRIGHT LAWS. "MOTOBILT" IS A REGISTERED TRADE NAME.

# MB3033 - JKU Cage Knock Down Kit Assembly Instructions

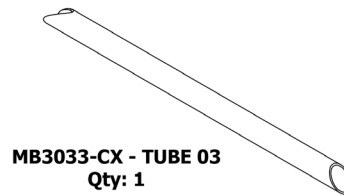
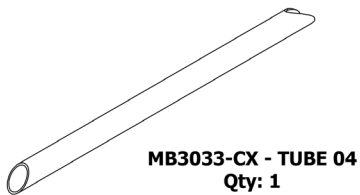
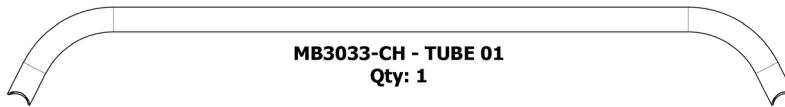
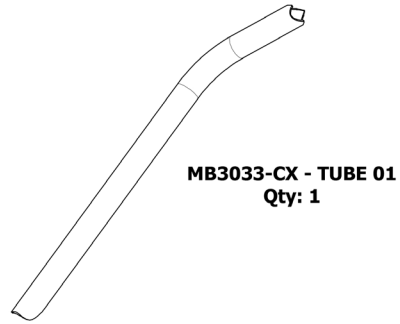
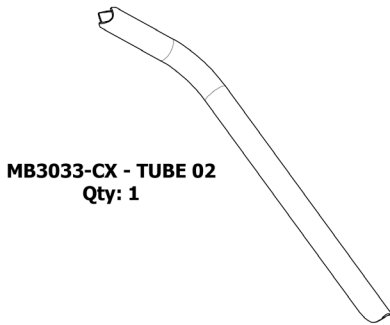
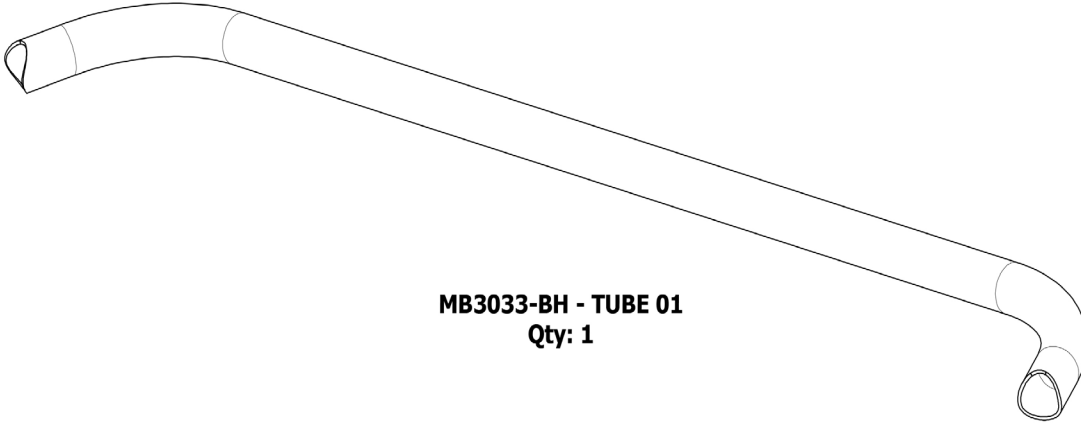

**MB3033 - JKU Cage Knock Down Kit Assembly Instructions**

**MB3033-GH - TUBE 01**  
Qty: 1

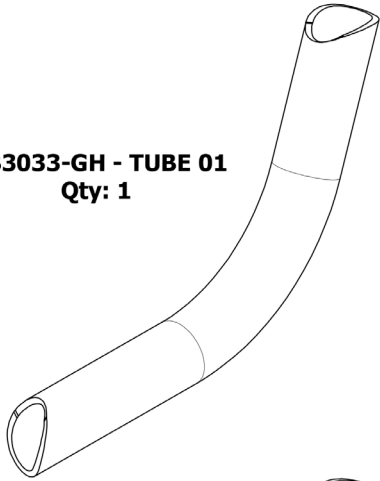

**MB3033-GH - TUBE 02**  
Qty: 1

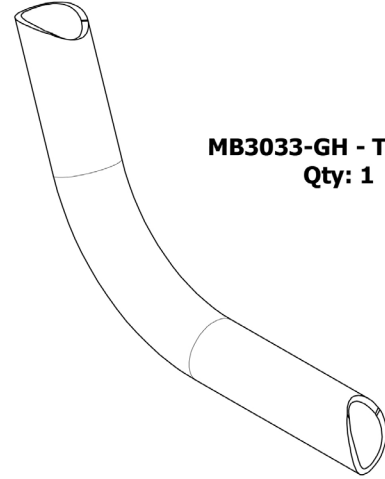

**MB3033-GH - TUBE 03**  
Qty: 1

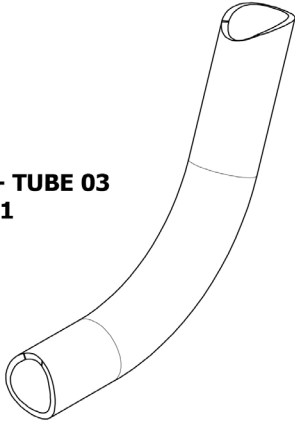

**MB3033-GH - TUBE 04**  
Qty: 1

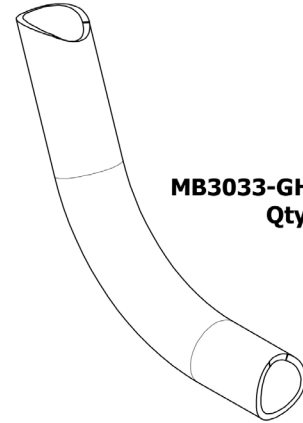



**MB3033 – JKU Cage Knock Down Kit Assembly Instructions**

**The factory interior must first be removed.**

**NOTE:**

Note: The dash and center console can remain in the vehicle, but will need to be protected from sparks during welding

- 1** Confirm that Jeep tub is level to the ground. This may require setting the Jeep on jack stands
- 2** Remove the negative battery terminal from the battery.
- 3** Remove the top from the Jeep.
- 4** Remove all doors
- 5** Starting from the front remove the driver seat by first unplugging the seat from the factory harness and then removing the four bolts mounting the seat bracket to the Jeep tub. (13mm socket)
- 6** Remove the front passenger seat by first unplugging the seat from the factory harness and then removing the four bolts mounting the seat bracket to the Jeep tub. (13mm socket)
- 7** Remove the rear seat by removing the eight bolts and two nuts fastening it to the Jeep tub. See picture below for marked bolt locations. (13mm and 18mm socket)



**MB3033 – JKU Cage Knock Down Kit Assembly Instructions**

- 8** Remove the plastic trim surrounding the windshield. (Philips Screws)
- 9** Remove the driver and passenger sun visors. (T-20) (Hardware will be re-used)
- 10** Remove the plastic trim surrounding the B-Pillar
- 11** Remove the rear sub-woofer if equipped and rear plastic trim. (10mm socket)
- 12** Remove the stock seat belt retractors and seat belts (Torx T-50 and T45) front and rear. The bolts retaining the seat belt retractors can be difficult to remove. This is normal due to the factory thread locker but be careful not to strip them. The front seat belt retractors reuse the OEM hardware. New hardware is included for the rear seat belt retractors
- 13** Remove all the interior carpeting
- 14** Unplug then remove the rear soundbar and dome light.
- 15** Unplug and remove the trunk over head dome light by unclipping it from the factory cage.
- 16** Remove the rear soft top brackets if equipped. (10mm) (Will be re-used)
- 17** Remove the factory roll bar padding and foam.
- 18** Unplug then remove the factory GPS antenna if equipped. (10mm) (hardware is re-used)
- 19** Detach the wiring harness from the passenger side B-pillar that connects to the GPS antenna and sound bar.
- 20** Unplug the wiring harness from the windshield frame and move aside.

**Removing the stock cage**

- 21** Unbolt the front cage tubes that attach the B-Pillar to the windshield frame. (13mm)
- 22** Remove the windshield wipers
- 23** Remove the windshield brackets (T-40)

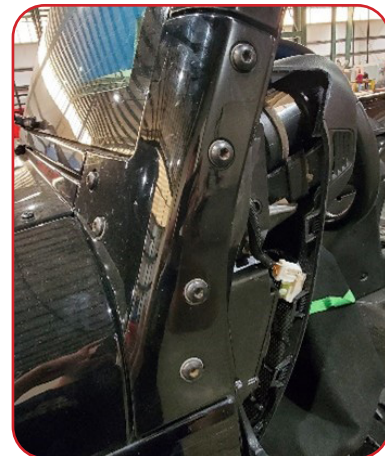

**MB3033 – JKU Cage Knock Down Kit Assembly Instructions**

- 24** Fold the windshield down. Cover and protect the windshield glass from welding sparks to avoid damage.

**When cutting the factory cage protect all exposed metal from corrosion**

- 25** Starting at the D-pillar, cut the factory cage off the tub on both sides of the vehicle. Cut the cage as close to the factory base as possible.

- 26** After cutting the D-pillar, cut the factory cage from the B-pillar. This is a rough cut to remove the cage and will be trimmed later for fitment.

**CUT THE FACTORY CAGE AT THE RED LINES AT FOUR CORNERS**

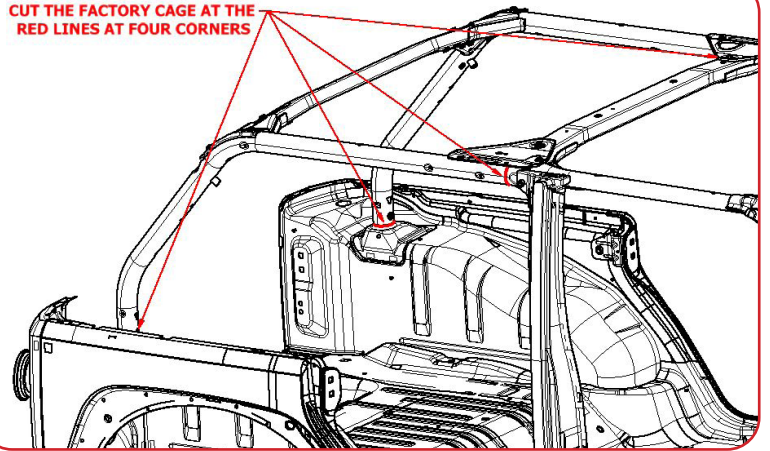

- 27** Remove the factory cage and set aside.
- 28** Cut off the stud that is in front of D-pillar on the driver and passenger side.
- 29** Grind or cut the factory D-pillar so that it is flush with the base. This will be covered over with a plate provided in the kit.



**MB3033 – JKU Cage Knock Down Kit Assembly Instructions**

- 30** Trim what is left of the factory cage to the b-pillar. Make sure not to cut past the factory interior threaded hole. There is a tab in the cage that will be utilizing the threaded hole tie in the factory b-pillar to the Motobilt cage.

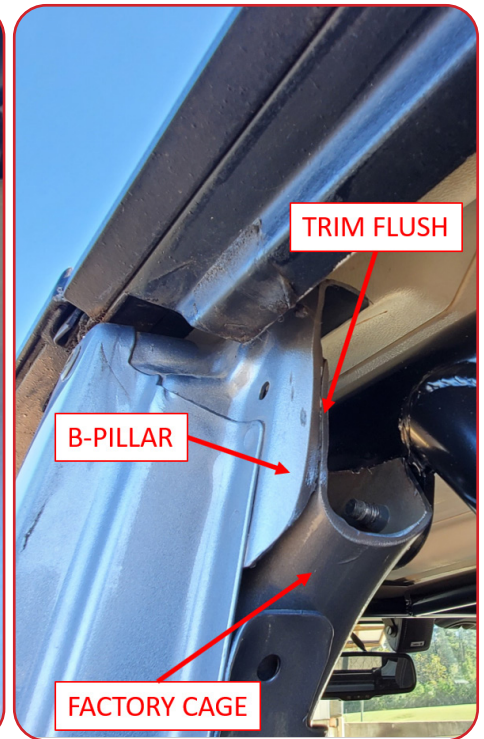

- 31** Weld the provided 0.375UNC Countersunk weld nuts to MB3032-01 and MB3032-01\_MIR. Four weld nuts per plate.

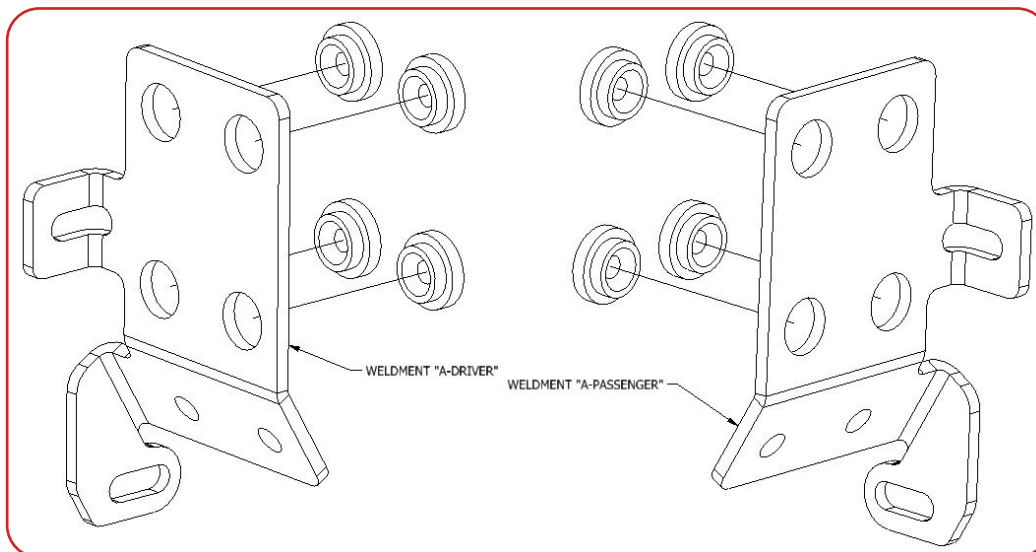

**MB3033 – JKU Cage Knock Down Kit Assembly Instructions**

- 32** Weld the spacer plate and weld nuts to MB3032-02 and MB3032-02\_MIR. Two weld nuts and one spacer per plate.

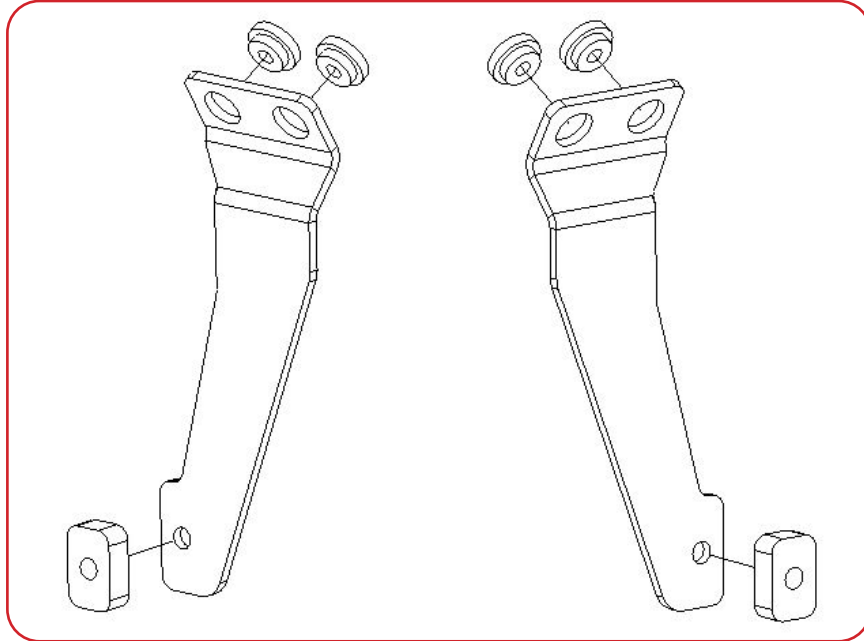

- 33** Weld the weld nuts and MB3032-07 spacer plate to MB3032-06 and MB3032-06\_MIR. Four weld nuts and one spacer per plate.

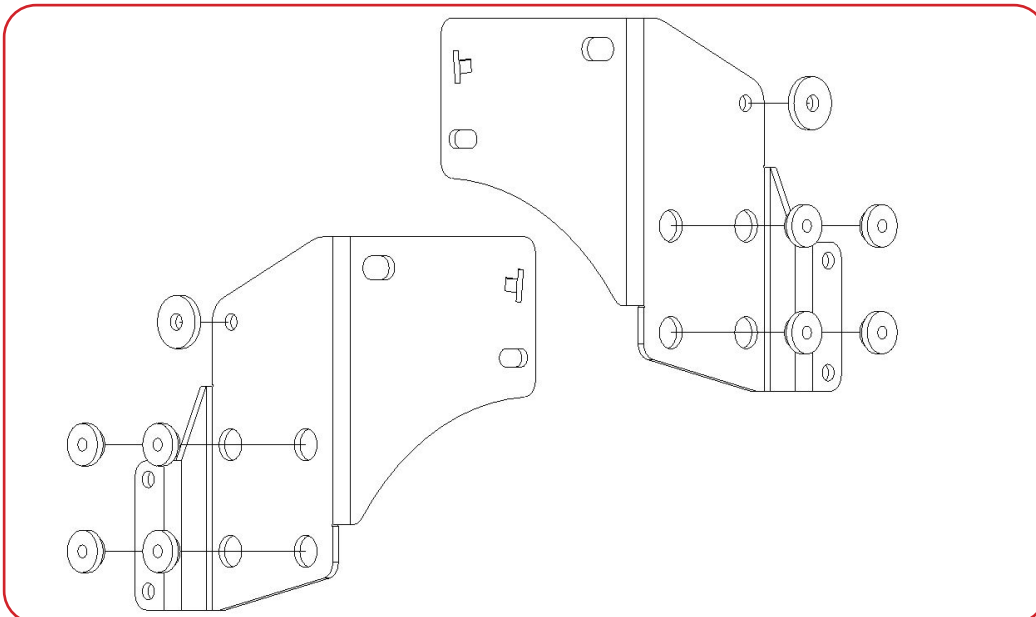

**MB3033 – JKU Cage Knock Down Kit Assembly Instructions**

- 34** Weld the weld nuts to MB3032-09 and MB3032-09\_MIR. Four weld nuts and one spacer per plate.

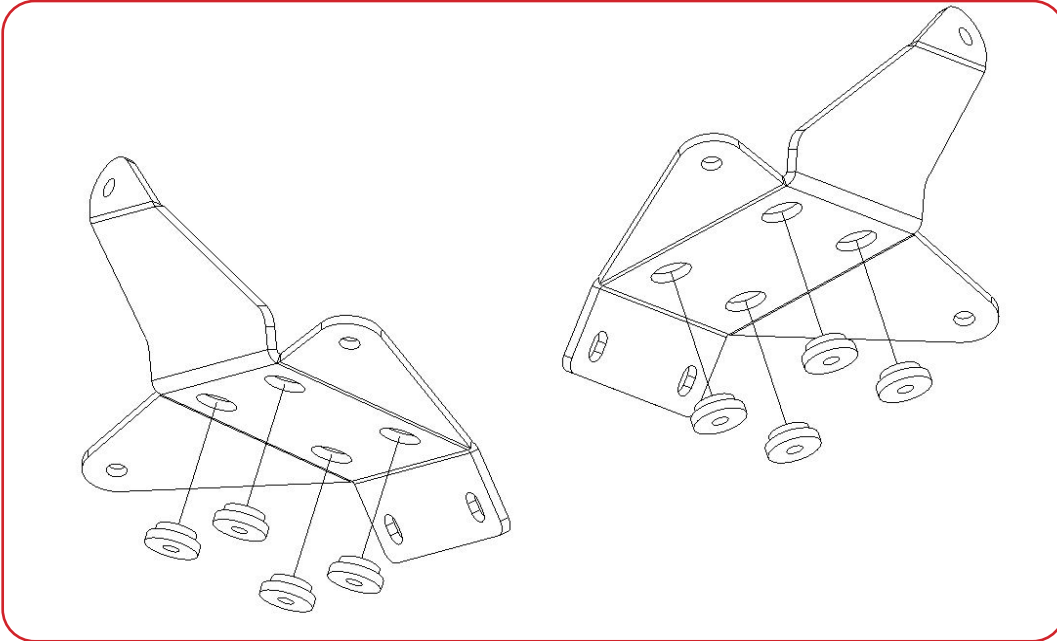

- 35** Weld the weld nuts to MB3032-08 and MB3032-08\_MIR. Four weld nuts and one spacer per plate. Then weld the four corner seams.

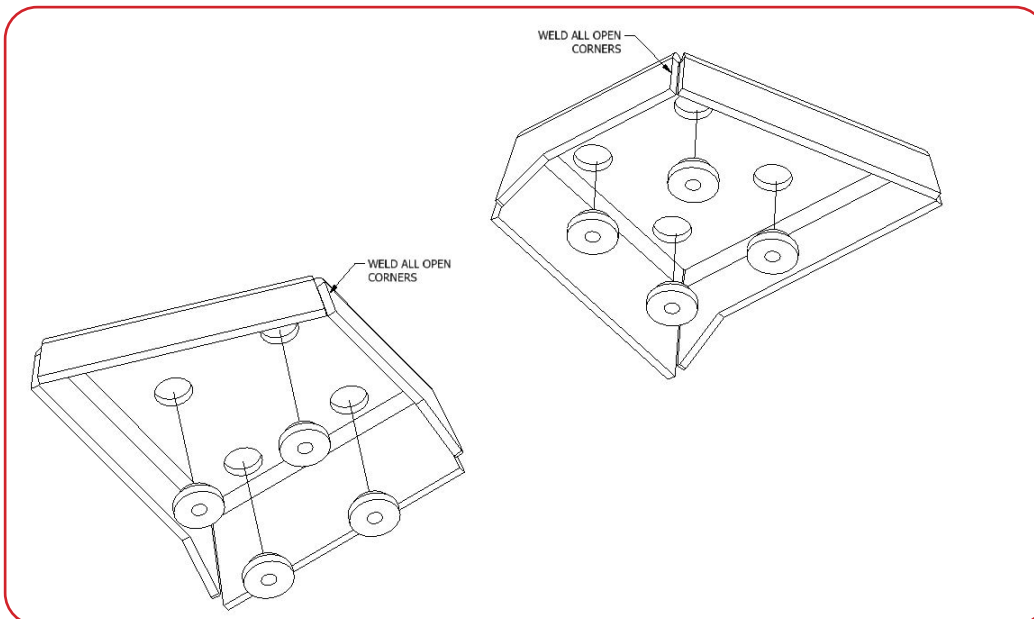

**MB3033 – JKU Cage Knock Down Kit Assembly Instructions****Setting the A-Pillar [Reference Assembly Drawing: MB3032 – A-Pillar]**

- 36** Remove the plastic trim on each side of the dash. Starting on the drivers side remove the two 6mm bolts (10mm socket) that are securing the aluminum dash structure to the tub. These bolts will be reused. Take plate MB3032-01 and test for fitment. The aluminum dash will need to be trimmed to allow MB3032-01 to fit properly. Once the aluminum dash structure has been properly trimmed back, fasten MB3032-01 to the aluminum dash structure using the two factory bolts that were previously removed. Do not fully tighten.

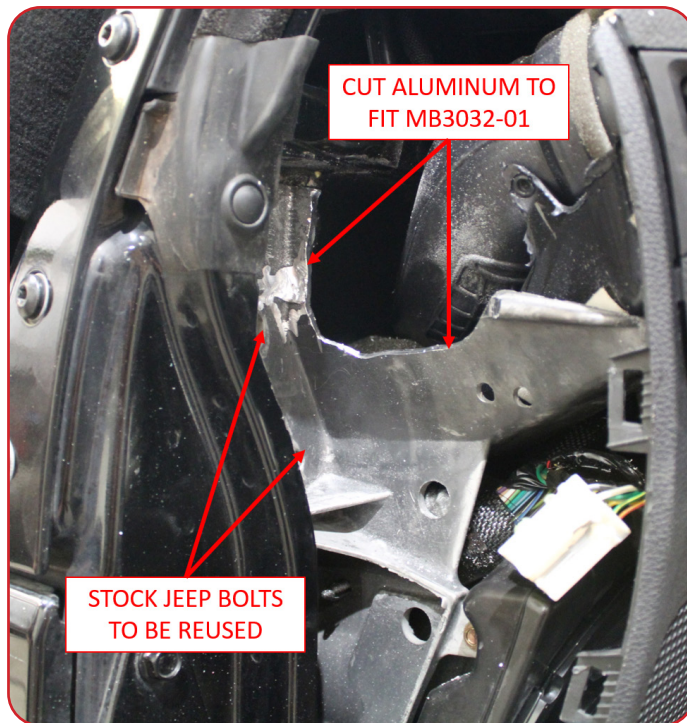

- 37** Install MB3032-02 by sliding the top of the plate with the two weld nuts installed behind plate MB3032-01. The spacer plate welded to MB3032-02 should be behind the pinch weld. Fasten MB3032-02 to MB3032-01 by hand tightening two 3/8"-16 x 1" hex bolts and two 3/8" washer into the weld nuts on plate MB3032-02.



**MB3033 – JKU Cage Knock Down Kit Assembly Instructions****Setting the A-Pillar [Reference Assembly Drawing: MB3032 – A-Pillar]**

- 38** Fasten plate MB3032-04 to MB3032-01 using four 3/8"-16 X 1" hex countersunk bolts.

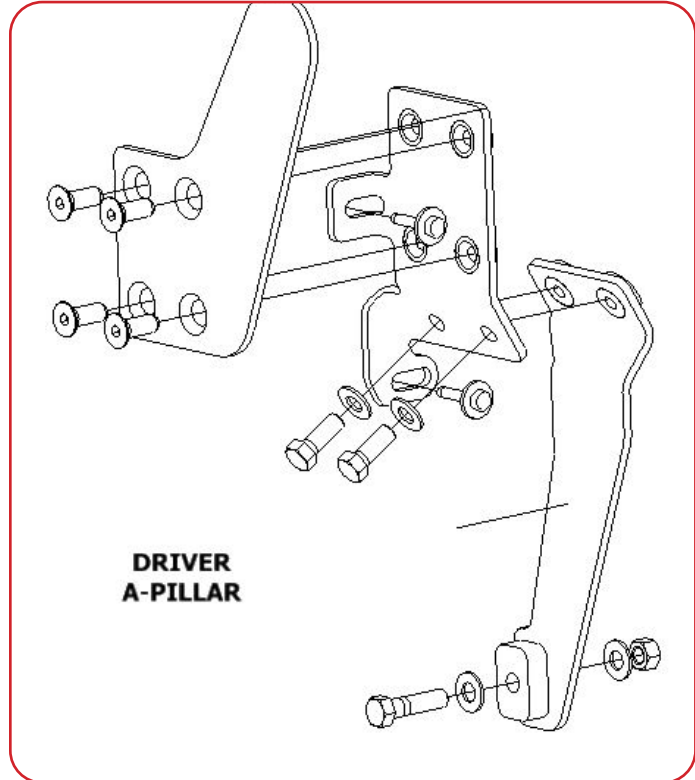

- 39** Measure and confirm there is a space between face of plate MB3032-04 and the factory seam weld of 1-1/8". This allows the dash side trim panel to be remounted.

- 40** Repeat steps 36-38 for the passenger side.

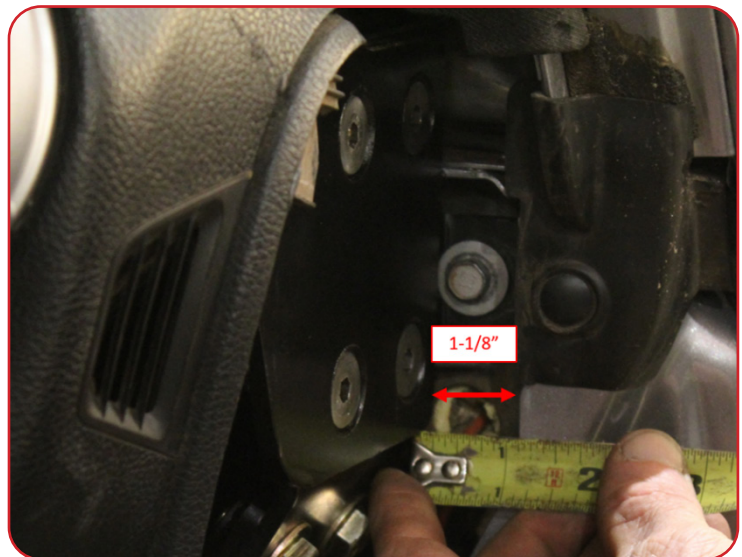



**MB3033 – JKU Cage Knock Down Kit Assembly Instructions****Setting the B-Pillar [Reference Assembly Drawing: MB3032 – B-Pillar]**

**41** Unclip the wiring harness that is routed on the floor the Jeep by the B-pillar and move it out of the way.

**42** Grind off the stud on the floor near the B-pillar that is used to attach the harness.

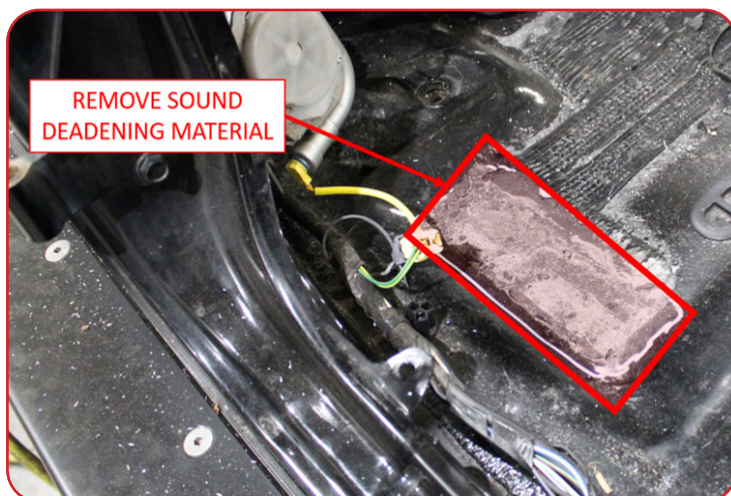

**43** Scrape away the factory sound deadening material to allow MB3032-06 to sit flat to the body

**MB3033 – JKU Cage Knock Down Kit Assembly Instructions****Setting the B-Pillar [Reference Assembly Drawing: MB3032 – B-Pillar]**

- 44** Bolt plate MB3032-06 to the Jeep tub using the factory Jeep bolt and factory Jeep seatbelt retractor bolt



- 45** Mark the three holes that need to be drilled. Drill the three holes that bolt MB3032-06 to the tub floor to allow a 3/8" bolt to pass through.

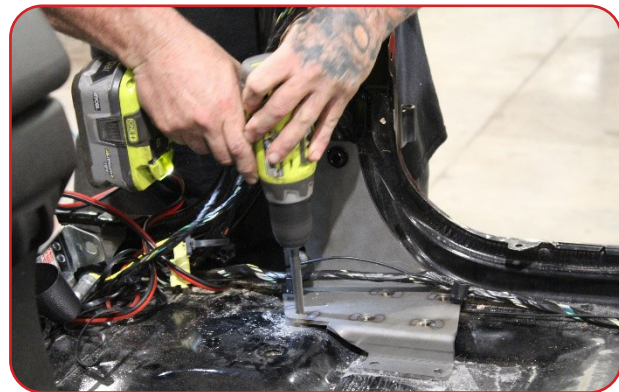
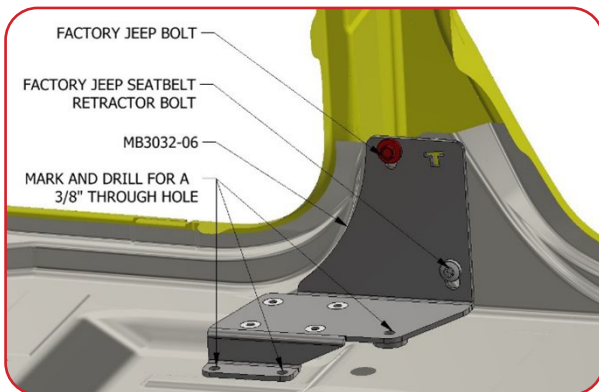

- 46** After drilling bolt MB3032-06 back to the place and fasten using the two factory bolts that attach to the B-pillar and the three 3/8" bolts that bolt through the tub. The factory wiring harness should be above the plate and not pinched between the B-pillar mount and the body.



**MB3033 – JKU Cage Knock Down Kit Assembly Instructions****Setting the B-Pillar [Reference Assembly Drawing: MB3032 – B-Pillar]**

- 47** Now bolt MB3022 to MB3032-06 two the four weld nuts using 3/8"UNC x 3/4" hardware provided.
- 48** Tighten hardware and repeat steps 40-46 on the passenger side

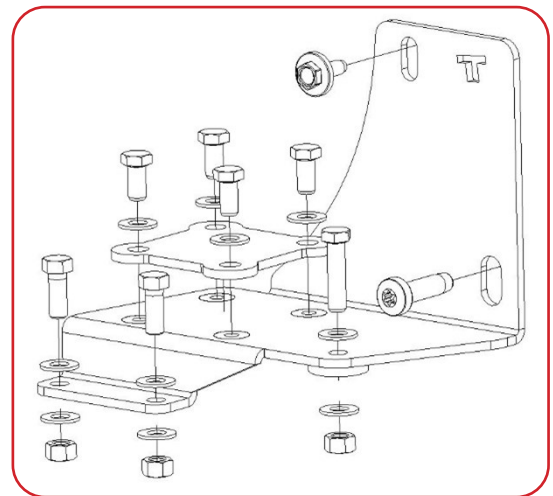
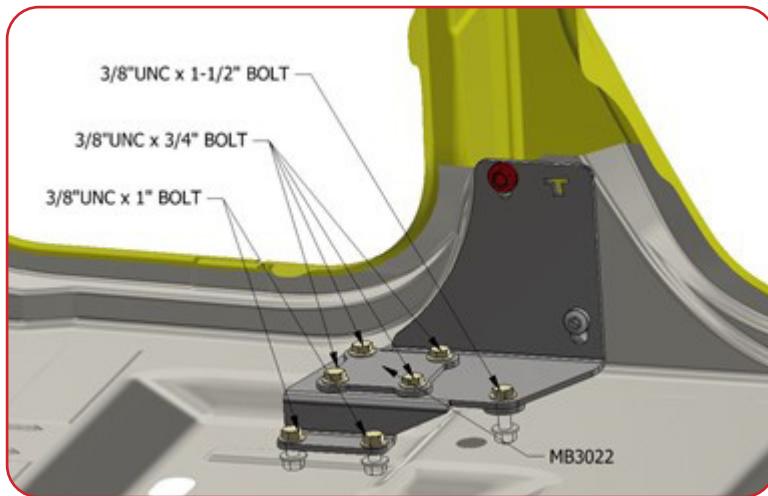
**Setting the C-Pillar [Reference Assembly Drawing: MB3032 – C-Pillar]**

- 49** Bolt MB3032-09 to MB3032-10 using the provided 3/8" hardware.
- 50** Mount the bolted assembly to the tub using the factory bolt and stud.



**MB3033 – JKU Cage Knock Down Kit Assembly Instructions****Setting the C-Pillar [Reference Assembly Drawing: MB3032 – C-Pillar]**

- 51** Mark the three holes that need to be drilled. Drill the three holes that bolt the assembly to the tub floor to allow a 3/8" bolt to pass through

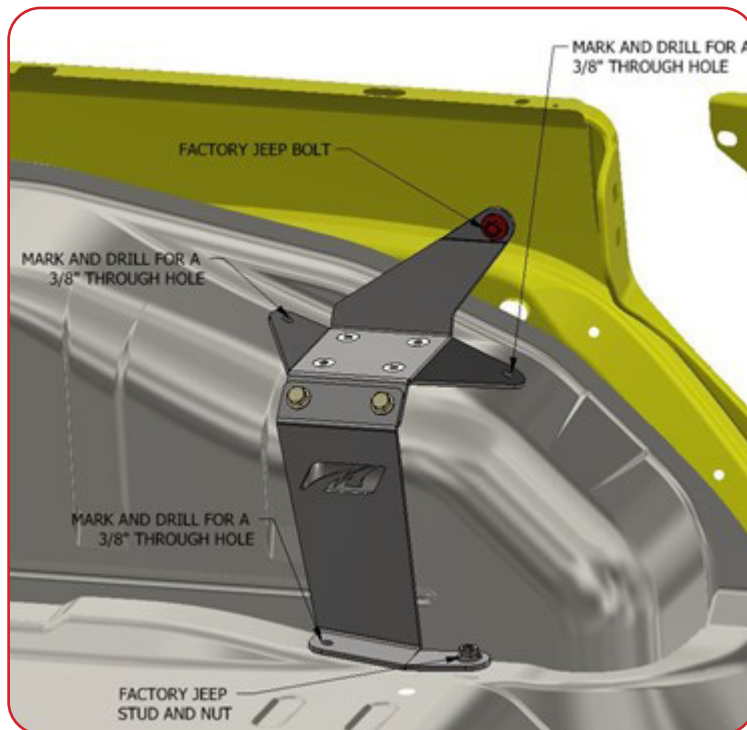

- 52** Fasten the assembly MB3032-09 and MB3032-10 to the Jeep tub using the provided 3/8" hardware for the holes that were drilled and the factory hardware.

**MB3033 – JKU Cage Knock Down Kit Assembly Instructions****Setting the D-Pillar [Reference Assembly Drawing: MB3032 – D-Pillar]**

**55** Set plate MB3032-08 on top of where the stock Jeep cage was cut off. MB3032-08 should seat itself, if not the stock cage may need to be trimmed down further. The long edge should face towards the front of the Jeep and the short edge should be rear facing

**56** With the Jeep level, level the top surface of plate MB3032-08

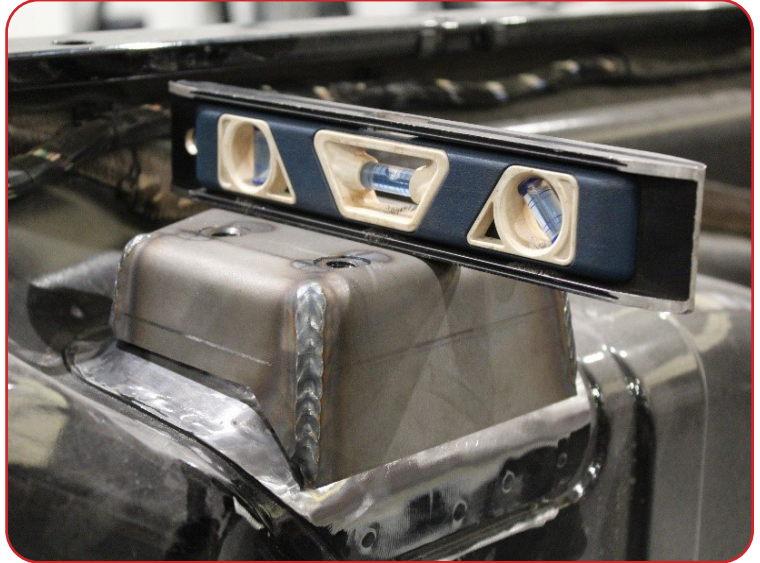

**57** Mark the area at the bottom of MB3032-08 where it meets the tub. Remove the plate and grind the tub down to the bare metal 1/2" above and below the line to prepare for welding.

**58** Tack MB3032-08 to the tub and confirm the plate top surface is still level. Then weld the bottom edges of MB3032-08 directly to the Jeep tub around the perimeter.

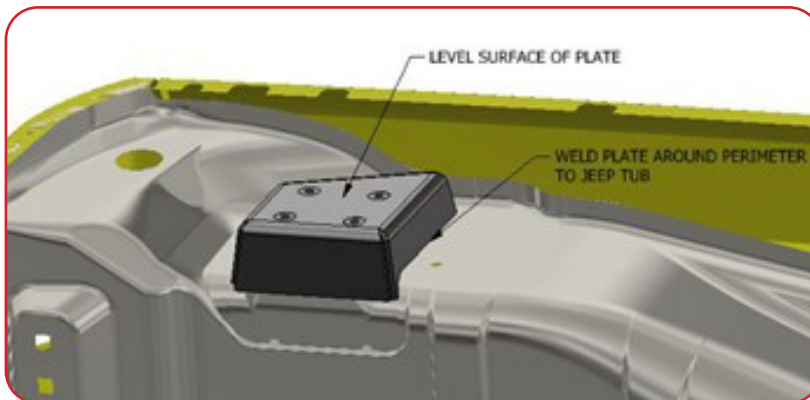



**MB3033 – JKU Cage Knock Down Kit Assembly Instructions****Setting the D-Pillar [Reference Assembly Drawing: MB3032 – D-Pillar]**

- 59** Bolt MB3022 to MB3032-08 using the provided 3/8" hardware.
- 60** Tighten hardware and repeat steps 54-58 on passenger side

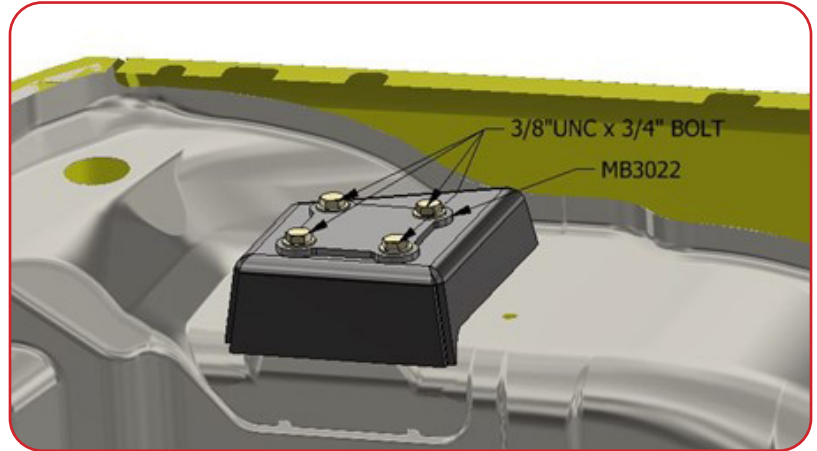
**Tube Preparation**

- 61** Insert the one tube sleeve MB3033-20 into MB3033-Tube 01. Grind the weld down smooth to the surface of the tube. Repeat on MB3033-Tube 02.

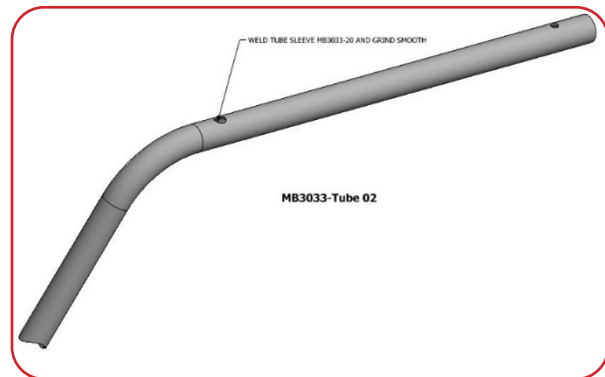
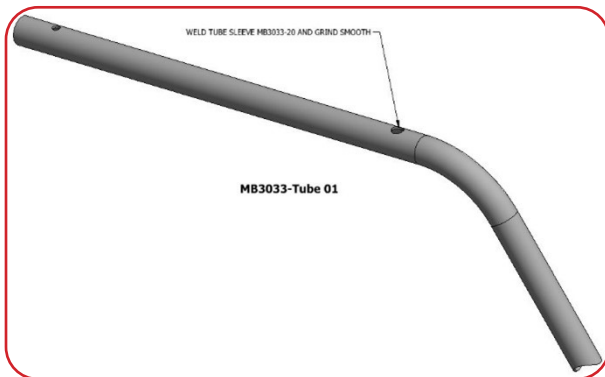

## MB3033 – JKU Cage Knock Down Kit Assembly Instructions

- 62** Insert two tube sleeves into MB3033-20 into MB3033-06. Grind the welds down smooth to the surface of the tube.

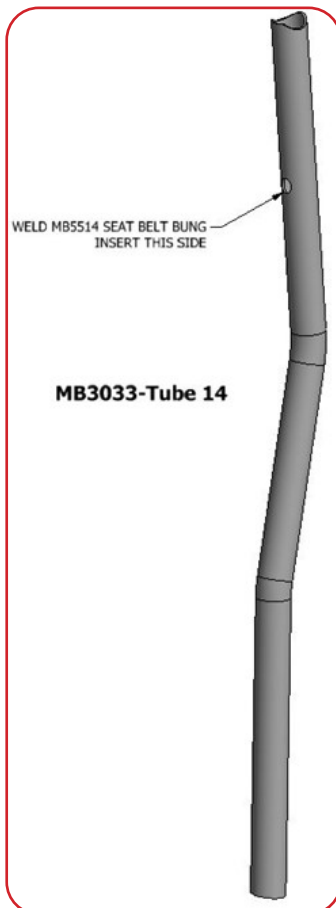
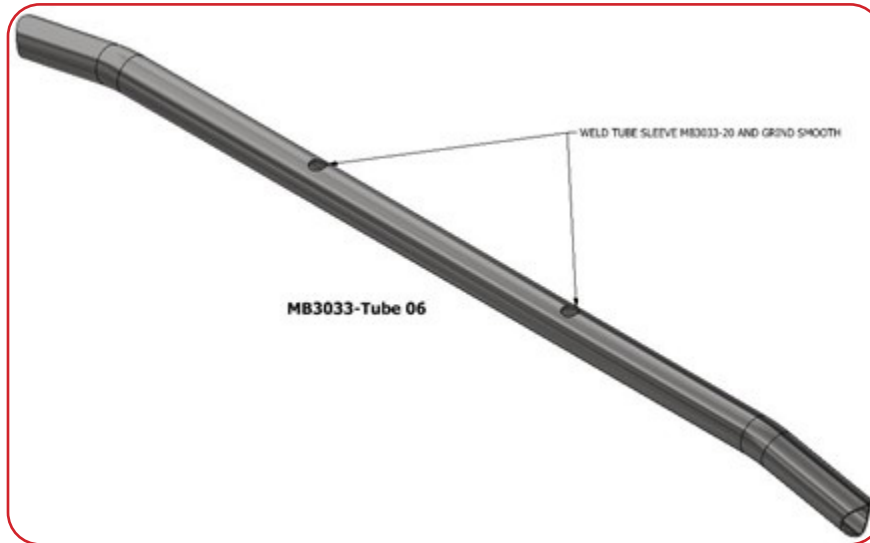

- 63** Weld one seat belt bung MB5514 into tube MB3033-Tube 14 and another seat belt bung MB5514 into tube MB3033-Tube 15.

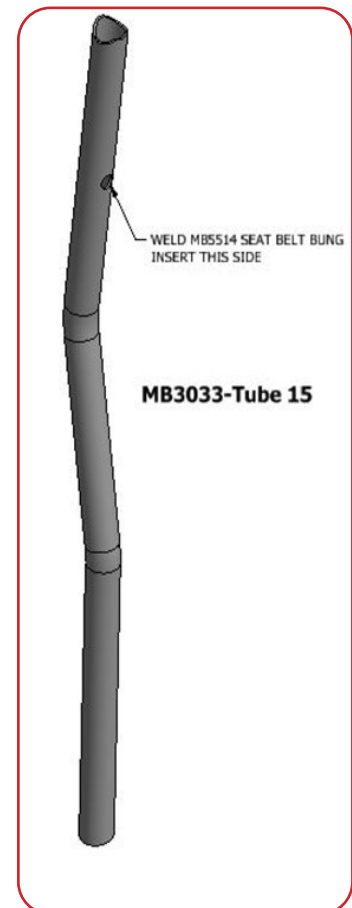

**MB3033 – JKU Cage Knock Down Kit Assembly Instructions**

- 64** Weld two seat belt bungs MB5514 into tube MB3033-Tube 03 and another two seat belt bungs MB5514 into tube MB3033-Tube 04.

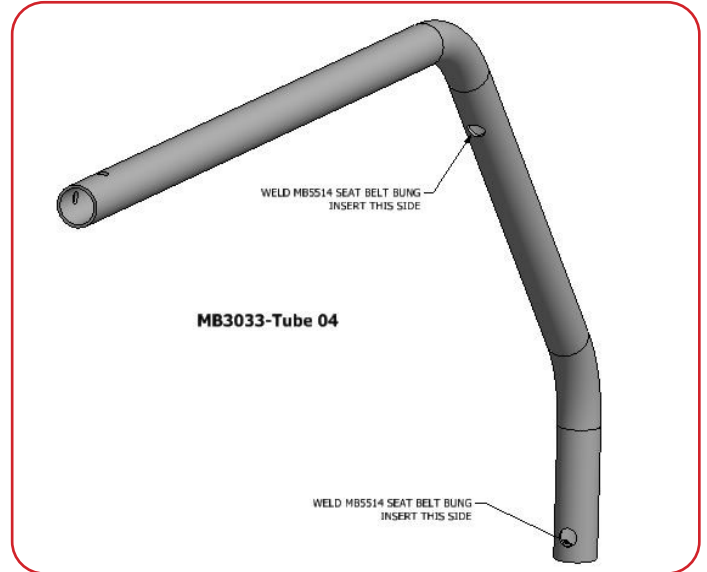
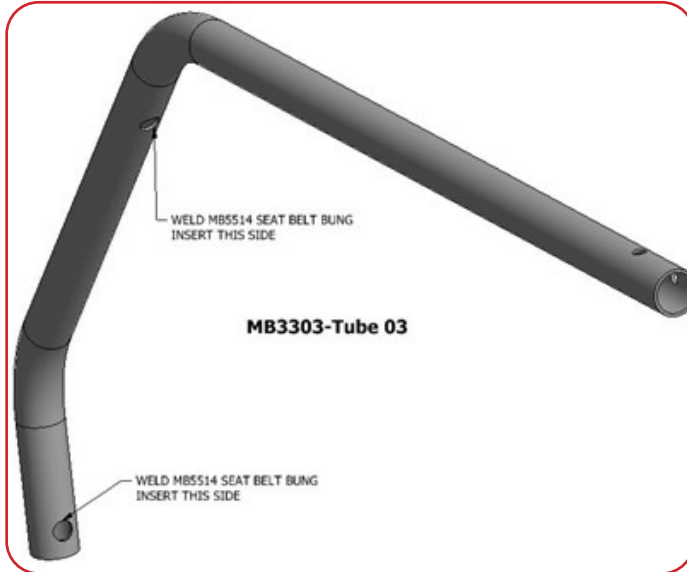

- 65** Insert the inner tube sleeve MB3033-Tube 18 into the end of MB3033-Tube 01 3-1/2" inches into the tube. Tack weld the tube at the plug weld holes to tube MB3033-Tube 18. Repeat on tube MB3033-Tube 02.

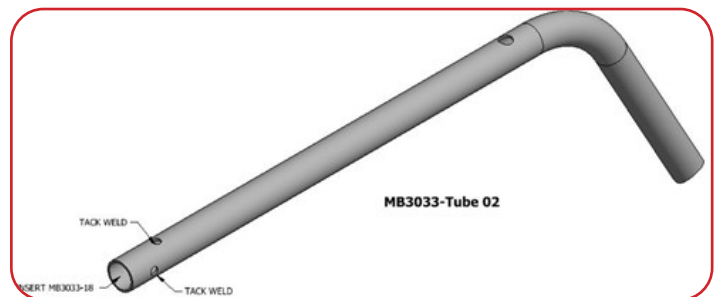
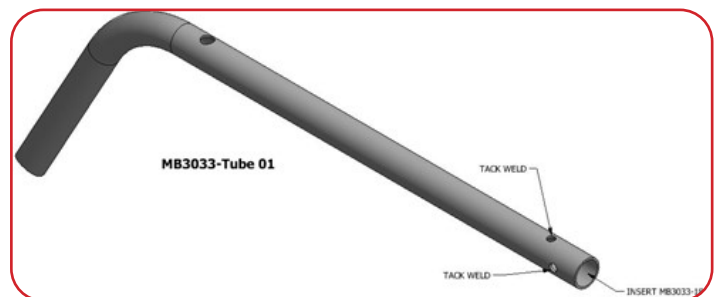



## MB3033 – JKU Cage Knock Down Kit Assembly Instructions

- 66** Assembling the side hoops. Lay MB3033-Tube 01 on a flat surface with the tack weld for MB3033-Tube 18 facing up. Insert MB3033-Tube 03 into the other end of MB3033-Tube 18. MB3033-Tube 03 should now be sleeved onto MB3033-Tube 18 and touching MB3033-Tube 01. Raise the notched end of MB3033-Tube 01 one inch off the ground creating a twist in the tube assembly. Tack weld the tube at the plug weld holes to tube MB3033-Tube 18. Repeat on tube MB3033-Tube 02 and MB3033-Tube 04 on the passenger side.

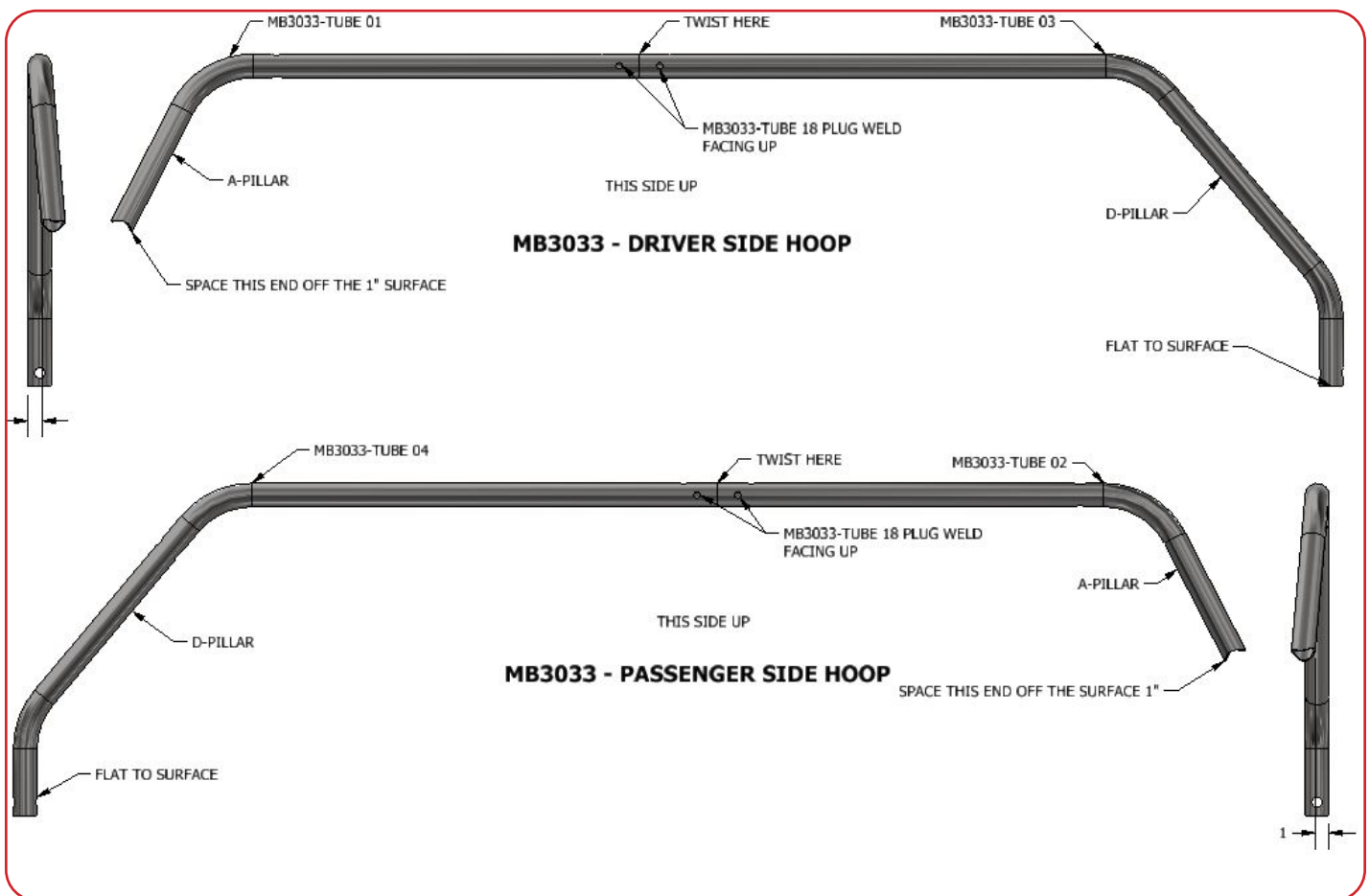

**MB3033 – JKU Cage Knock Down Kit Assembly Instructions**

- 67** Install the dash cross MB3033-Tube 08 with the bend facing out towards the front of the jeep. The ends of the tube should be flush with MB3032-04 and MB3032-04\_MIR and centered on the radius on the top of the plate leaving an 1/8" reveal for welding. Use a spacer to space the center of the tube 1/2" from the top dash. Once the tube is in place tack weld MB3033-Tube 08 to MB3032-04 and MB3032-04\_MIR.

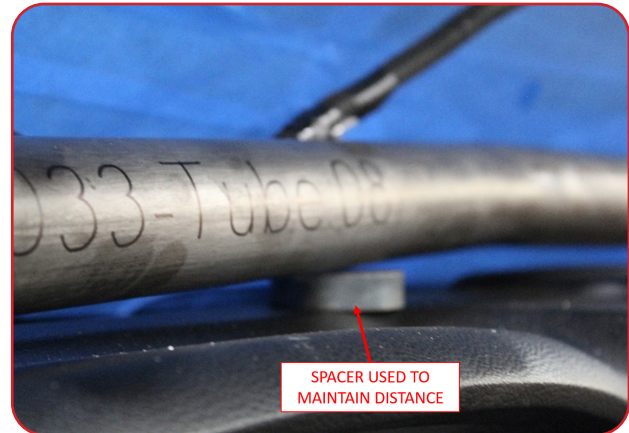
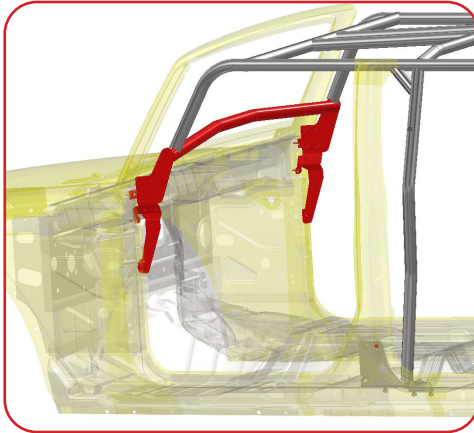

- 68** Attach MB3032-05B to the windshield using the factory hardware. Bolt MB3032-05A to MB3032-05B using the supplied 5/16" hardware.

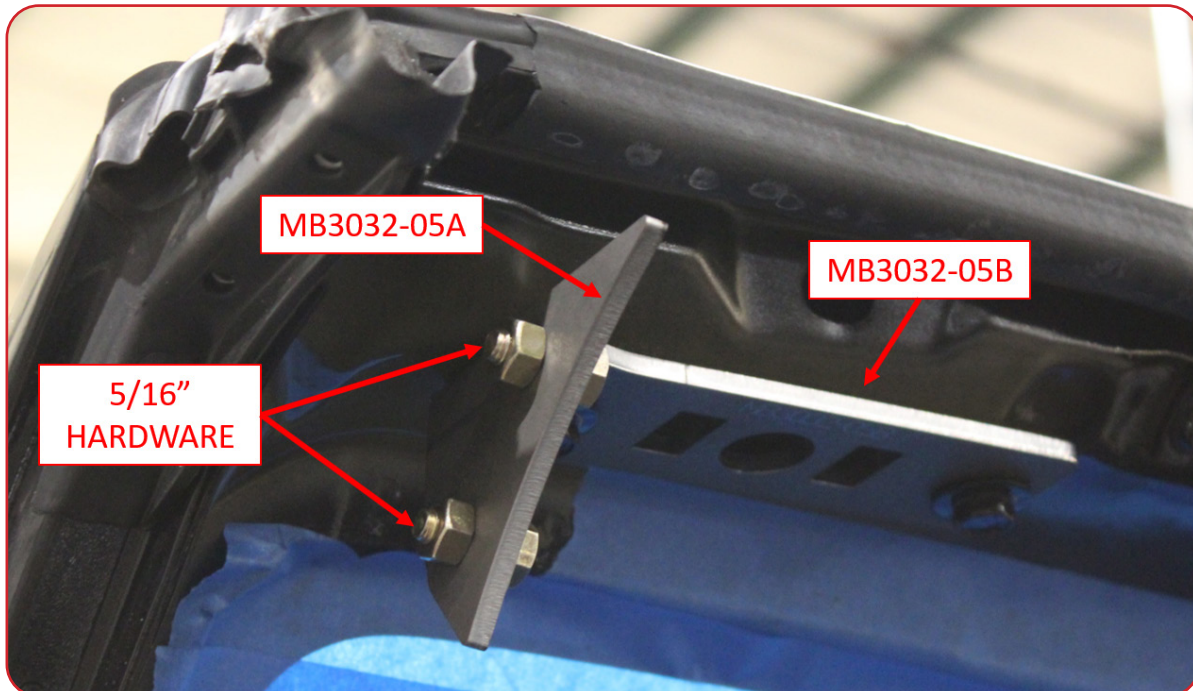

**MB3033 – JKU Cage Knock Down Kit Assembly Instructions**

- 69** Remove the visor clips from the stock roll bar and insert into the square hole on MB3032-05B.





## MB3033 – JKU Cage Knock Down Kit Assembly Instructions

- 70** Place the Driver Side Hoop on MB3033-Tube 08 and the D-pillar roll cage foot and hold in place.

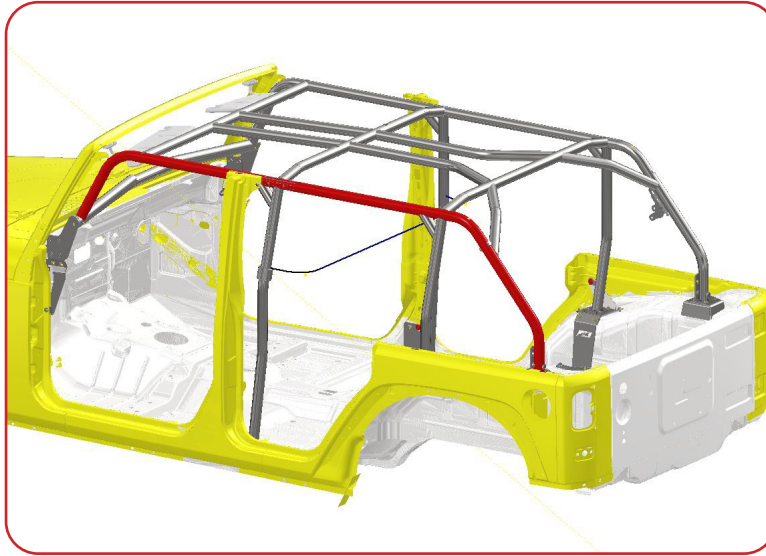

- 71** Place the passenger Side Hoop on MB3033-Tube 08 and the D-pillar roll cage foot and hold in place.

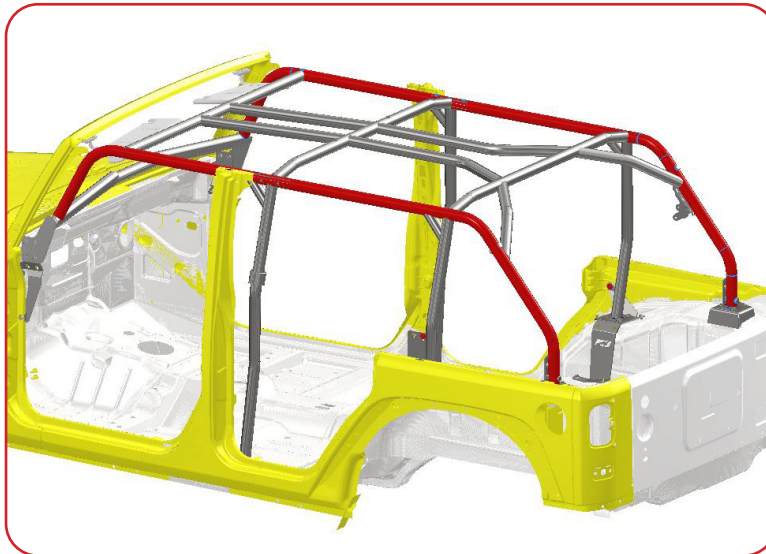

**MB3033 – JKU Cage Knock Down Kit Assembly Instructions**

- 72** Place tube MB3033-Tube 06 at the splice joint between the driver side hoop and passenger side



- 73** Using a strap, hold the tube assembly and check for fitment with the freedom panels. The tube sleeves need to line up with the holes used to secure the freedom panels to the jeep.





**MB3033 – JKU Cage Knock Down Kit Assembly Instructions**

- 74** Install the top and confirm that there are no conflicts and check that the cage is square.



- 75** Tack the driver side hoop and passenger side hoop to MB3033-Tube 08, MB3033-Tube 06, MB3032-05A, and the D-Pillar cage foot (MB3022).

**MB3033 – JKU Cage Knock Down Kit Assembly Instructions**

- 76** Install the driver side and passenger side B-Pillar tubes. Install MB3033-Tube 14 on the driver side. The top of MB3033-Tube 14 should straddle the driver side hoop splice joint and be inline with MB3033-Tube 06. The bottom of MB3033-Tube 14 should land centered on MB3022 B-Pillar cage foot. Tack MB3033-Tube 14 in place. Repeat on passenger side with MB3033-Tube 15.



- 77** Place MB3033-Tube 05 between the driver side hoop and passenger side hoop.

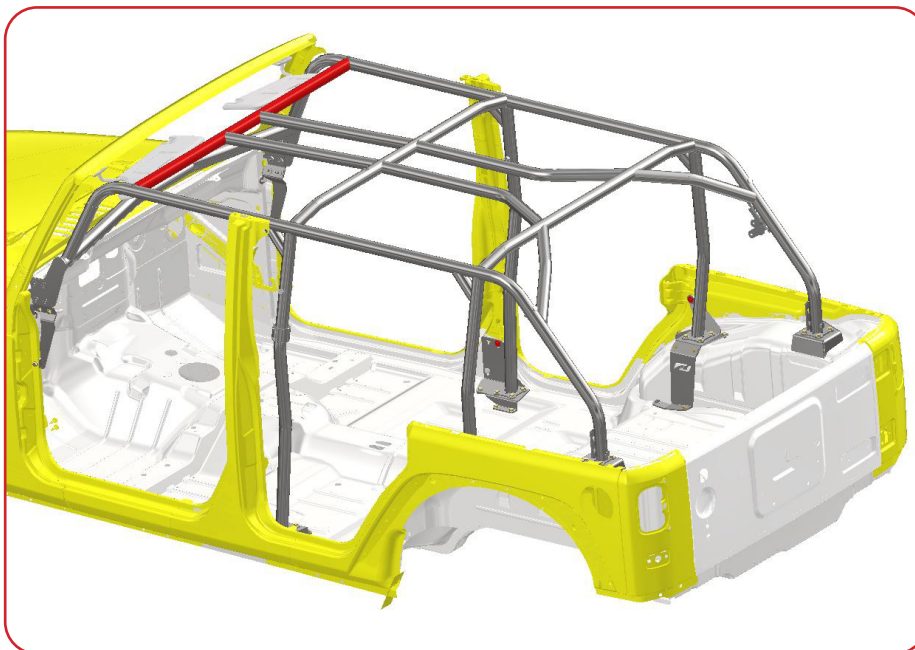

**MB3033 – JKU Cage Knock Down Kit Assembly Instructions**

- 78** Install both MB3033-Tube 09 tubes between MB3033-Tube 06 and MB3033-Tube 05. These tubes will set the place of tube MB3033-Tube 05. The inside dimensions of between the two MB3033-Tube 09 tubes should be 6-3/16". Tack tubes in place.

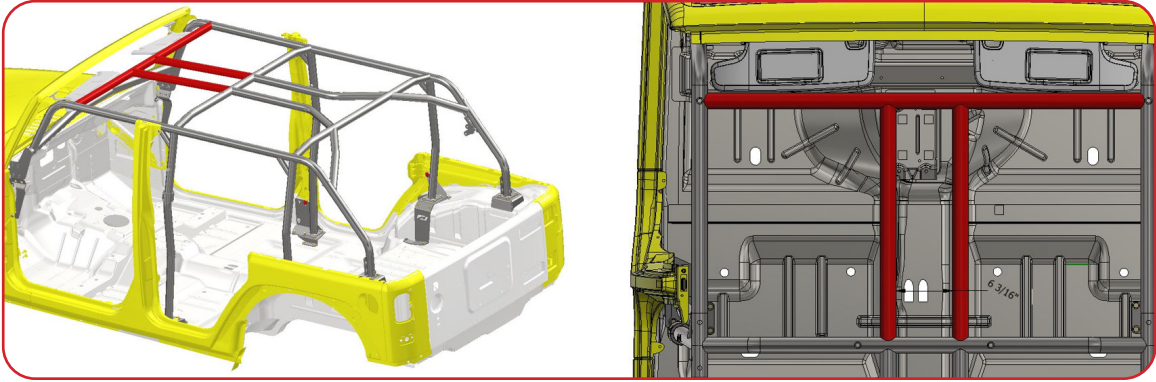

- 79** Install the rear most cross bar MB3033-Tube 07 between the driver side hoop and passenger side hoop.

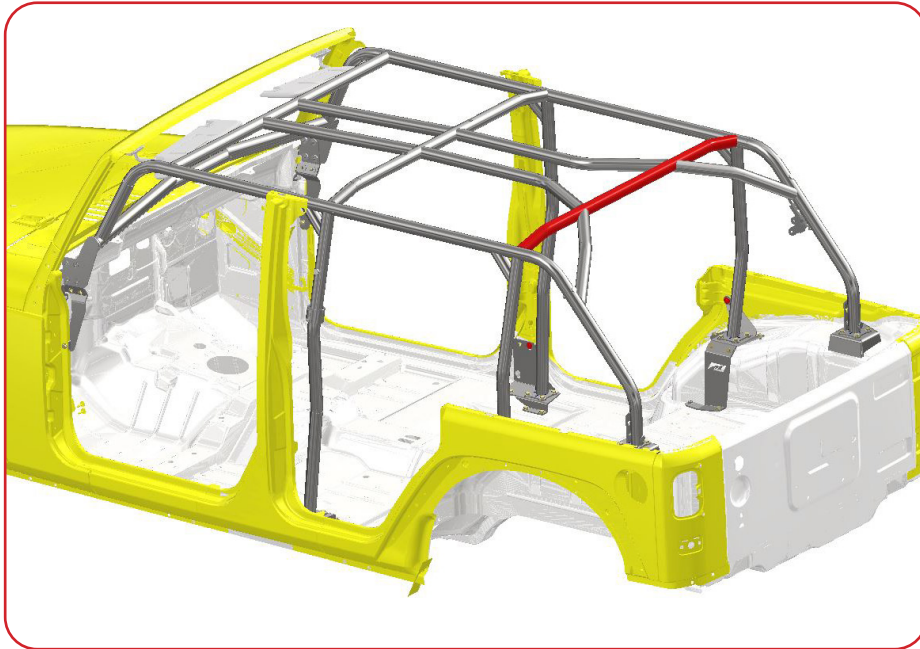



**MB3033 – JKU Cage Knock Down Kit Assembly Instructions**

- 80** Install MB3033-Tube 10 and MB3033-Tube 11 in-between MB3033-Tube 06 and MB3033-Tube 07. The inside distance between MB3033-Tube 10 and MB3033-Tube 11 should be set to 6-3/16". Tack all three tubes in place.

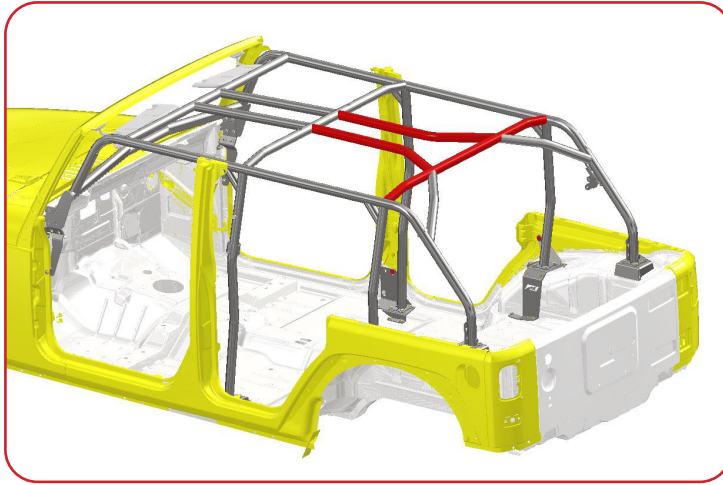

- 81** Install the two C-Pillar bars MB3033-Tube 16 and MB3033-Tube 17. The top of the C-Pillar tubes should be inline with MB3033-Tube 07 and should land on the C-pillar MB3022 cage foot. Tack both tubes in place.

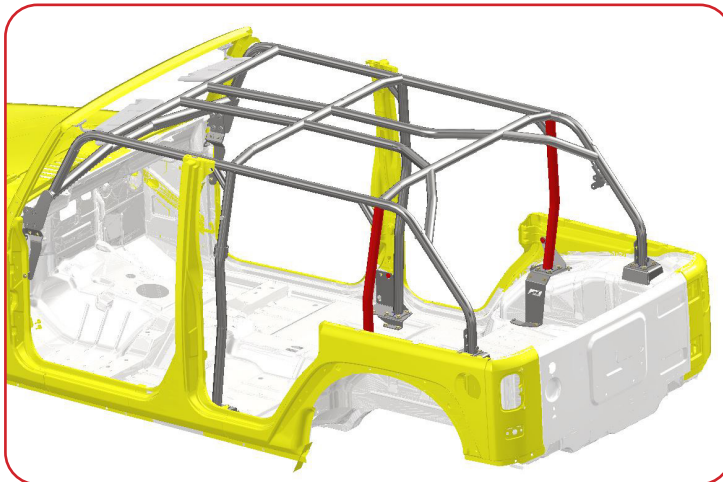

**MB3033 – JKU Cage Knock Down Kit Assembly Instructions**

- 82** Install tube MB3033-Tube 12 and MB3033-Tube 13. Align MB3033-Tube 12 to MB3033-Tube 10 and tack in place to MB3033-Tube 07 and the driver side hoop. Align MB3033-Tube 13 to MB3033-Tube 11 and tack in place to MB3033-Tube 07 and the passenger side hoop.

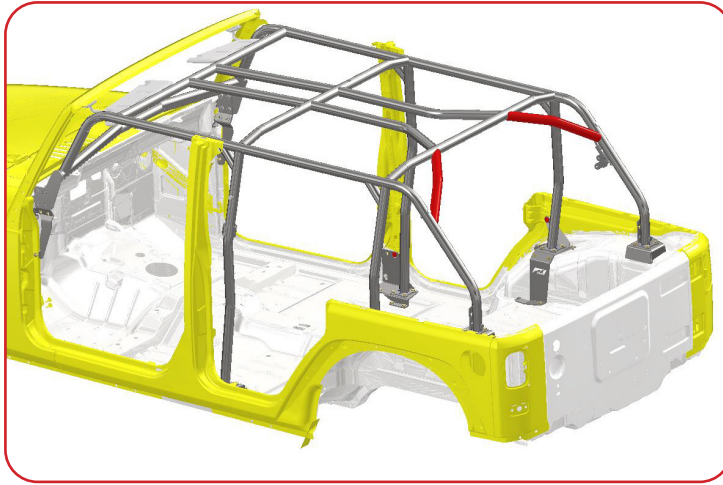

- 83** Tack in place the four gusset tubes MB3033-Tube 19 between the B-Pillar and driver side hoop and passenger side hoop and then the C-Pillar and driver side hoop and passenger side hoop.

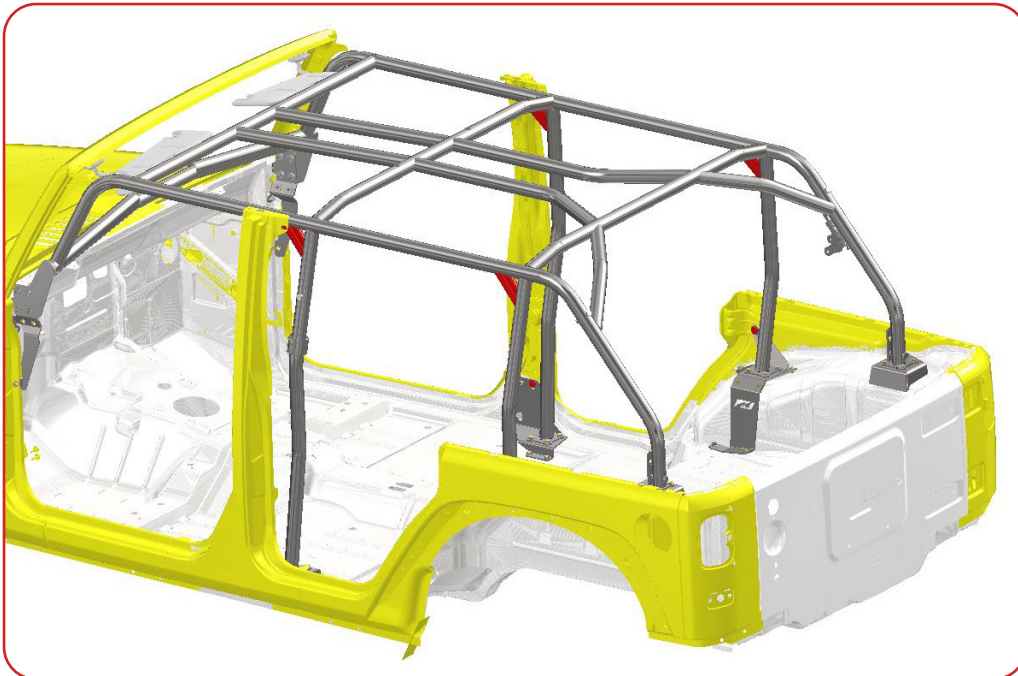

**MB3033 – JKU Cage Knock Down Kit Assembly Instructions**

- 84** Install the B-Pillar Harness bar MB3033-Tube18. The bottom of tube MB3033-Tube18 should measure 27-7/8" from the top of plate MB3022. Tack MB3033-Tube 18 to MB3033-Tube 14 and MB3033-Tube 15 B-pillar bars.

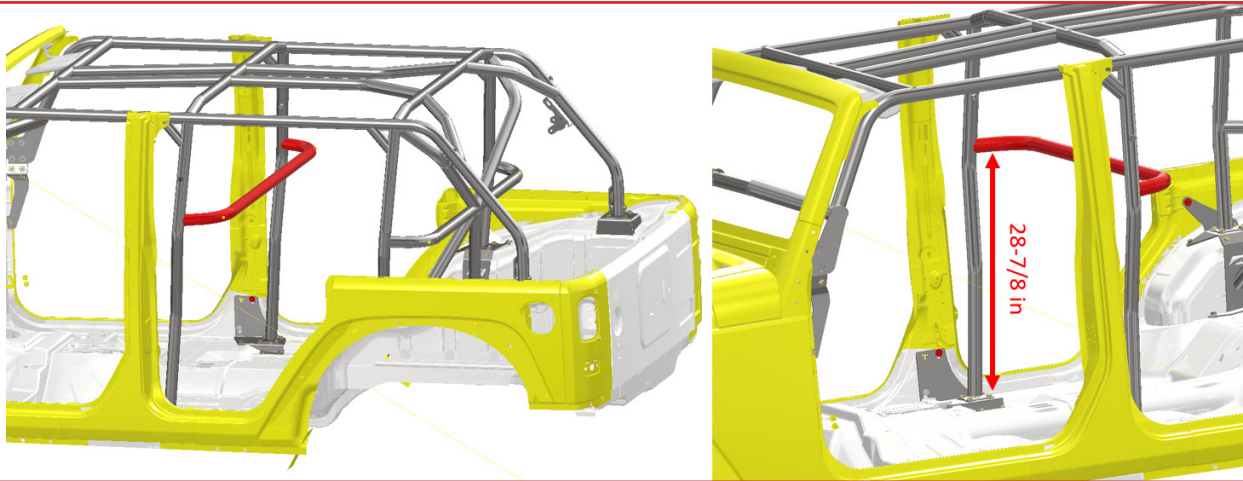

- 85** Install the (optional) MB3033-CH Tube 01 C-Pillar Harness bar on the two c-pillar tubes. Mount the MB3033-CH Tube 01 at the center of the bend in tube MB3033 – Tube 16 and MB3033 – Tube 17. The space between the top of the MB3022 foot pad and bottom of MB3033-CH Tube 01 should be 11in on each side. If being used with the optional C-Pillar X-Bar, we recommend test fitting the top X-Bar tubes before tacking the harness bar in place to confirm fitment.

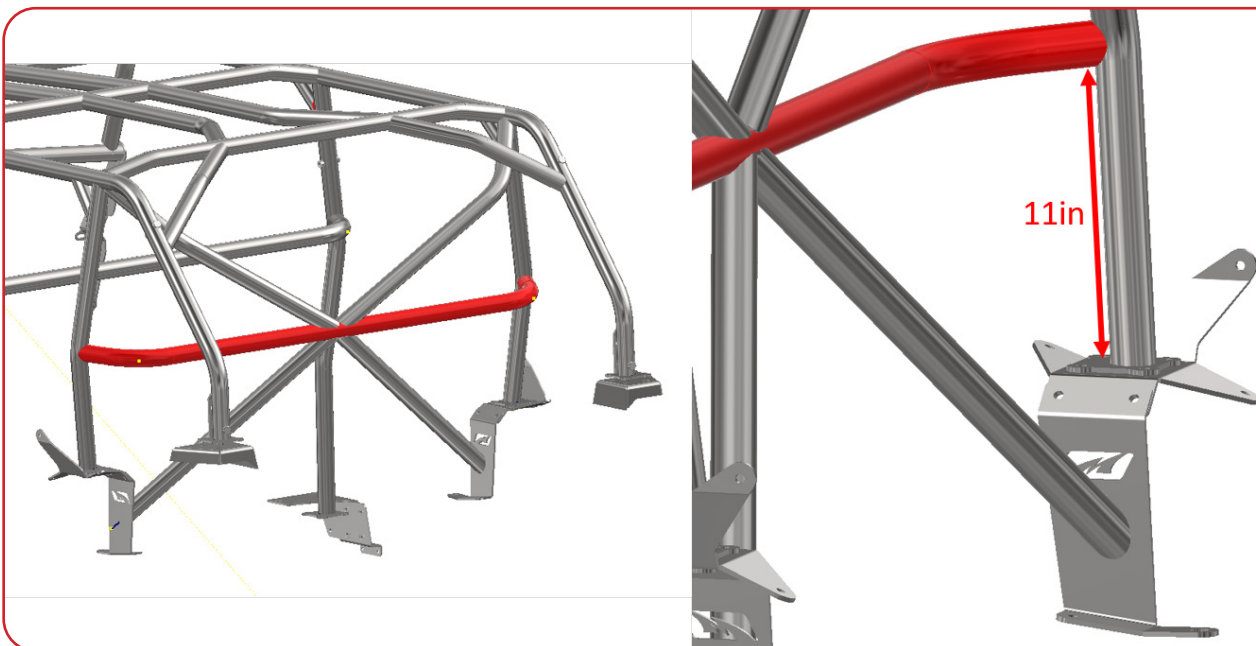

**MB3033 – JKU Cage Knock Down Kit Assembly Instructions**

- 86** Install the (optional) C-Pillar X-bars starting with the top two bars MB3033-CX - Tube 01 and MB3033-CX - Tube 02. Test fit and tack the tubes in place at the center of MB3033-CH – Tube 01 and the top of MB3033 – Tube 16 and MB3033 – Tube 17 C-pillar tubes. The height of the harness bar MB3033-CH – Tube 01 may need to be adjusted to allow for the proper fit.

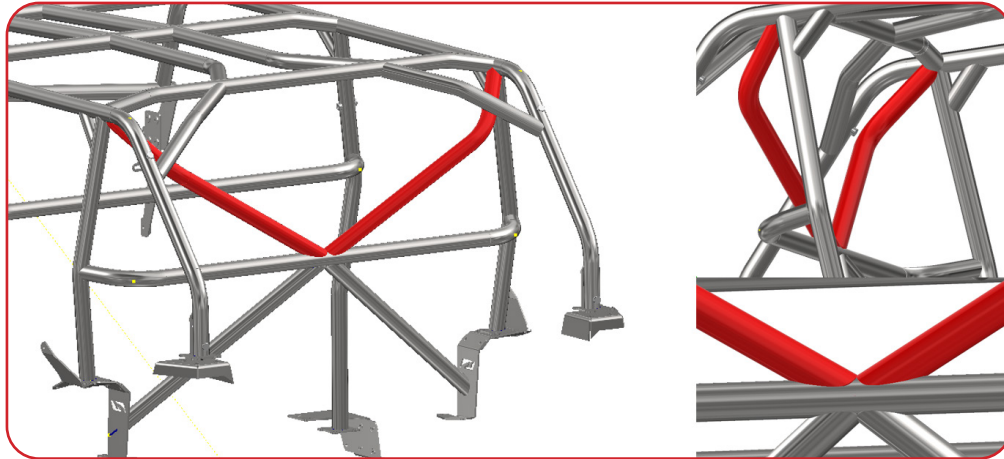

- 87** Mount at the bottom two (optional) X-Bar tubes in place MB3033-CX - Tube 03 and MB3033-CX - Tube 04. The top of the tubes are welded at the center of MB3033-CH – Tube 01 and the bottoms are welded to MB3032-10 and MB3032-10\_MIR.

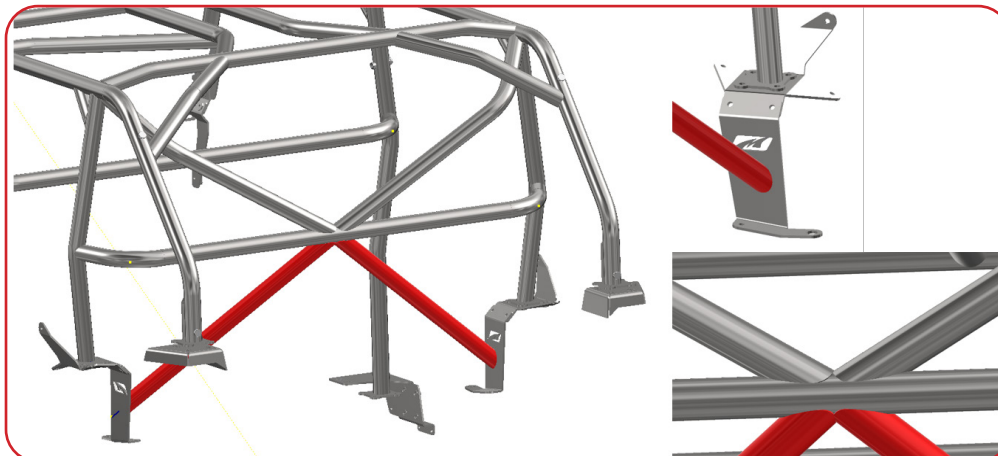



**MB3033 – JKU Cage Knock Down Kit Assembly Instructions**

- 88** Unbolt the cage from the six mounting locations and finish weld the cage. Move around the cage welding opposite corners to prevent the cage from twisting do to uneven heat.



- 89** Install the rear seat belt retractor brackets MB3036. Bolt in place and weld the plate to the tube and D-Pillar cage foot MB3022.



**MB3033 – JKU Cage Knock Down Kit Assembly Instructions**

- 90** Weld two freedom panel foot pads MB3032-12 to tubes MB3033-Tube 09 and MB3033-Tube 06. One on the driver side and one on the passenger side. The top surface of MB3032-12 needs to be  $\frac{1}{4}$ " below the top surface of the tubes. It helps to sandwich a  $\frac{1}{4}$ " spacer to a straight edge and tack in place. Finish weld after confirming fitment.

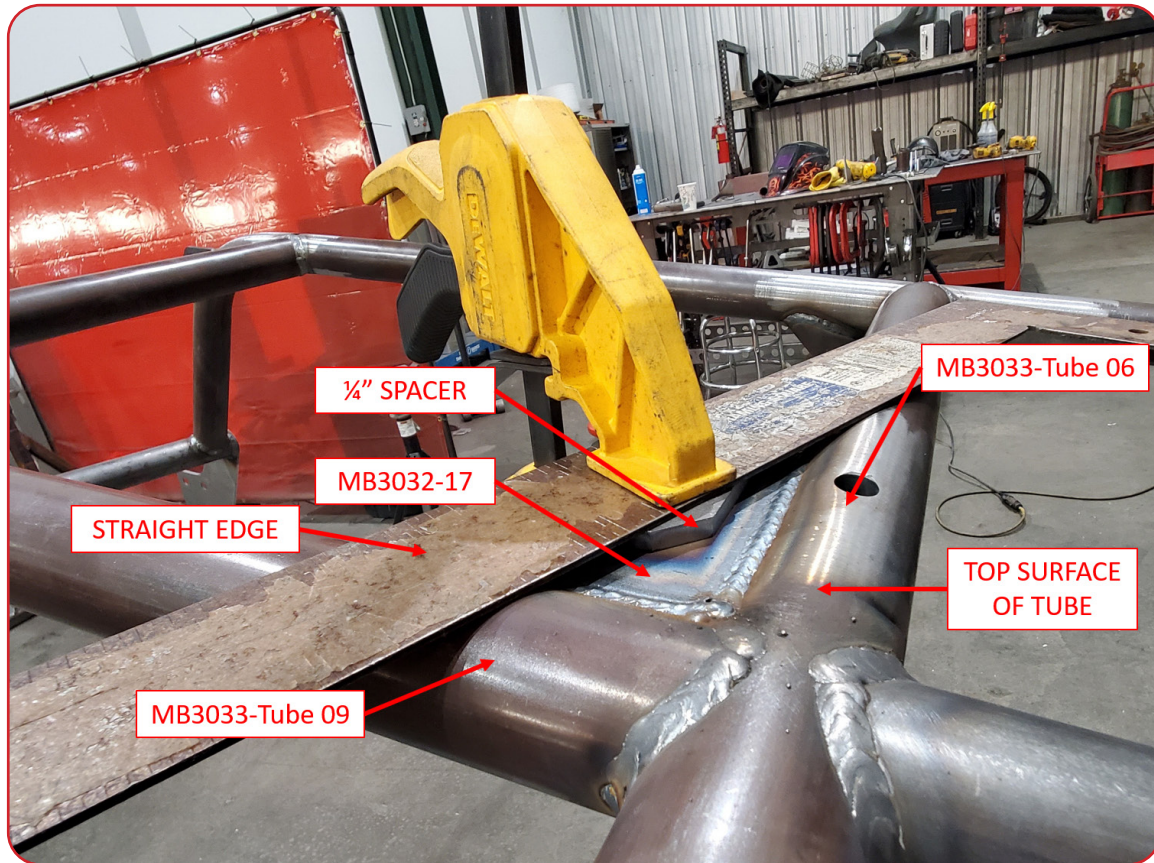

- 91** If equipped weld on the satellite antenna MB3032-13 on the passenger side.



**MB3033 – JKU Cage Knock Down Kit Assembly Instructions**

**92** Weld on grab handles



**Installing the A-Pillar Dash Plate**

**93** Cut off the top retainer clip



**MB3033 – JKU Cage Knock Down Kit Assembly Instructions**

- 94** Trim the dash side panel to remove the center inset.



- 95** Sand down the internal plastic ribbing so it does not interfere with the A-pillar plate



**MB3033 – JKU Cage Knock Down Kit Assembly Instructions**

- 96** Lay the MB3032-15 cover plate over the panel and mark and drill the holes for the rivets. Test fit all the holes line up on the MB3032-14, MB3032-15, and dash trim plate. This may require slightly bending the cover plates by hand to conform to the trim plate. Then remove for paint or powder coating.



- 97** After paint, rivet the MB3032-14 and MB3032-15 cover plates onto the plastic trim panel. Use eight 1/8" rivets on each side with a washer on the plastic side in the back.
- 98** Reinstall the cover plate onto the dashboard.
- 99** Paint roll cage and any unpainted plates.
- 100** Reinstall roll cage.
- 101** Reinstall interior.