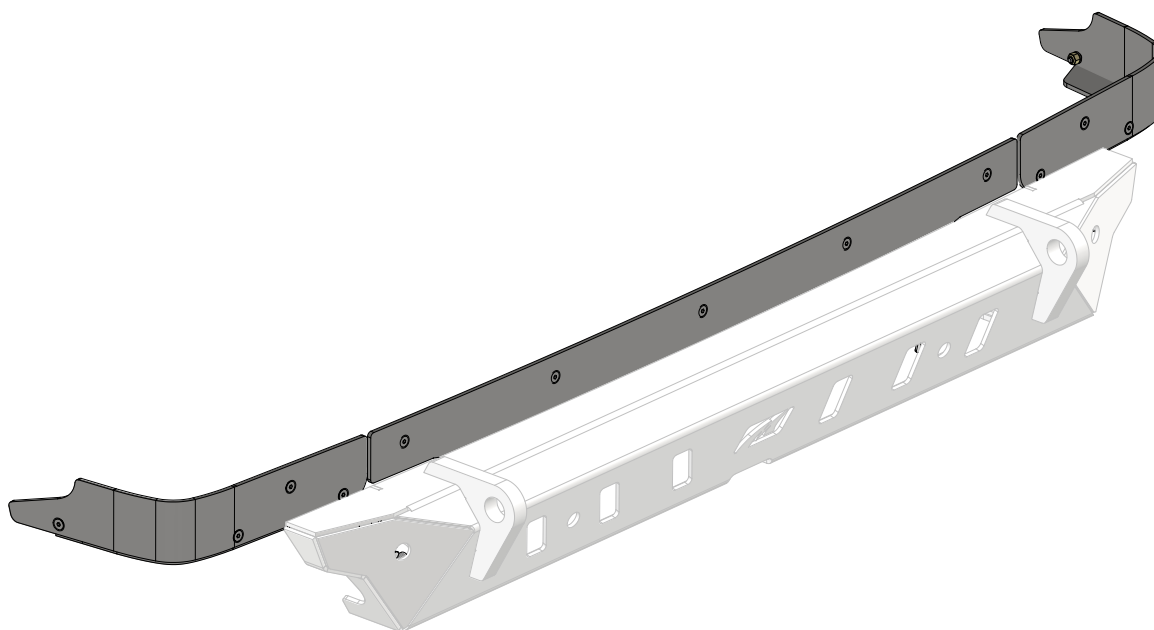

MB2184 - Assembly Instructions JL/JLU Lower Corner Armor

MB2184 - LOWER CORNER ARMOR

COMPATIBLE WITH JEEP JL/JLU

ASSEMBLY INSTRUCTIONS

MB2184 - Shipping JL / JLU Lower Corner Armor

CONTENTS

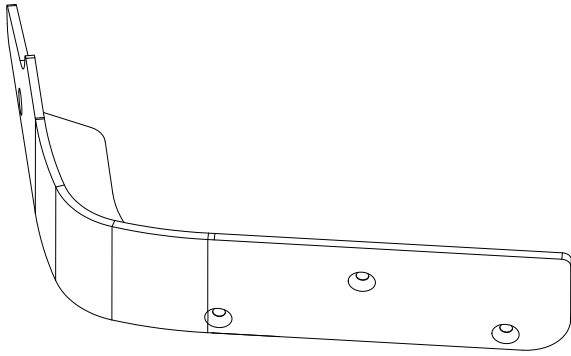
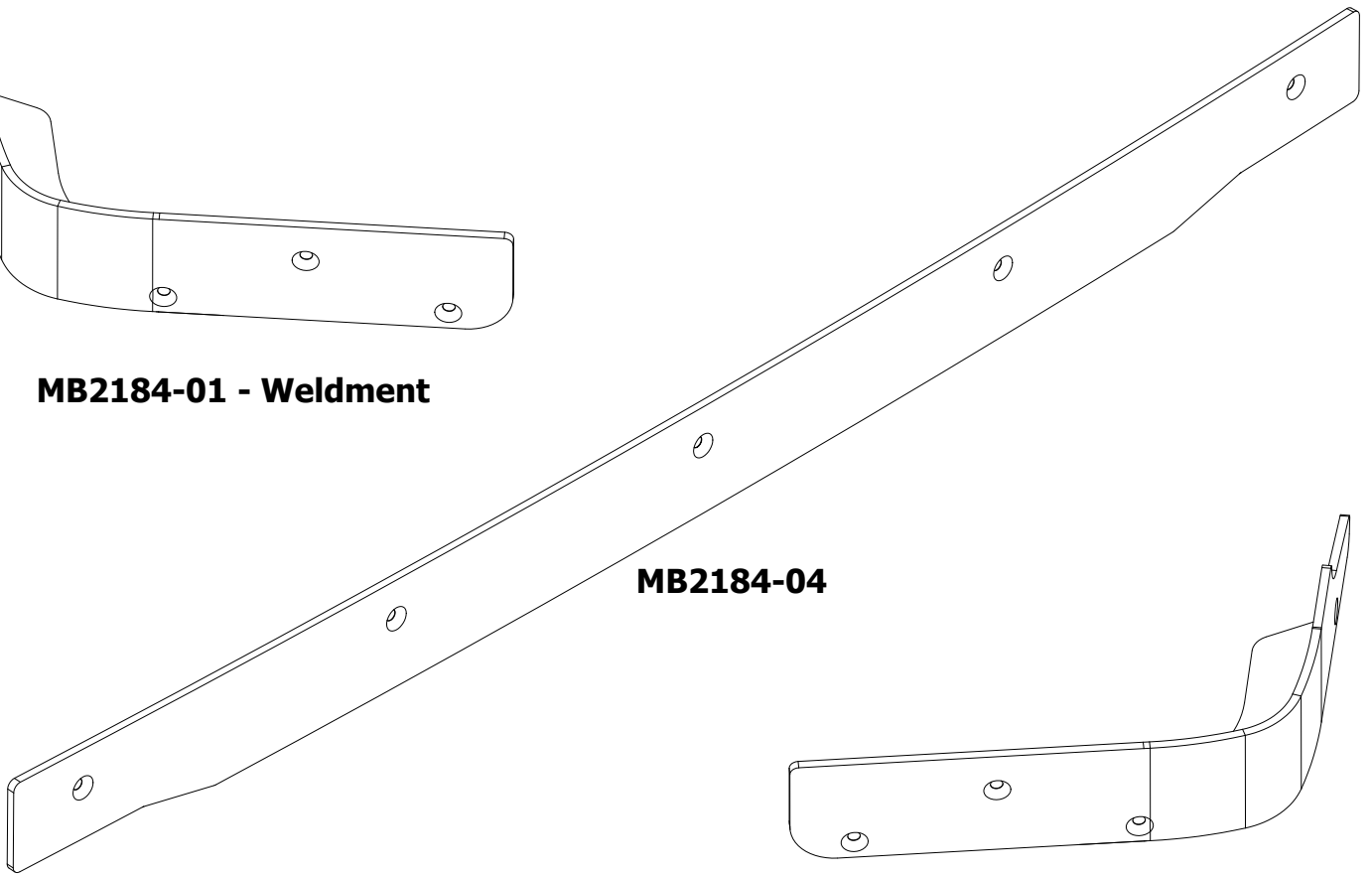
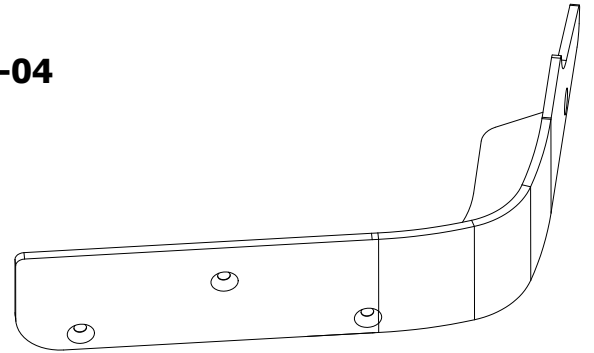
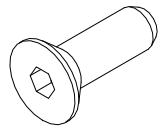
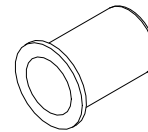
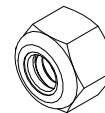
**MB2184-01 - Weldment****MB2184-04****MB2184-03 - Weldment****1/4\"-20 x .75\" Flat Socket Cap Screw
Qty 15
(Includes 2 Spare)****Rivnut 1/4\" UNC
Qty 9
(Includes 2 Spare)****1/4\" Flat Washer
Qty 6****1/4\"-20 Nylon Locknut
Qty 6**

MB2184 - Assembly Instructions JL/JLU Lower Corner Armor**Step 01**

CLAMP MB2184-04 IN PLACE AND MARK HOLES. START IN CENTER AND WORK OUTWARDS. DRILL 1/8" PILOT HOLE BEFORE DRILLING FINAL SIZE.

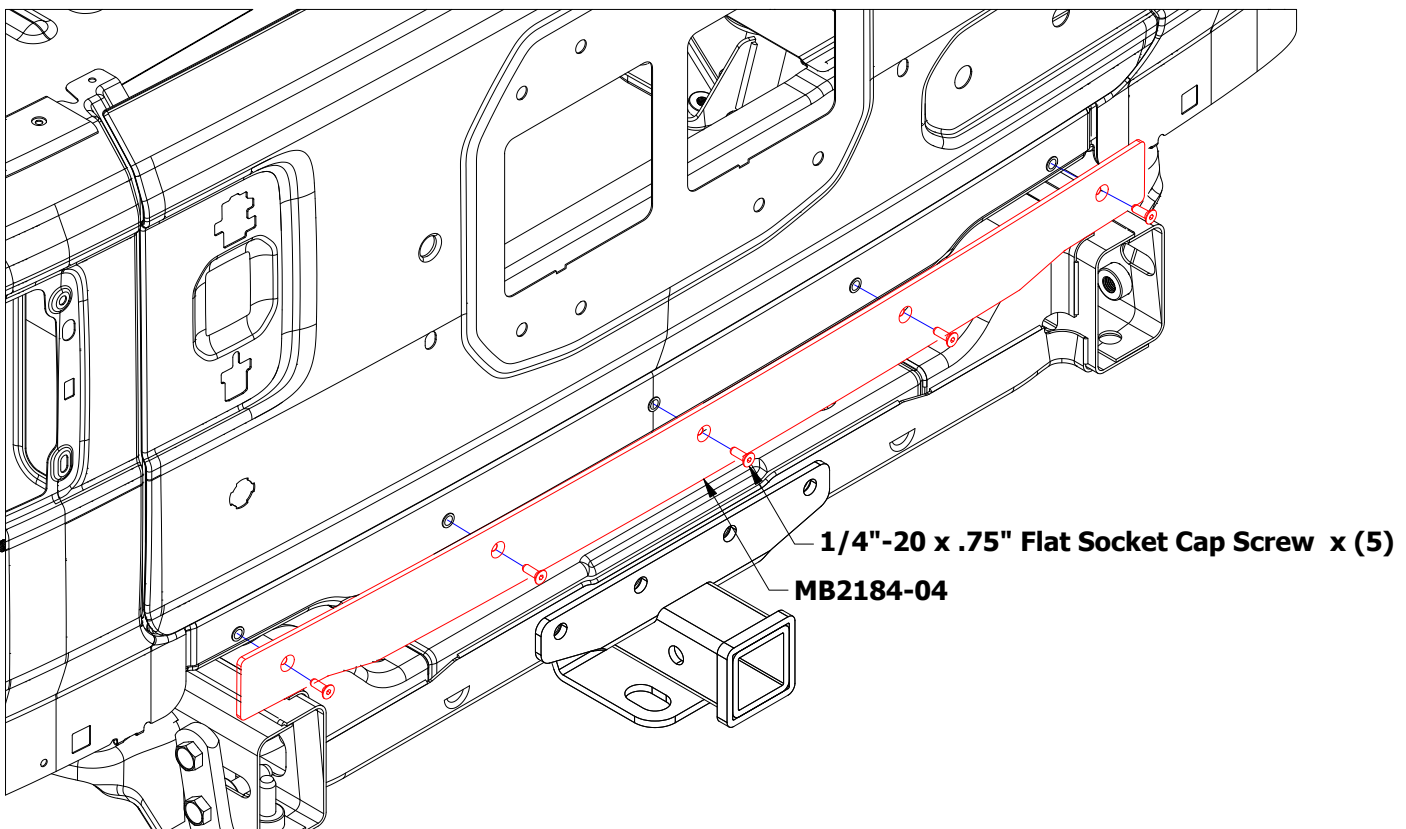
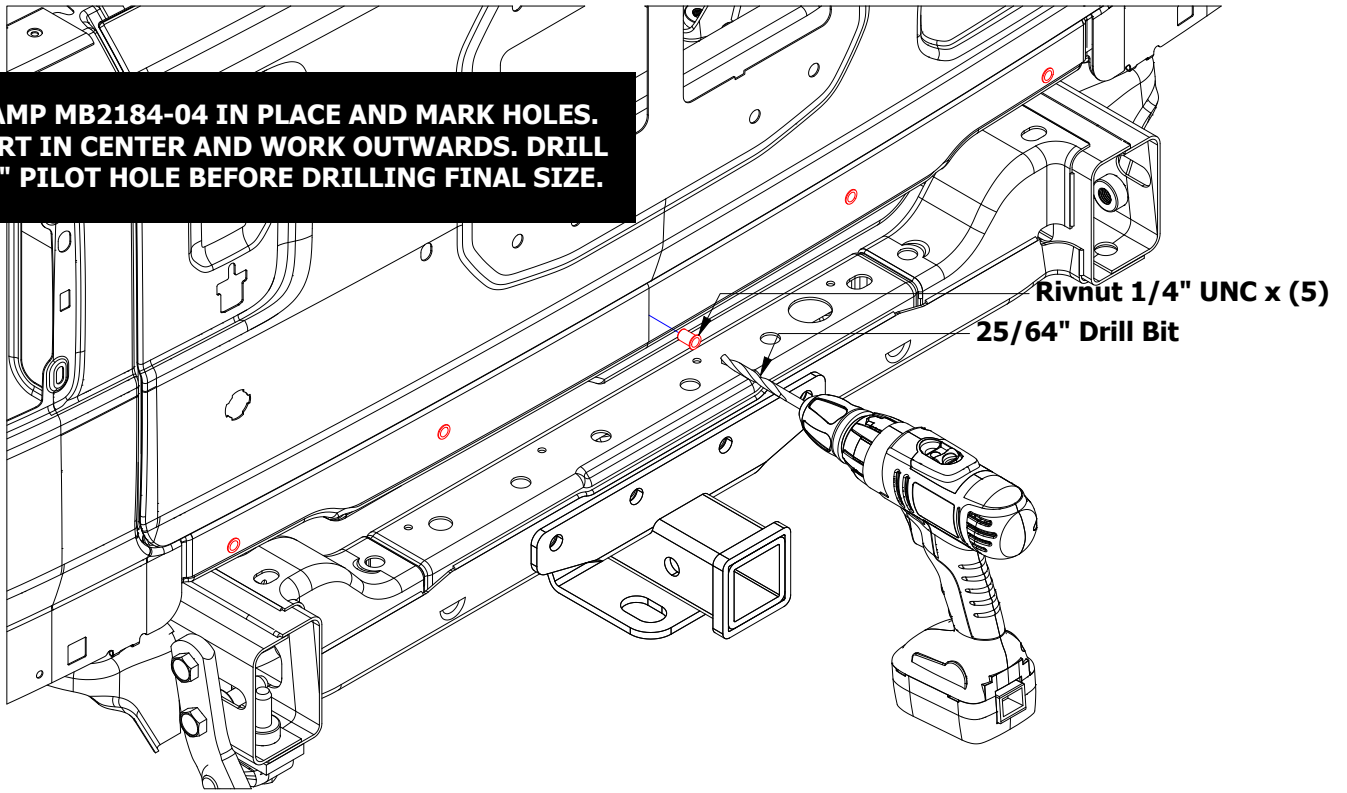

MB2184 - Assembly Instructions JL/JLU Lower Corner Armor**Step 02**

MARK HOLES AND REMOVE CORNER ARMOR. DRILL 1/8" PILOT HOLE BEFORE DRILLING FINAL SIZE.

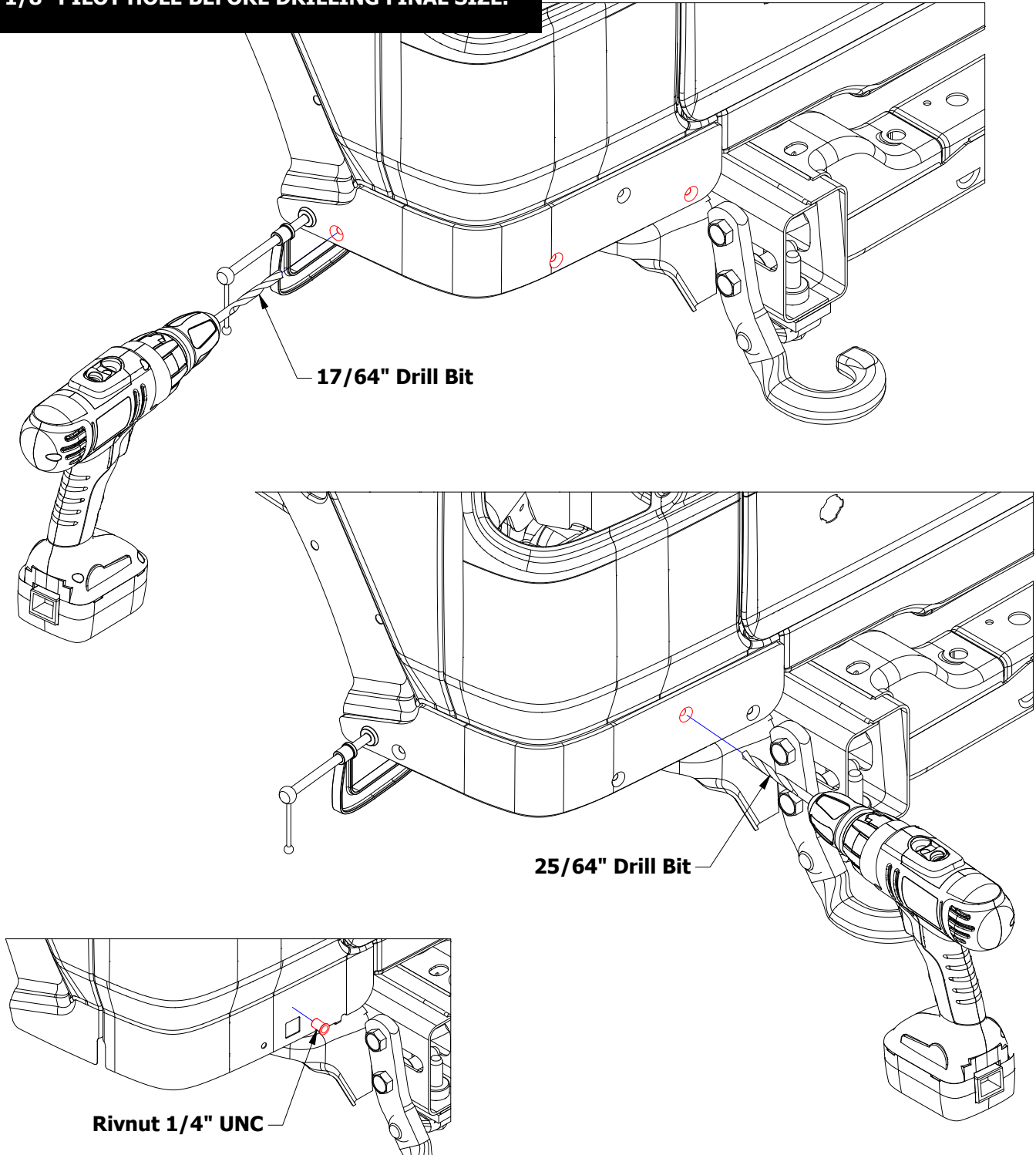

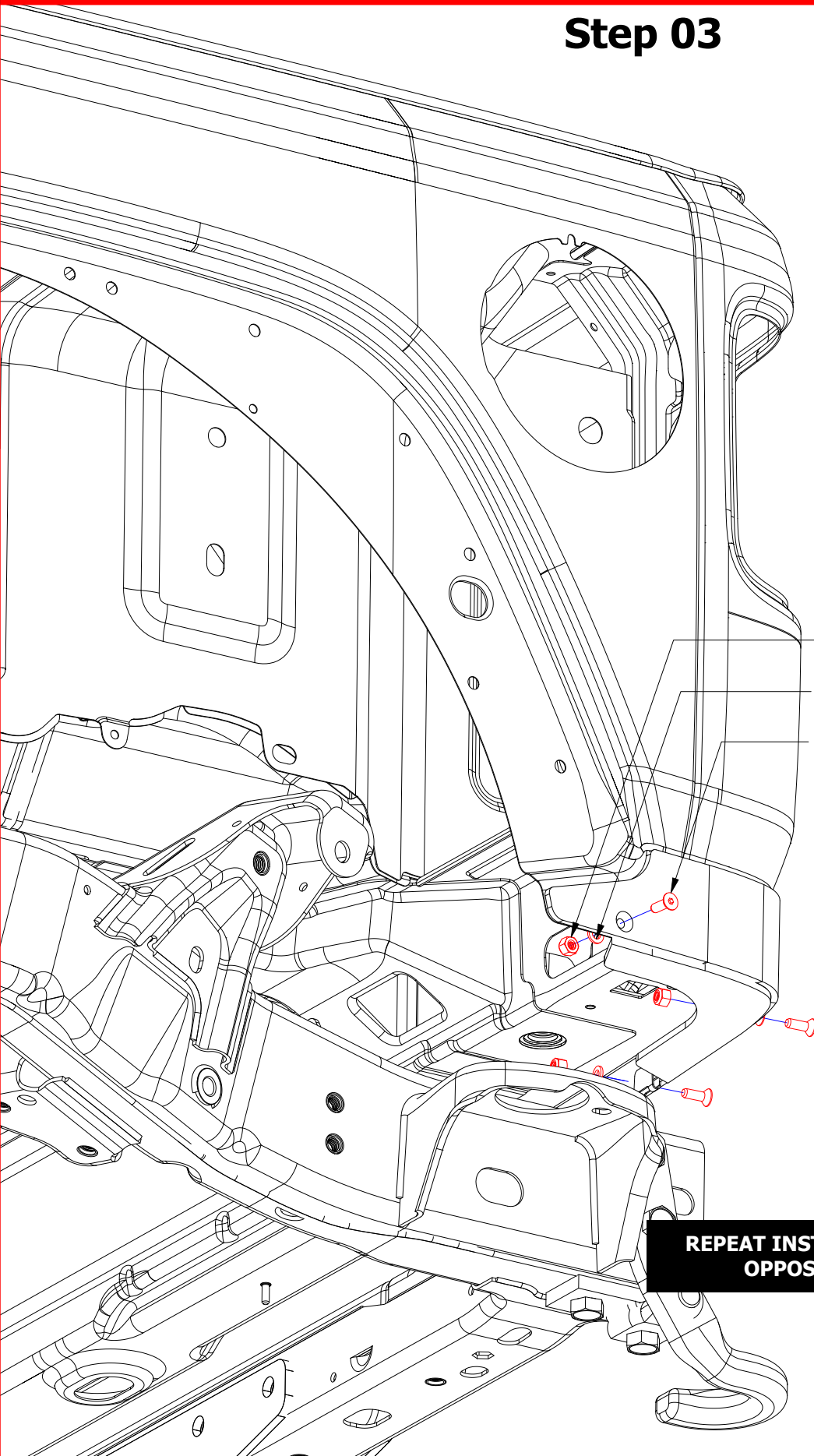
MB2184 - Assembly Instructions JL/JLU Lower Corner Armor**Step 03**

1/4"-20 Nylon Locknut x (3)

1/4" Flat Washer x (3)

1/4"-20 x .75" Flat Socket Cap Screw x (3)

**REPEAT INSTALLATION ON
OPPOSITE SIDE**