

REAR UPPER SHOCK MOUNTS - JL/JLU

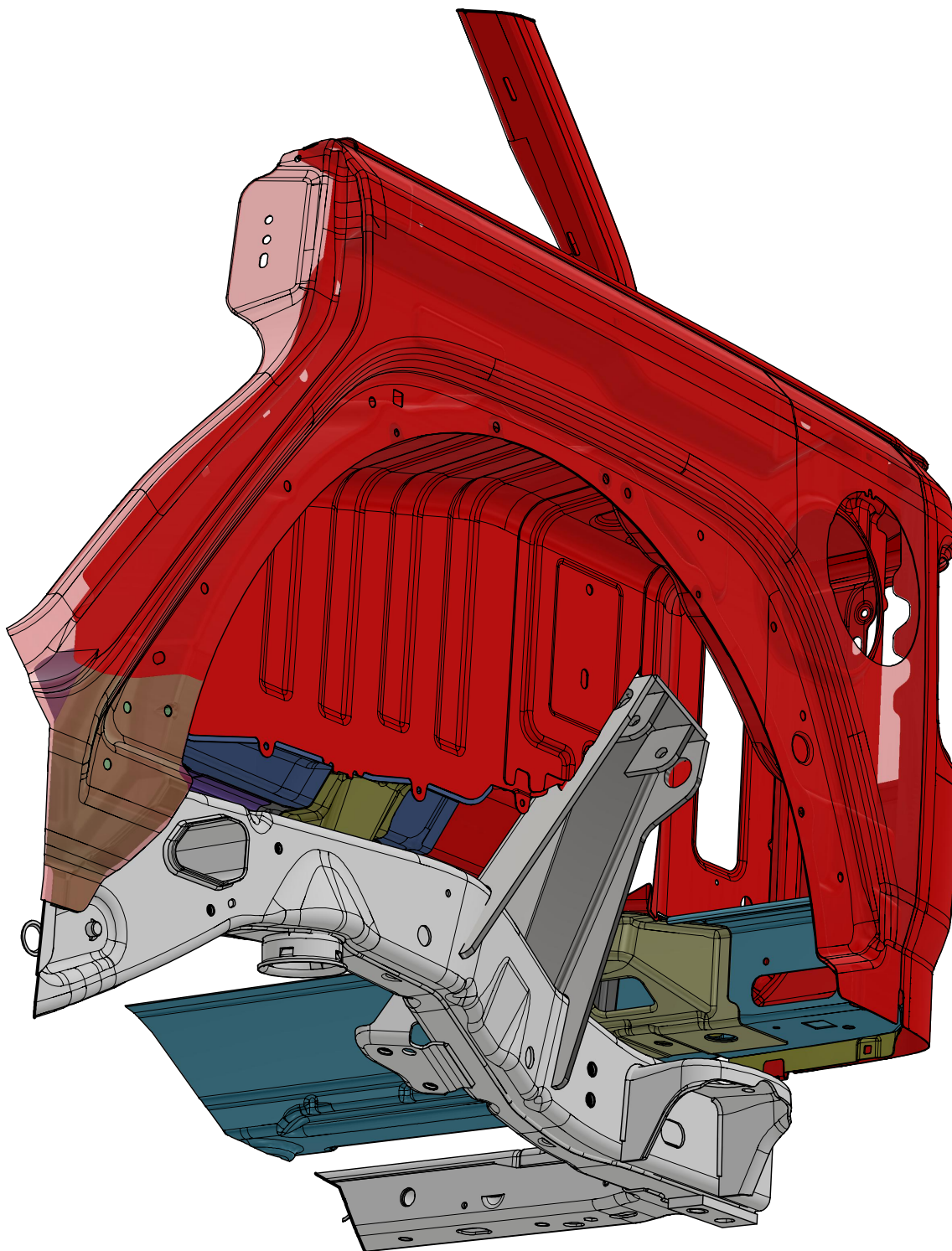

ASSEMBLY INSTRUCTIONS

MB1562 - Assembly Instructions Rear Upper Shock Mounts - JL/JLU

KIT COMPONENTS

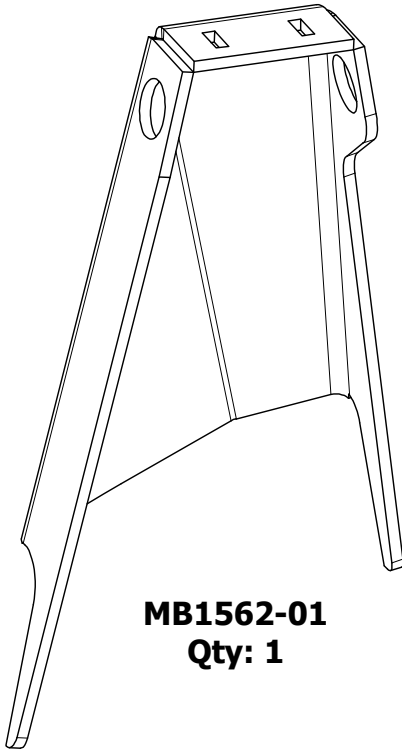

MB1562-01
Qty: 1

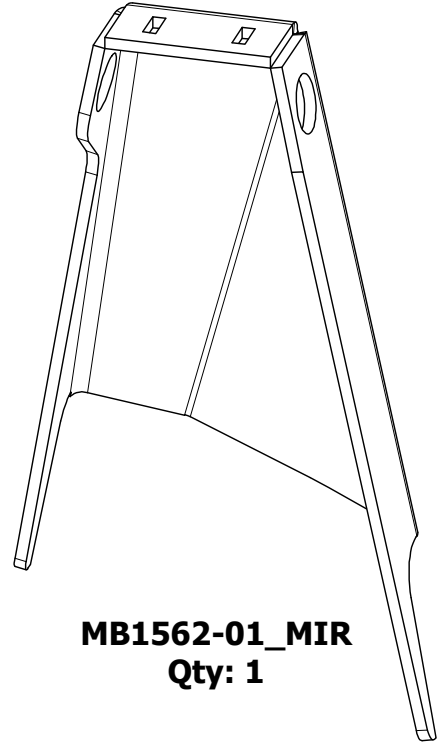

MB1562-01_MIR
Qty: 1

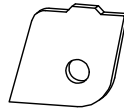

MB1562-02
Qty: 4

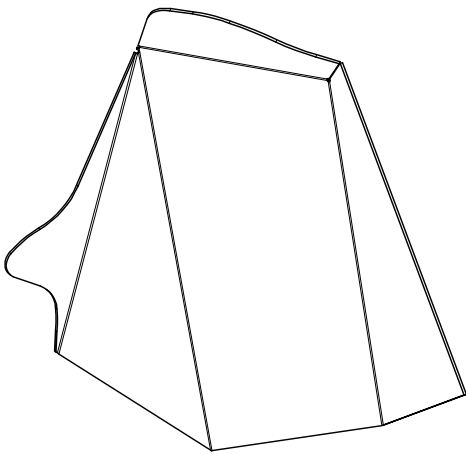

MB1562-03
Qty: 1

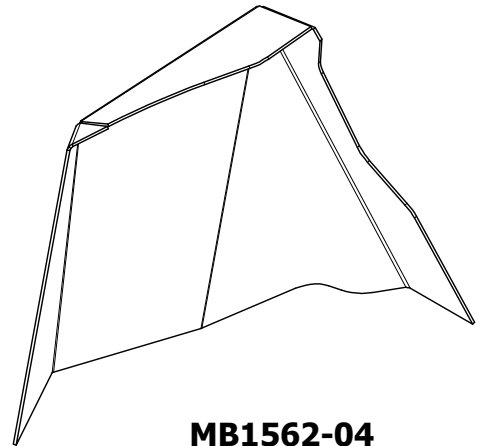

MB1562-04
Qty: 1

MB1562 - Assembly Instructions Rear Upper Shock Mounts - JL/JLU

LOCATOR

CUT OUT THE TEMPLATES AND USE THEM TO LOCATE THE SHOCK TOWER ON THE FRAME

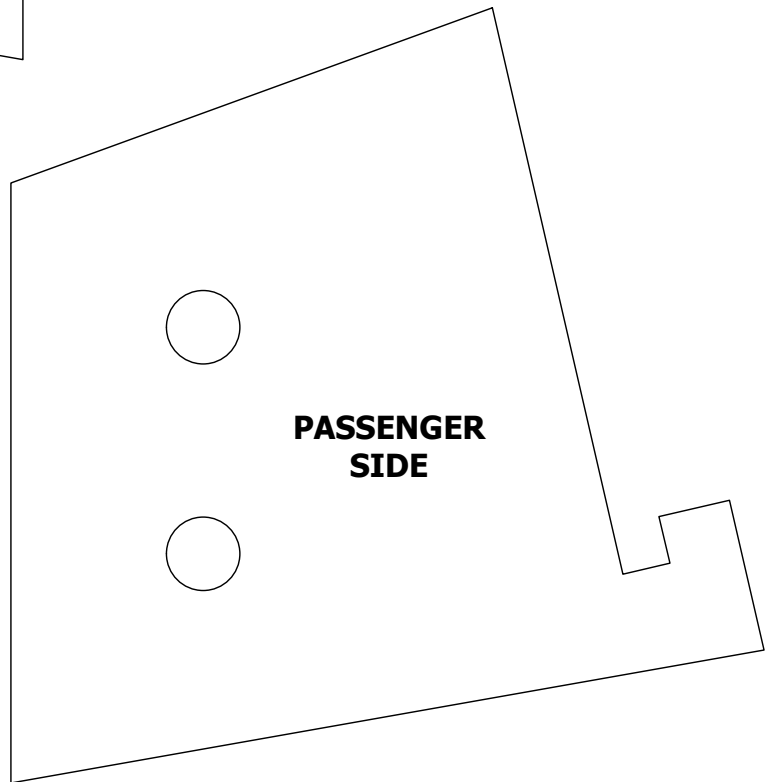
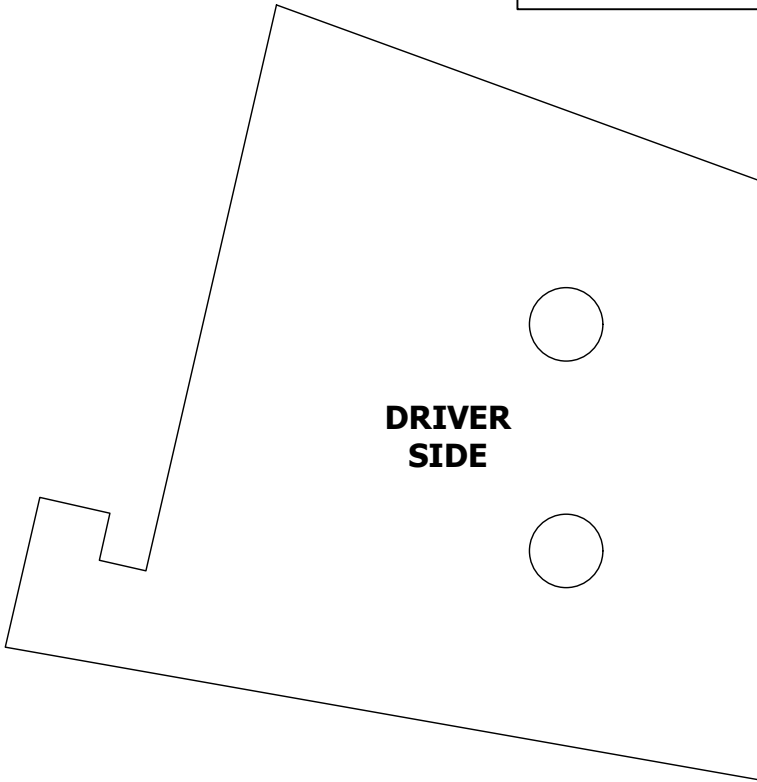

MB1562 - Assembly Instructions Rear Upper Shock Mounts - JL/JLU

BRACKET REMOVAL

BEFORE

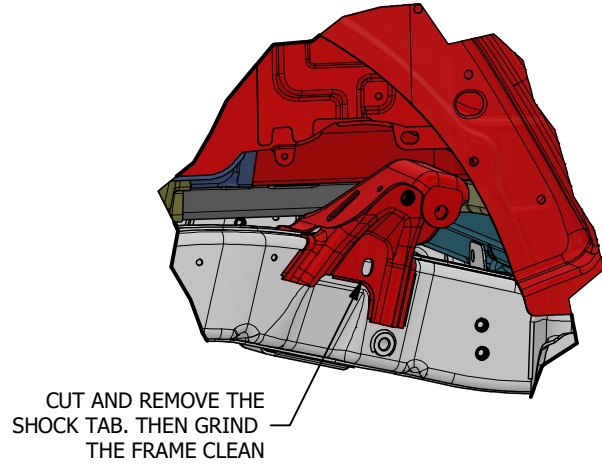
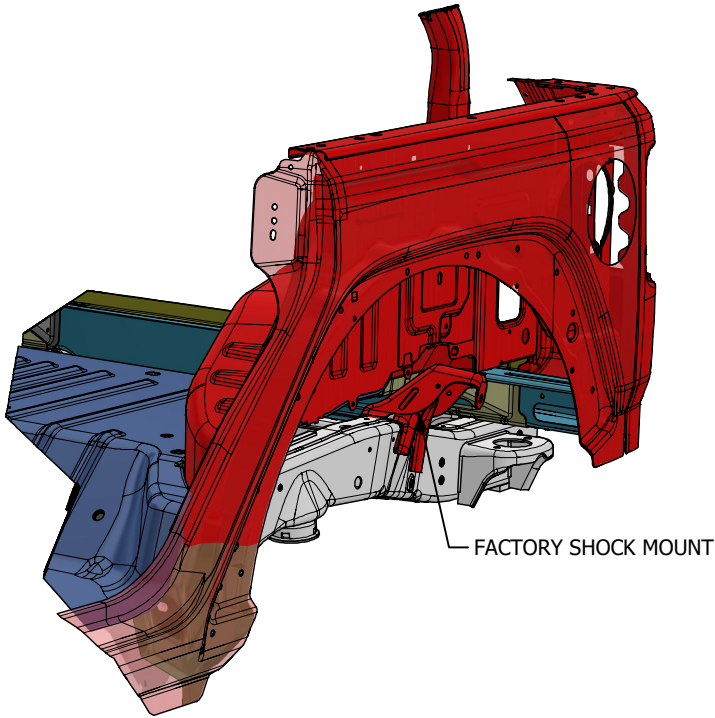

AFTER

DRIVER SIDE SHOWN. REPEAT STEP ON PASSENGER SIDE

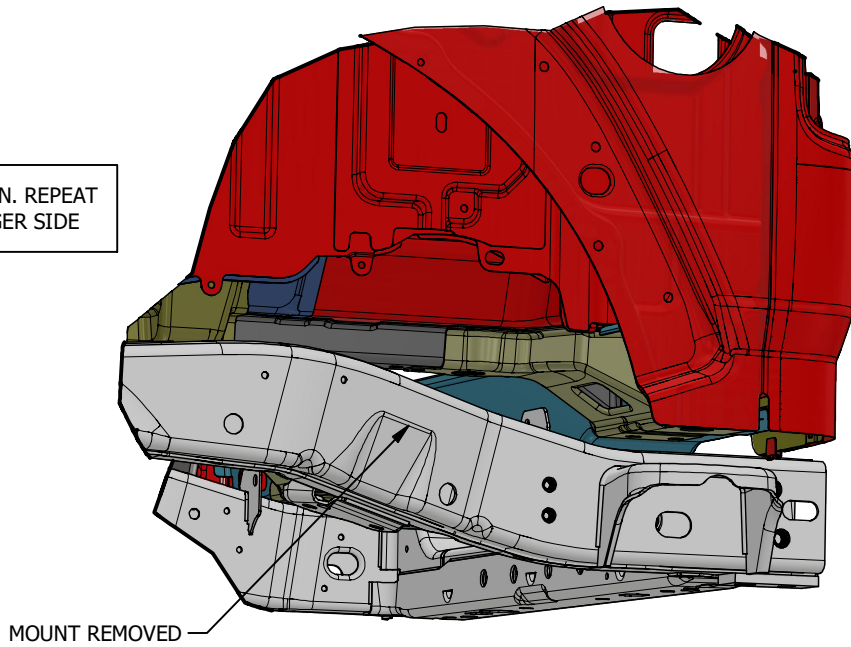

MB1562 - Assembly Instructions Rear Upper Shock Mounts - JL/JLU

INSTALLATION

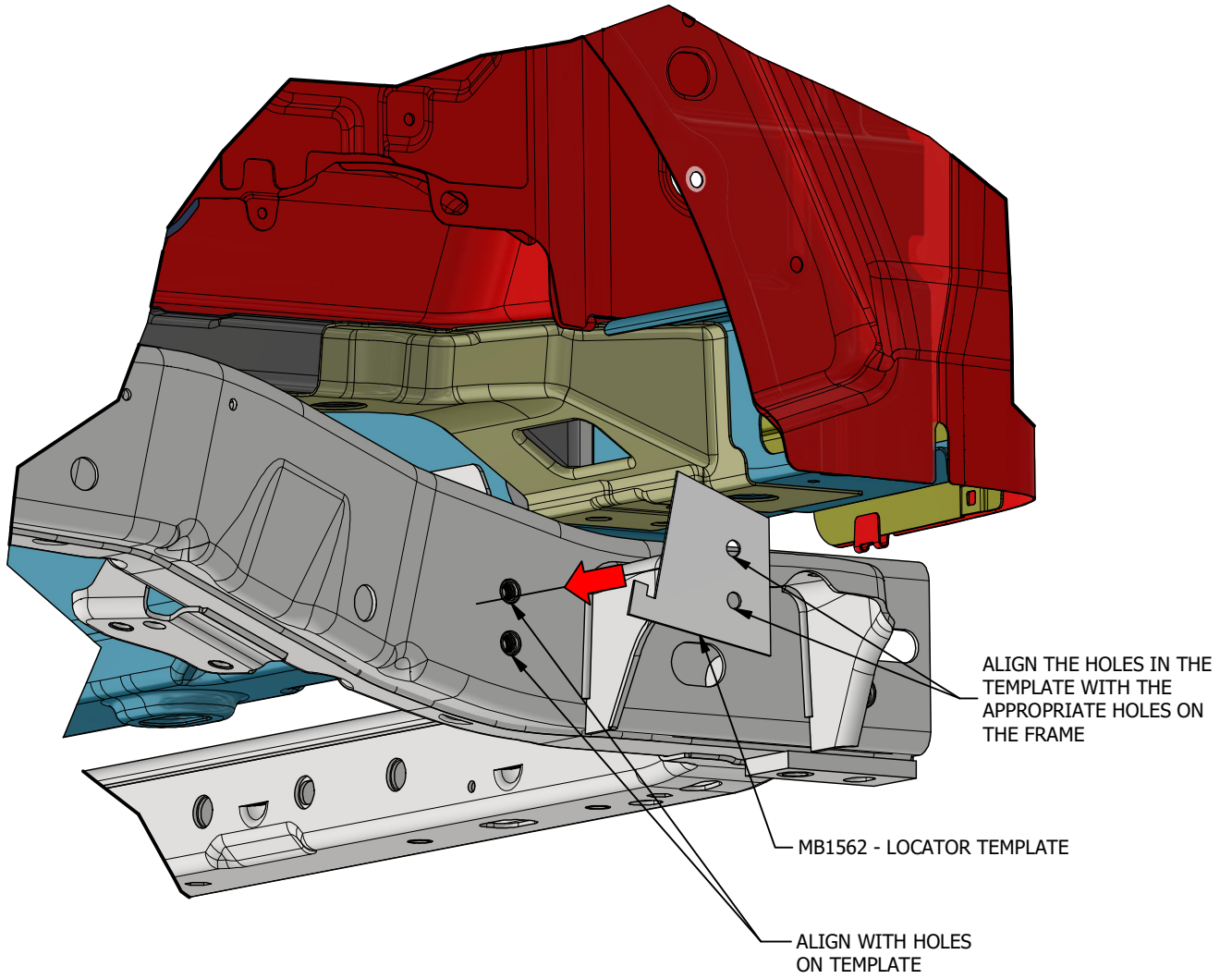

MB1562 - Assembly Instructions Rear Upper Shock Mounts - JL/JLU

TRIMMING THE BODY

MOCK MB1562-01 INTO PLACE AND TRACE AROUND THE TOWER ON THE BODY TO SEE WHERE IT NEEDS TO BE TRIMMED

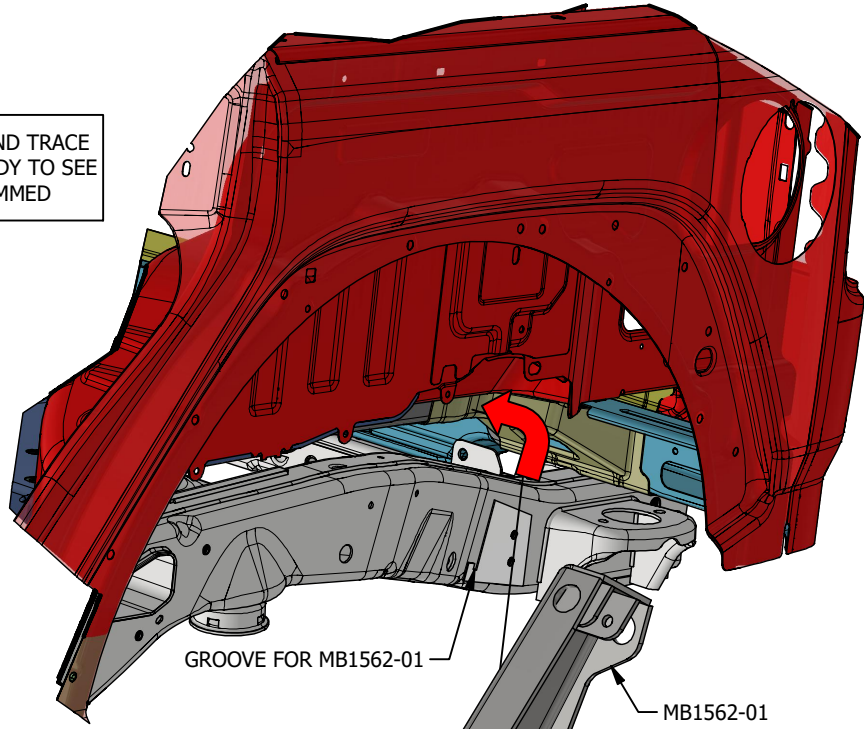

INSERT THIS LEG INTO THE TEMPLATE

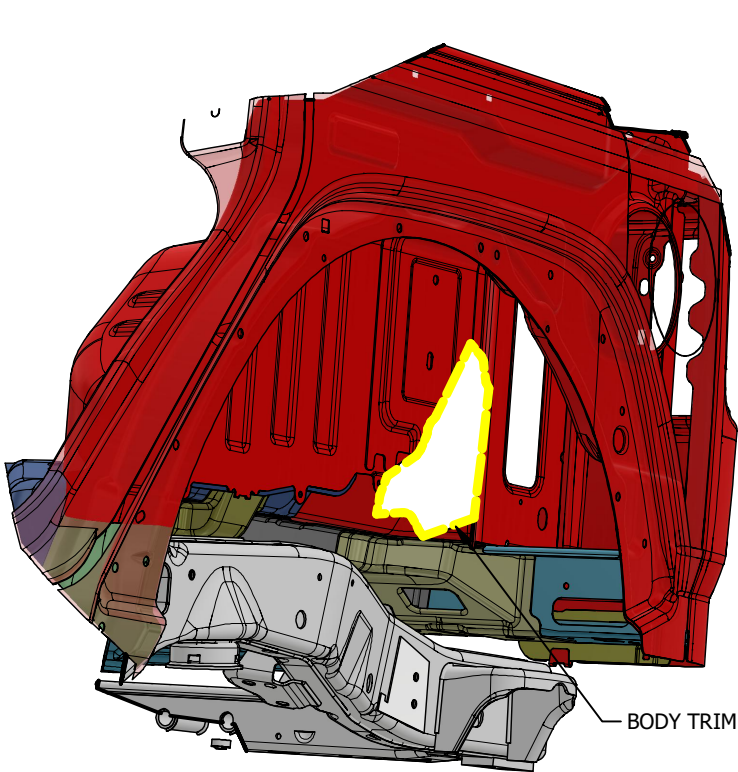

BODY TRIMMED

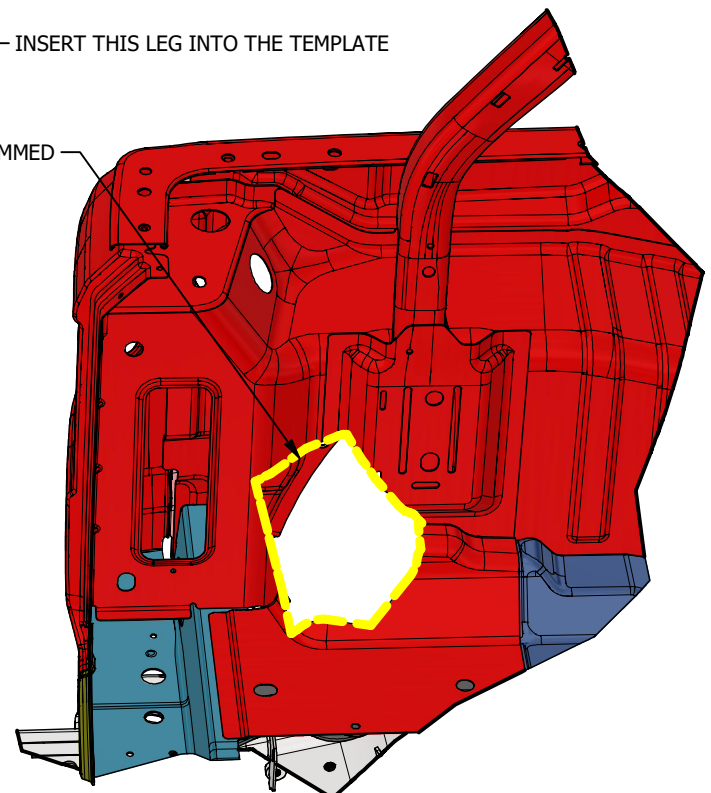

MB1562 - Assembly Instructions Rear Upper Shock Mounts - JL/JLU

TOWER WELD

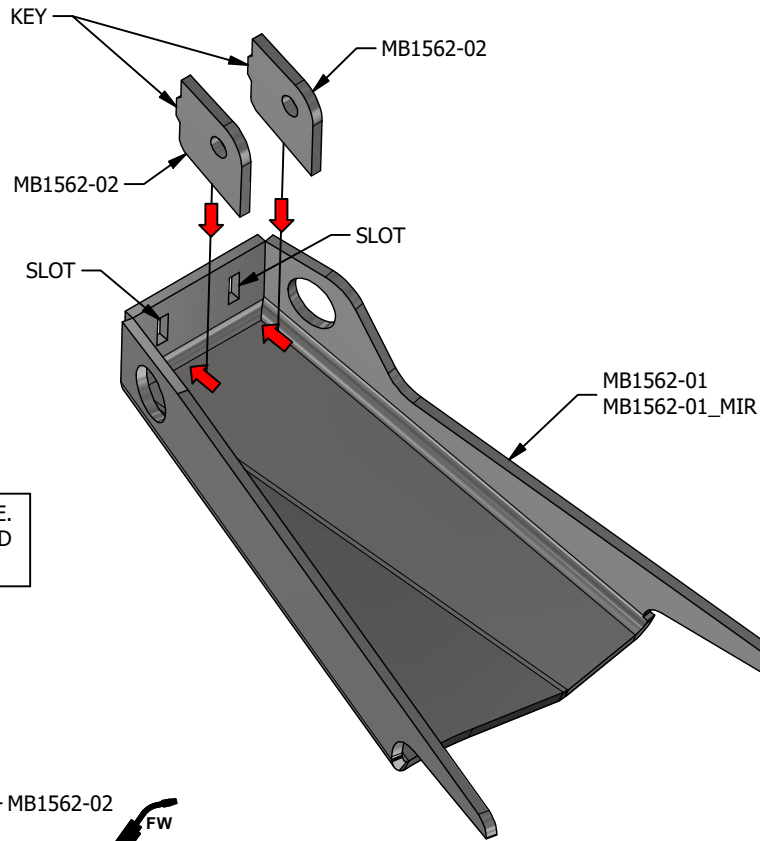

PERFORM THIS STEP TWICE.
ONCE WITH MB1562-01 AND
MB1562-01_MIR

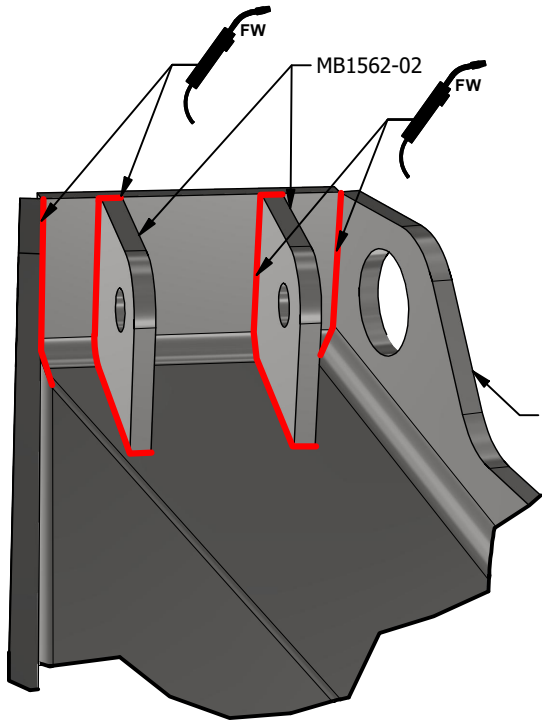

WELD AREAS
HIGHLIGHTED IN RED

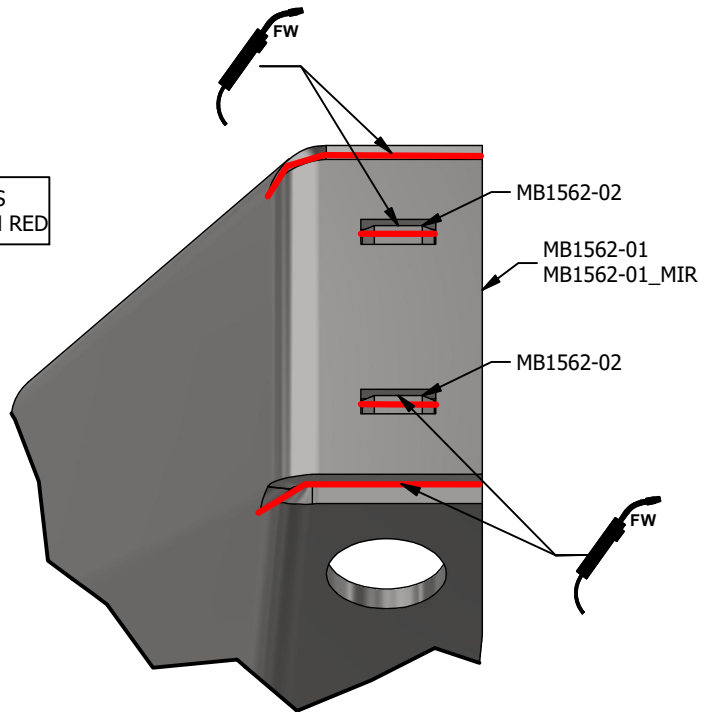

MB1562 - Assembly Instructions Rear Upper Shock Mounts - JL/JLU

TOWER WELD

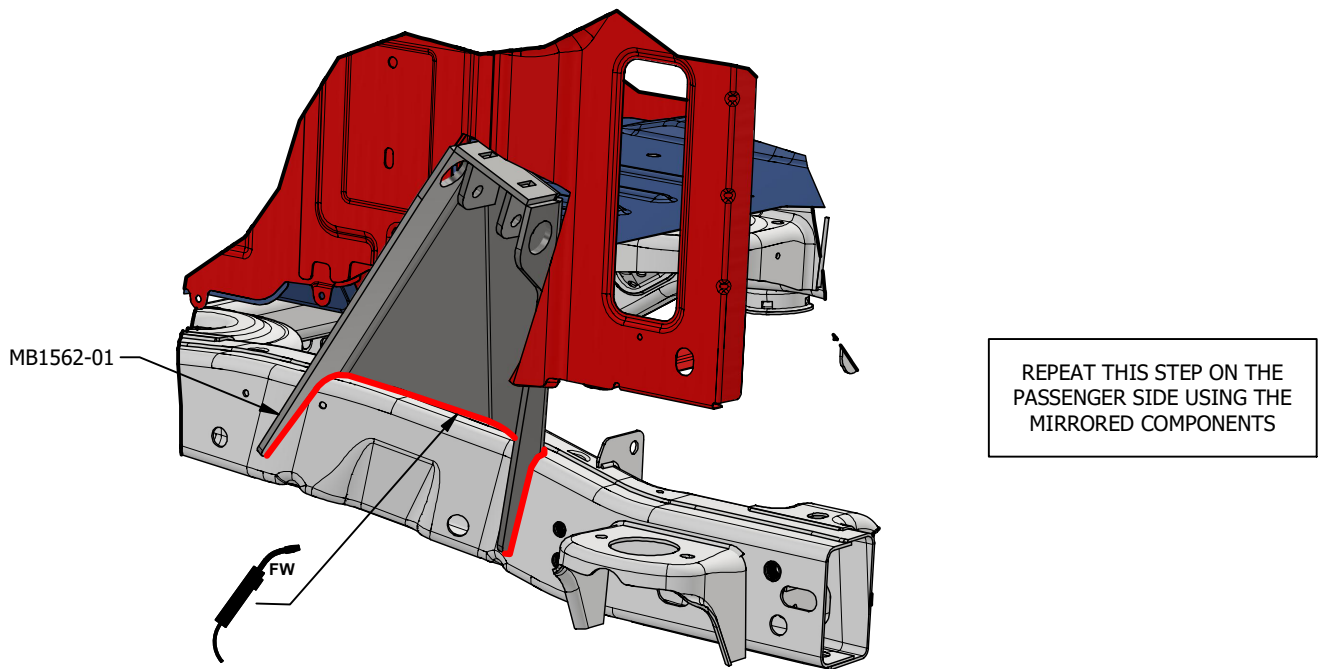
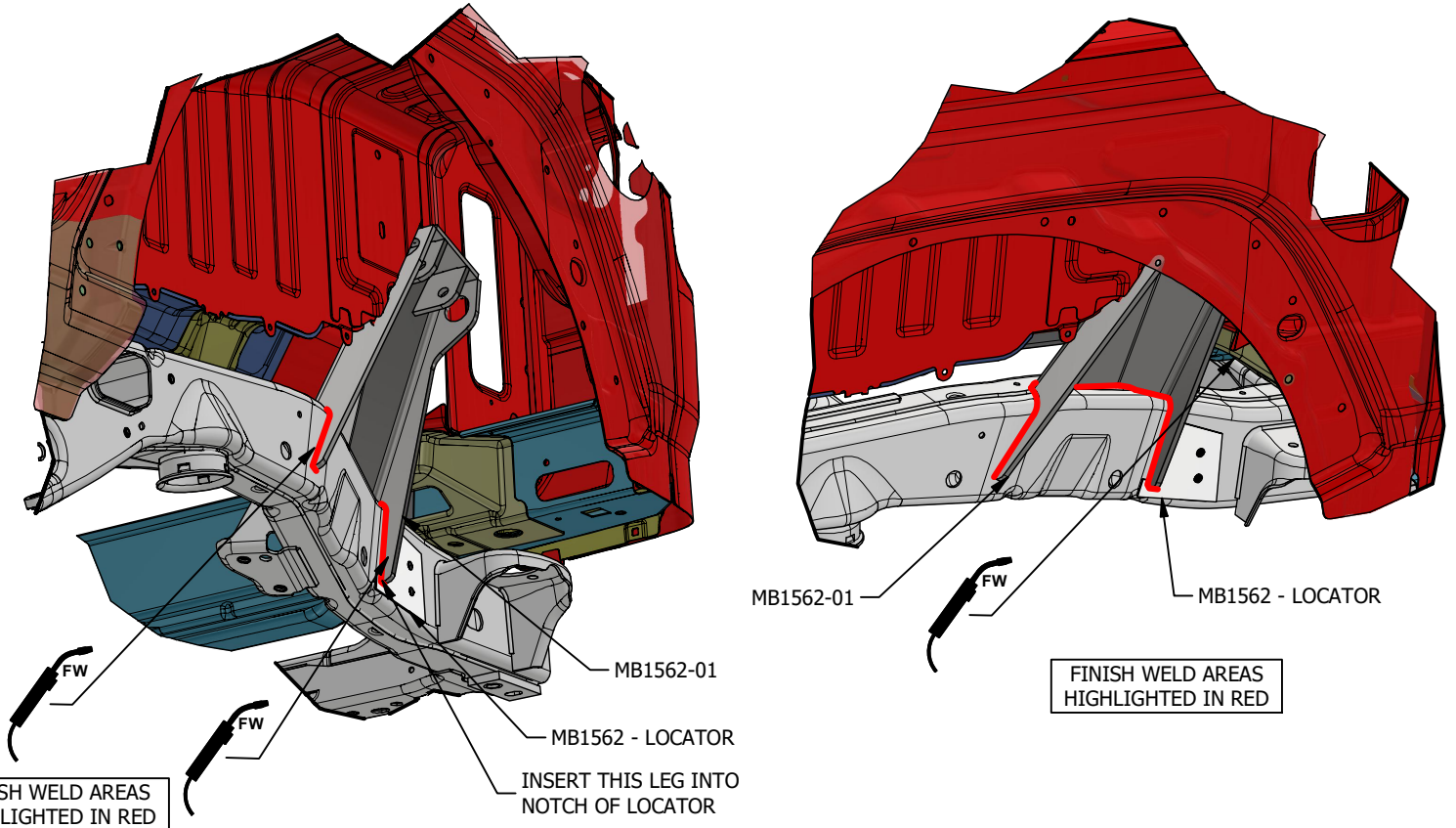

MB1562 - Assembly Instructions Rear Upper Shock Mounts - JL/JLU**BODY PATCH PANEL**

PAINT THE BACK OF THE SHOCK TOWER BEFORE INSTALLING MB1562-03

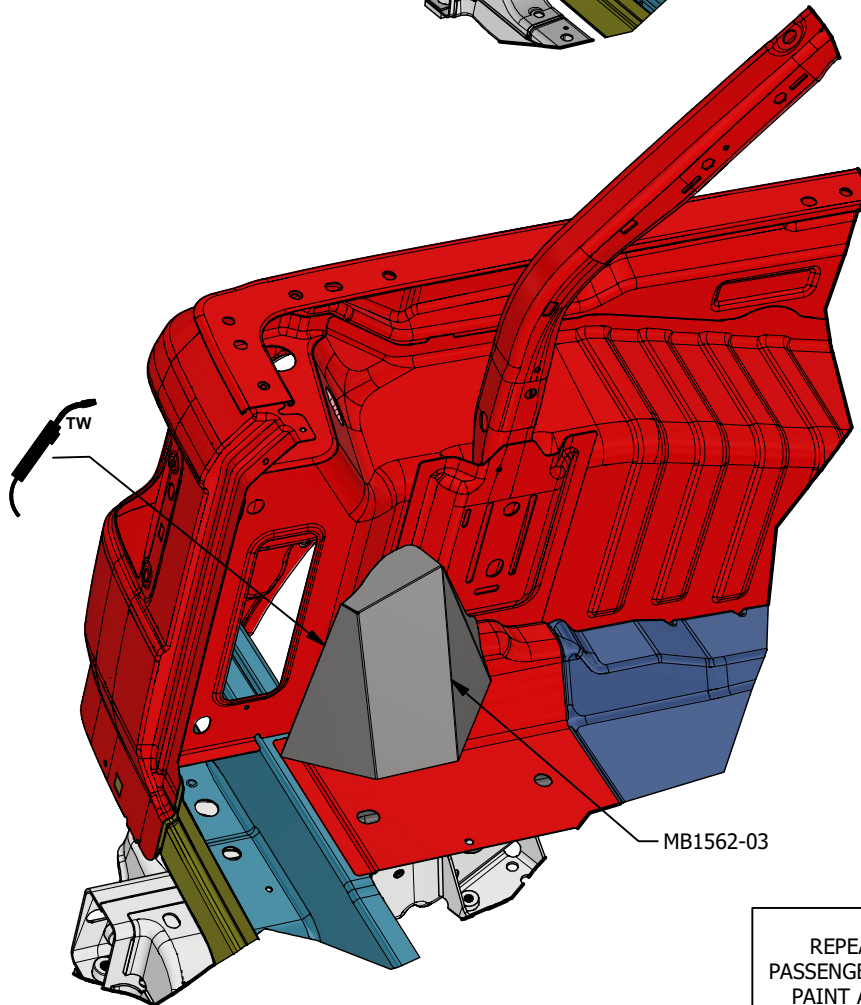
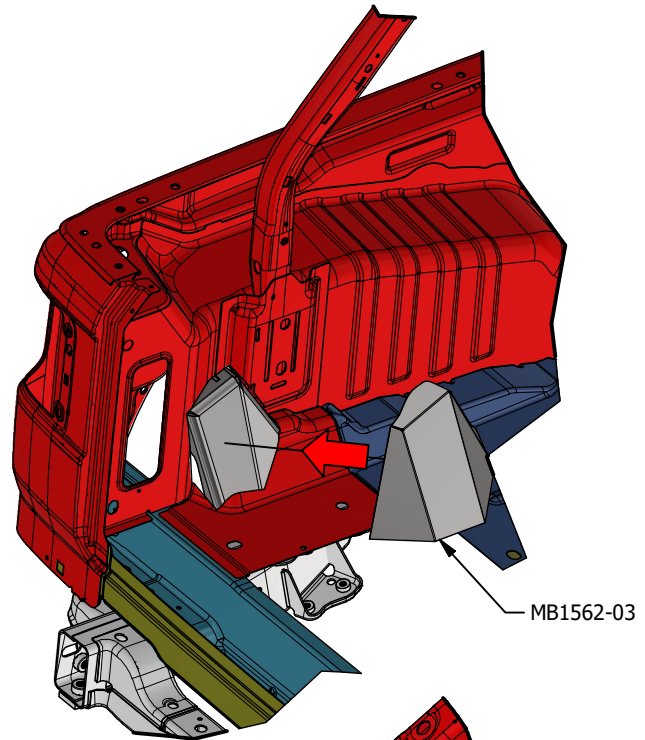

STITCH WELD THE PERIMETER MB1562-03 TO THE BODY BEING CAREFUL NOT TO WARP THE METAL

REPEAT THIS STEP ON THE PASSENGER SIDE WITH MB1562-04. PAINT ALL EXPOSED METAL TO PROTECT IT FROM CORROSION