

MB1185 - Assembly Instructions JT Gladiator Long Bed

ASSEMBLY INSTRUCTIONS

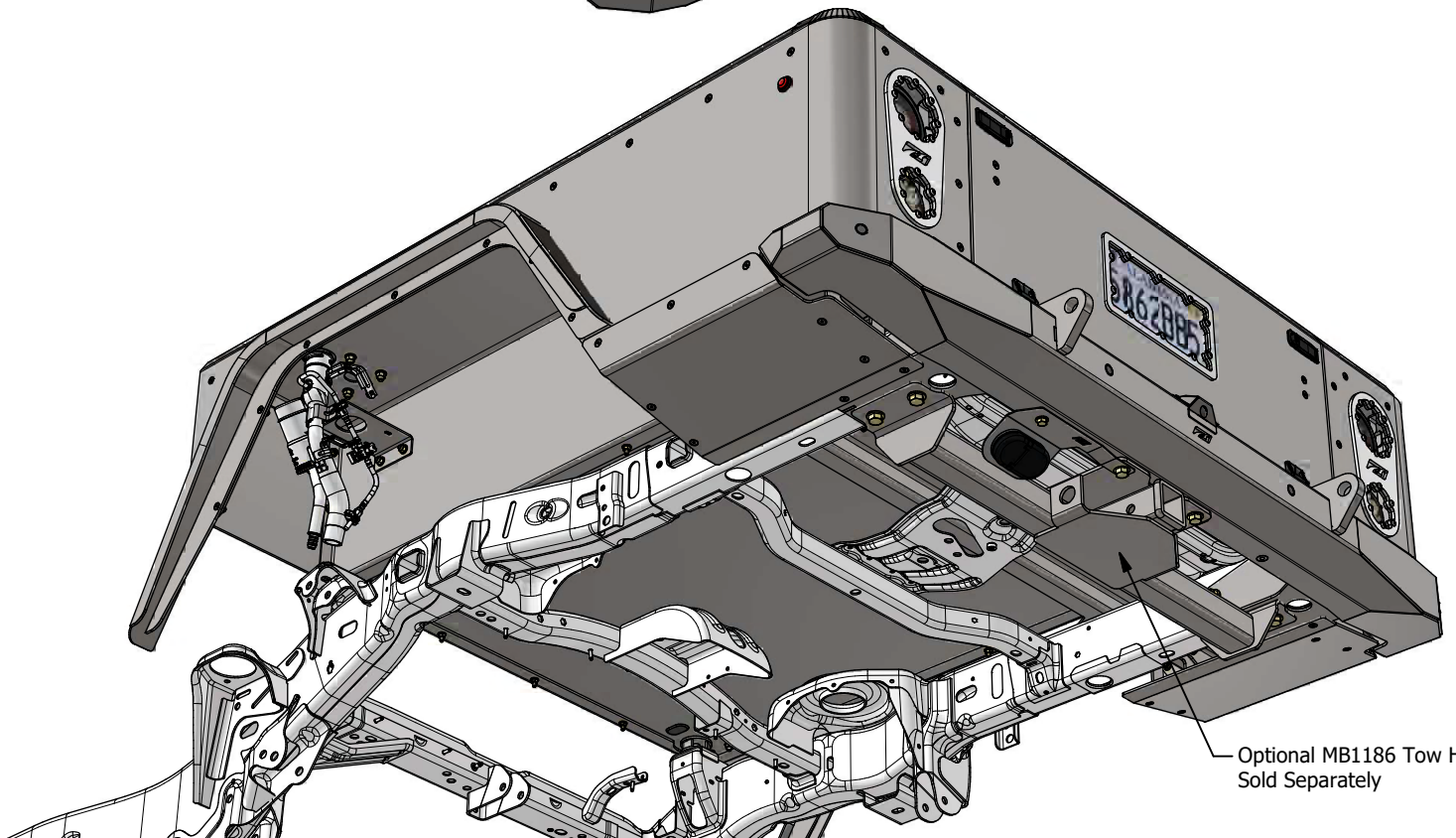
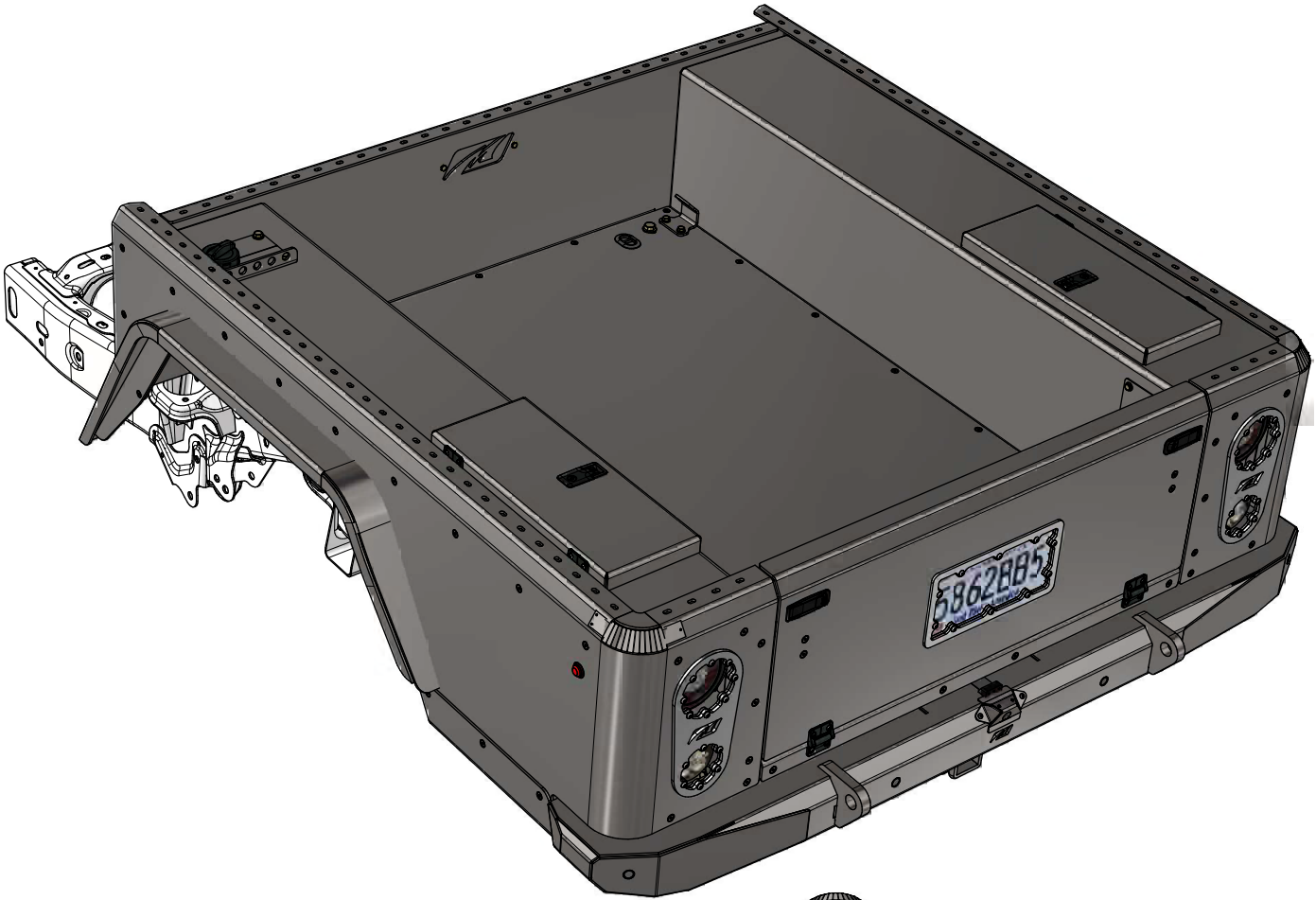

Optional MB1186 Tow Hitch
Sold Separately

MB1185 - Assembly Instructions JT Gladiator Long Bed

CONTENTS

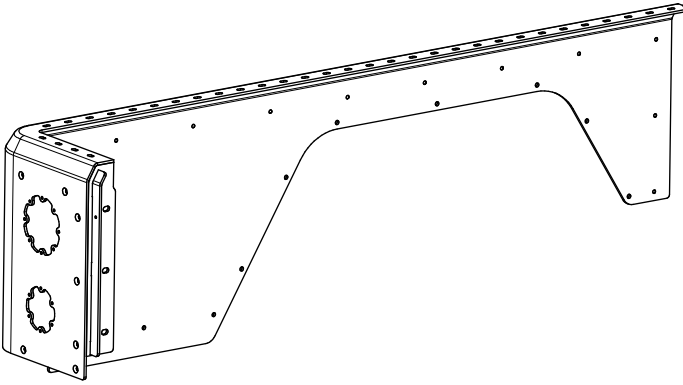

MB1185 - Weldment, Outer Fender Driver Qty 1

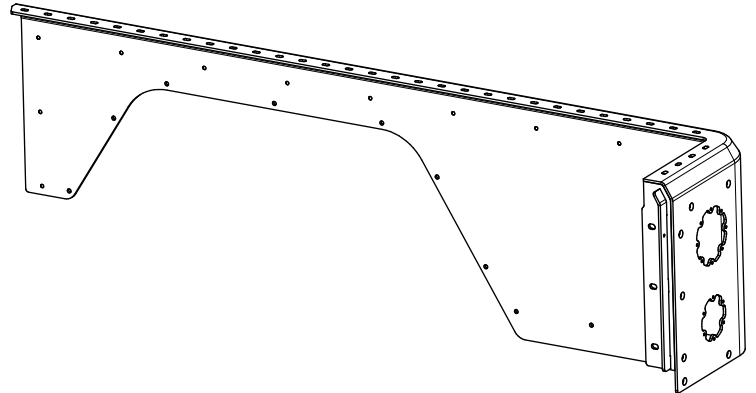

MB1185 - Weldment, Outer Fender Passenger Qty 1

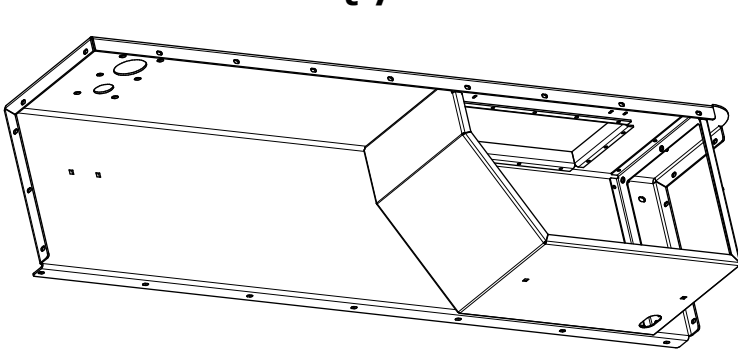

MB1185 - Weldment, Inner Fender Driver Qty 1

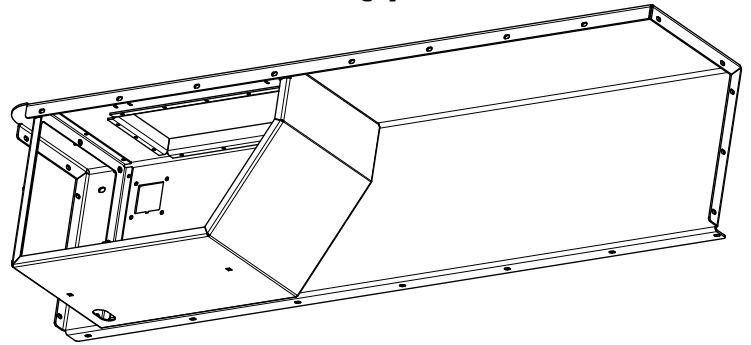

MB1185 - Weldment, Inner Fender Passenger Qty 1

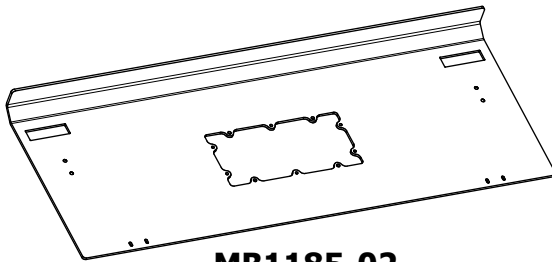

MB1185-02 Qty 1

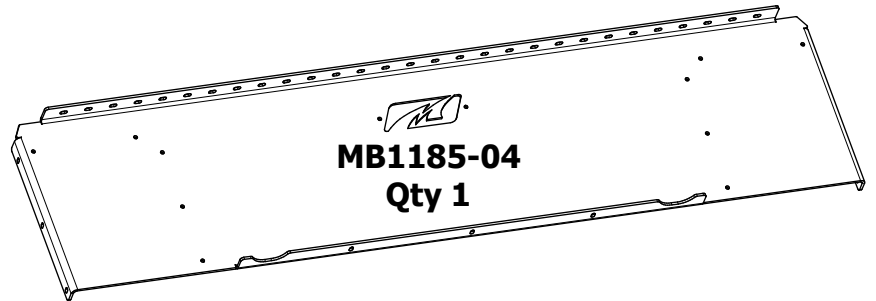

MB1185-04 Qty 1



MB1185 - Weldment, Rear Body Mount 01 Qty 1

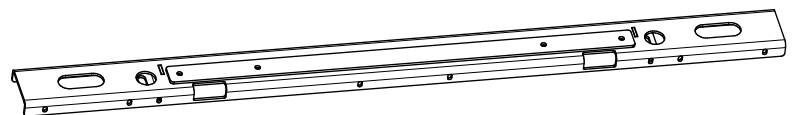

MB1185 - Weldment, Rear Body Mount 02 Qty 1

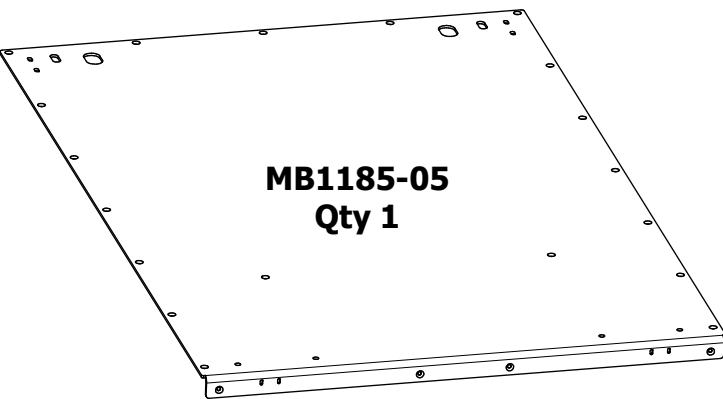

MB1185-05 Qty 1

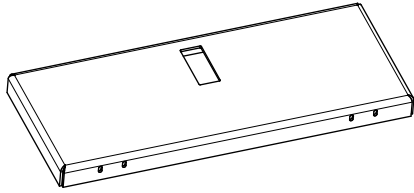
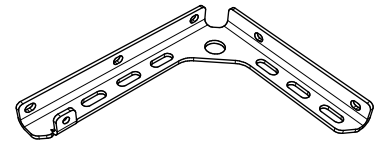
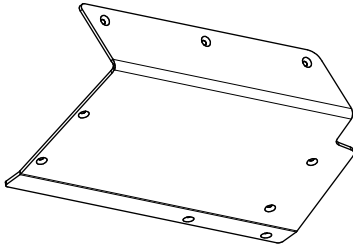
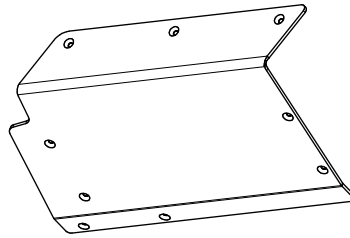
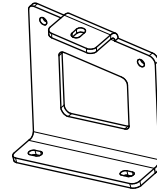
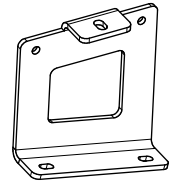
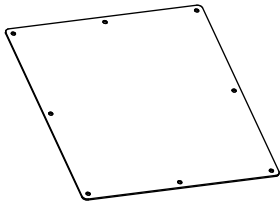
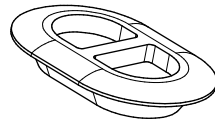
MB1185 - Assembly Instructions JT Gladiator Long Bed**CONTENTS****MB1185-47**
Qty 2**MB1185-12**
Qty 1**MB1185-12_MIR**
Qty 1**MB1185-35**
Qty 1**MB1185-35_MIR**
Qty 1**MB1185-37**
Qty 2**MB1185-37_MIR**
Qty 2**MB1185-39**
Qty 2**Rubber Plug**
Qty 4

MB1185 - Assembly Instructions JT Gladiator Long Bed

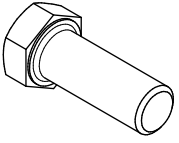
 BAG LABELED AS
1185-KIT01

Hex Bolt
 9/16"-12 x 1-1/2"
 Qty 4

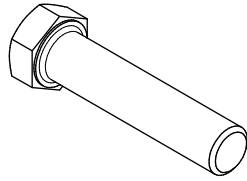

Hex Bolt
 9/16"-12 x 2-1/2"
 Qty 2

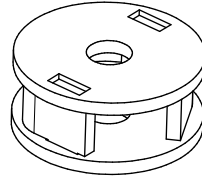

MB1185 - Weldment,
Front Body Mount
 Qty 2



Flat Washer
 9/16"
 Qty 12

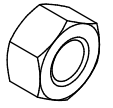

Nylock Nut
 9/16"-12
 Qty 6

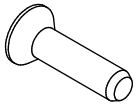
 BAG LABELED AS
1185-KIT02

Countersunk Screw
 1/4"-20 x 3/4"
 Qty 60

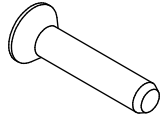

Countersunk Screw
 1/4"-20 x 1-1/4"
 Qty 16

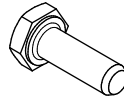

Hex Bolt
 1/4"-20 x 3/4"
 Qty 20



Flat Washer
 1/4"
 Qty 100

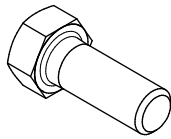

Nylock Nut
 1/4"-20
 Qty 100

 BAG LABELED AS
1185-KIT03

Hex Bolt
 3/8"-16 x 1"
 Qty 10



Flat Washer
 3/8"
 Qty 16

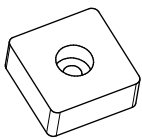

Nylock Nut
 3/8"-16
 Qty 6

 BAG LABELED AS
1185-KIT04

Rubber Bumper
 Qty 2

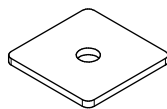

MB1185-32
 Qty 6

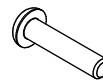

Hex Button Head Screw
 #8-32 x 3/4"
 Qty 2



Machine Nut
 #8-32
 Qty 2

MB1185 - Assembly Instructions JT Gladiator Long Bed

BAG LABELED AS

1185-KIT05

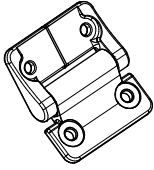

Hinge
Qty 6

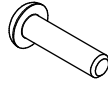

Hex Button Head Screw
#10-24 x 3/4"
Qty 24



Flat Washer
M6
Qty 24



Nylock Nut
#10-24
Qty 24

BAG LABELED AS

1185-KIT06



Tailgate Cable
Qty 2

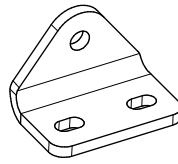

MB1185-26
Qty 2



MB1185-25
Qty 2

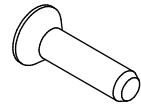

Countersunk Screw
1/4"-20 x 3/4"
Qty 4

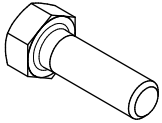

Hex Bolt
5/16"-18 x 1"
Qty 4



Flat Washer
5/16"
Qty 6



Nylock Nut
5/16"-18
Qty 4



Hex Nut
5/16"-18
Qty 2



Flat Washer
1/4"
Qty 4



Nylock Nut
1/4"-20
Qty 4

BAG LABELED AS

1185-KIT07

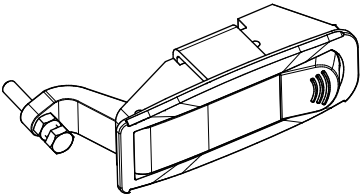

Push Latch
Qty 2

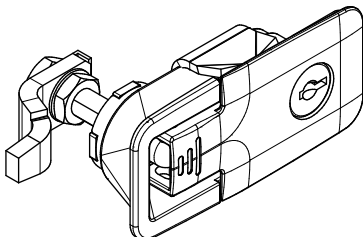

Locking Latch
Qty 2

BAG LABELED AS

1185-KIT08

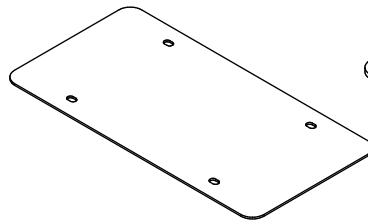

MB1185-29
Qty 1

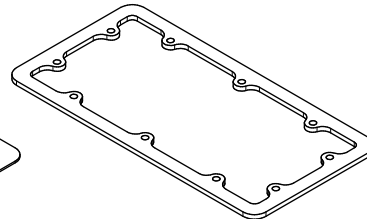

MB1185-24
Qty 1

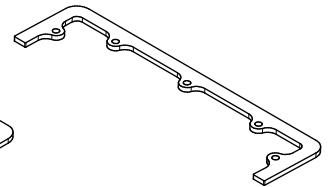

MB1185-31
Qty 2

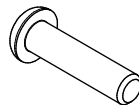

Hex Button Head Screw
1/4"-20 x 1"
Qty 4



Hex Button Head Screw
1/4"-20 x 1/2"
Qty 6



Cap Nut
1/4"-20
Qty 4

MB1185 - Assembly Instructions JT Gladiator Long Bed

BAG LABELED AS
1185-KIT09

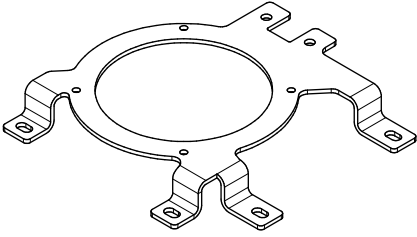

MB1185-22
Qty 1

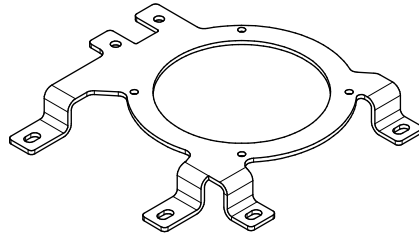

MB1185-22_MIR
Qty 1

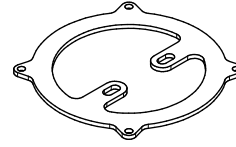

MB1185-30
Qty 2



MB1185-28
Qty 2

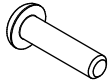

Hex Button Head Screw
#10-24 x 3/4"
Qty 8



Nylock Nut
#10-24
Qty 8

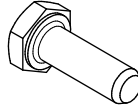

Hex Bolt
1/4"-20 x 3/4"
Qty 4



Flat Washer
1/4"
Qty 4



Nylock Nut
1/4"-20
Qty 4

BAG LABELED AS
1185-KIT10

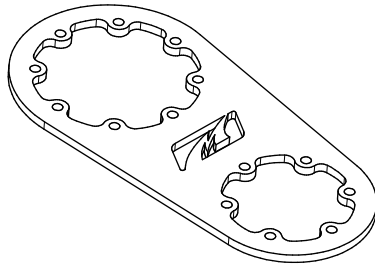

MB1178-23
Qty 2



Hex Button Head Screw
1/4"-20 x 3/4"
Qty 28

BAG LABELED AS
1185-KIT11

Not Applicable

MB1185 - Assembly Instructions JT Gladiator Long Bed

 GASOLINE COMPATIBLE PARTS
SHOWN IN RED

 BAG LABELED AS
1185-KIT12

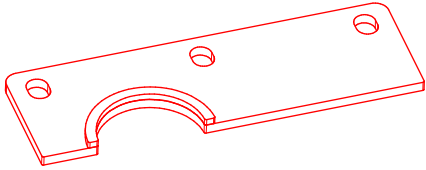
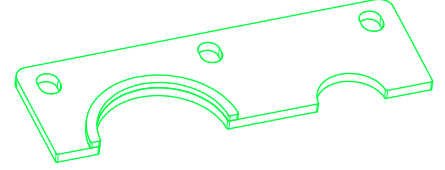
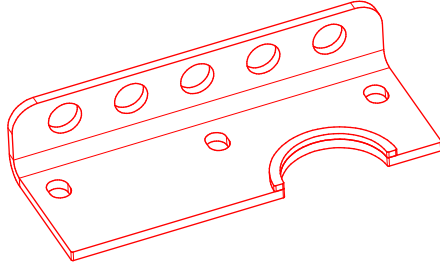
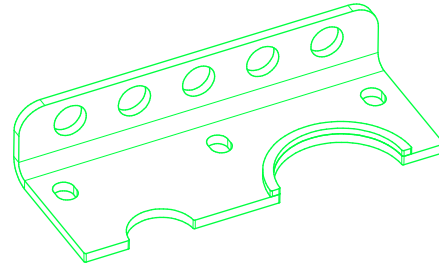
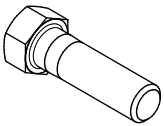
 DIESEL COMPATIBLE PARTS
SHOWN IN GREEN

**MB1185 - Weldment,
Filler Clamp 01 - Gas
Qty 1**

**MB1185 - Weldment,
Filler Clamp 01 - Diesel
Qty 1**

**MB1185 - Weldment,
Filler Clamp 02 - Gas
Qty 1**

**MB1185 - Weldment,
Filler Clamp 02 - Diesel
Qty 1**

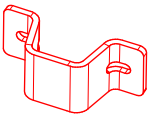
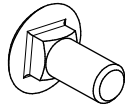
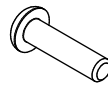
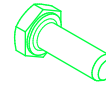
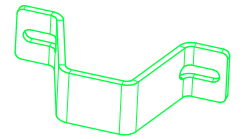
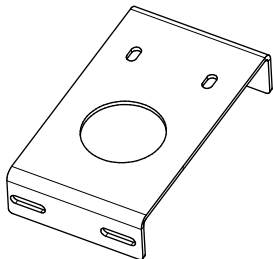
**Hex Bolt
3/8"-16 x 1-1/2"
Qty 6**

**Flat Washer
3/8"
Qty 12**

**Nylock Nut
3/8"-14
Qty 6**

 GASOLINE COMPATIBLE PARTS
SHOWN IN RED

 BAG LABELED AS
1185-KIT13

 DIESEL COMPATIBLE PARTS
SHOWN IN GREEN

**MB1185-46
Nozzle Clamp 01 - Gas
Qty 1**

**Carriage Bolt
5/16" x 3/4"
Qty 6**

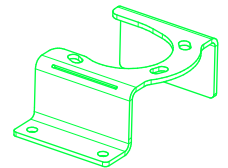
**Hex Button Head Screw
#10-24 x 3/4"
Qty 20**

**Hex Bolt
1/4"-20 x 3/4"
Qty 5**

**MB1185-15
Nozzle Clamp 02 - Diesel
Qty 1**

**MB1185-16
Mounting Plate Clamp
(common to both Gas & Diesel)
Qty 1**

**Flat Washer
5/16"
Qty 6**

**Flat Washer
M6
Qty 20**

**Flat Washer
1/4"
Qty 10**

**MB1185-40
Nozzle Clamp 03 - Diesel
Qty 1**

**Nylock Nut
5/16"-18
Qty 6**

**Nylock Nut
#10-24
Qty 20**

**Nylock Nut
1/4"-20
Qty 5**

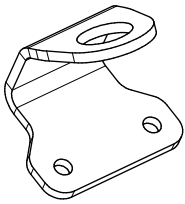
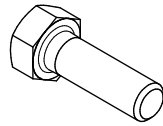
MB1185 - Assembly Instructions JT Gladiator Long Bed

 BAG LABELED AS
1185-KIT14

MB1185-21
 Qty 2

Hex Bolt
 5/16"-18 x 1"
 Qty 4

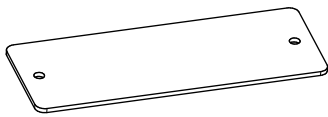
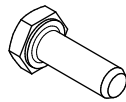
Flat Washer
 5/16"
 Qty 8

Nylock Nut
 5/16"-18
 Qty 4

 BAG LABELED AS
1185-KIT15

MB1185-20
 Qty 1

Hex Bolt
 1/4"-20 x 3/4"
 Qty 2

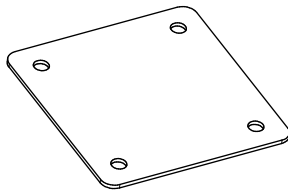
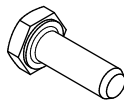
Flat Washer
 1/4"
 Qty 2

Nylock Nut
 1/4"-20
 Qty 2

 BAG LABELED AS
1185-KIT16

MB1185-27
 Qty 1

Hex Bolt
 1/4"-20 x 3/4"
 Qty 4

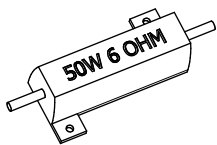
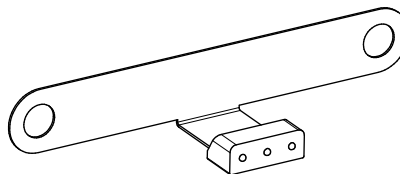
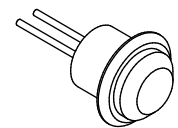
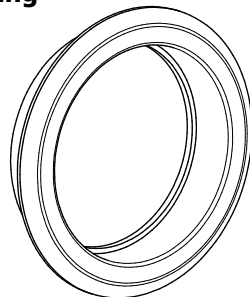
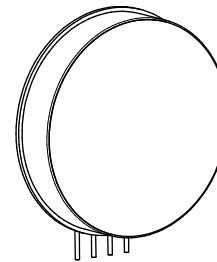
Flat Washer
 1/4"
 Qty 8

Nylock Nut
 1/4"-20
 Qty 4

 BAG LABELED AS
1185-KIT17

MB5519
 Resistor for Non-LED Wiring
 Qty 2

Light, License Plate
 Qty 1

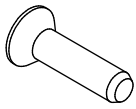
Side Marker Light
 Qty 2

MB6502
 Grommet
 Qty 2

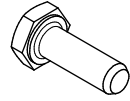
MB6502
 LED Tail Light
 Qty 2

MB1185 - Assembly Instructions JT Gladiator Long Bed

BAG LABELED AS
1185-SPARES



Countersunk Screw
1/4"-20 x 3/4"
Qty 10



Hex Bolt
1/4"-20 x 3/4"
Qty 10



Flat Washer
1/4"
Qty 10



Nylock Nut
1/4"-20
Qty 10

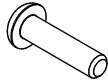

Hex Button Head Screw
#10-24 x 3/4"
Qty 10



Nylock Nut
#10-24
Qty 10



Hex Button Head Screw
1/4"-20 x 1/2"
Qty 10

MB1179 - Assembly Rear Fenders

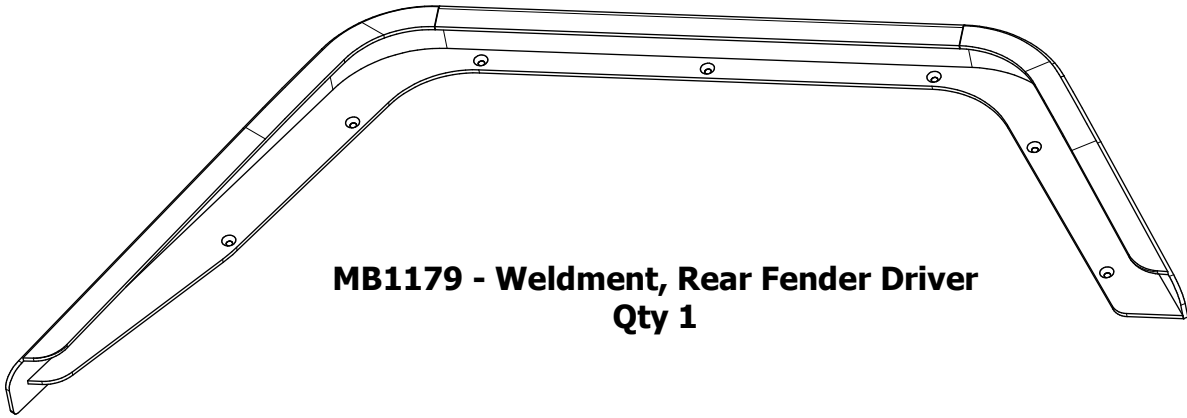

**MB1179 - Weldment, Rear Fender Driver
Qty 1**

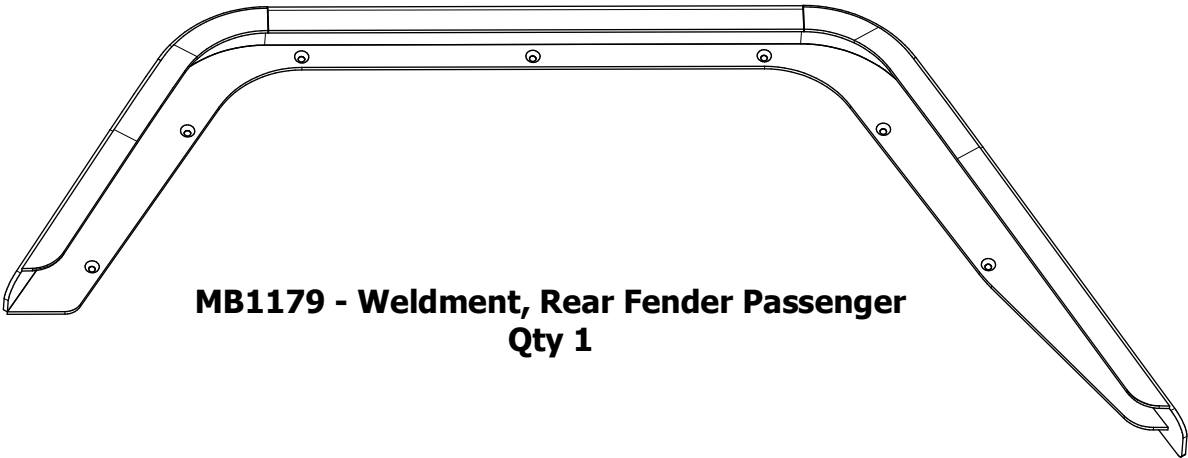

**MB1179 - Weldment, Rear Fender Passenger
Qty 1**

BAG LABELED AS

1179

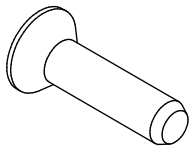

**Countersunk Screw
1/4"-20 x 3/4" Long
Qty 14**

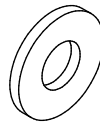

**Flat Washer
1/4"
Qty 14**

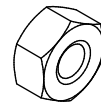

**Nylock Nut
1/4"-20
Qty 14**

MB1187 - Assembly Rear Bumper

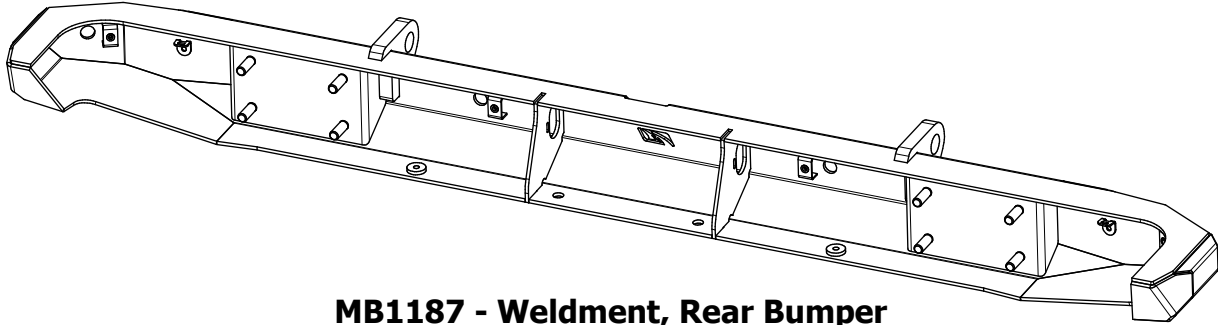

MB1187 - Weldment, Rear Bumper
Qty 1

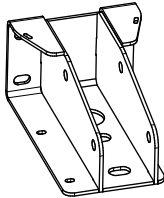

MB1187 - Weldment, Frame Mount Passenger
Qty 1

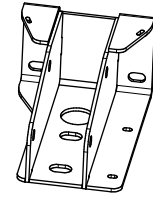

MB1187 - Weldment, Frame Mount Driver
Qty 1

BAG LABELED AS
1187

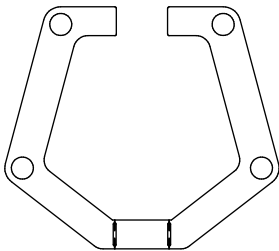

MB1187-12
Qty 2

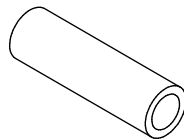

MB1187-Tube 01
Qty 4

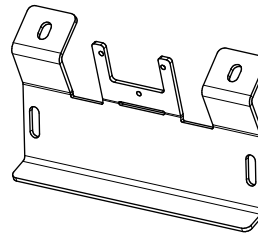

MB1187-11
Qty 1

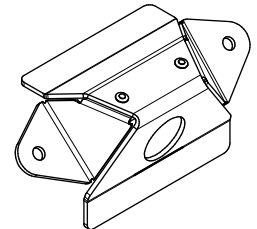

MB1187-Camera Housing
Qty 1

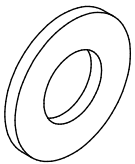

Flat Washer
1/2"
Qty 16



Flat Washer
M6
Qty 2

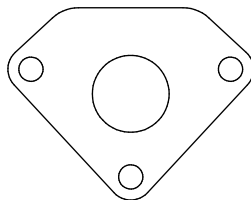

MB2115-08
Qty 1



Nylock Nut
#10-24
Qty 2



Screw
M3-0.5 x 8mm
Qty 3

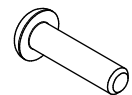

Hex Button Head Screw
#10-24 x 3/4"
Qty 6

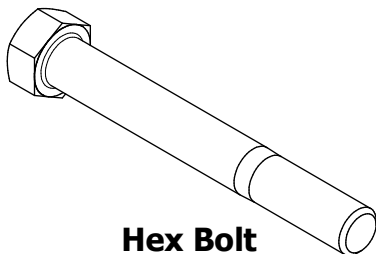

Hex Bolt
1/2"-13 x 4"
Qty 4

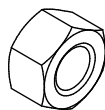

Nylock Nut
1/2"-13
Qty 12

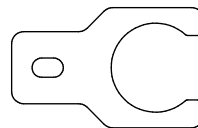

MB2117-01
Qty 4

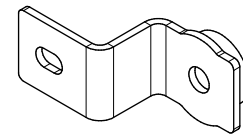

MB2145
Park Sensor Blank Off
Qty 4

MB1185 - Assembly Instructions JT Gladiator Long Bed

PREPARATION

Cleaning/Paint/Finishing

All Motobilt parts are shipped as raw (unfinished) steel. A light coating of anti-corrosion oil may be present on all manufactured parts to prevent corrosion during shipping. Apply acetone to all steel parts & thoroughly clean before applying paint.

We recommend to paint or powder coat all steel parts prior to installation.

Factory Gladiator Bed Removal

1. Disconnect negative battery terminal.
2. Disconnect all wiring connecting rear bumper & bed to the frame. Unplug tail light connections at the frame, driver side rear above the tire & passenger side rear above the tire.
3. Remove factory rear bumper. If equipped, remove all sensors & wiring harness from inside the rear bumper.
4. Using a 15mm socket & socket extension, remove six (6) factory bolts that secure the factory bed to the frame. There are four (4) bolts behind the axle inside the frame tube. There are two (2) bolts in front of the axle inboard of the frame tube.
5. Unhook the fuel filler hose, breather hose & electrical connections from beneath the fuel fill cap location.
6. Due the weight of the factory Gladiator bed, you may need four (4) or more people to manually lift the bed off the frame. If using a forklift or crane, use approved slings & safe lifting practices to ensure everyone's safety during bed removal. You may need to lift the bed at an angle, rather than lifting straight up vertically, to avoid contact with the cab.
7. With the factory bed safely removed from the frame, remove all remaining wiring harnesses from the bed.

8. If equipped, remove the 120 volt receptacle from the factory bed.

9. If equipped, remove the factory rear camera from the tail gate.

10. Protect the cab, all painted areas & all glass using a fireproof (or welders) blanket or similar.

11. Seal & protect all open fuel hoses or connections from open flame or sparks.

Sensor Compatibilty (if equipped)

The MB1185 Gladiator Long Bed Kit is designed to **NOT** work with the blind spot sensors located in the tail llights. If your Gladiator is equipped with blind spot sensors in the tail light housing, they can be programmed to be turned off by using an aftermarket programmer.

The MB1187 Gladiator Rear Bumper **IS** designed to reuse the park assist sensors in the factory rear bumper. The kit also includes blank off plates if your vehicle does not include the factory park assist sensors.

MB1185 - Assembly Instructions JT Gladiator Long Bed

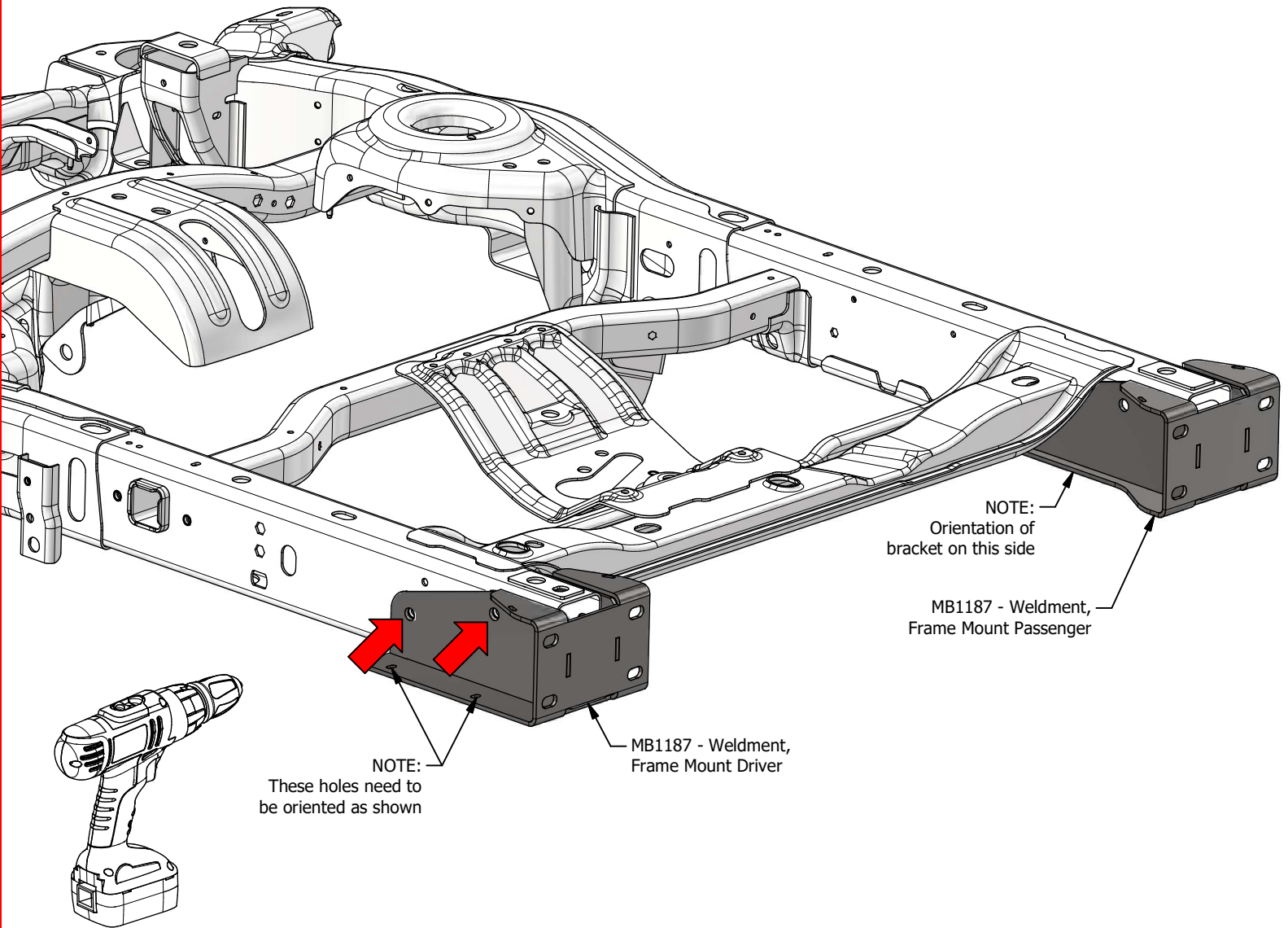
BUMPER ASSEMBLY STEP 1

1. Temporarily clamp MB1187 - Weldment, Frame Mount Driver & MB1187 - Weldment, Frame Mount Passenger (a.k.a. "brackets") to the ends of the factory frame as shown. Align with existing threaded holes in the frame.
2. With the brackets temporarily clamped in place & aligned, use a Drill with 1/2" diameter drill bit to drill through the existing threaded inserts in the frame & drill all the way through to match with the holes in the brackets on the opposite side of the frame.
3. Check fitment of 1/2" bolts in all four (4) drilled holes.
4. Remove brackets from frame.
5. Paint all MB1187 bumper components.

MB1185 - Assembly Instructions JT Gladiator Long Bed

BUMPER ASSEMBLY STEP 2

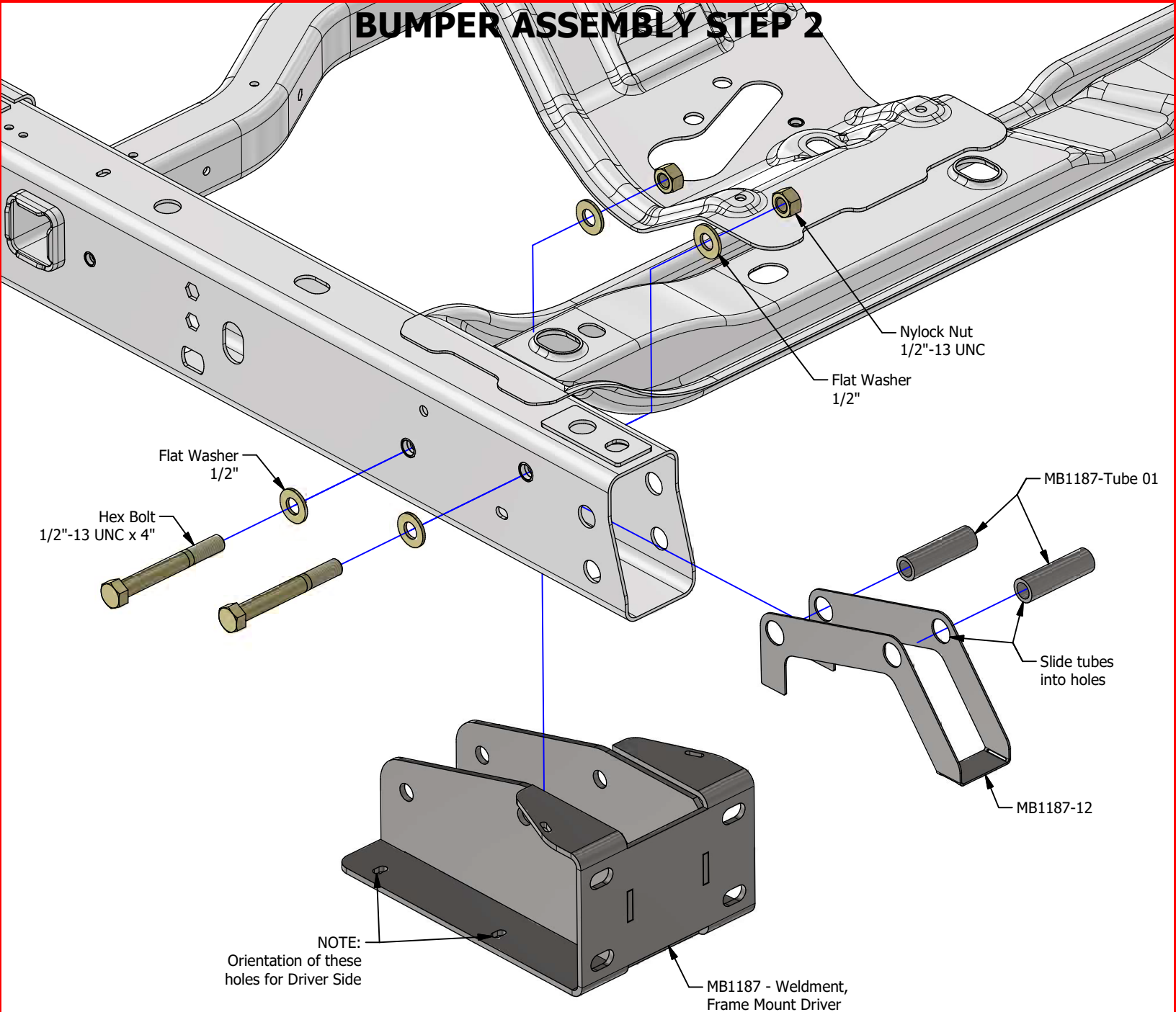

**REPEAT ON
OPPOSITE SIDE
&
TIGHTEN
FASTENERS**

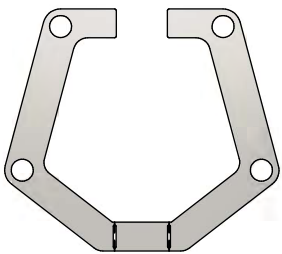

**MB1187-12
Ships Flat
Qty 2**

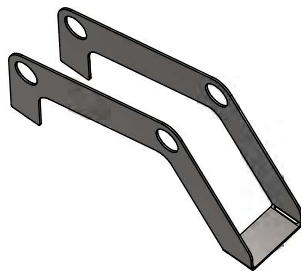

**MB1187-12
After Forming By Hand
Qty 2**

USE BAG LABELED AS
1187

MB1185 - Assembly Instructions JT Gladiator Long Bed

BUMPER ASSEMBLY STEP 3

Place your factory rear bumper face down with the wiring facing up.

Label the positions of all wiring connections & park sensors. Example: Park Sensor - Outer Driver, Park Sensor - Middle Driver, Park Sensor - Outer Passenger, Park Sensor - Middle Passenger, Connector - Driver, Connector - Passenger, License Plate Light - Driver, License Plate Light - Passenger.

The wiring connectors that connect the bumper wiring harness to the vehicle's main wiring harness on the driver side are a different shape than the wiring connectors on the passenger side. Labeling them now will ensure you position the bumper wiring harness correctly into your new Motobilt bumper. Also, the positions of the park sensors must be placed back into their relative positions in the new bumper.

Disconnect the four (4) park sensors from the factory rear bumper by opening the plastic bezels slightly with a screwdriver to remove them. The factory plastic bezels will not be reused.

Remove the complete factory wiring & sensors from the factory bumper.



MB1185 - Assembly Instructions JT Gladiator Long Bed

BUMPER ASSEMBLY STEP 4

Install the factory rear bumper wiring harness & factory rear park sensors in the new MB1187 Motobilt Rear Bumper. Place sensors back into their relative positions using your labeling from the previous step.

The sensor fits into the hole in the bumper. Use the provided sensor clamps (MB2117-01) to secure the park sensor. Repeat for the other three (3) park sensors.

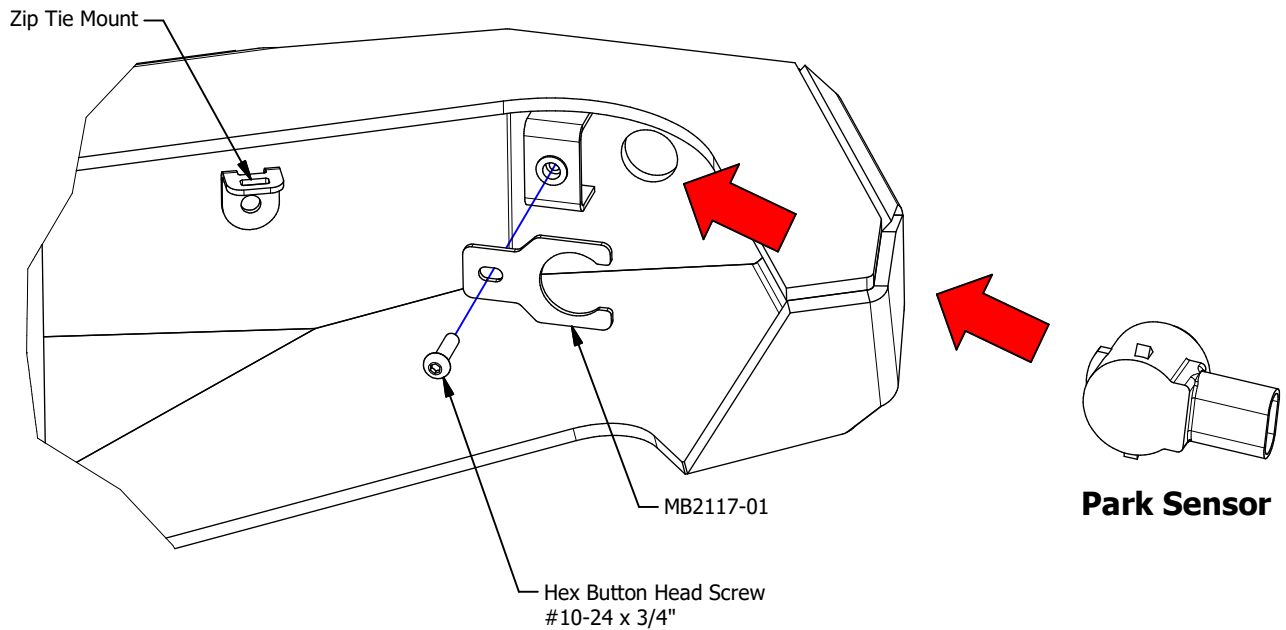
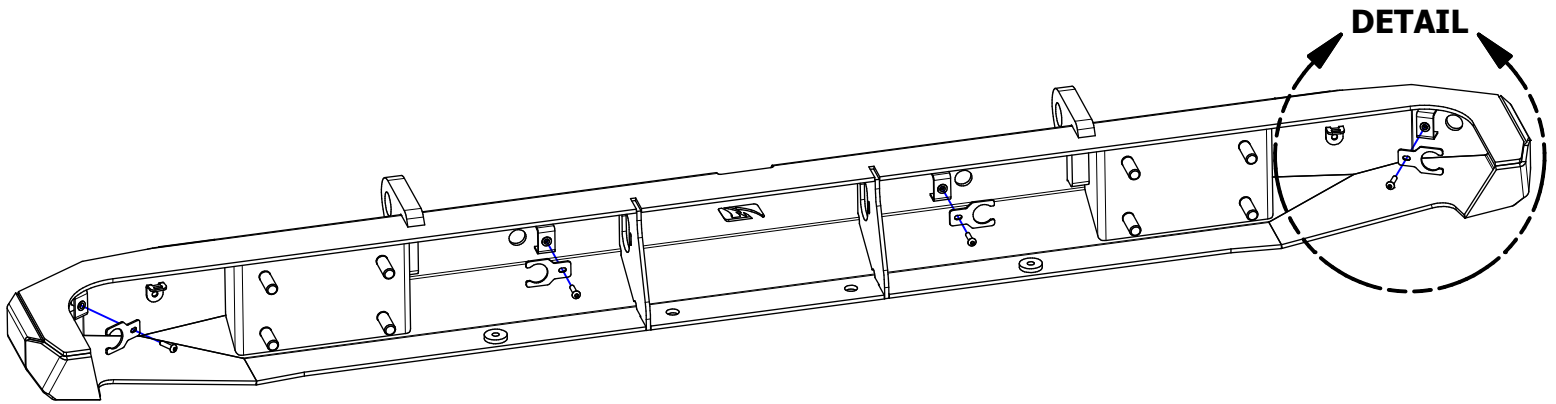

USE BAG LABELED AS
1187

MB1185 - Assembly Instructions JT Gladiator Long Bed

BUMPER ASSEMBLY STEP 5

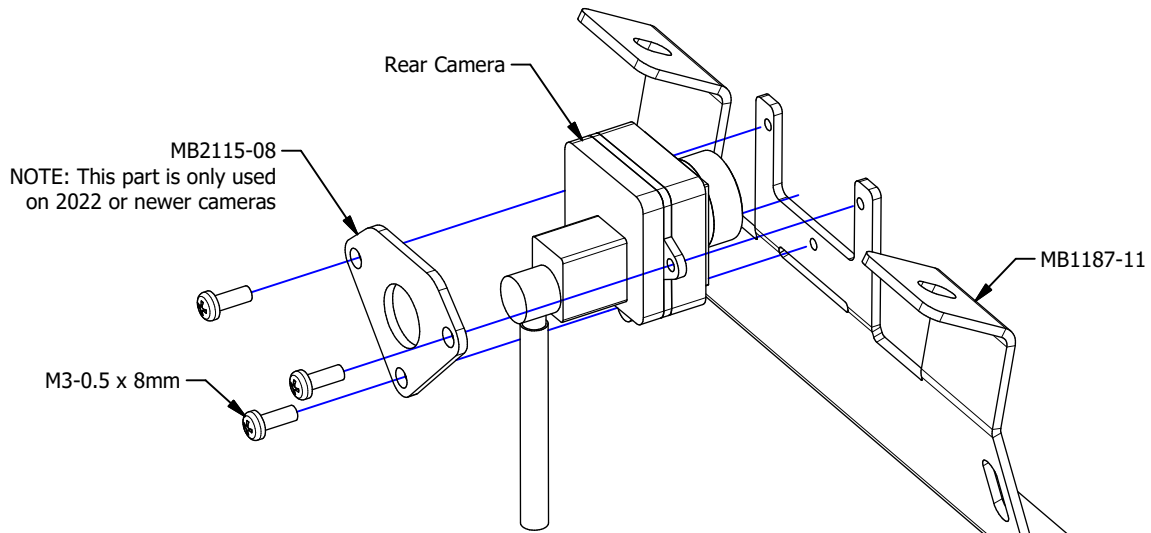

**TIGHTEN
FASTENERS**

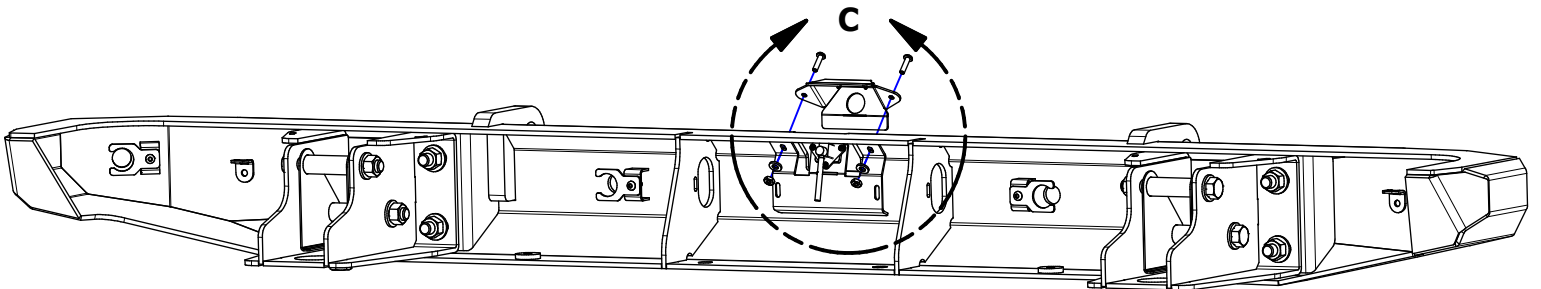
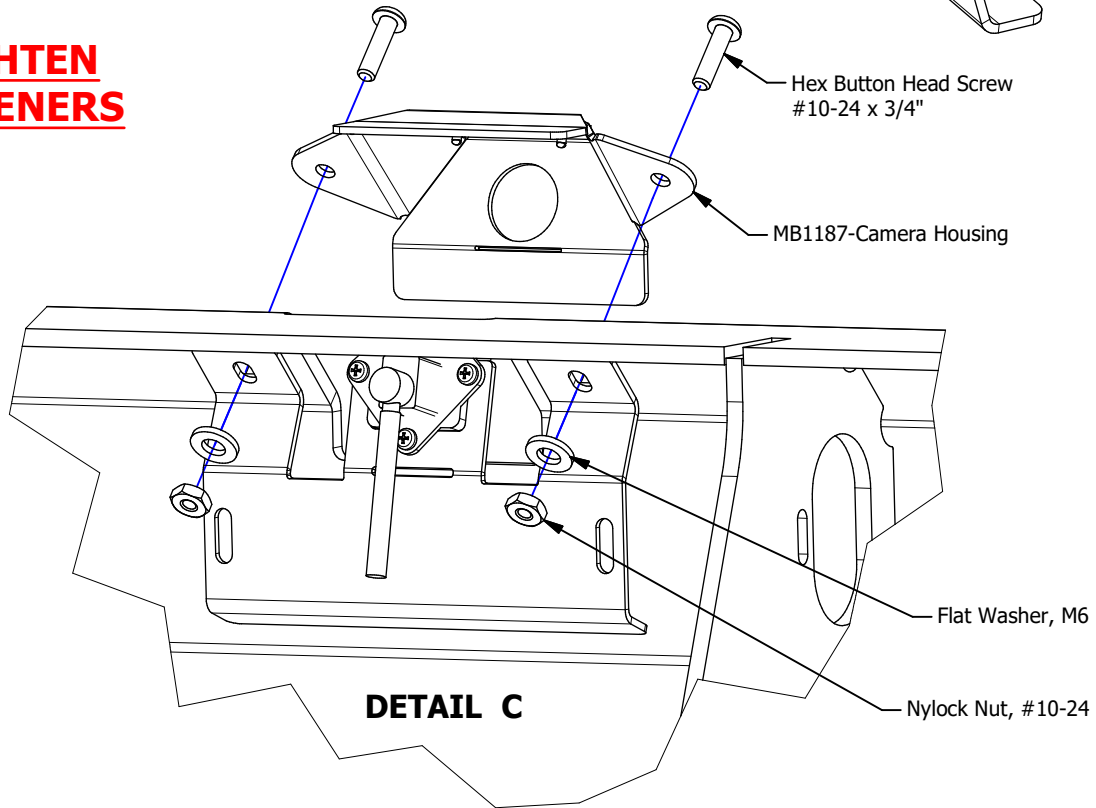

USE BAG LABELED AS
1187

BUMPER ASSEMBLY STEP 6

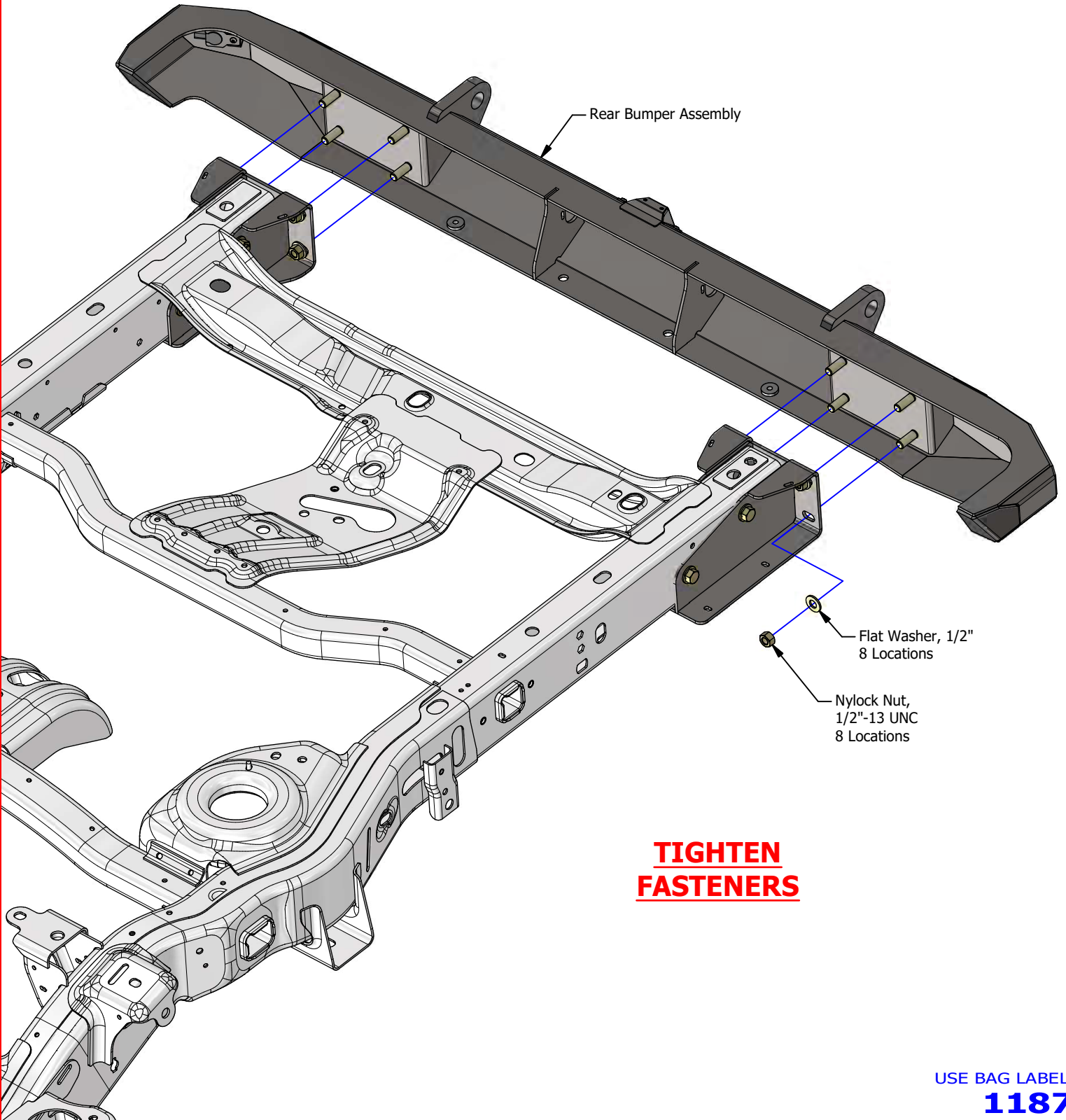

USE BAG LABELED AS
1187

MB1186 - Assembly Instructions Tow Hitch for MB1185

MB1186 TOW HITCH
SOLD SEPARATELY

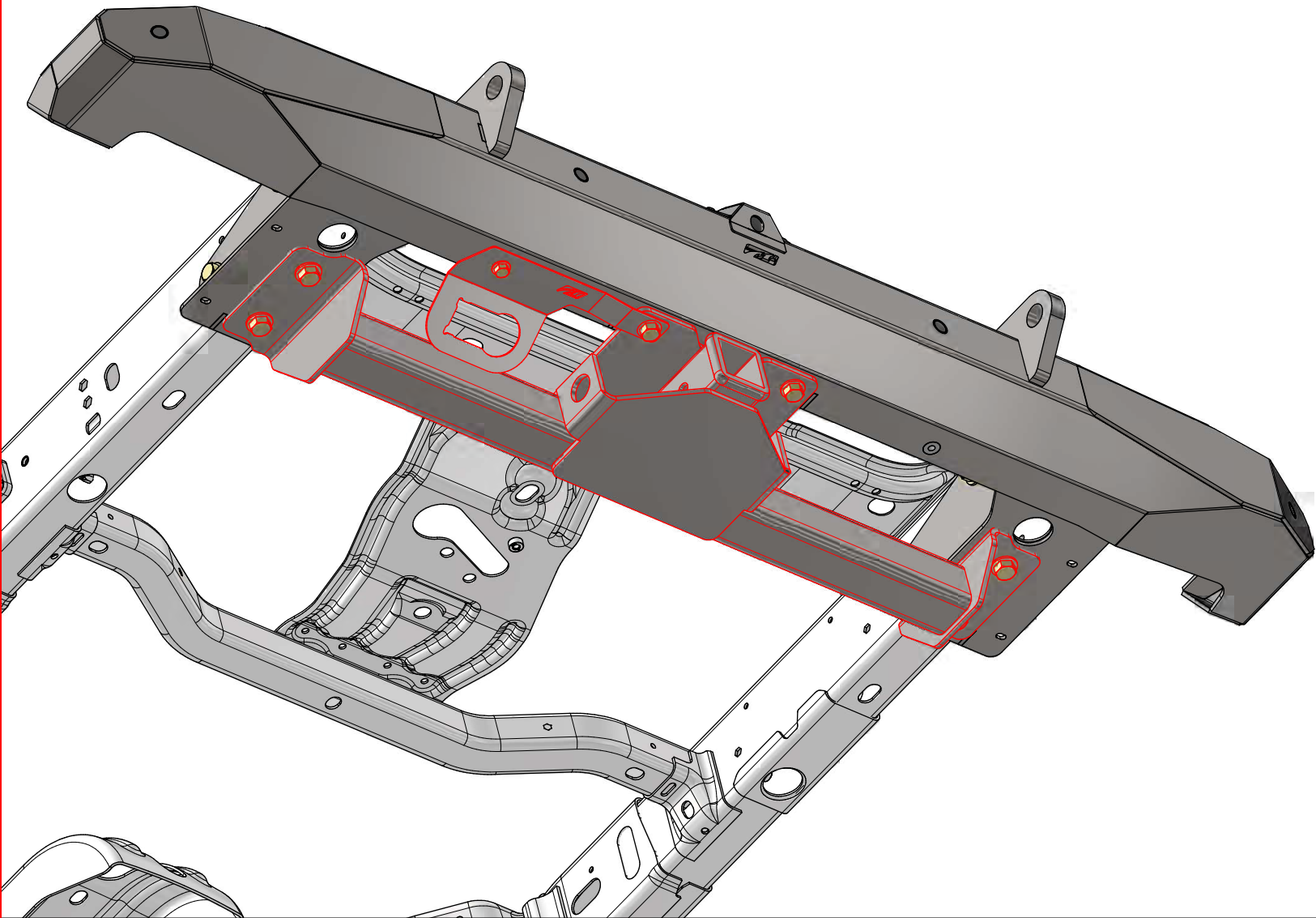
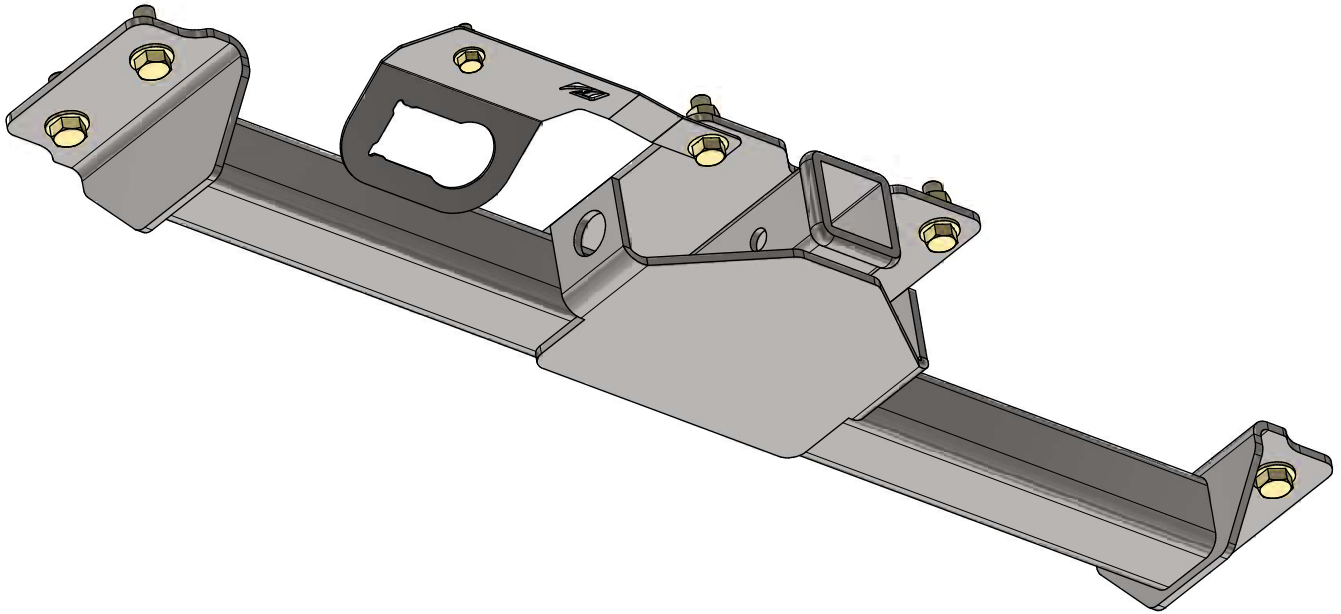

MB1185 - Assembly Instructions JT Gladiator Long Bed

BED ASSEMBLY STEP 1

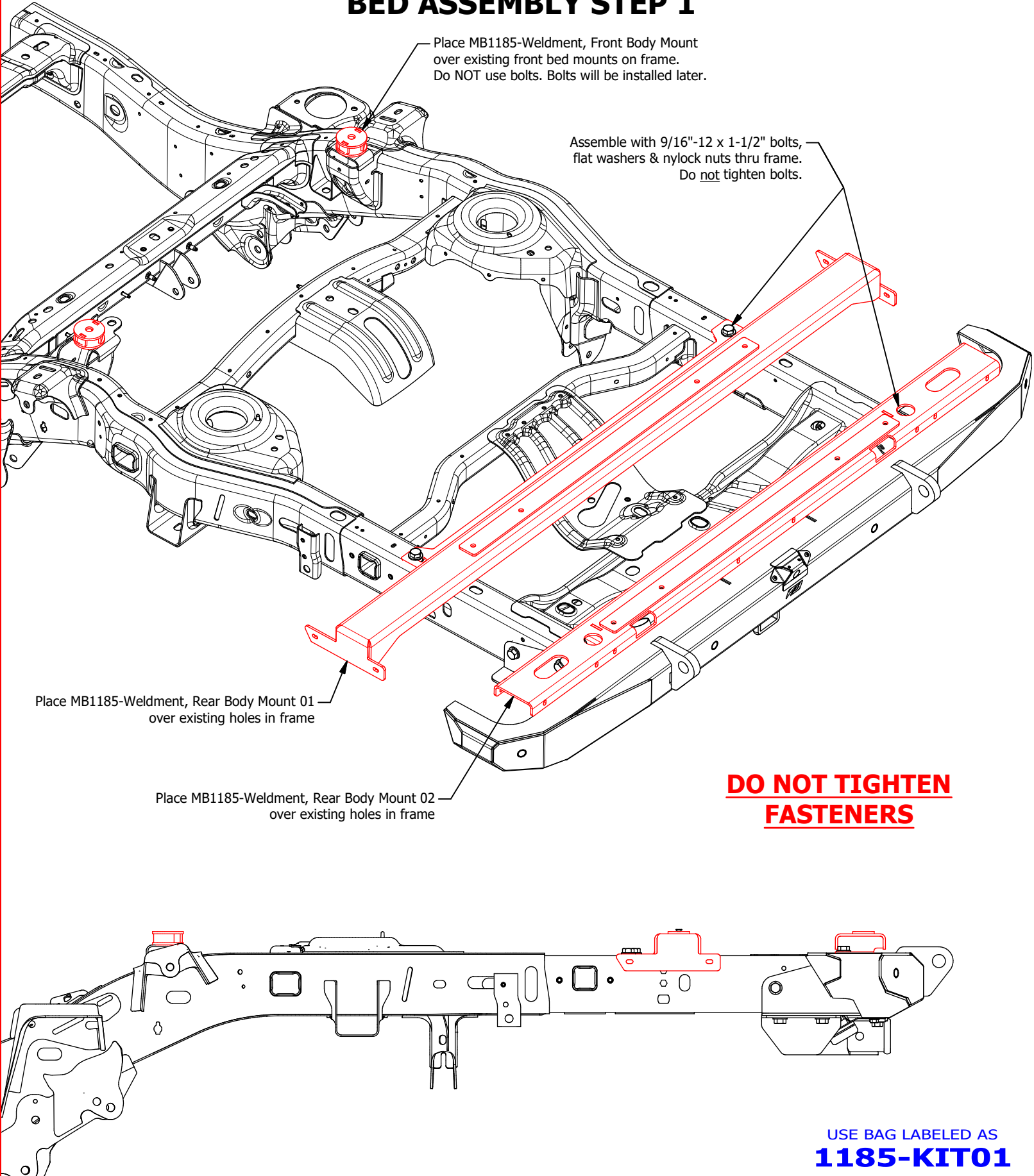

MB1185 - Assembly Instructions JT Gladiator Long Bed

BED ASSEMBLY STEP 2

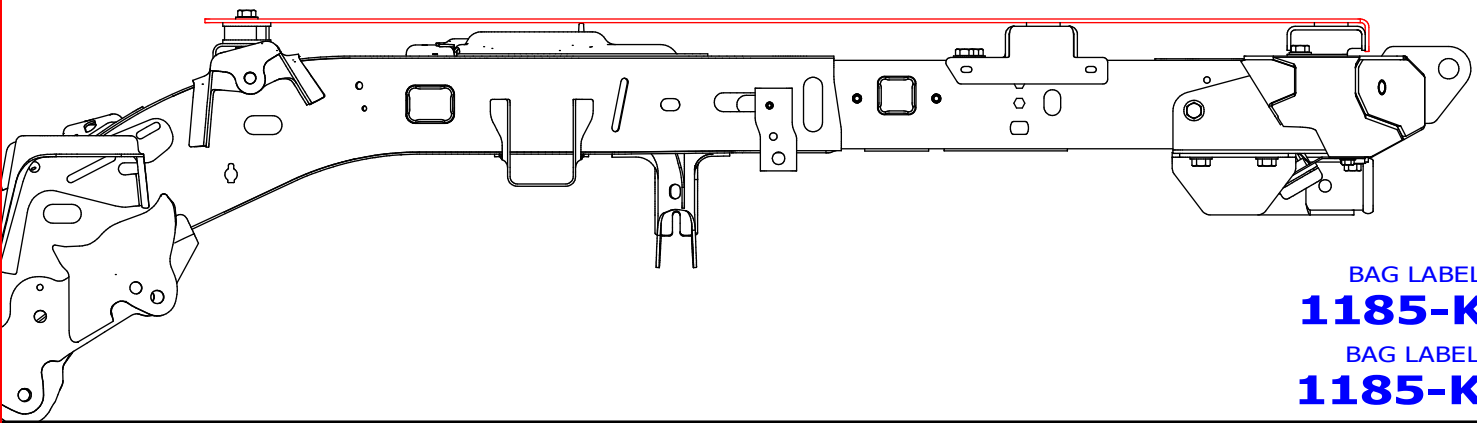
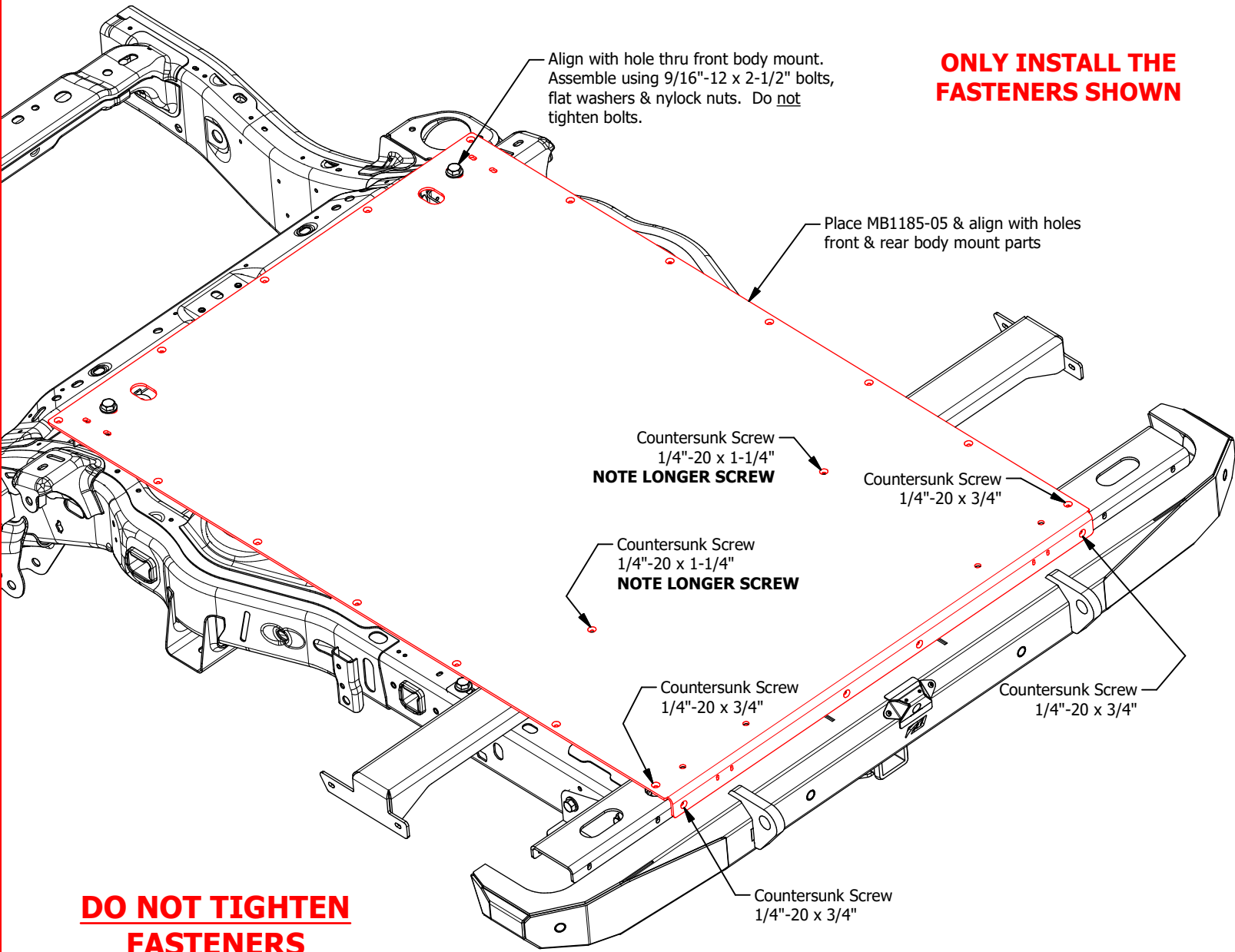

BAG LABELED AS
1185-KIT01
BAG LABELED AS
1185-KIT02

MB1185 - Assembly Instructions JT Gladiator Long Bed

BED ASSEMBLY STEP 3

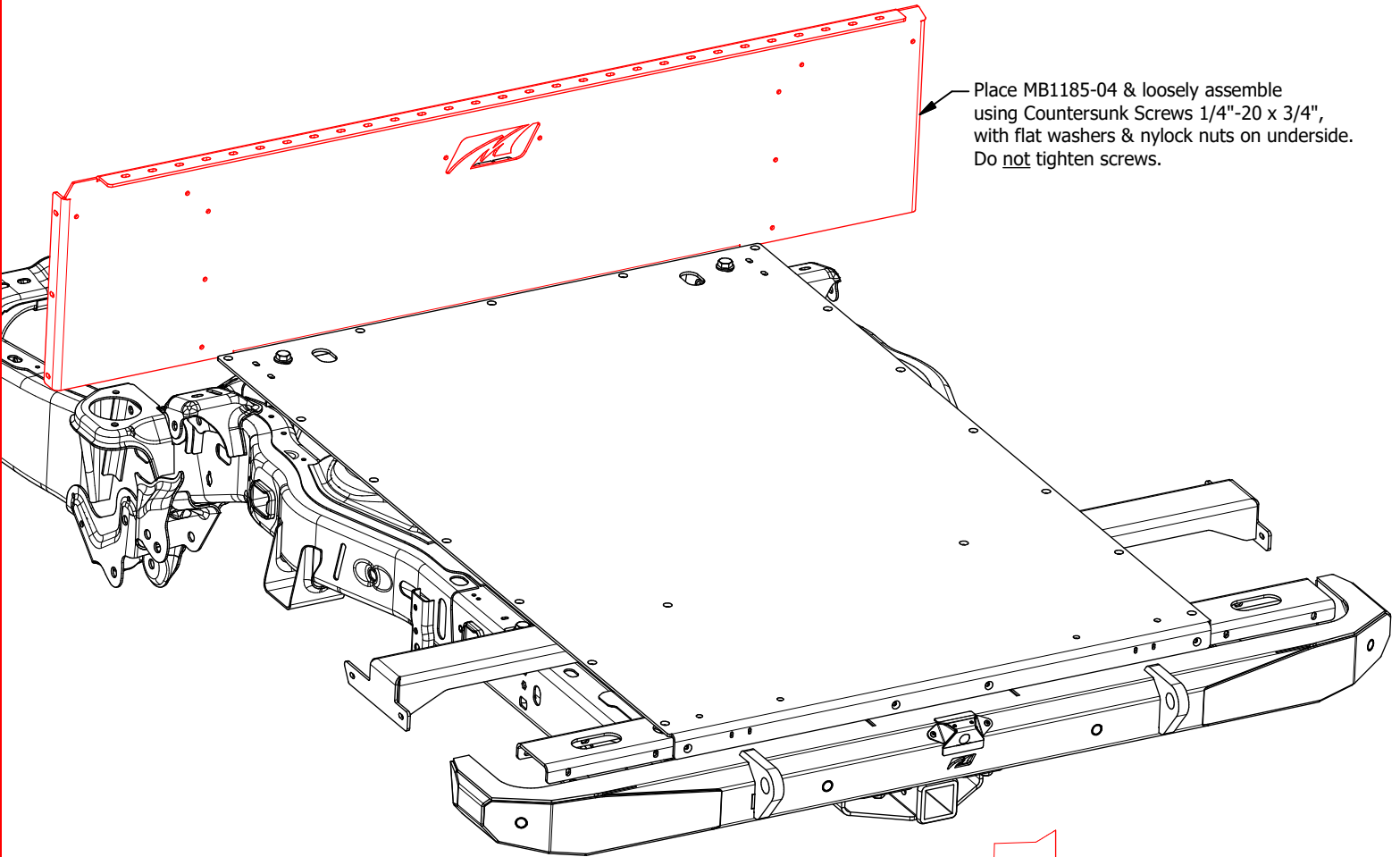

DO NOT TIGHTEN FASTENERS

Position flange under floor plate

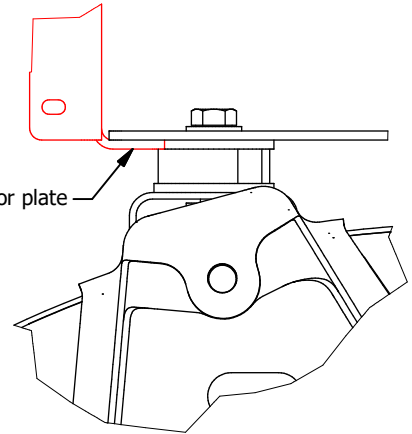

DETAIL D

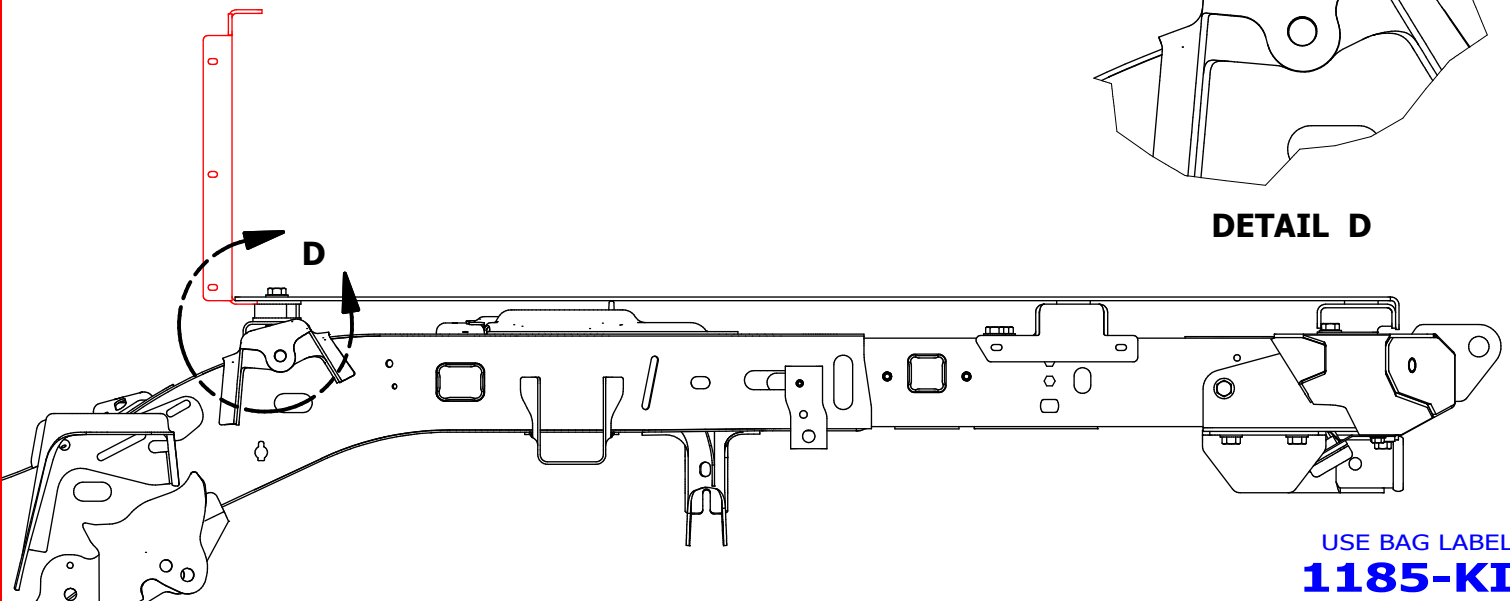

USE BAG LABELED AS
1185-KIT02

MB1185 - Assembly Instructions JT Gladiator Long Bed

BED ASSEMBLY STEP 4

**REPEAT STEPS ON
OPPOSITE SIDE
FOR DRIVER INNER
FENDER**

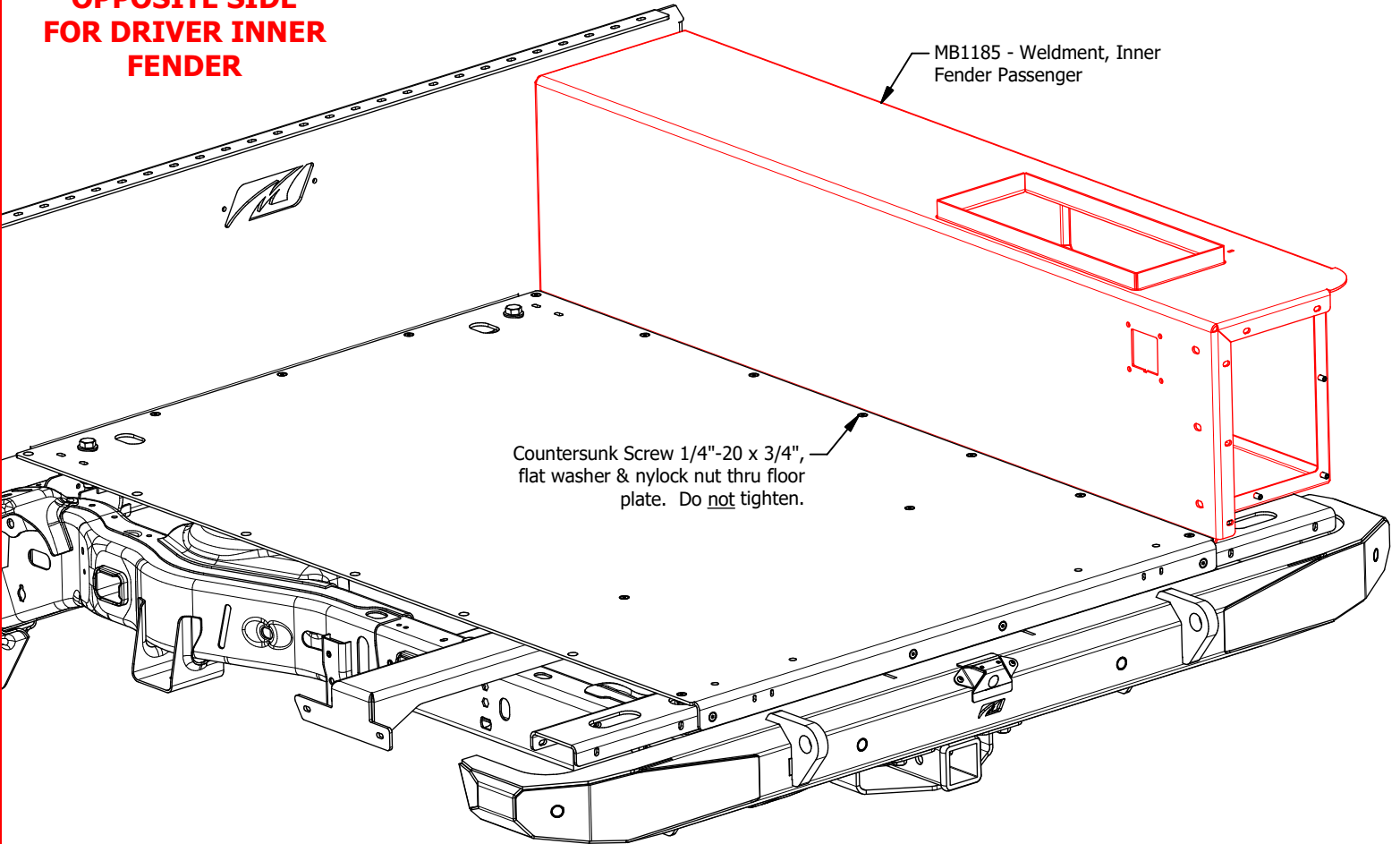

**DO NOT TIGHTEN
FASTENERS**

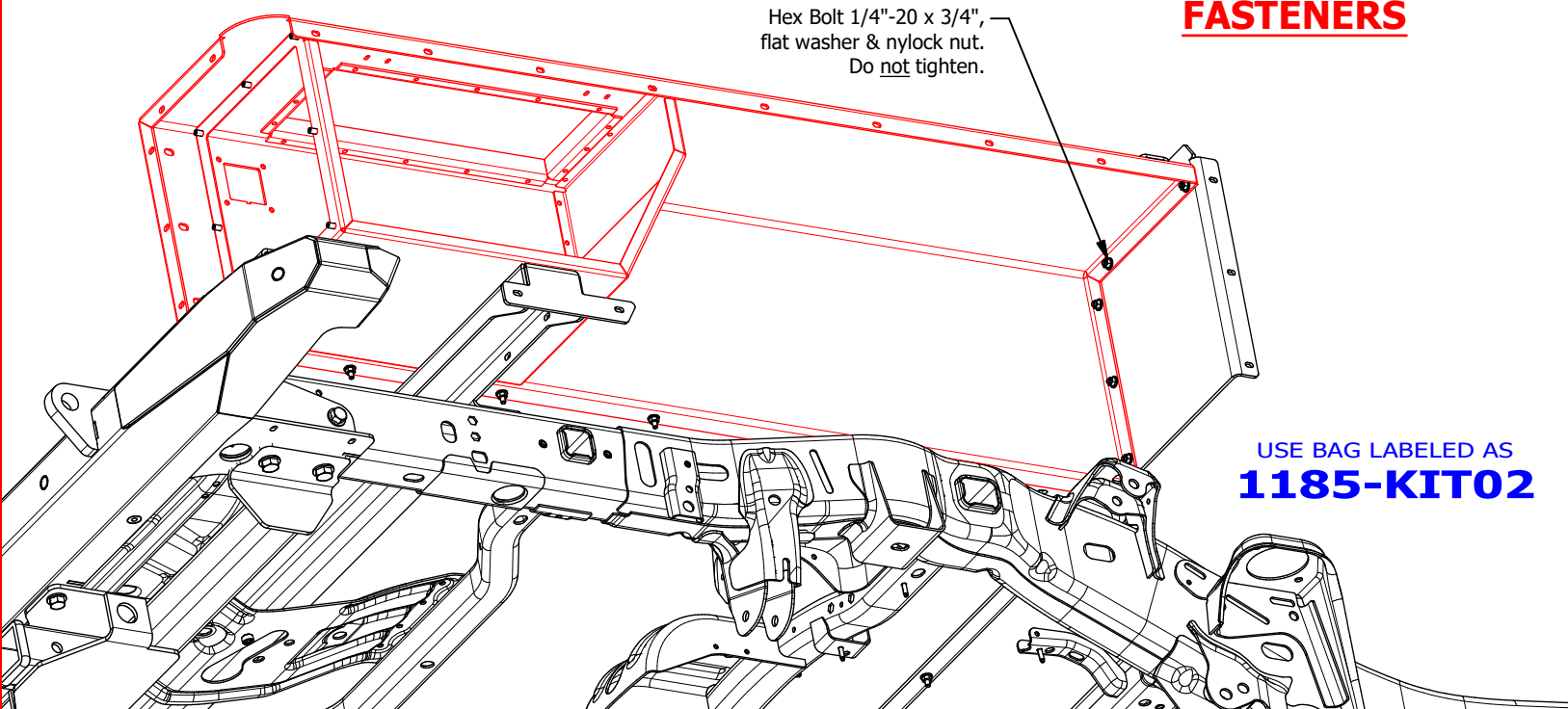

USE BAG LABELED AS
1185-KIT02

MB1185 - Assembly Instructions JT Gladiator Long Bed

BED ASSEMBLY STEP 5

**REPEAT STEPS ON
OPPOSITE SIDE
FOR DRIVER OUTER
FENDER**

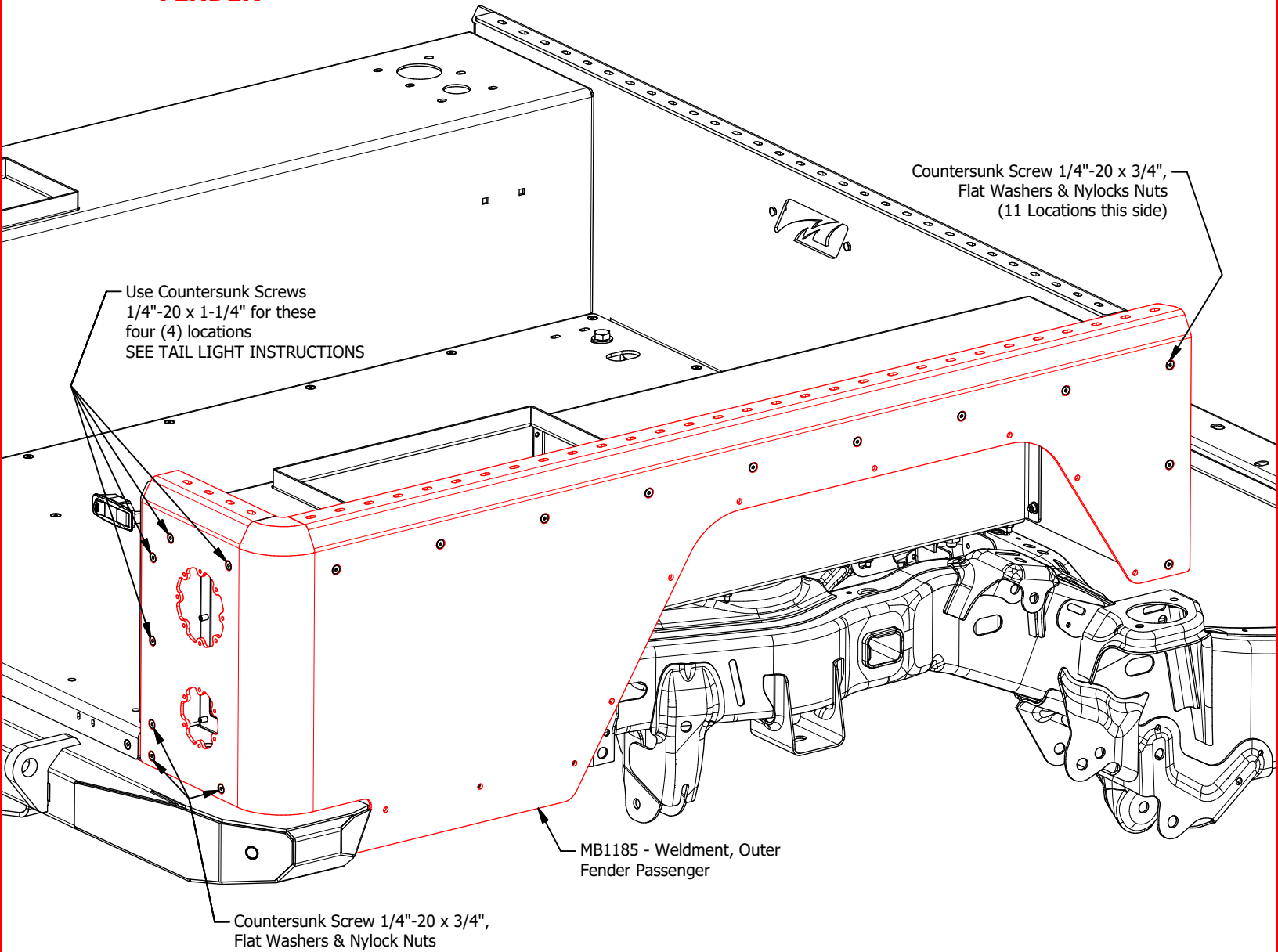

**DO NOT TIGHTEN
FASTENERS**

USE BAG LABELED AS
1185-KIT02

MB1185 - Assembly Instructions JT Gladiator Long Bed

BED ASSEMBLY STEP 6

**SEE STEP 7 BEFORE
TIGHTENING FASTENERS**

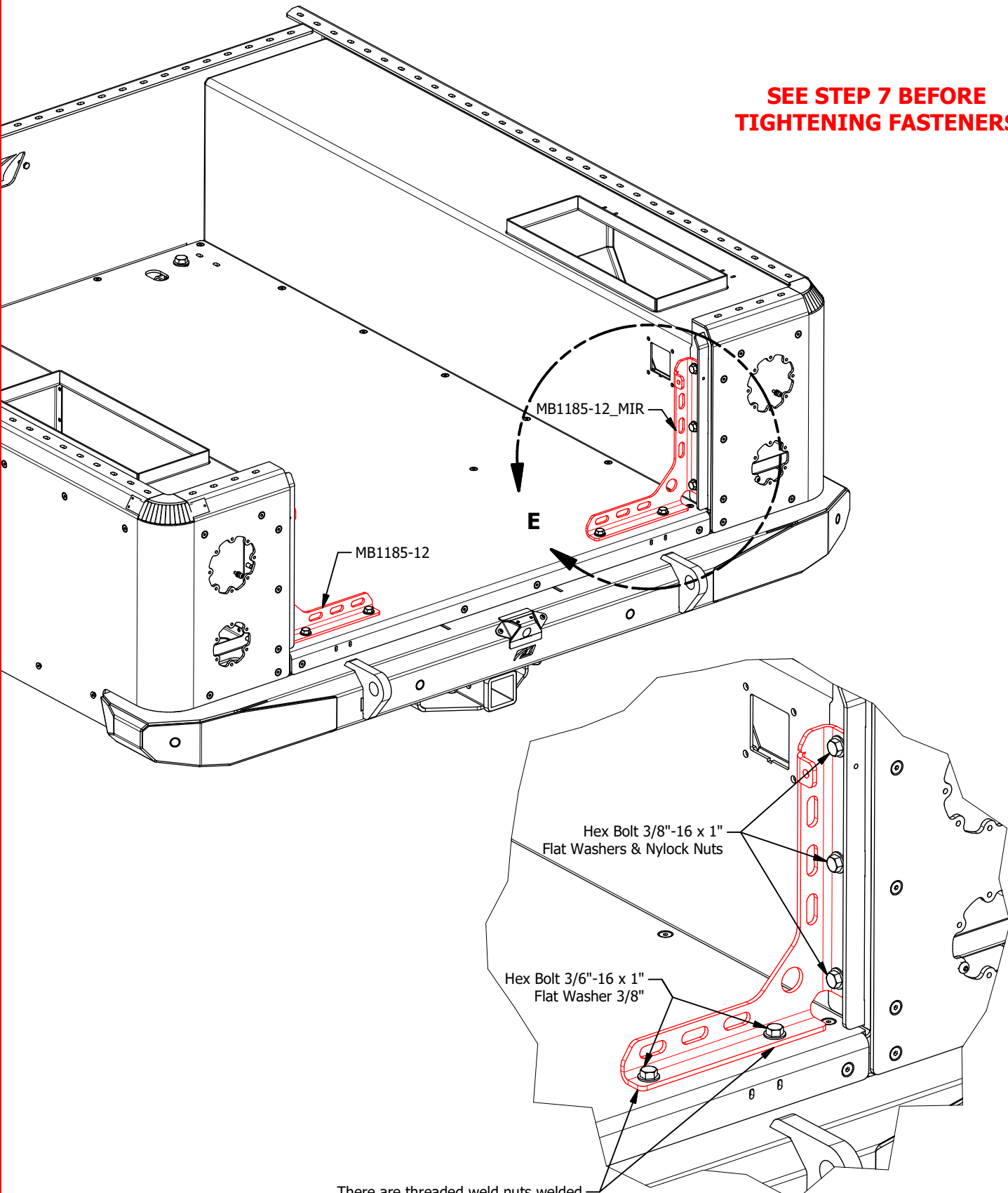

There are threaded weld nuts welded into the support structure below

DETAIL E

USE BAG LABELED AS
1185-KIT03

MB1185 - Assembly Instructions JT Gladiator Long Bed

BED ASSEMBLY STEP 7

HOW TO SQUARE THE TAILGATE OPENING

Place a ratchet strap between the tail light openings. Place a carpenter's square between the floor plate & vertical plate of the outer fender. Tighten ratchet strap until square. Check both the left & right fenders for square.

Tighten the 3/8" bolts for #MB1185-12 & #MB1185-12_MIR (from Step 07) starting with the bolts going through the floor plates, then the vertical bolts going through the outer & inner fenders.



Measure the lower inside distance between the outer fenders.

Measure the upper inside distance between the outer fenders.

If both measurements are equal & the outer fenders are square to the floor plate, then **tighten all fasteners installed up to this point.**

If both measurements are NOT equal, then you will need to check your squaring from above & adjust accordingly.

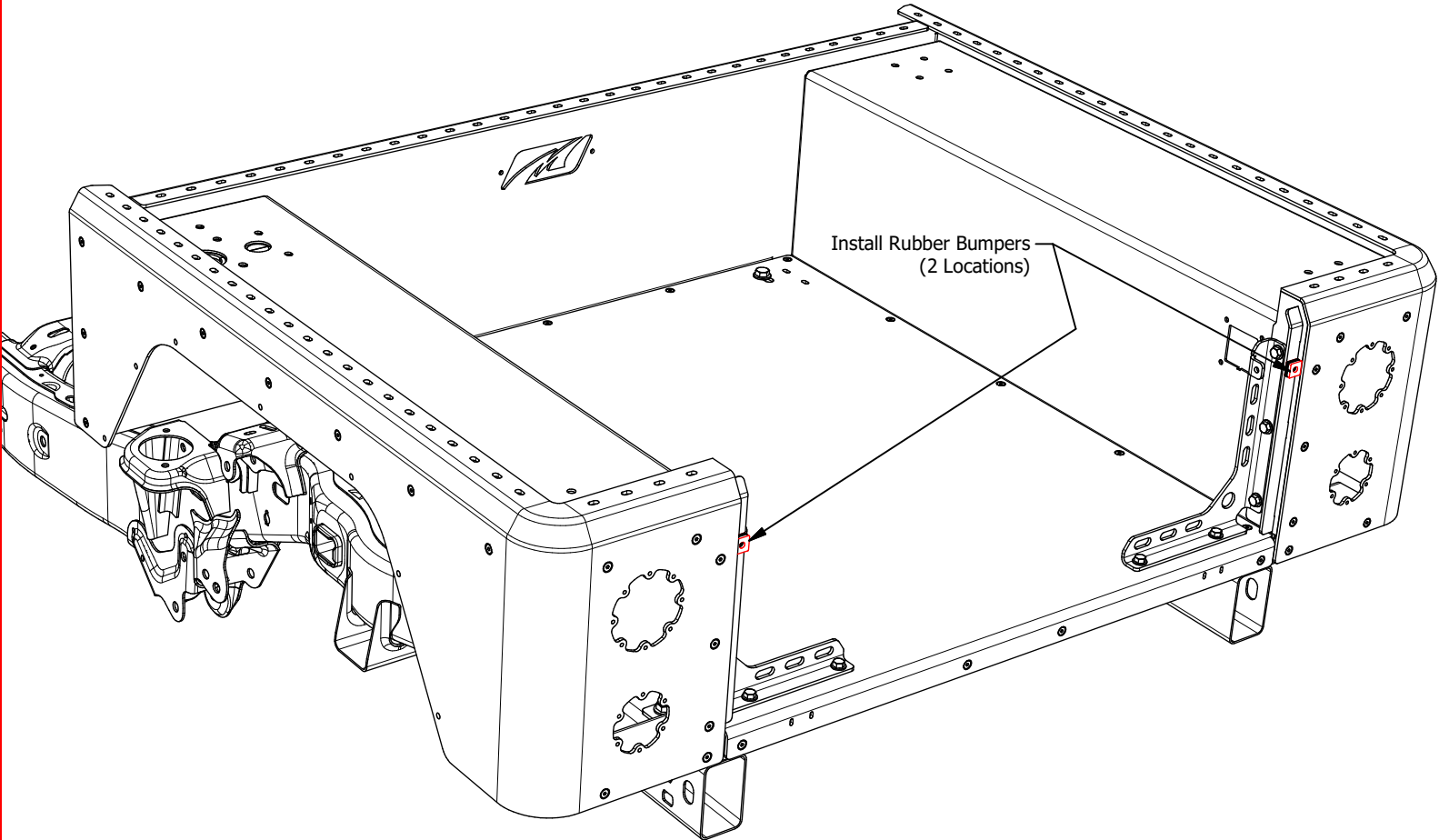

MB1185 - Assembly Instructions JT Gladiator Long Bed**BED ASSEMBLY STEP 8**

**TIGHTEN
FASTENERS**

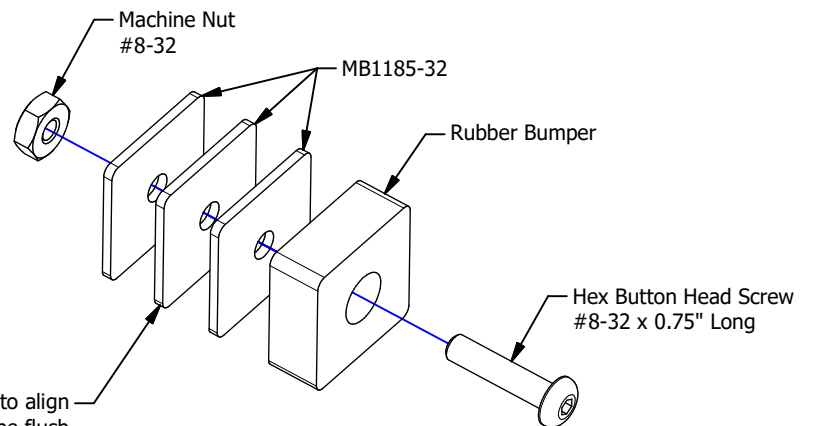

Use as many spacers as you need to align the outside edge of the tail gate to be flush with outside edge of the rear outer fenders.

USE BAG LABELED AS
1185-KIT04

MB1185 - Assembly Instructions JT Gladiator Long Bed

BED ASSEMBLY STEP 9

Place the Tailgate MB1185-02 in the opening. Clamp so the top edge of Tailgate is flush with the top of the outer fenders (see photo). Driver side shown. Repeat for passenger side.

Adjust the Tailgate left or right until the reveal between the Tailgate & the fenders are equal on both sides.

Install Tailgate hinges & fasteners. Tighten all fasteners for hinges.

Test function of hinges by opening the Tailgate. Adjust hinges if necessary.

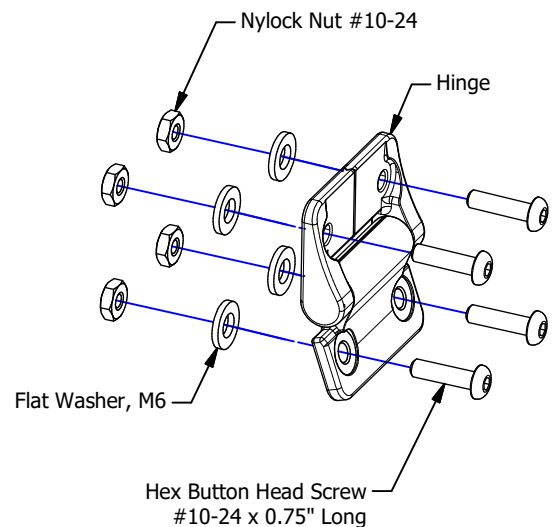

**TIGHTEN
FASTENERS**

USE BAG LABELED AS
1185-KIT05

MB1185 - Assembly Instructions JT Gladiator Long Bed

BED ASSEMBLY STEP 10

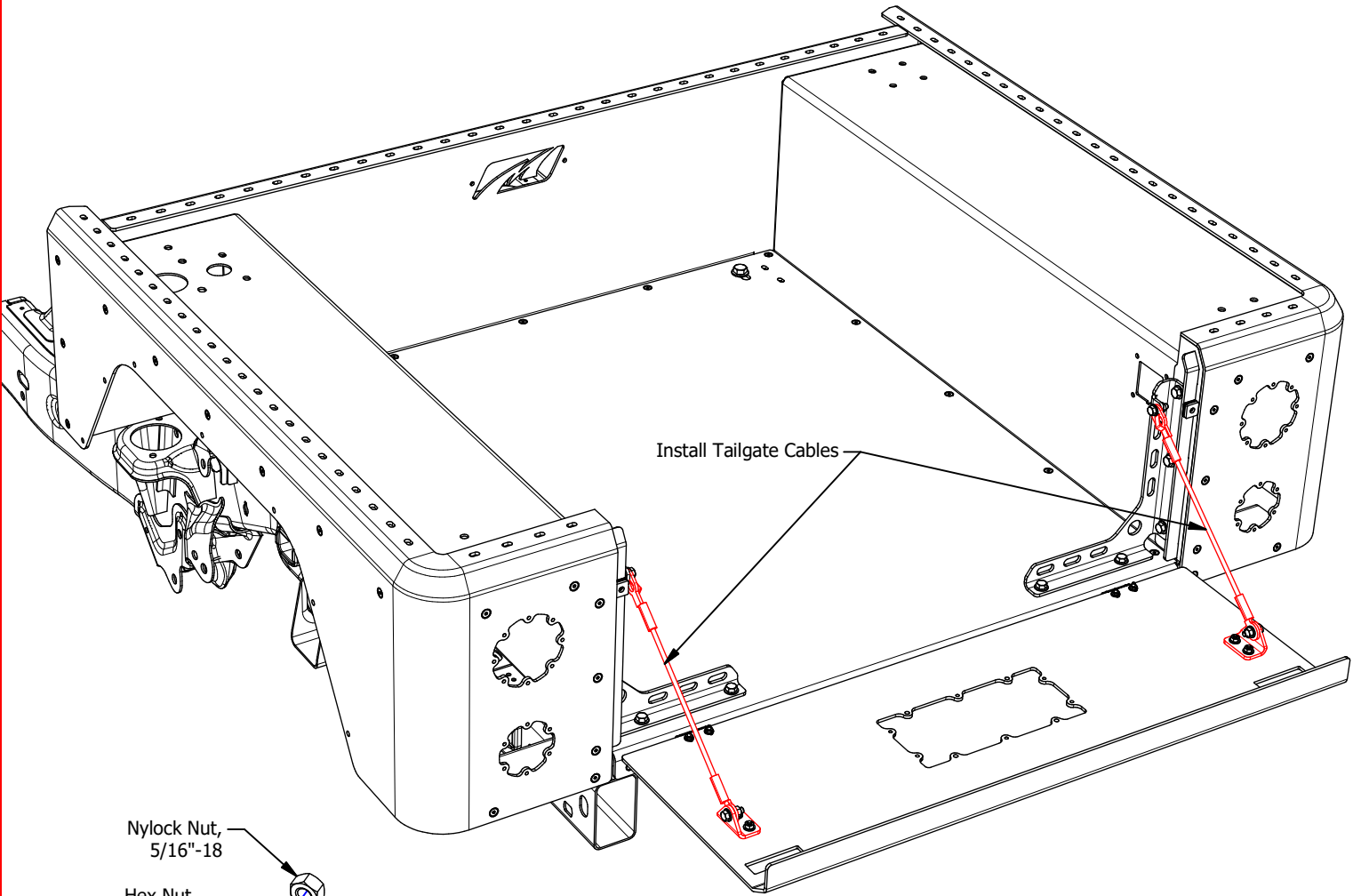

- Nylock Nut, 5/16"-18
- Hex Nut, 5/16"-18
- Flat Washer, 5/16"
- Hex Bolt, 5/16"-18 x 1"

NOTE:
Install Hex Nut first, then Nylock Nut second. Ensure cable can still pivot, then tighten both nuts together.

Tailgate Cable

- Nylock Nut, 1/4"-20
- Hex Bolt, 5/16"-18 x 1"
- Flat Washer, 5/16"
- Flat Washer, 1/4"
- MB1185-26
- MB1186-25 Cable Eye Spacer
- Countersunk Screw, 1/4"-20 x 3/4"
- Flat Washer, 5/16"
- Nylock Nut, 5/16"-18

TIGHTEN FASTENERS

Tailgate Cable Assembly (2 Locations)

USE BAG LABELED AS
1185-KIT06

MB1185 - Assembly Instructions JT Gladiator Long Bed

BED ASSEMBLY STEP 11

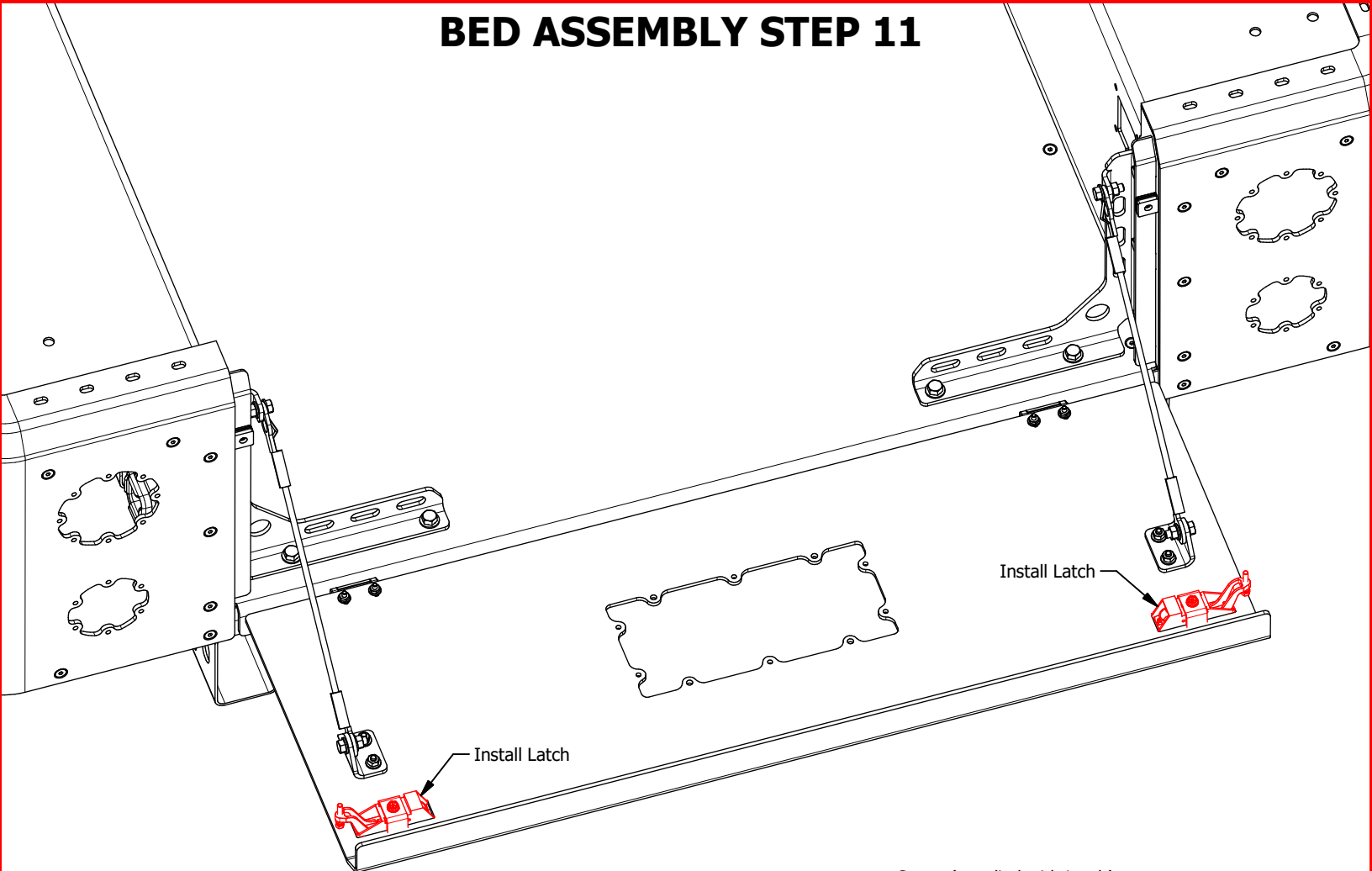

**TIGHTEN
FASTENERS**

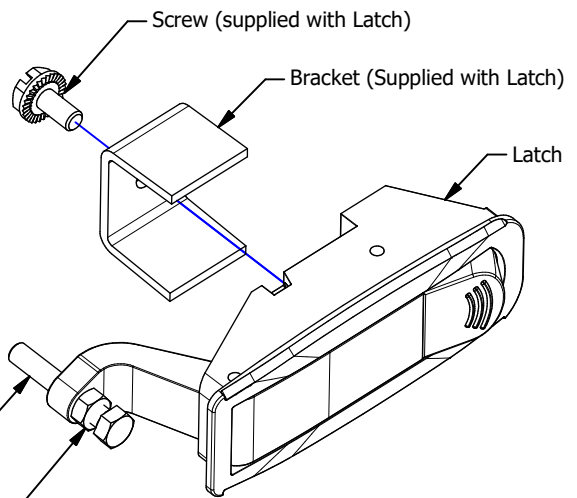

With Tailgate closed, adjust this bolt to increase or decrease tension between Tailgate & Bed.

Once latch is adjusted, tighten this nut to secure bolt in place.

**Push Latch
(2 Locations)**

USE BAG LABELED AS
1185-KIT07

MB1185 - Assembly Instructions JT Gladiator Long Bed

BED ASSEMBLY STEP 12

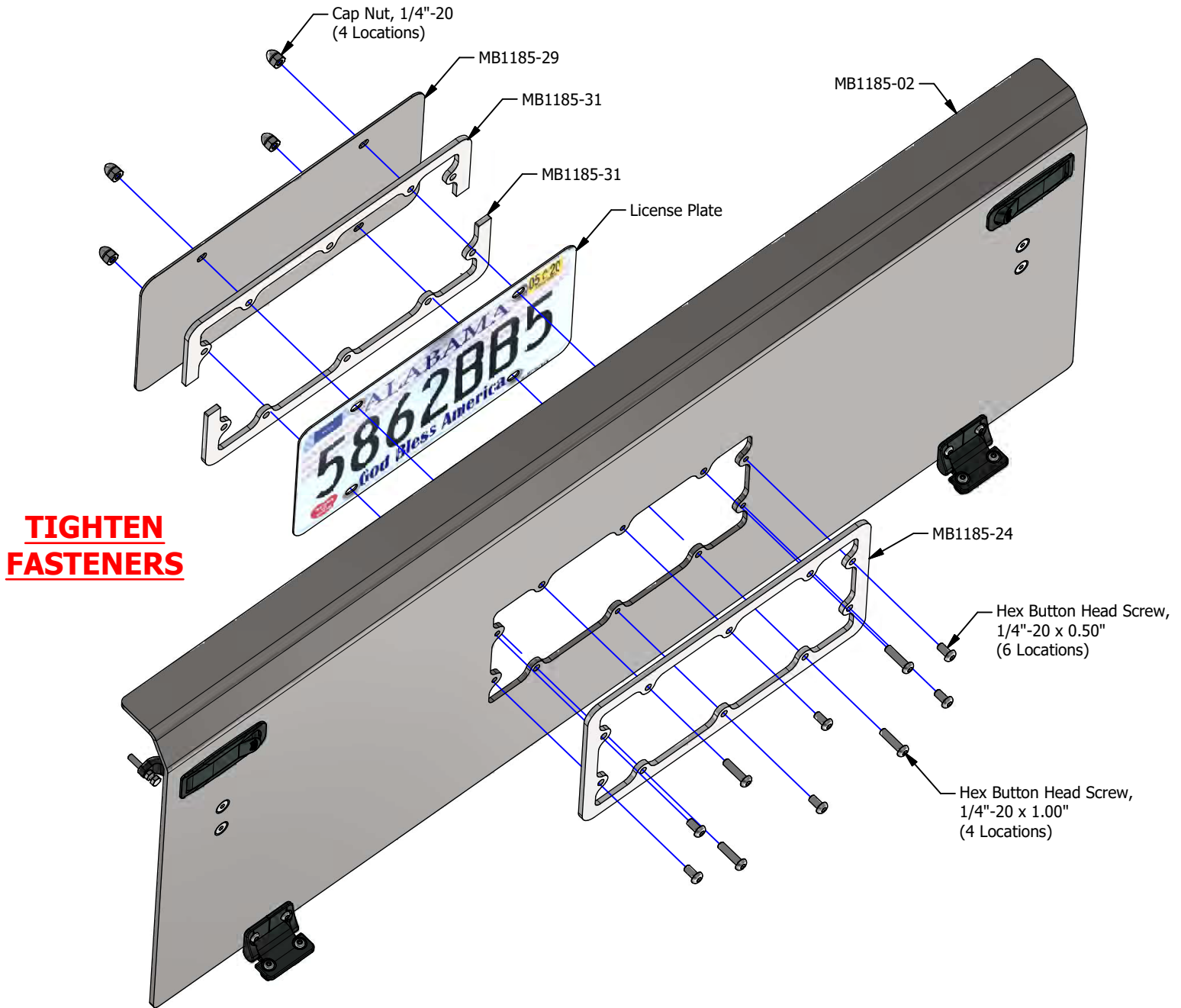

License Plate Assembly

USE BAG LABELED AS
1185-KIT08

MB1185 - Assembly Instructions JT Gladiator Long Bed

BED ASSEMBLY STEP 13

NOTE: These fasteners bolt through the outer fender to the inner fender. Add the nylock nut to the countersunk screw to secure the fenders together. This nut will also act as a spacer for MB1185-22. The countersunk screw is extra long. Place MB1185-22 over the extended portion of the screw then fasten with the flat washer & nylock nut.

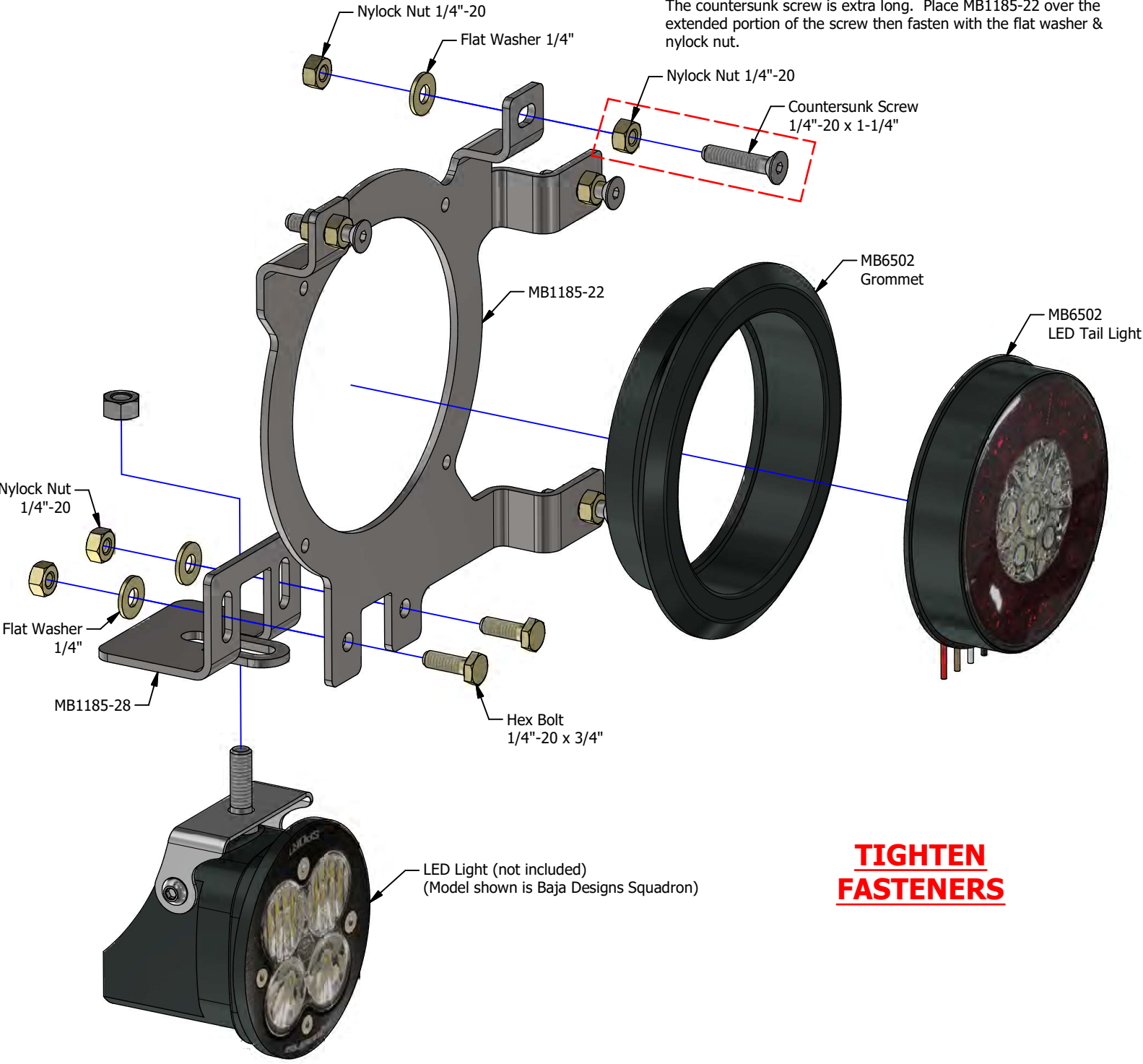

TIGHTEN FASTENERS

USE BAG LABELED AS
1185-KIT09
 USE BAG LABELED AS
1185-KIT17

MB1185 - Assembly Instructions JT Gladiator Long Bed

BED ASSEMBLY STEP 14

NOTE: These fasteners bolt through the outer fender to the inner fender. Add the nylock nut to the countersunk screw to secure the fenders together. This nut will also act as a spacer for MB1185-22. The countersunk screw is extra long. Place MB1185-22 over the extended portion of the screw then fasten with the flat washer & nylock nut.

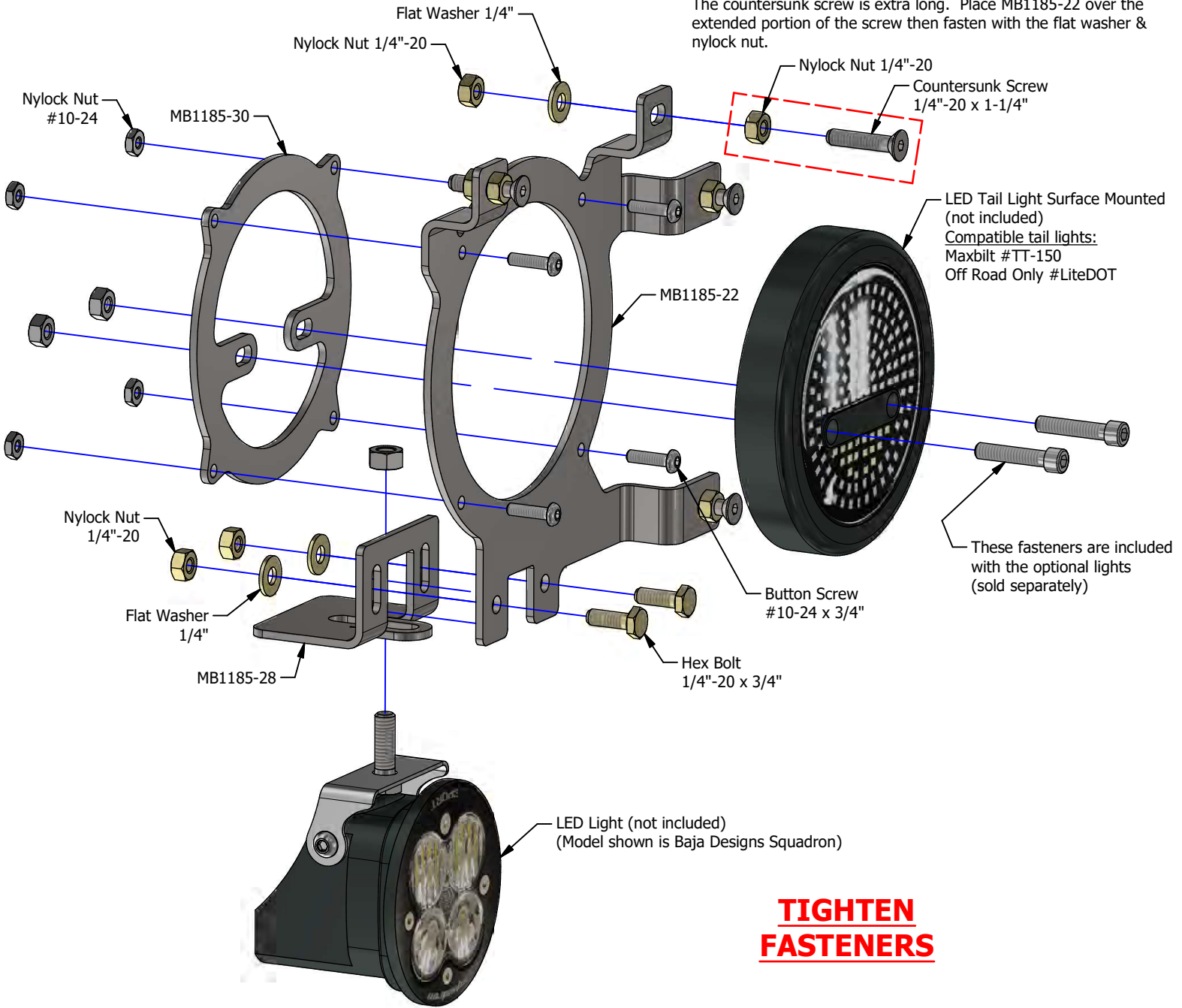

TIGHTEN FASTENERS

ALTERNATE LIGHT MOUNTING

USE BAG LABELED AS
1185-KIT09
 USE BAG LABELED AS
1185-KIT17

MB1185 - Assembly Instructions JT Gladiator Long Bed

BED ASSEMBLY STEP 15

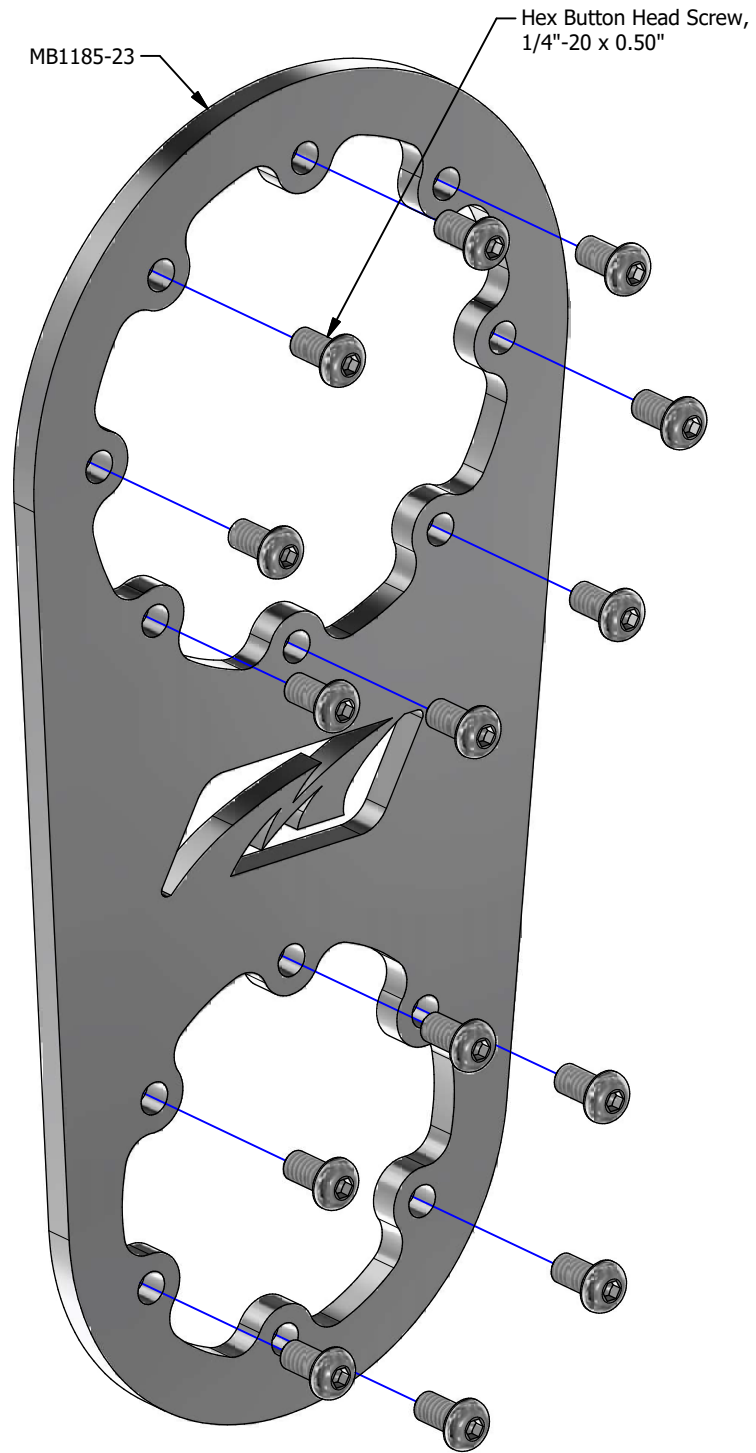
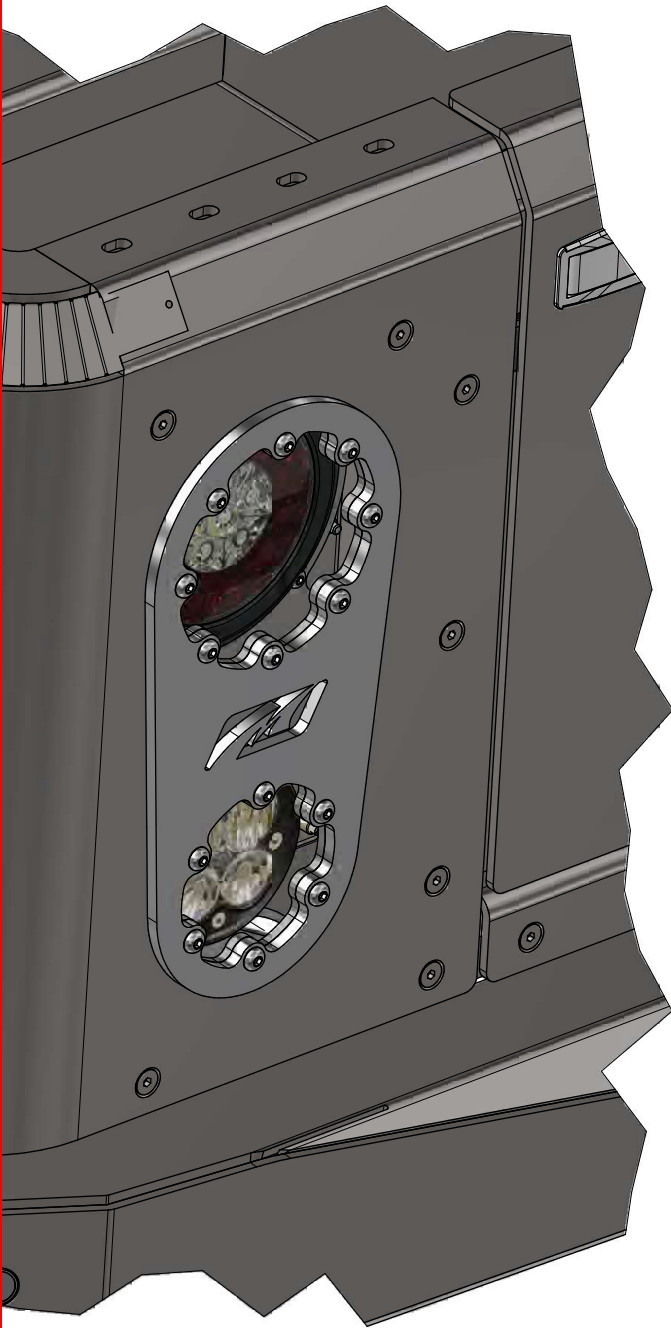

TIGHTEN
FASTENERS

EXTERIOR TAIL LIGHT TRIM ASSEMBLY
2 LOCATIONS

USE BAG LABELED AS
1185-KIT10

MB1185 - Assembly Instructions JT Gladiator Long Bed

BED ASSEMBLY STEP 16

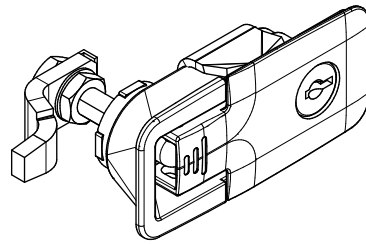

**Locking Latch
Qty 2**

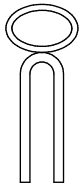

Install Bulb Seals

MB1185-47

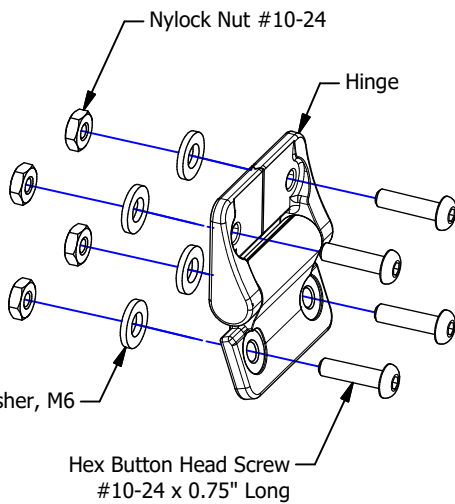

**TIGHTEN
FASTENERS**

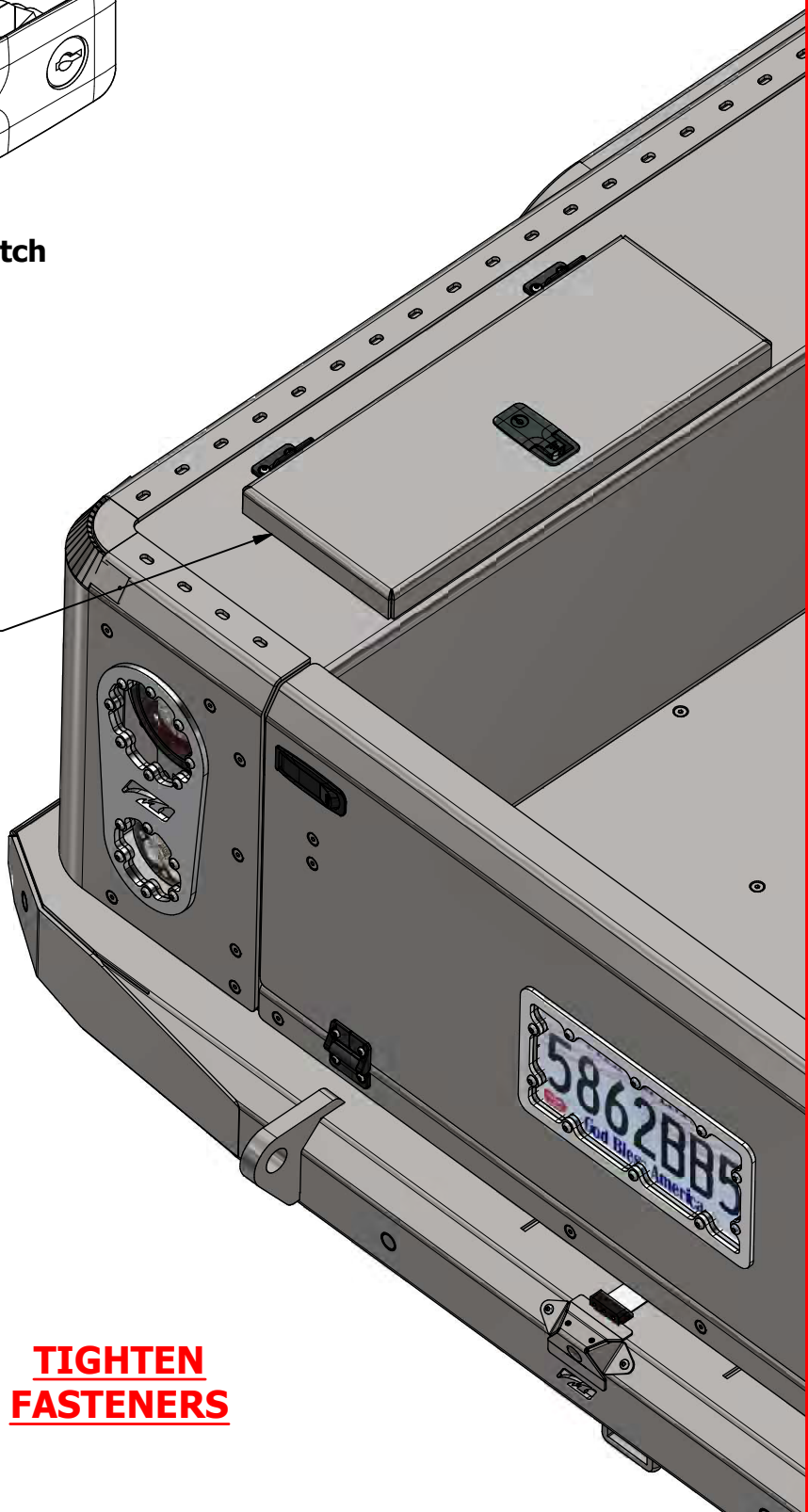

MB1185 - Assembly Instructions JT Gladiator Long Bed

BED ASSEMBLY STEP 17

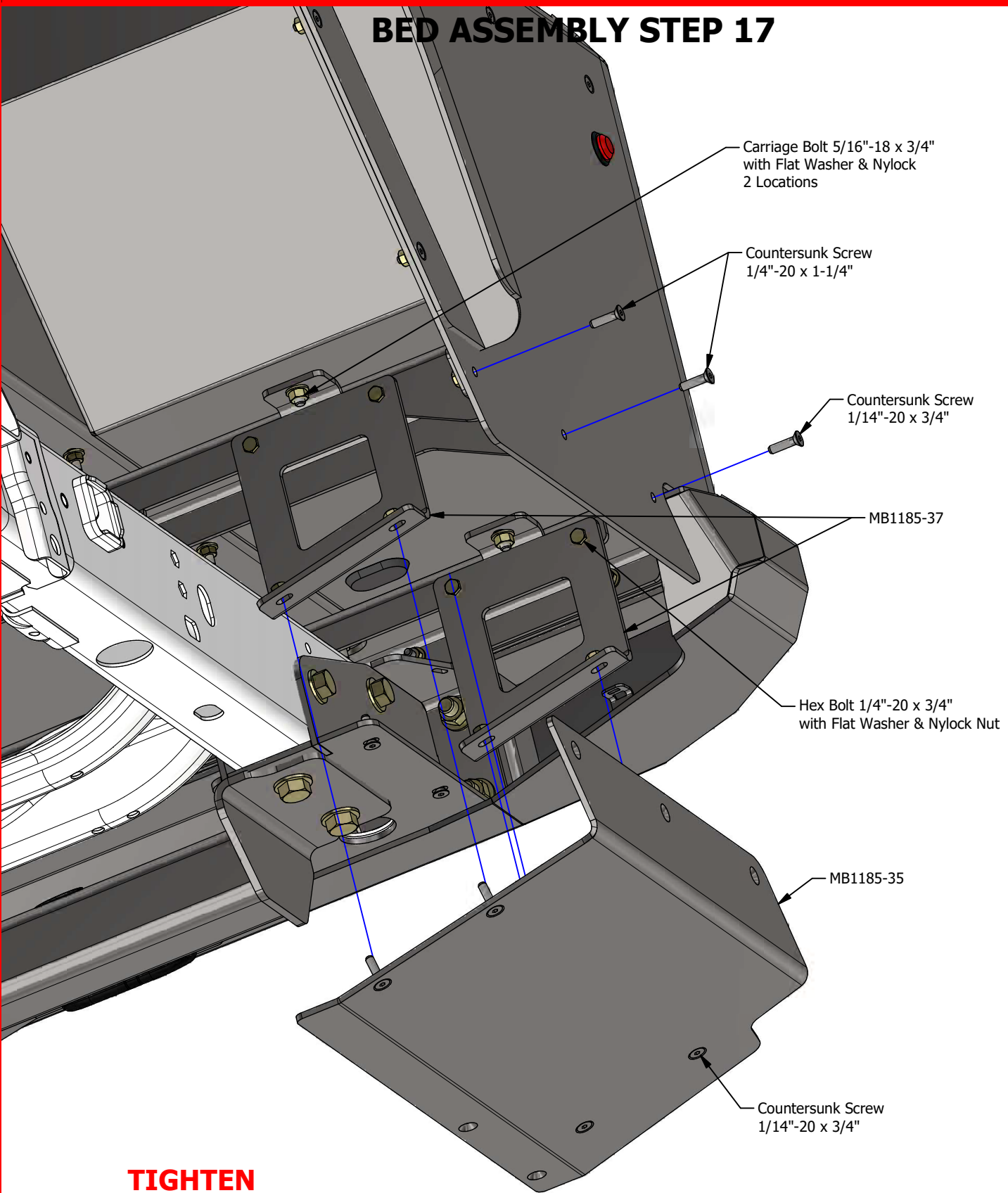

**TIGHTEN
FASTENERS**

BAG LABELED AS
1185-KIT02
BAG LABELED AS
1185-KIT13

MB1185 - Assembly Instructions JT Gladiator Long Bed

BED ASSEMBLY STEP 18

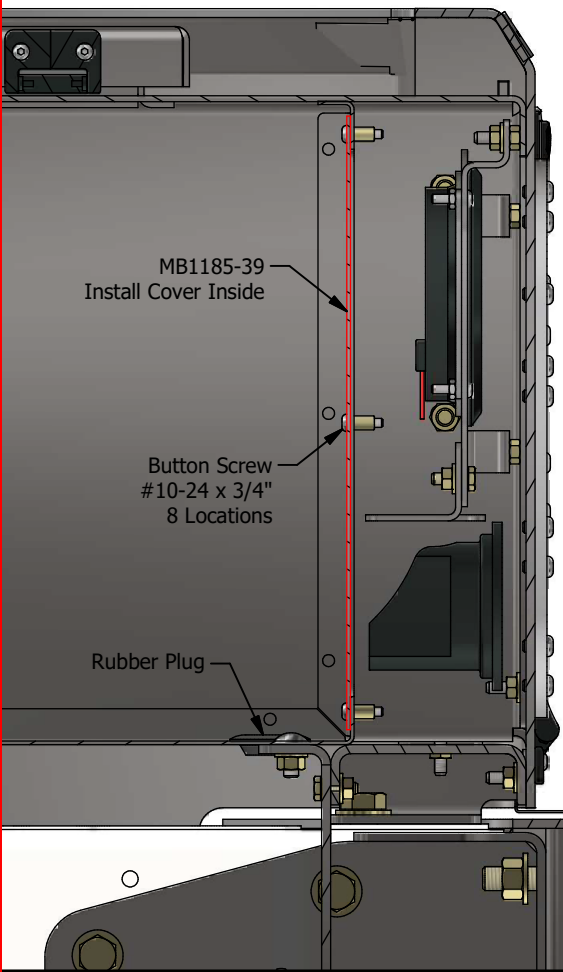

**MB1185-39
Qty 2**



**Rubber Plug
Qty 2**

**TIGHTEN
FASTENERS**

BAG LABELED AS
1185-KIT13

BED ASSEMBLY STEP 19



**Rubber Plug
Qty 2**



MB1185 - Assembly Instructions JT Gladiator Long Bed

FUEL FILLER ARRANGEMENTS

STEP 20

This kit includes provisions for installing either a GASOLINE fuel filler or a DIESEL fuel filler with DEF filler tube & DEF cap. You will reuse and/or modify the factory fuel filler components for both fuel filler arrangements.

If you have a GASOLINE fuel vehicle, use the sections named "GASOLINE ARRANGEMENT". The 1185-KIT12 & 1185-KIT13 in the CONTENTS sections denotes GASOLINE compatible components as shown in RED. Components shown in BLACK are common to both GASOLINE or DIESEL & will be used for either arrangement.

If you have a DIESEL fuel vehicle, use the sections named "DIESEL ARRANGEMENT". The 1185-KIT12 & 1185-KIT13 in the CONTENTS sections denotes DIESEL compatible components as shown in GREEN. Components shown in BLACK are common to both GASOLINE or DIESEL & will be used for either arrangement.

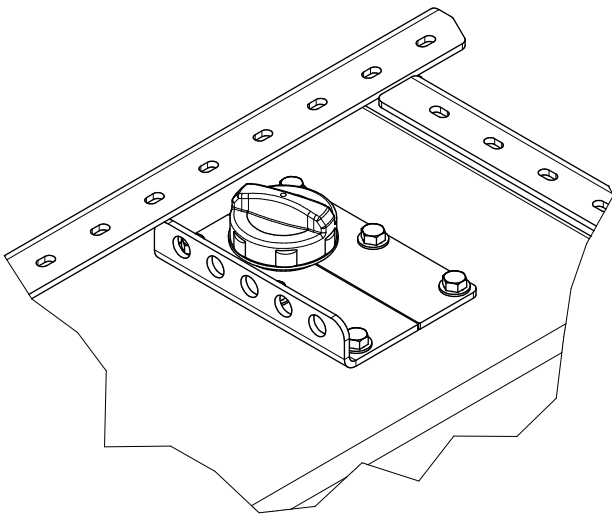
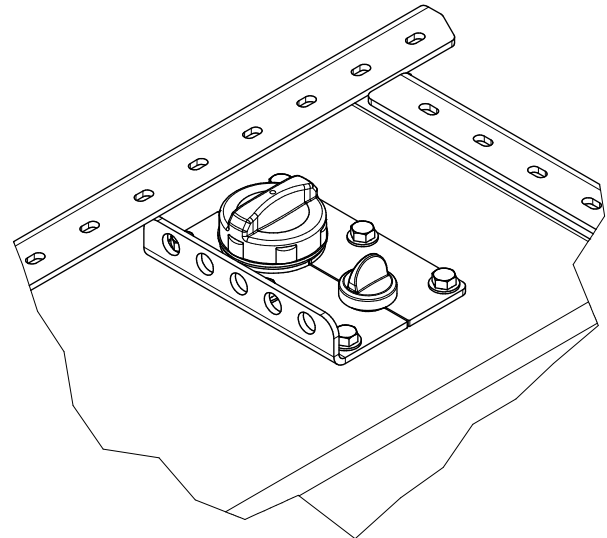
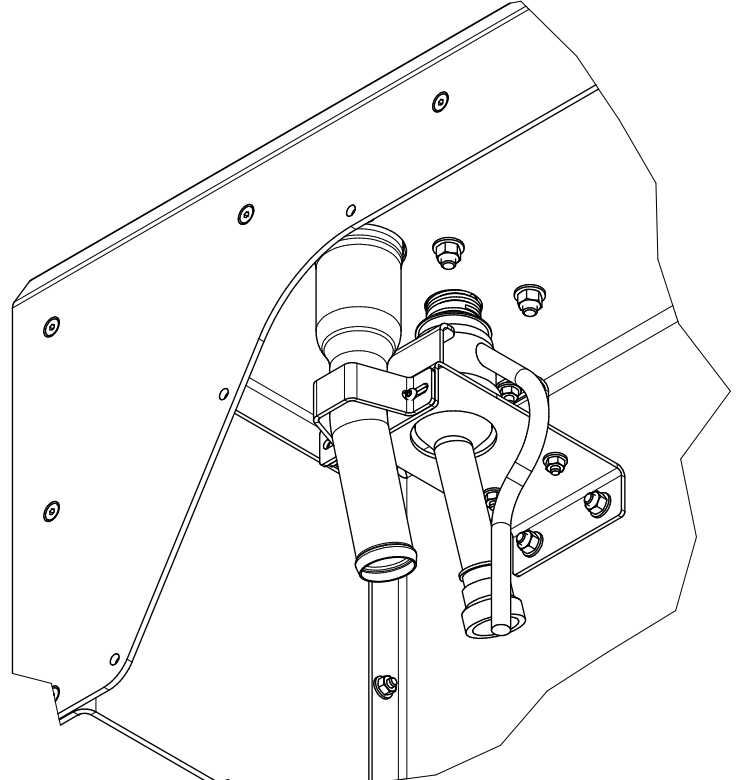
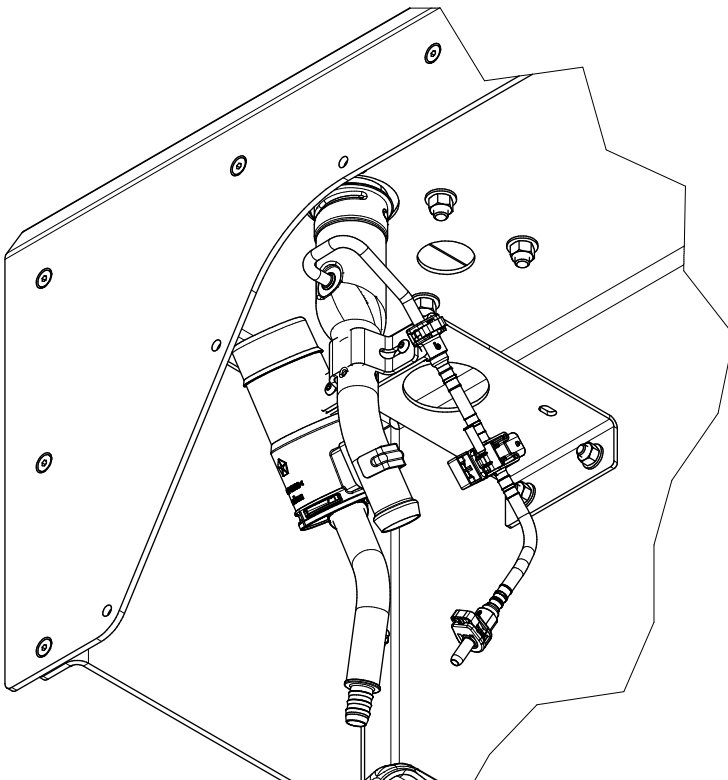
GASOLINE ARRANGEMENT

DIESEL ARRANGEMENT

MB1185 - Assembly Instructions JT Gladiator Long Bed**GASOLINE ARRANGEMENT STEP 21
GAS FUEL FILLER MODIFICATION**

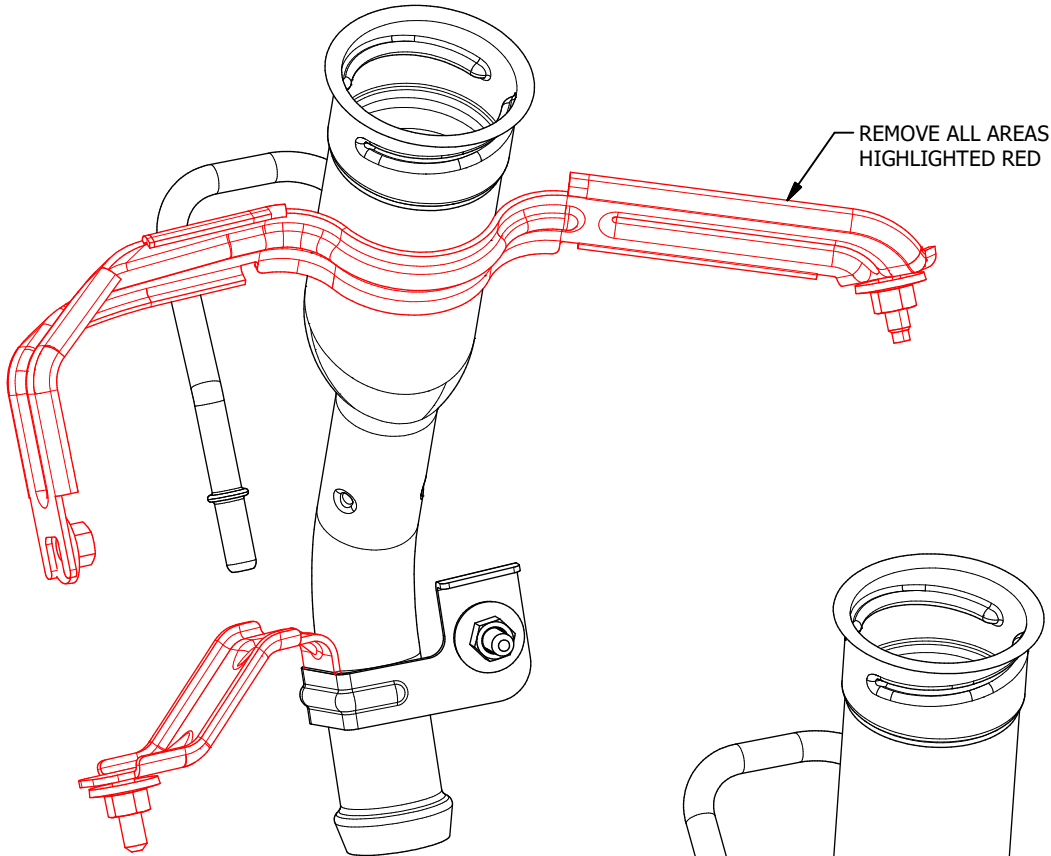
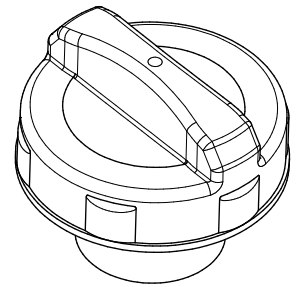
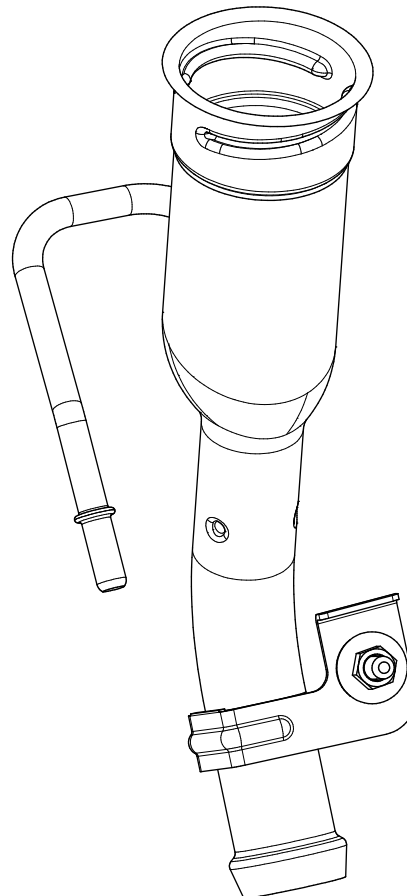
Disconnect the factory gasoline fuel filler from the factory filler hose. Cut off the brackets shown below. Ensure all cut edges are deburred & have no sharp edges.

**BEFORE****FACTORY GAS CAP****AFTER**

MB1185 - Assembly Instructions JT Gladiator Long Bed

GASOLINE ARRANGEMENT STEP 22

The fuel filler plates are split in half both on the topside. This is designed to support the modified factory fuel filler. The topside plates have a raised section welded to them. Place the raised section facing up. This provides the necessary support & spacing for the factory gas cap. The lower brackets mount inside the driver inner fender. The U-shaped clamp bracket supports the fuel filler neck.

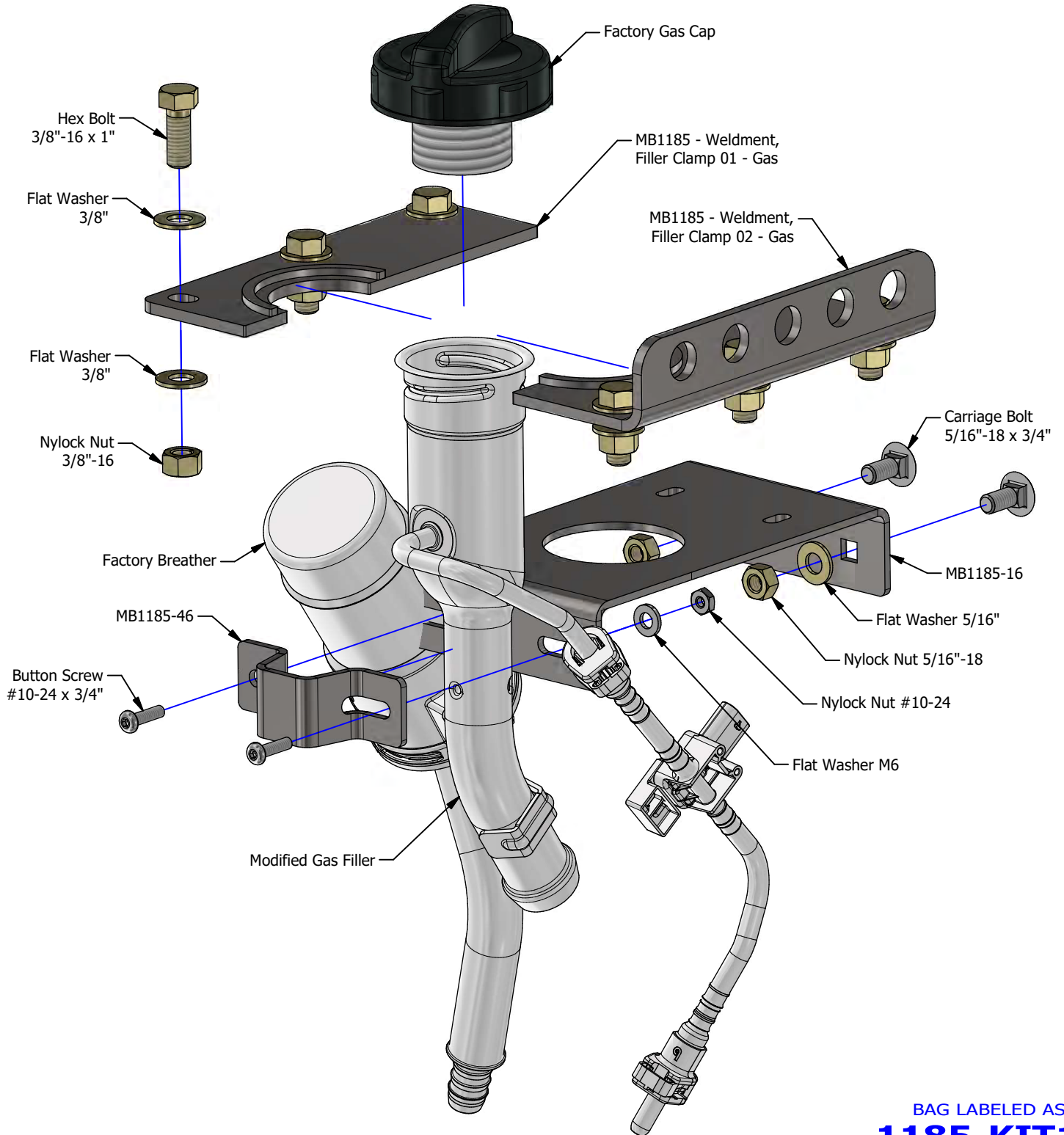

BAG LABELED AS
1185-KIT12
 BAG LABELED AS
1185-KIT13

MB1185 - Assembly Instructions JT Gladiator Long Bed

GASOLINE ARRANGEMENT STEP 23

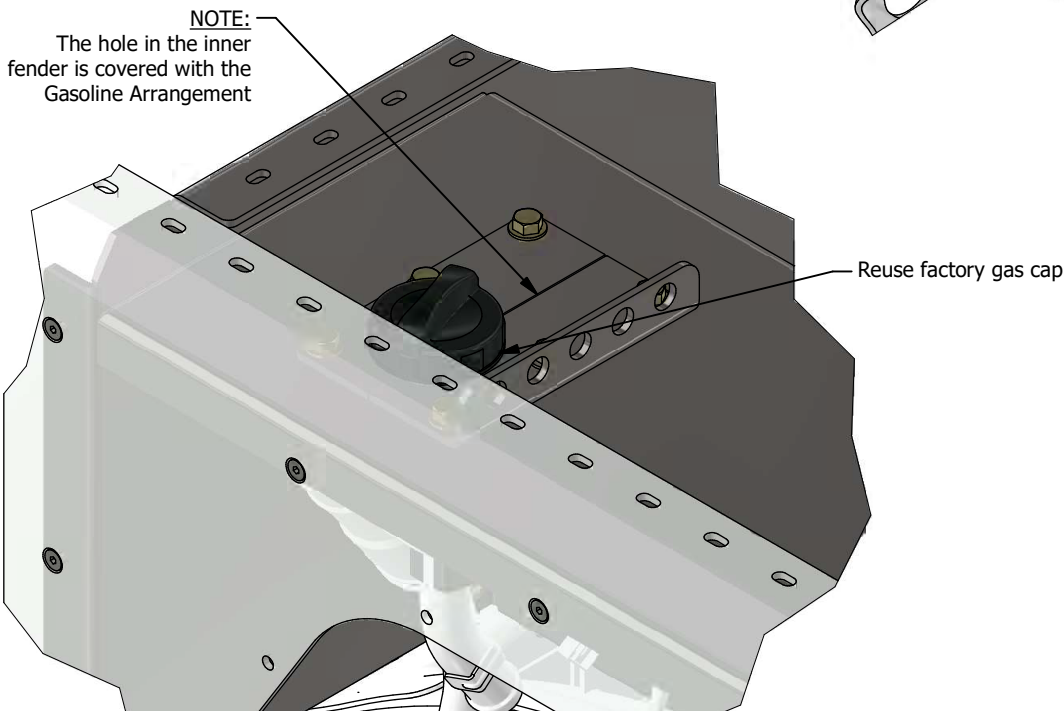
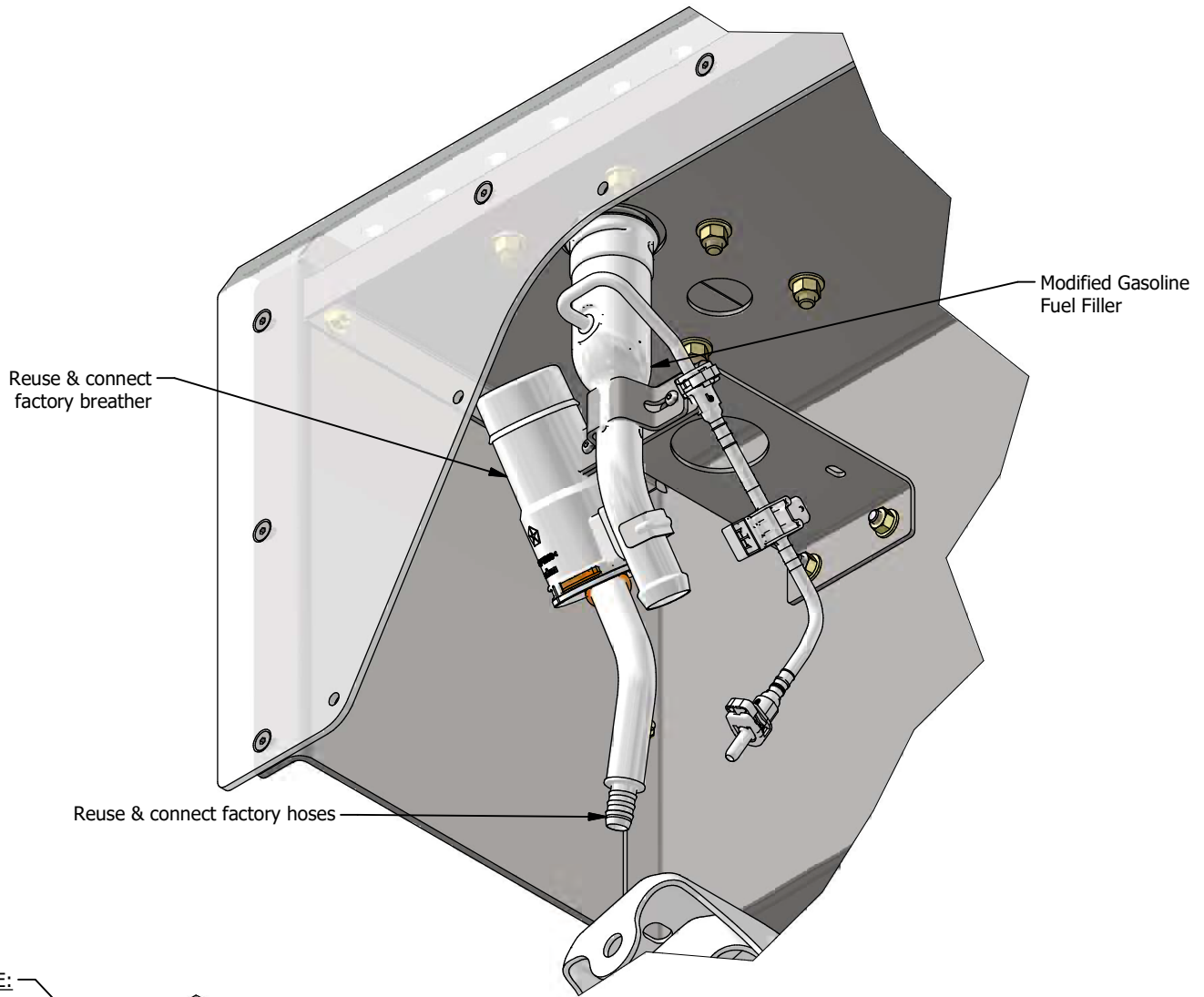

TIGHTEN
FASTENERS

USE BAG LABELED AS
1185-KIT12
USE BAG LABELED AS
1185-KIT13

MB1185 - Assembly Instructions JT Gladiator Long Bed**DIESEL ARRANGEMENT STEP 24
REUSE FACTORY DIESEL FUEL FILLER
& REUSE FACTORY DEF FILLER**

Disconnect the factory diesel fuel filler & the factory DEF filler from the factory filler hoses. No modification is needed.

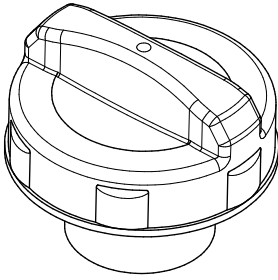
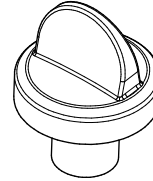
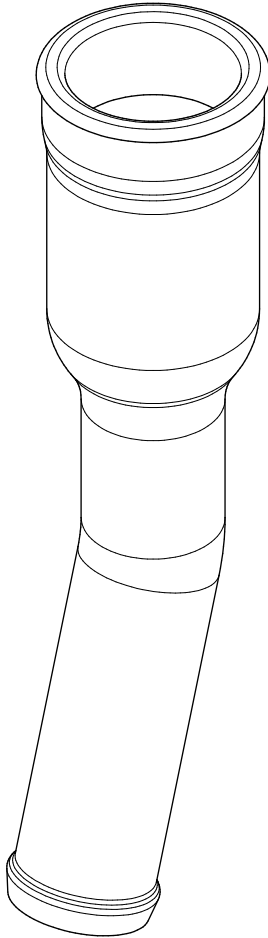
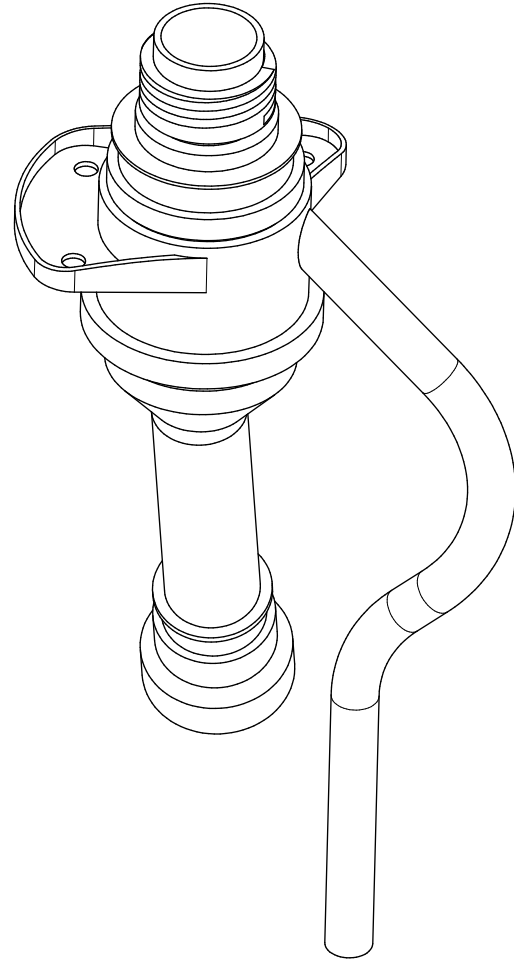
**FACTORY DIESEL CAP****FACTORY DEF CAP****FACTORY DIESEL FILLER****FACTORY DEF FILLER**

MB1185 - Assembly Instructions JT Gladiator Long Bed

DIESEL ARRANGEMENT STEP 25

The fuel filler plates are split in half both on the topside. This is designed to support the factory fuel filler. The topside plates have a raised section welded to them. Place the raised section facing up. This provides the necessary support & spacing for the factory diesel cap. The lower brackets mount inside the driver inner fender. The U-shaped clamp bracket supports the fuel filler neck.

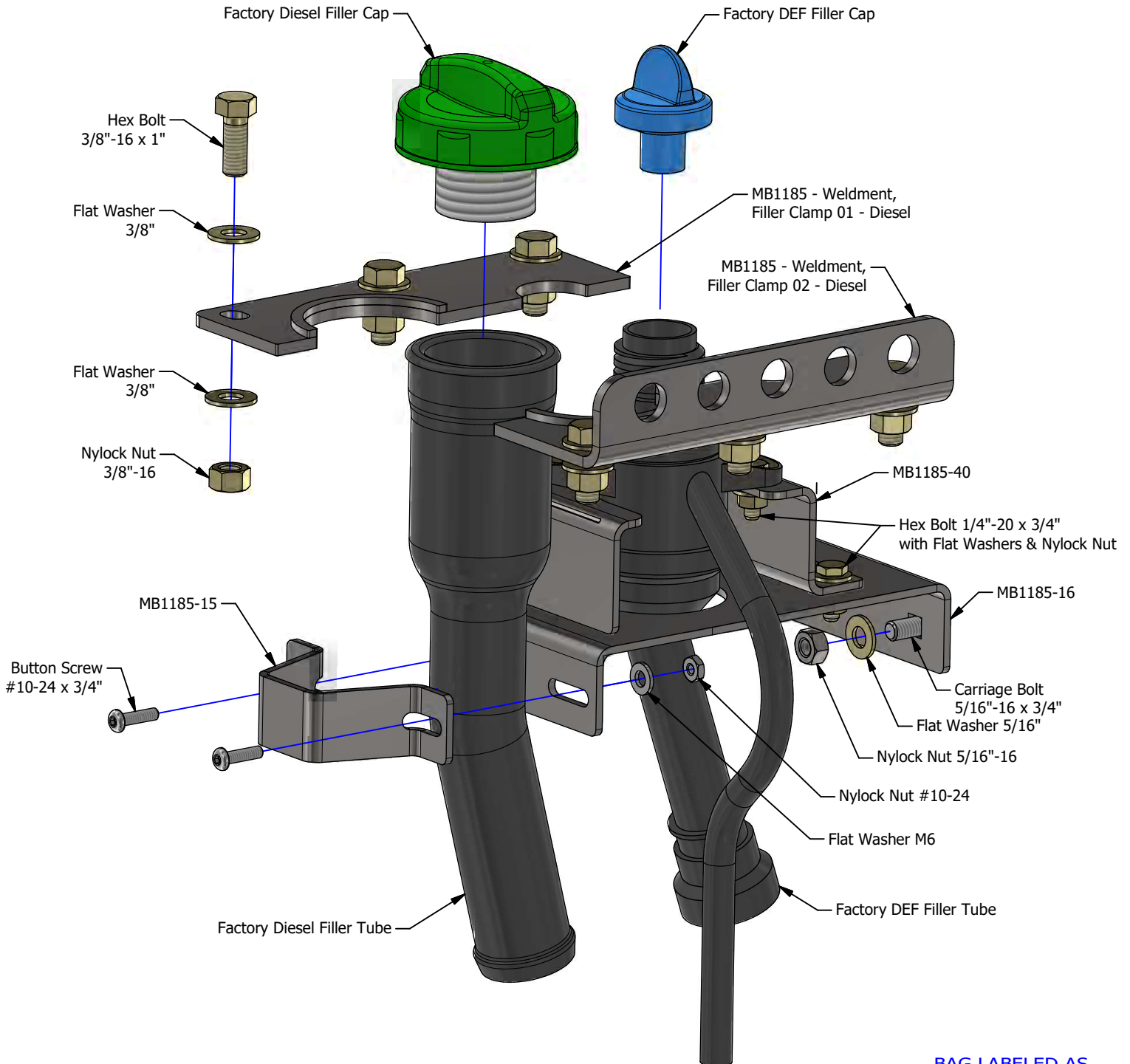

BAG LABELED AS
1185-KIT12
 BAG LABELED AS
1185-KIT13

MB1185 - Assembly Instructions JT Gladiator Long Bed

DIESEL ARRANGEMENT STEP 26

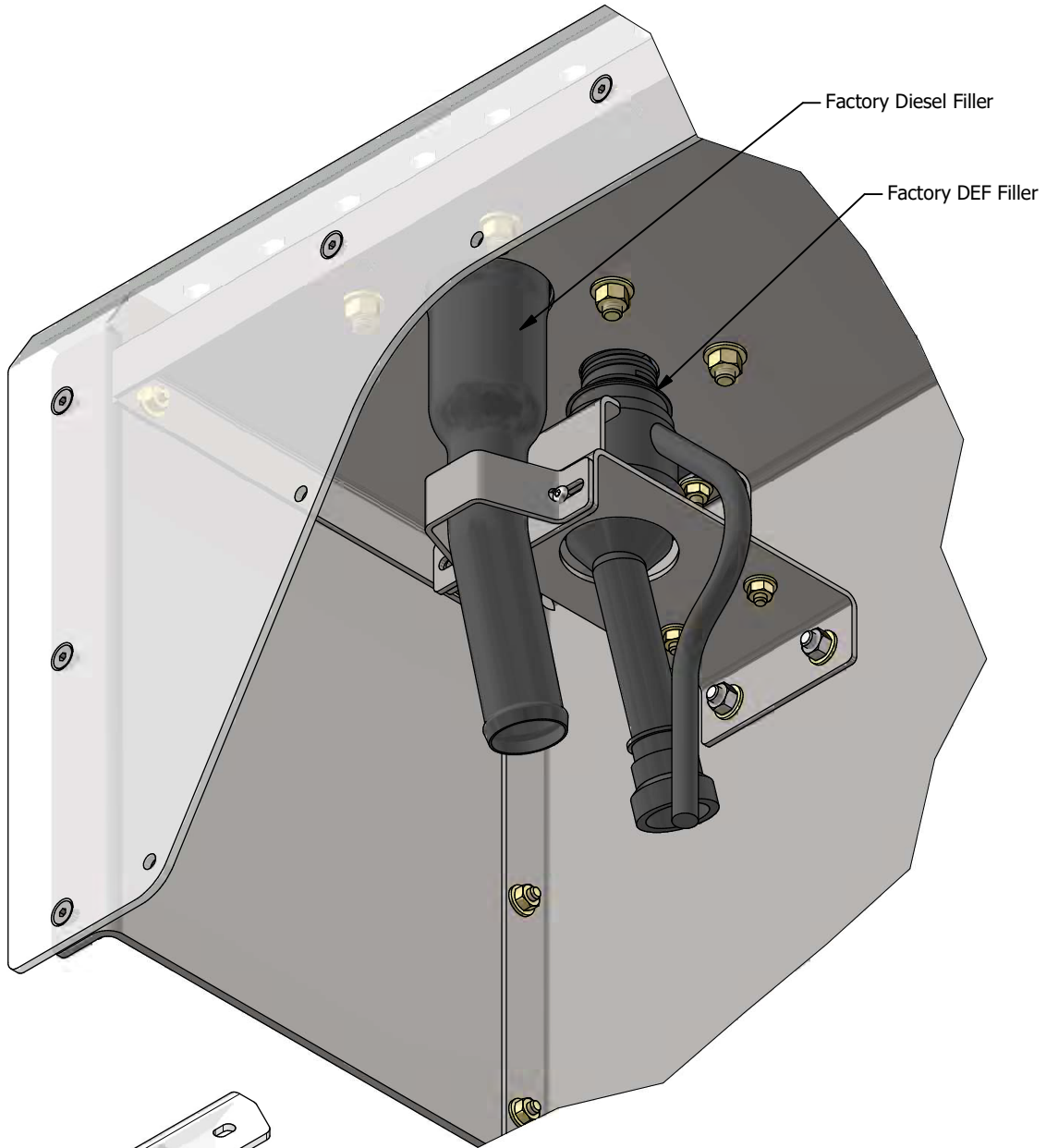

Reuse & Install
Factory Diesel Cap

Reuse & Install
Factory DEF Cap

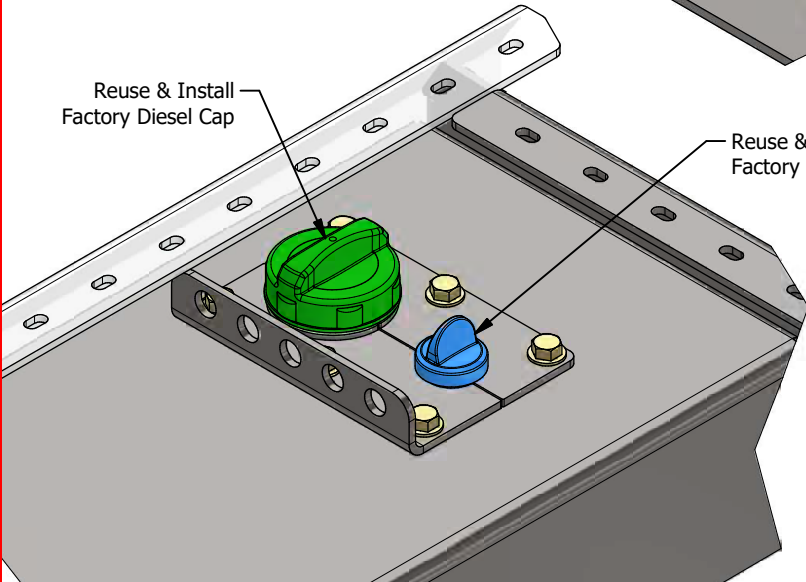

**TIGHTEN
FASTENERS**

MB1185 - Assembly Instructions JT Gladiator Long Bed

BED ASSEMBLY STEP 27

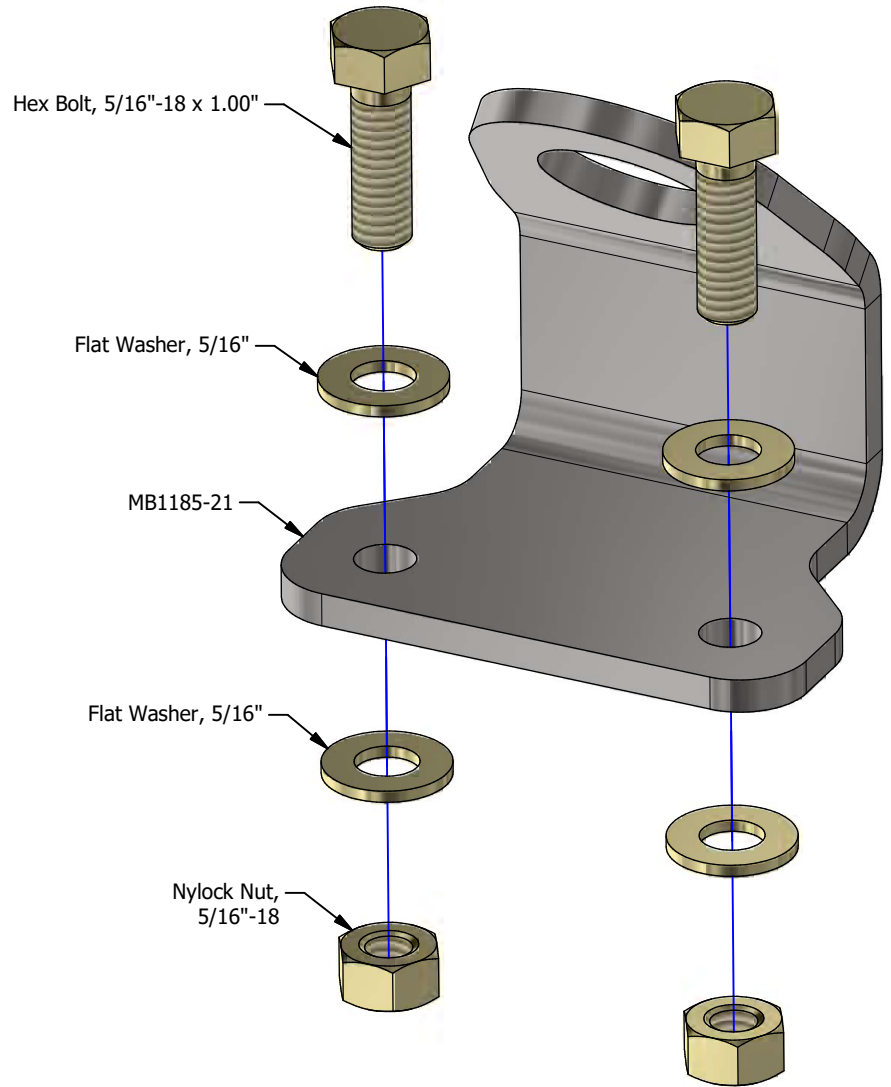
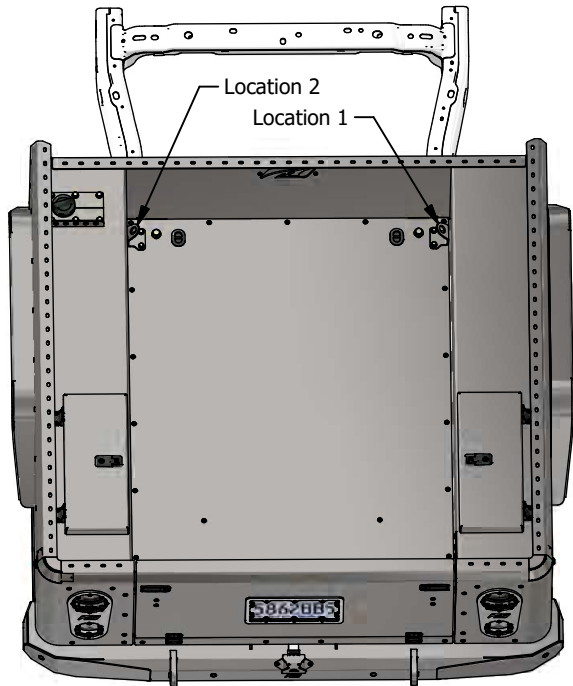

**FRONT TIE DOWN ASSEMBLY
2 LOCATIONS**

**TIGHTEN
FASTENERS**

MB1185 - Assembly Instructions JT Gladiator Long Bed

BED ASSEMBLY STEP 28

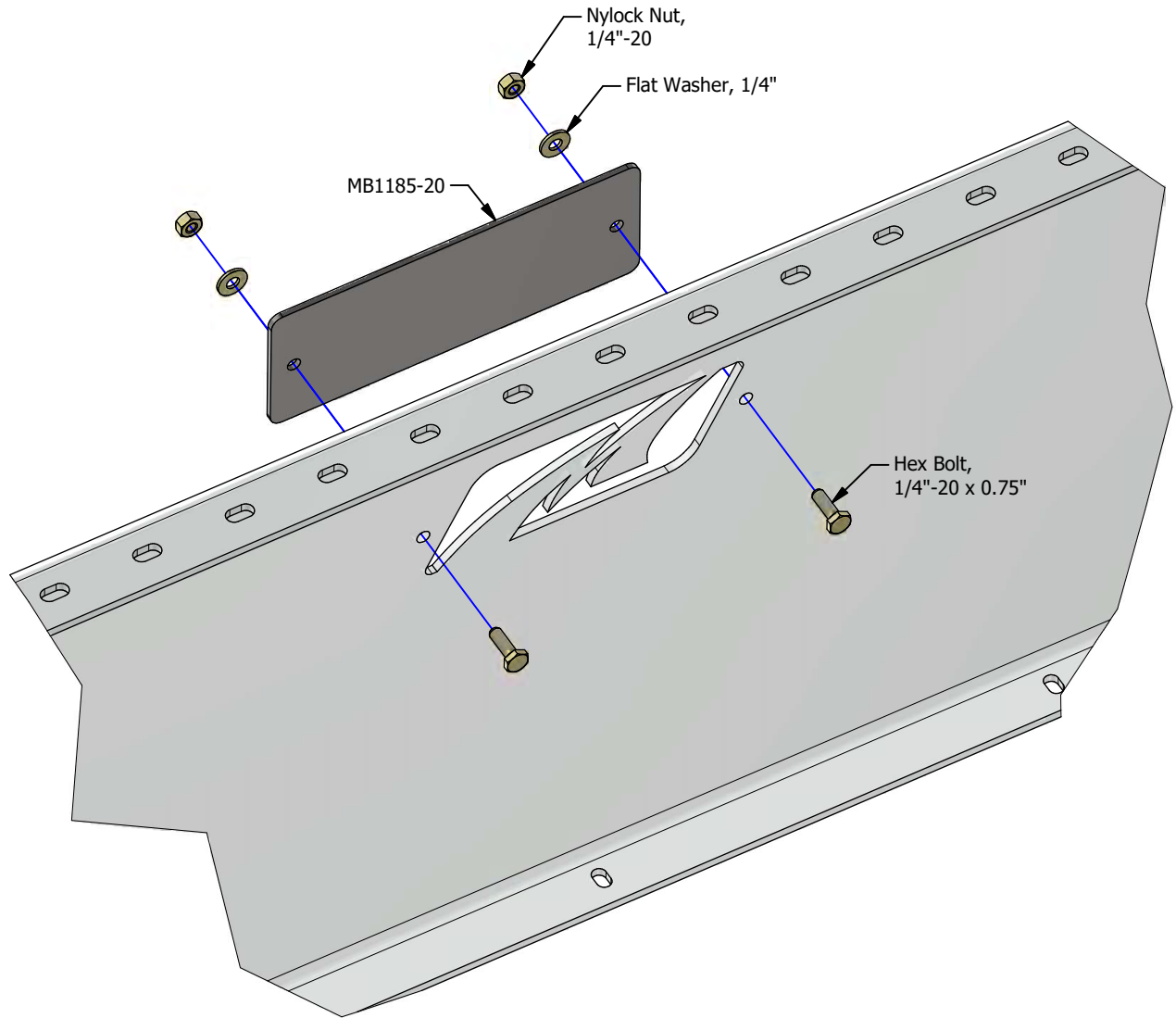

LOGO BACKING PLATE ASSEMBLY

TIGHTEN
FASTENERS

USE BAG LABELED AS
1185-KIT15

MB1185 - Assembly Instructions JT Gladiator Long Bed

BED ASSEMBLY STEP 29

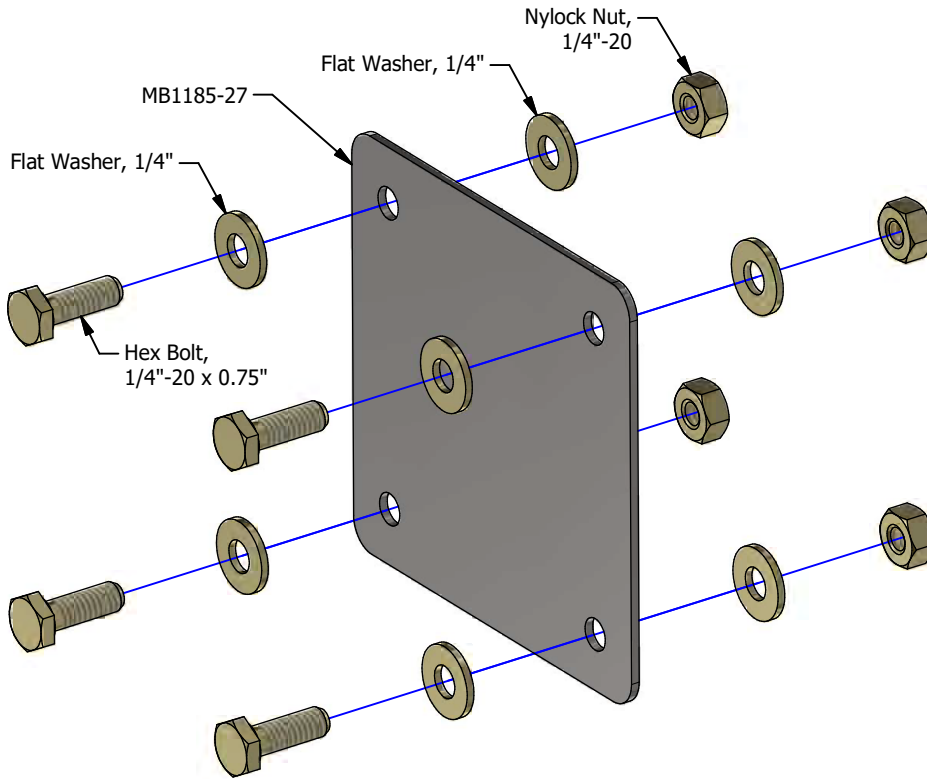

You can reuse the factory 120V receptacle from the bed of the Gladiator (if equipped). Substitute the receptacle in place of the cover plate MB1178-27 & use the supplied fasteners.

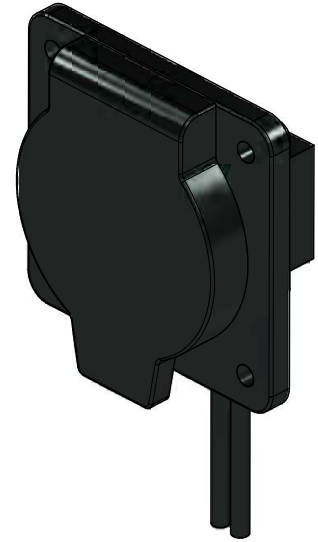

FACTORY RECEPTACLE

COVER PLATE ASSEMBLY

**TIGHTEN
FASTENERS**

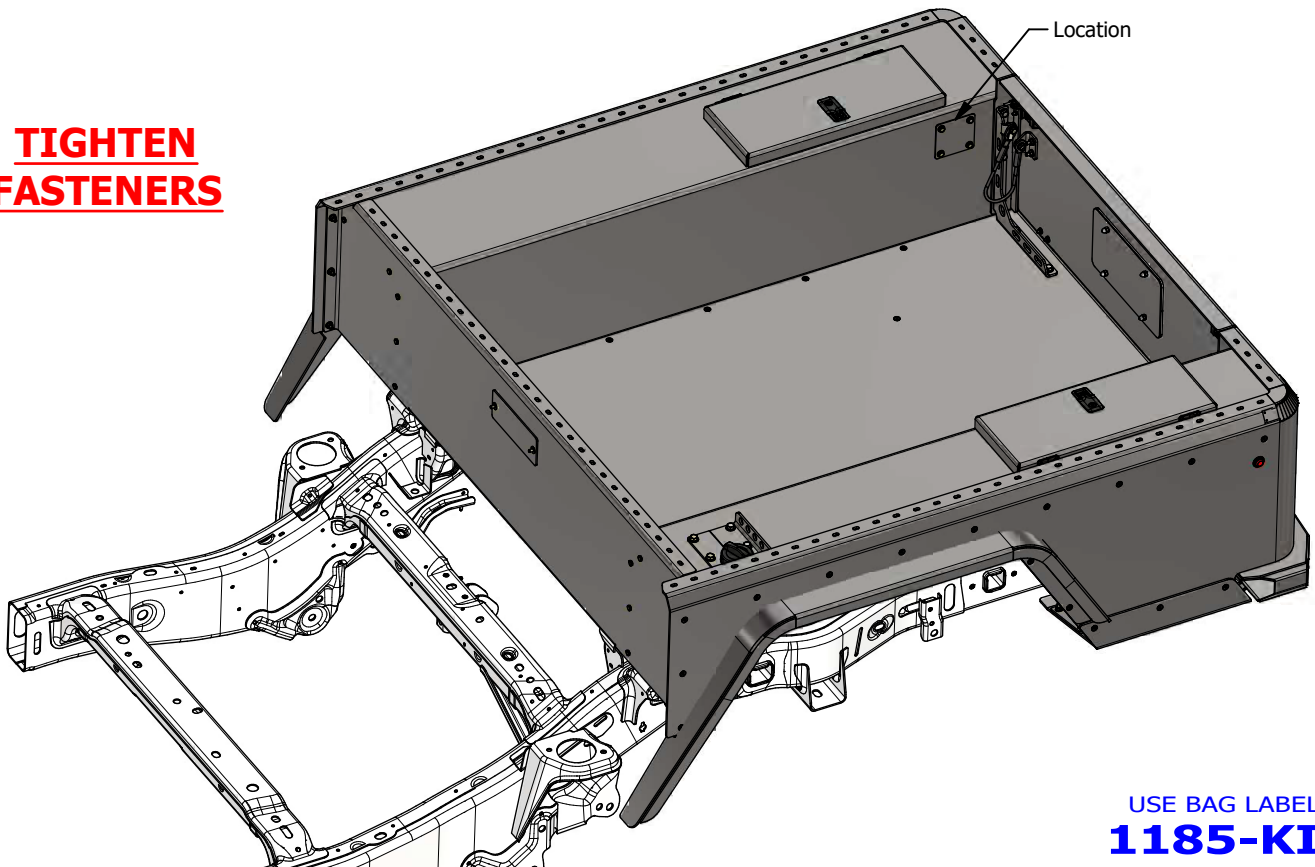

USE BAG LABELED AS
1185-KIT16

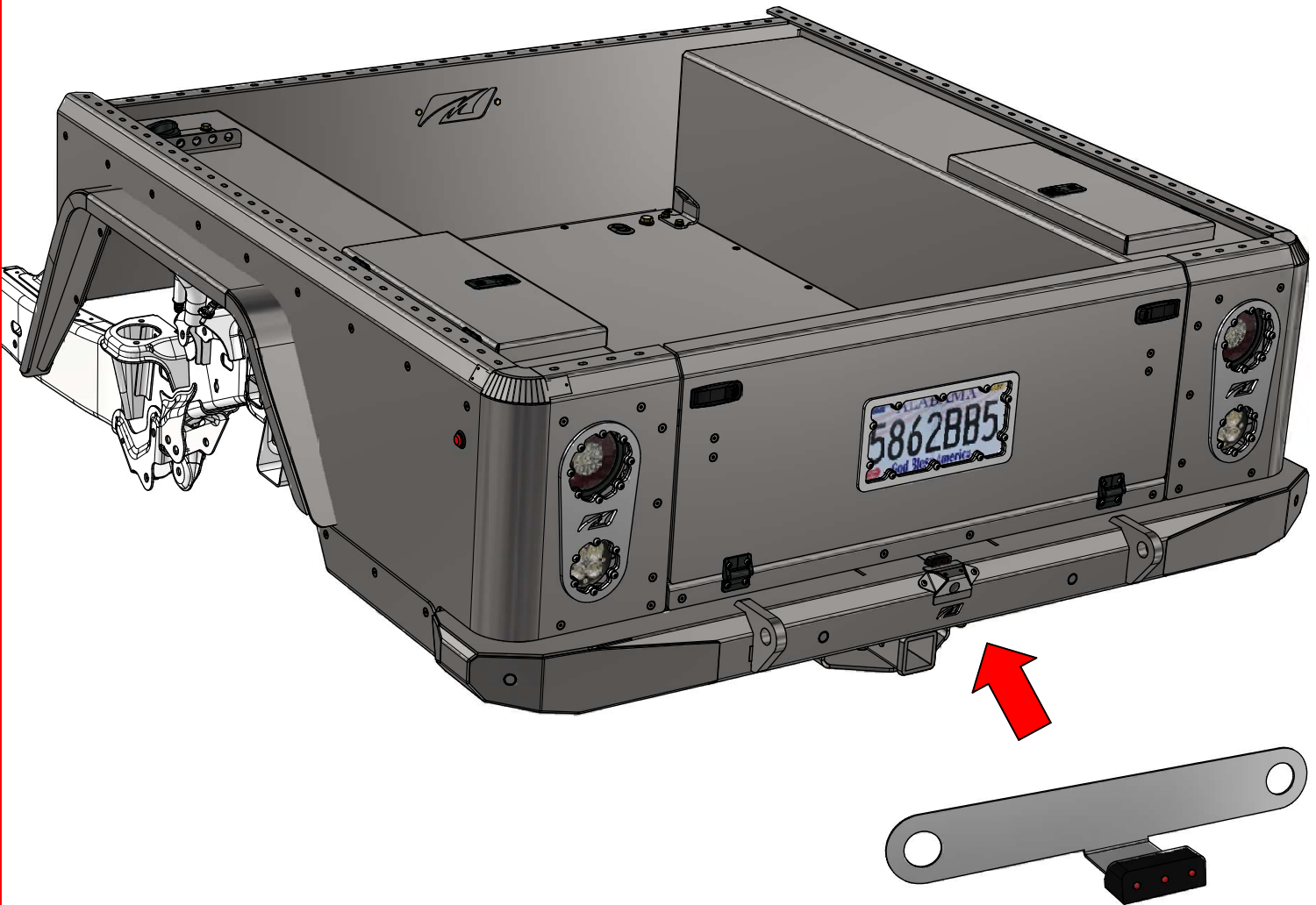
MB1185 - Assembly Instructions JT Gladiator Long Bed**BED ASSEMBLY STEP 30****Light, License Plate**

The License Plate Light installs under & behind the back lip of the floor plate. Use the existing flat washers & nuts installed earlier to mount the light.

USE BAG LABELED AS
1185-KIT17

MB1185 - Assembly Instructions JT Gladiator Long Bed**BED ASSEMBLY STEP 31**

Some jurisdictions may require Rear Side Marker Lights. If required in your area, determine your location needed, drill holes in the outer fenders & install the Side Marker Lights included with this kit.

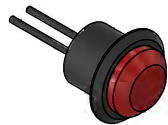
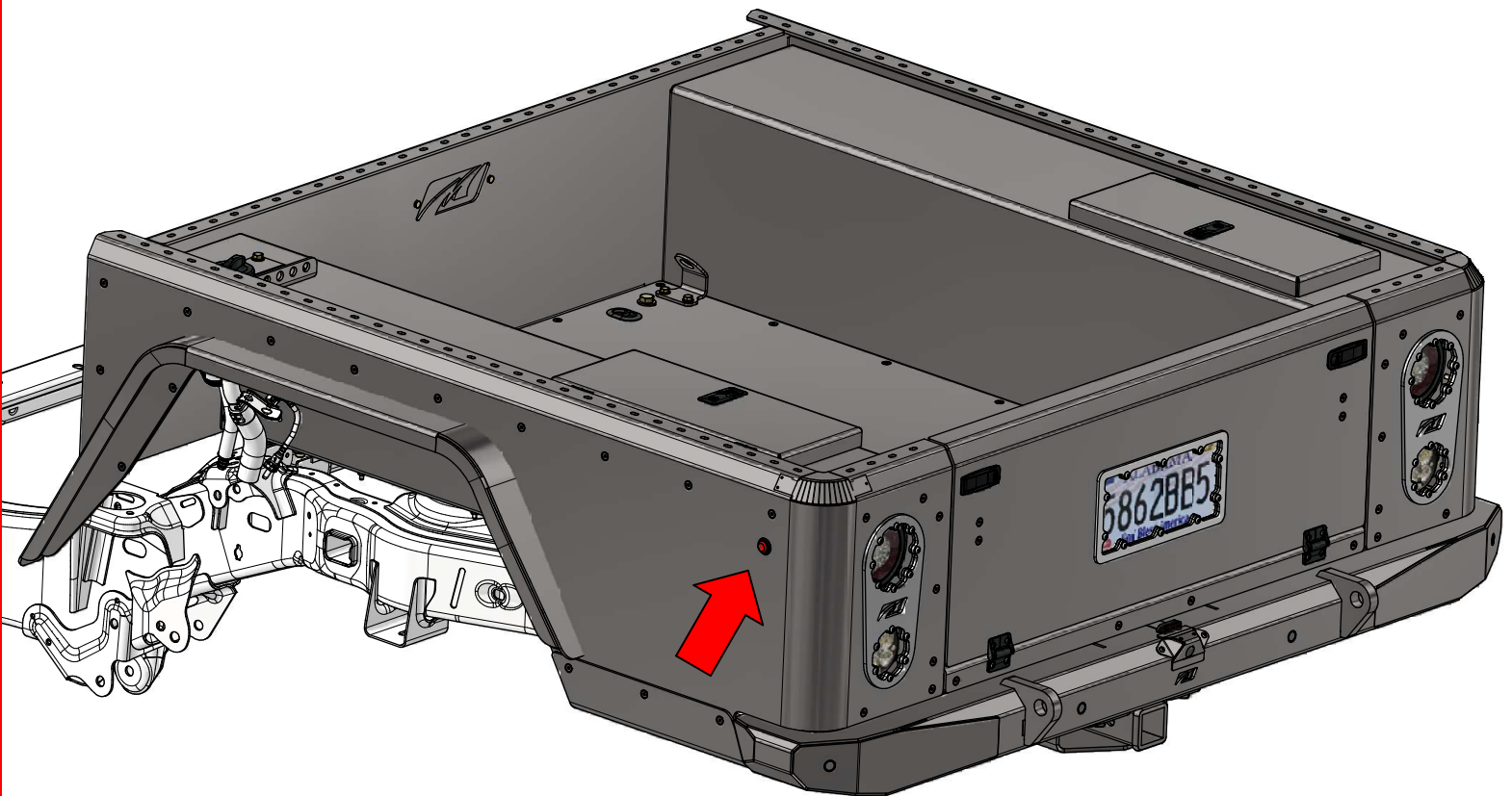

Side Marker Light
Qty 2

USE BAG LABELED AS
1185-KIT17

MB1185 - Assembly Instructions JT Gladiator Long Bed

FENDER ASSEMBLY

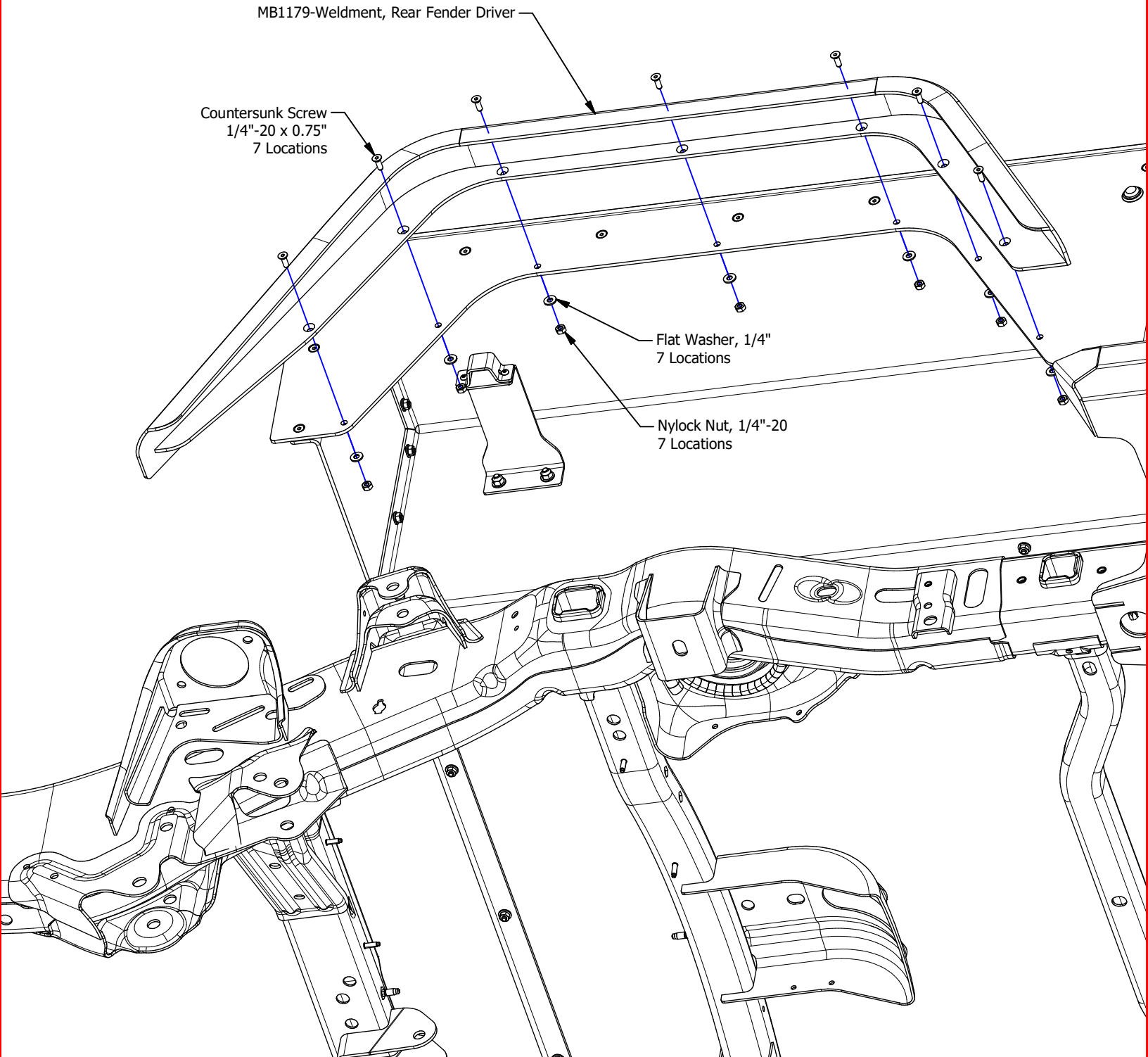

MB1185 - Assembly Instructions JT Gladiator Long Bed

WIRING FOR FACTORY NON-LED

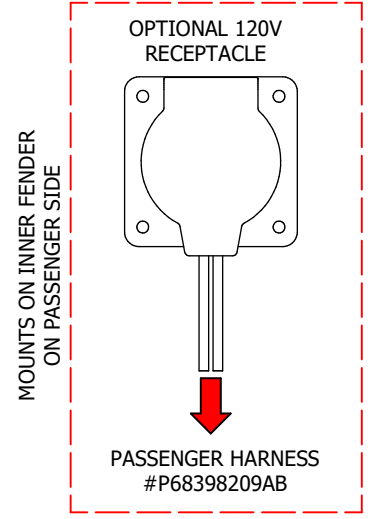
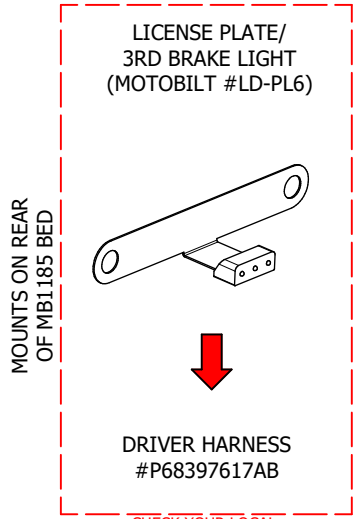
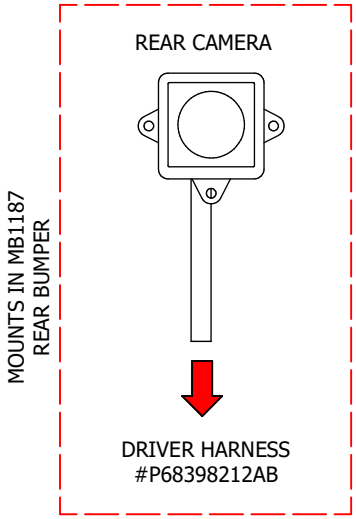
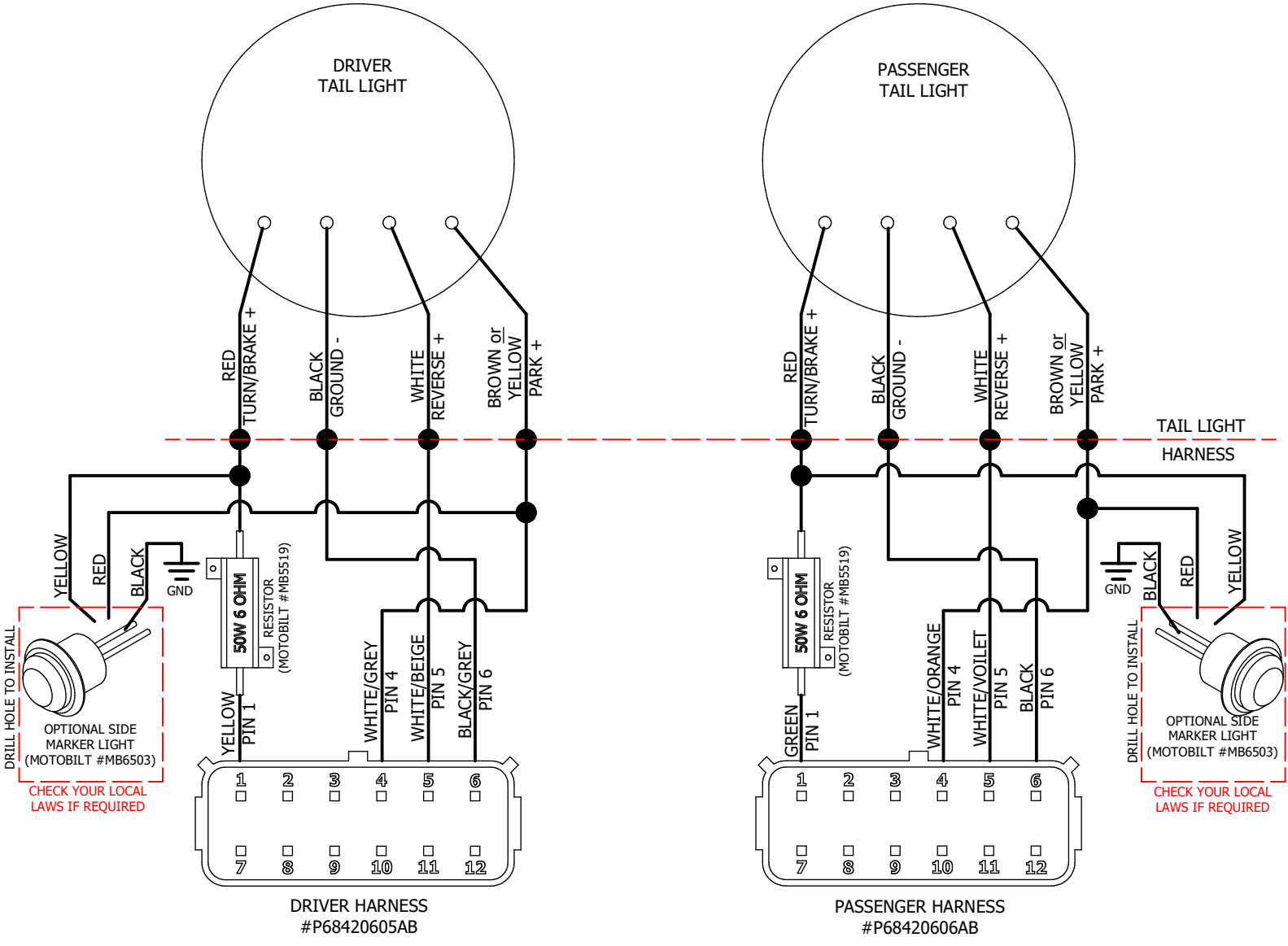

MB1185 - Assembly Instructions JT Gladiator Long Bed

WIRING FOR FACTORY LED

