

MB1178 - Assembly JT Gladiator Bobbed Bed

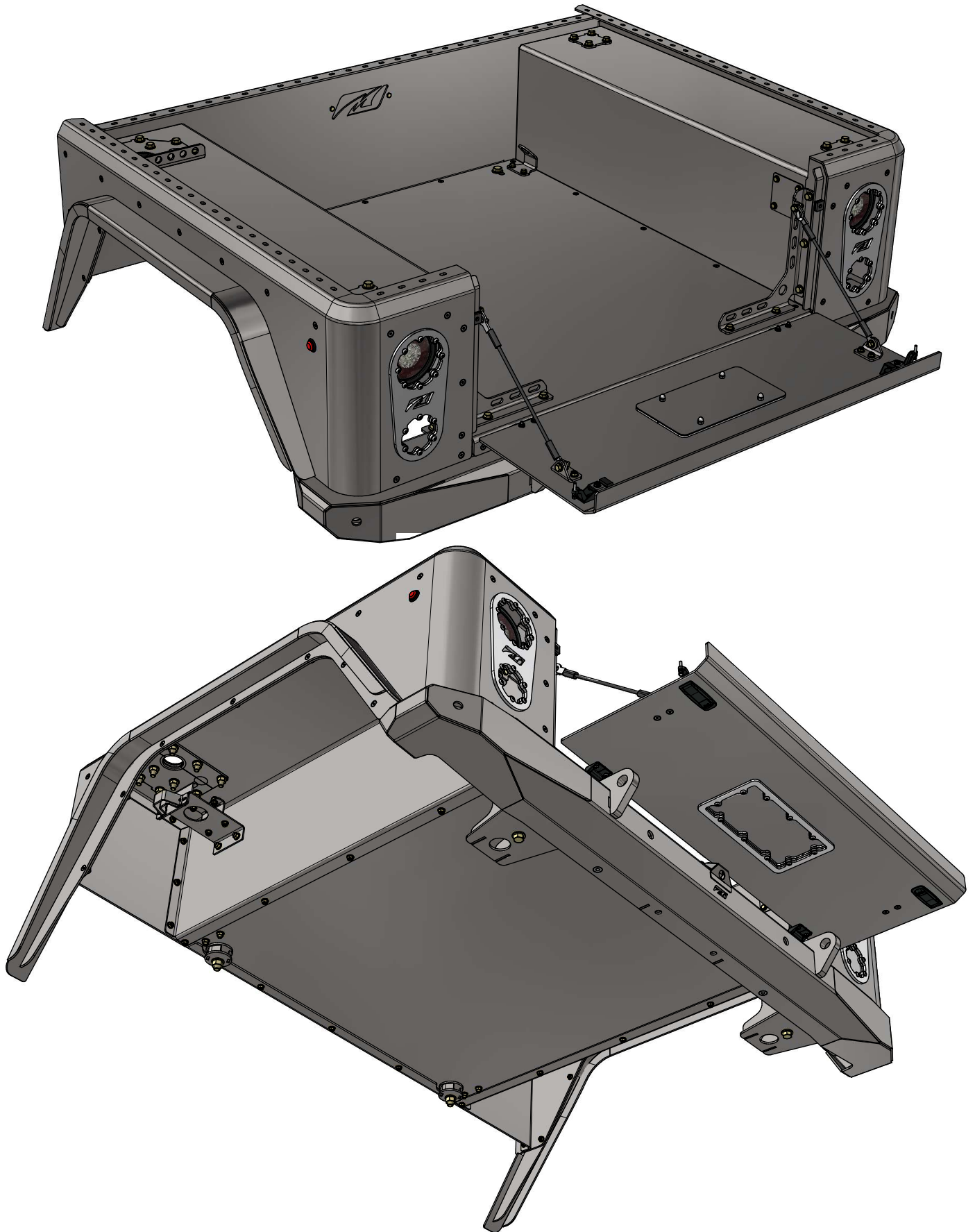

MB1178 - Assembly JT Gladiator Bobbed Bed

CONTENTS

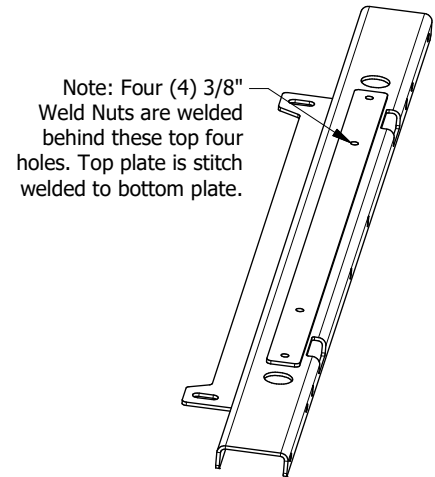
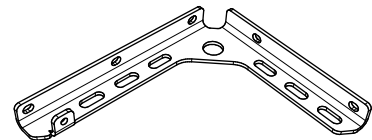
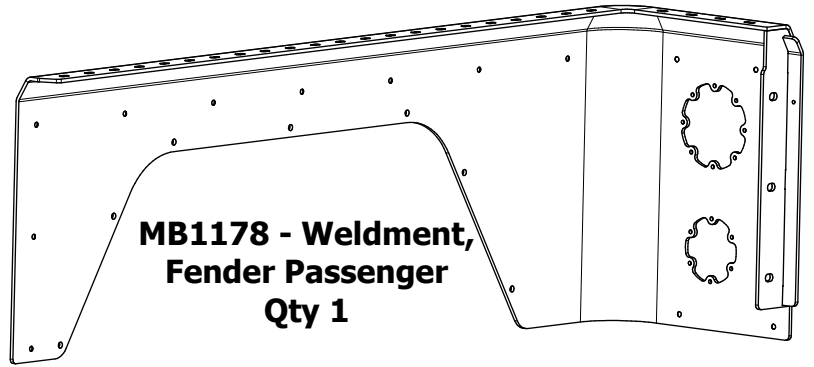
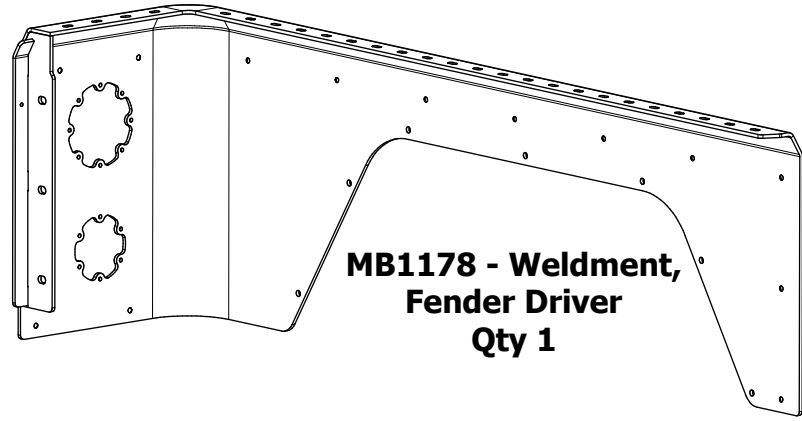
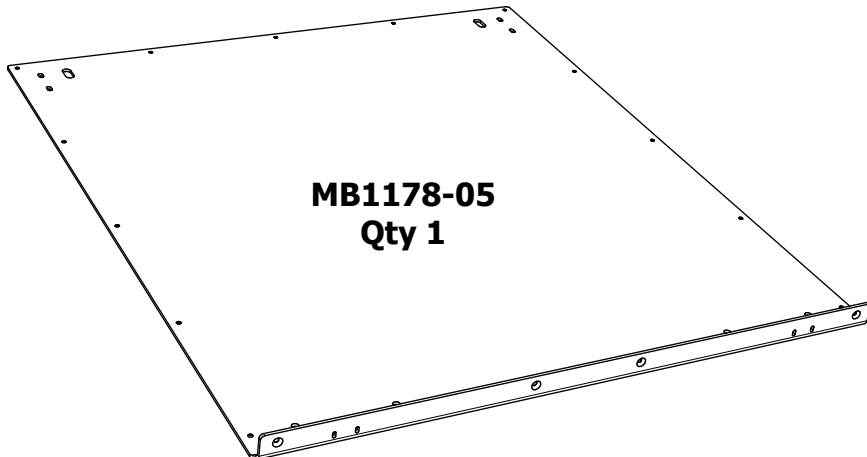
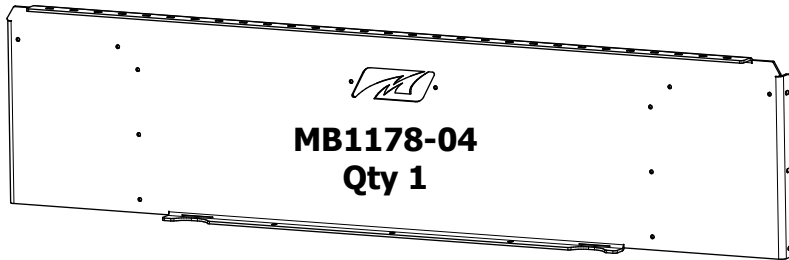
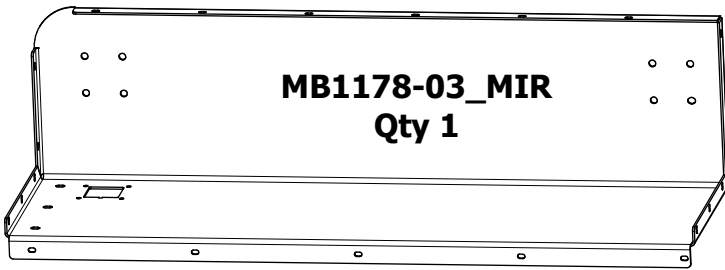
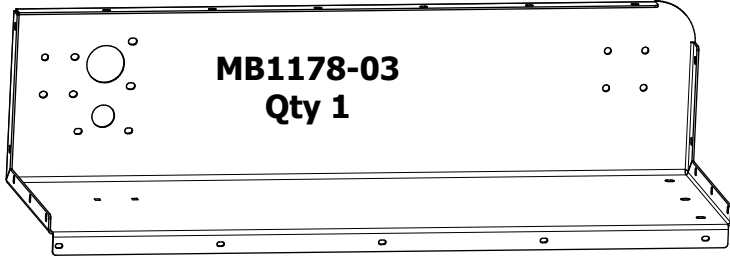
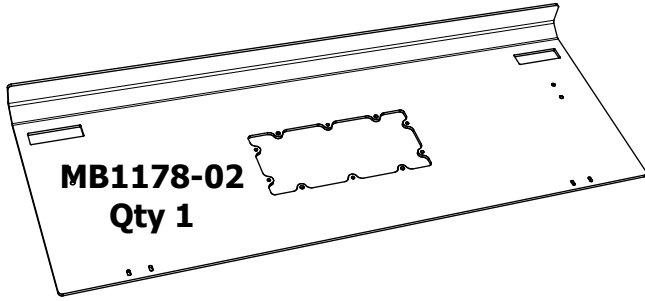

**MB1178 - Weldment,
Rear Body Mount**
Qty 1

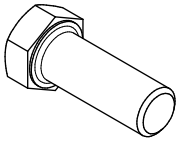
MB1178 - Assembly JT Gladiator Bobbed Bed**BAG LABELED AS
1178-KIT01**

Hex Bolt
9/16"-12 x 1.50"
Qty 2

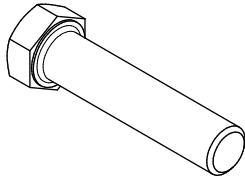

Hex Bolt
9/16"-12 x 2.50"
Qty 2

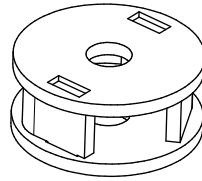

MB1178 - Weldment,
Front Body Mount
Qty 2



Flat Washer
9/16"
Qty 8

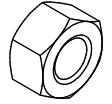

Nylock Nut
9/16"-12
Qty 4

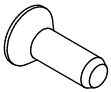
**BAG LABELED AS
1178-KIT02**

Countersunk Screw
1/4"-20 x 0.75"
Qty 40

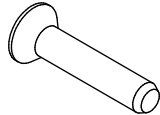

Countersunk Screw
1/4"-20 x 1.25"
Qty 8

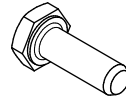

Hex Bolt
1/4"-20 x 0.75"
Qty 10



Flat Washer
1/4"
Qty 60

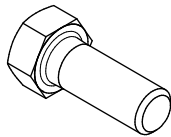

Nylock Nut
1/4"-20
Qty 60

**BAG LABELED AS
1178-KIT03**

Hex Bolt
3/8"-16 x 1.00"
Qty 10



Flat Washer
3/8"
Qty 16

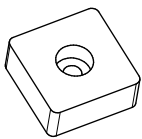

Nylock Nut
3/8"-16
Qty 6

**BAG LABELED AS
1178-KIT04**

Rubber Bumper
Qty 2

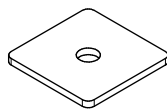

MB1178-32
Qty 6

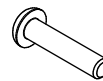

Hex Button Head Screw
#8-32 x 0.75"
Qty 2



Machine Nut
#8-32
Qty 2

MB1178 - Assembly JT Gladiator Bobbed Bed

BAG LABELED AS

1178-KIT05

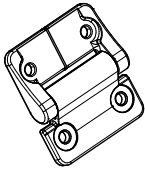

Hinge
Qty 2

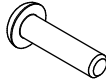

Hex Button Head Screw
#10-24 x 0.75"
Qty 8



Flat Washer
M6
Qty 8



Nylock Nut
#10-24
Qty 8

BAG LABELED AS

1178-KIT06

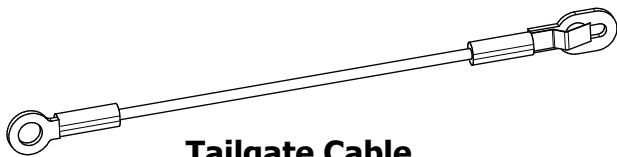

Tailgate Cable
Qty 2

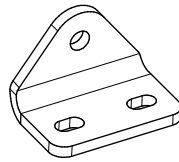

MB1178-26
Qty 2



MB1178-25
Qty 2

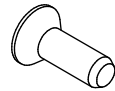

Countersunk Screw
1/4"-20 x 0.75"
Qty 4

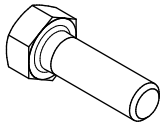

Hex Bolt
5/16"-18 x 1.00"
Qty 4



Flat Washer
5/16"
Qty 6



Nylock Nut
5/16"-18
Qty 4



Hex Nut
5/16"-18
Qty 2



Flat Washer
1/4"
Qty 4



Nylock Nut
1/4"-20
Qty 4

BAG LABELED AS

1178-KIT07

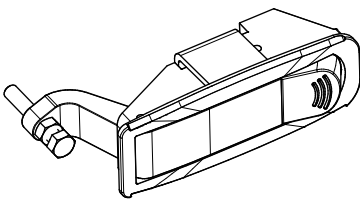

Latch
Qty 2

BAG LABELED AS

1178-KIT08

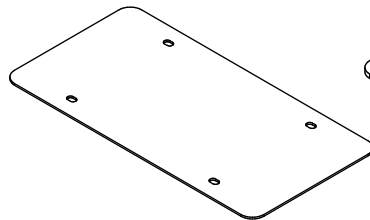

MB1178-29
Qty 1

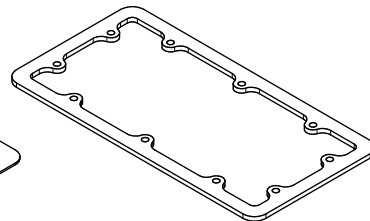

MB1178-24
Qty 1

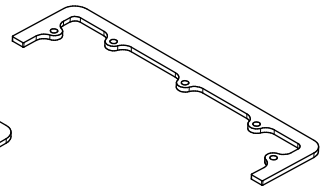

MB1178-31
Qty 2

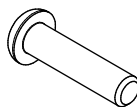

Hex Button Head Screw
1/4"-20 x 1.00"
Qty 4



Hex Button Head Screw
1/4"-20 x 0.50"
Qty 6



Cap Nut
1/4"-20
Qty 4

MB1178 - Assembly JT Gladiator Bobbed Bed

BAG LABELED AS
1178-KIT09

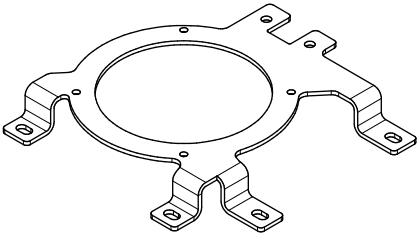

MB1178-22
Qty 1

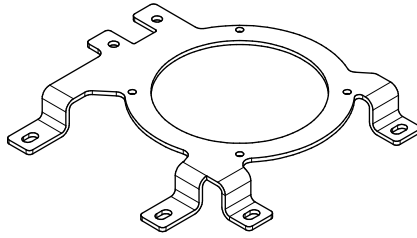

MB1178-22_MIR
Qty 1

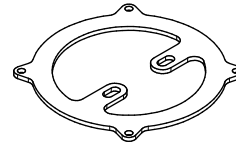

MB1178-30
Qty 2



MB1178-28
Qty 2

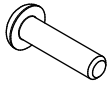

Hex Button Head Screw
#10-24 x 0.75"
Qty 8



Nylock Nut
#10-24
Qty 8

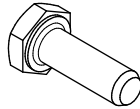

Hex Bolt
1/4"-20 x 3/4"
Qty 4



Flat Washer
1/4"
Qty 4



Nylock Nut
1/4"-20
Qty 4

BAG LABELED AS
1178-KIT10

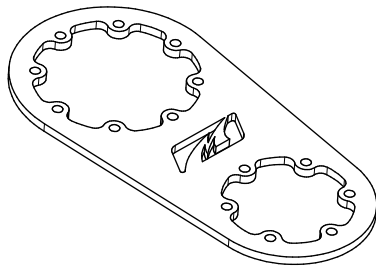

MB1178-23
Qty 2



Hex Button Head Screw
1/4"-20 x 0.50"
Qty 28

BAG LABELED AS
1178-KIT11

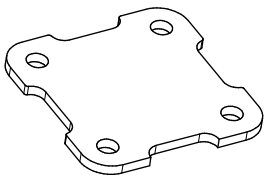

MB1178-33
Qty 6

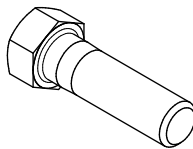

Hex Bolt
3/8"-16 x 1.50"
Qty 12



Flat Washer
3/8"
Qty 24

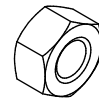

Nylock Nut
3/8"-16
Qty 12

MB1178 - Assembly JT Gladiator Bobbed Bed

GASOLINE COMPATIBLE PARTS
SHOWN IN RED

BAG LABELED AS

1178-KIT12

DIESEL COMPATIBLE PARTS
SHOWN IN GREEN

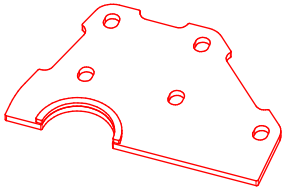

**MB1178 - Weldment,
Filler Clamp 01 - Gas**
Qty 1

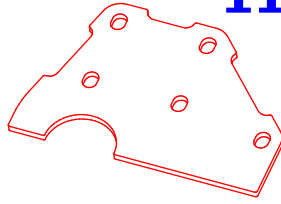

**MB1178-36
Underside Plate 01 - Gas**
Qty 1

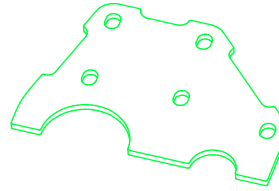

**MB1178-13
Underside Plate 03 - Diesel**
Qty 1

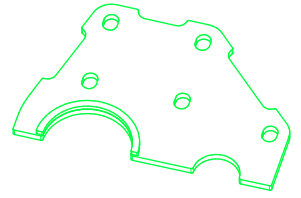

**MB1178 - Weldment,
Filler Clamp 03 - Diesel**
Qty 1

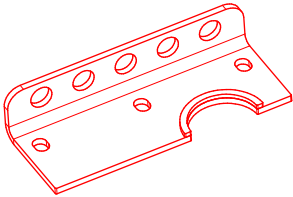

**MB1178 - Weldment,
Filler Clamp 02 - Gas**
Qty 1

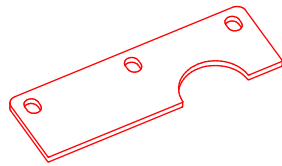

**MB1178-35
Underside Plate 02 - Gas**
Qty 1

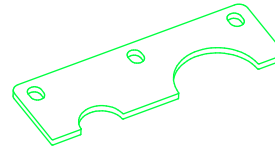

**MB1178-34
Underside Plate 04 - Diesel**
Qty 1

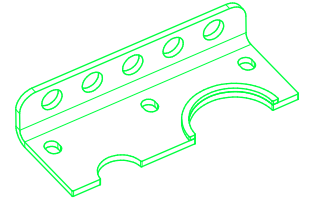

**MB1178 - Weldment,
Filler Clamp 04 - Diesel**
Qty 1

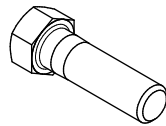

**Hex Bolt
3/8"-16 x 1.50"**
Qty 8



**Flat Washer
3/8"**
Qty 16



**Nylock Nut
3/8"-14**
Qty 8

GASOLINE COMPATIBLE PARTS
SHOWN IN RED

BAG LABELED AS

1178-KIT13

DIESEL COMPATIBLE PARTS
SHOWN IN GREEN

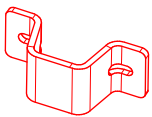

**MB1178-15
Nozzle Clamp 01 - Gas**
Qty 1

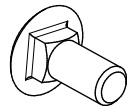

**Carriage Bolt
5/16" x 0.75"**
Qty 2

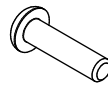

**Hex Button Head Screw
#10-24 x 0.75"**
Qty 2

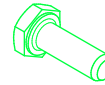

**Hex Bolt
1/4"-20 x 0.75"**
Qty 5

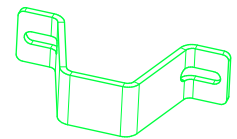

**MB1178-40
Nozzle Clamp 02 - Diesel**
Qty 1

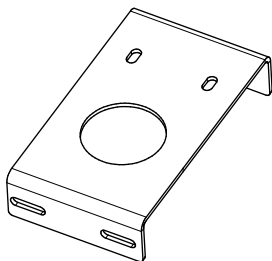

**MB1178-16
Mounting Plate Clamp
(common to both Gas & Diesel)**
Qty 1



**Flat Washer
5/16"**
Qty 2



**Flat Washer
M6**
Qty 2



**Flat Washer
1/4"**
Qty 10

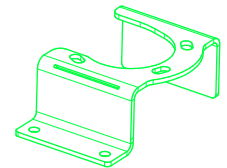

**MB1178-39
Nozzle Clamp 03 - Diesel**
Qty 1



**Nylock Nut
5/16"-18**
Qty 2



**Nylock Nut
#10-24**
Qty 2



**Nylock Nut
1/4"-20**
Qty 5

MB1178 - Assembly JT Gladiator Bobbed Bed

BAG LABELED AS

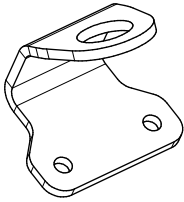
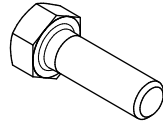
1178-KIT14**MB1178-21**
Qty 2**Hex Bolt**
5/16"-18 x 1.00"
Qty 4**Flat Washer**
5/16"
Qty 8**Nylock Nut**
5/16"-18
Qty 4

BAG LABELED AS

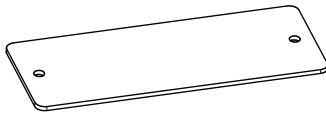
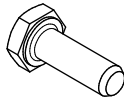
1178-KIT15**MB1178-20**
Qty 1**Hex Bolt**
1/4"-20 x 0.75"
Qty 2**Flat Washer**
1/4"
Qty 2**Nylock Nut**
1/4"-20
Qty 2

BAG LABELED AS

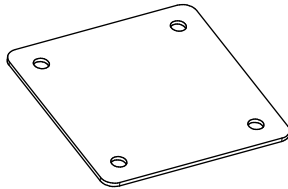
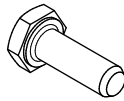
1178-KIT16**MB1178-27**
Qty 1**Hex Bolt**
1/4"-20 x 0.75"
Qty 4**Flat Washer**
1/4"
Qty 8**Nylock Nut**
1/4"-20
Qty 4

BAG LABELED AS

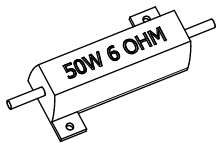
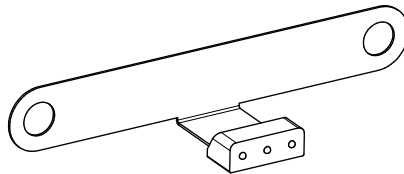
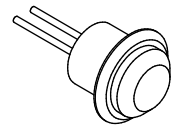
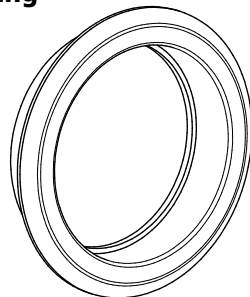
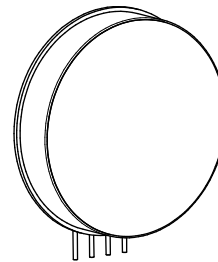
1178-KIT17**MB5519**
Resistor for Non-LED Wiring
Qty 2**Light, License Plate**
Qty 1**Side Marker Light**
Qty 2**MB6502**
Grommet
Qty 2**MB6502**
LED Tail Light
Qty 2

MB1178 - Assembly JT Gladiator Bobbed Bed

BAG LABELED AS
1178-SPARES

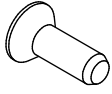

Countersunk Screw
1/4"-20 x 0.75"
Qty 6

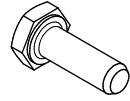

Hex Bolt
1/4"-20 x 0.75"
Qty 6



Flat Washer
1/4"
Qty 6



Nylock Nut
1/4"-20
Qty 6

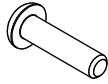

Hex Button Head Screw
#10-24 x 0.75"
Qty 6



Nylock Nut
#10-24
Qty 6



Hex Button Head Screw
1/4"-20 x 0.50"
Qty 6

MB1179 - Assembly Rear Fenders

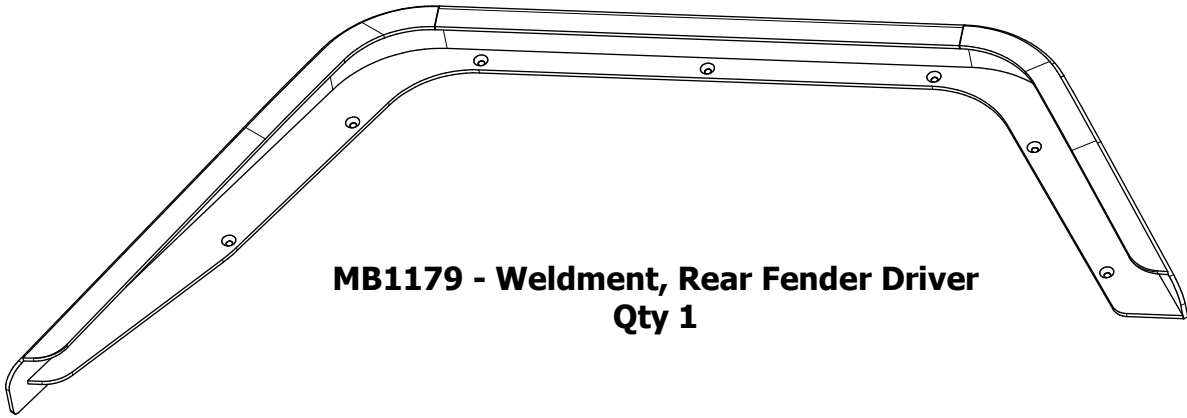

**MB1179 - Weldment, Rear Fender Driver
Qty 1**

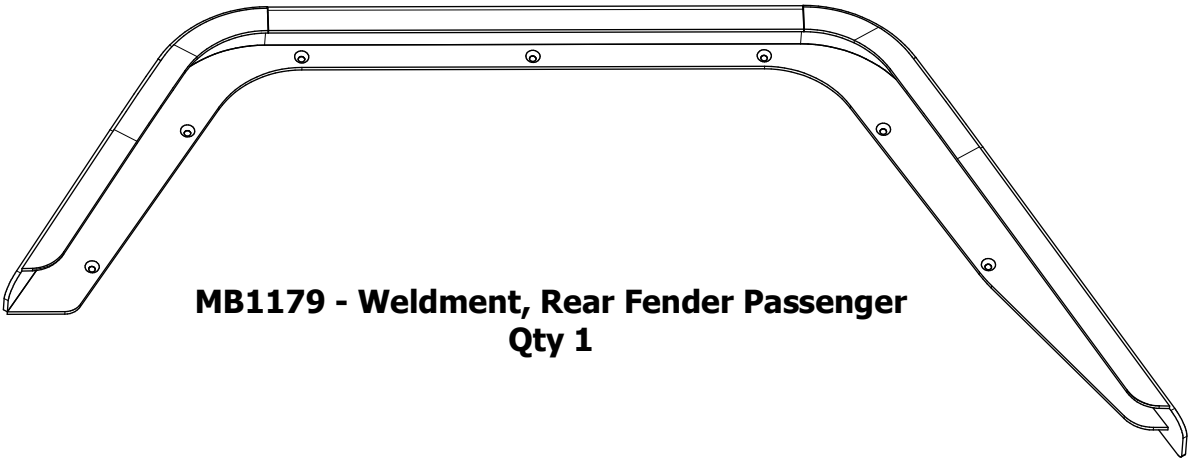

**MB1179 - Weldment, Rear Fender Passenger
Qty 1**

BAG LABELED AS

1179

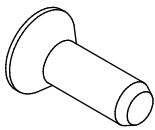

**Countersunk Screw
1/4"-20 x 0.75" Long
Qty 14**



**Flat Washer
1/4"
Qty 14**

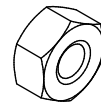

**Nylock Nut
1/4"-20
Qty 14**

MB1180 - Assembly Rear Bumper

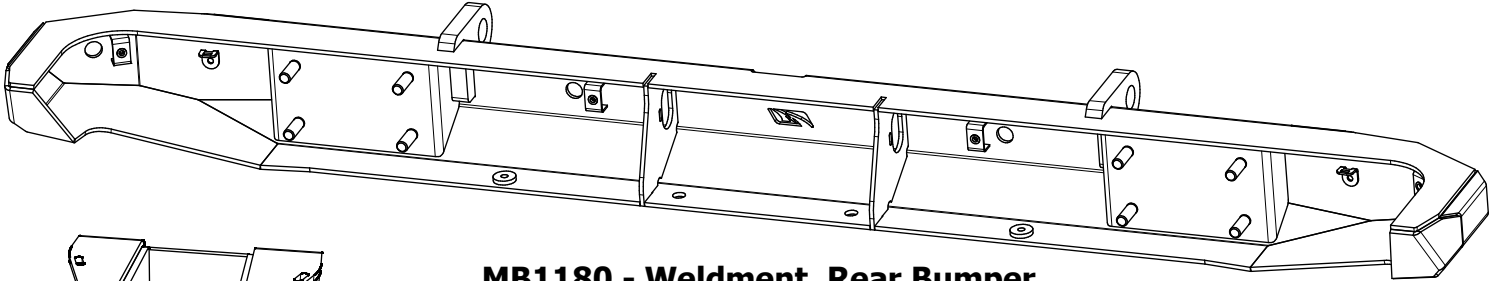

MB1180 - Weldment, Rear Bumper
Qty 1

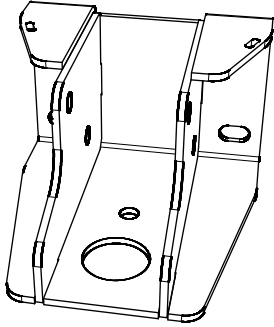

MB1180 - Weldment, Frame Mount
Qty 2

BAG LABELED AS
1180

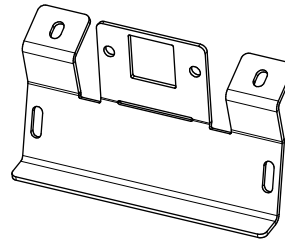

MB1180-14
Qty 1

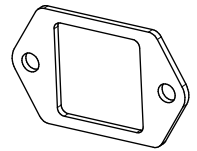

MB1180-15
Qty 1

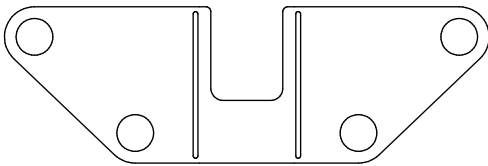

MB1180-12
Qty 2

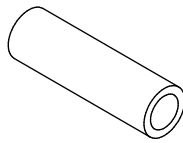

MB1180-Tube 01
Qty 4

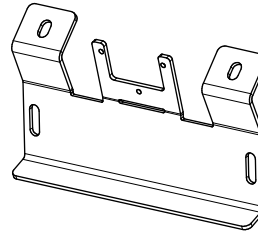

MB1180-11
Qty 1

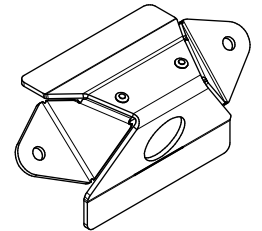

MB1180-Camera Housing
Qty 1

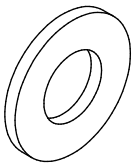

Flat Washer
1/2"
Qty 20



Flat Washer
M6
Qty 4

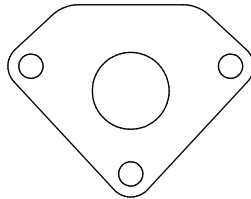

MB2115-08
Qty 1



Nylock Nut
#10-24
Qty 4



Screw
M3-0.5 x 8mm
Qty 3

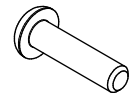

Hex Button Head Screw
#10-24 x 0.75"
Qty 8

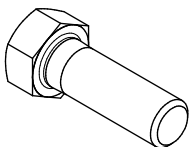

Hex Bolt
1/2"-13 x 1.50"
Qty 2

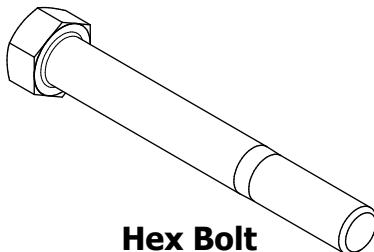

Hex Bolt
1/2"-13 x 4.00"
Qty 4

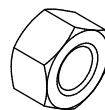

Nylock Nut
1/2"-13
Qty 14

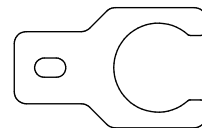

MB2117-01
Qty 4

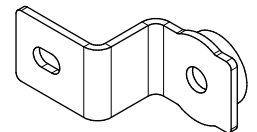

MB2145
Park Sensor Blank Off
Qty 4

MB1178 - Assembly JT Gladiator Bobbed Bed

PREPARATION

Cleaning/Paint/Finishing

All Motobilt parts are shipped as raw (unfinished) steel. A light coating of anti-corrosion oil may be present on all manufactured parts to prevent corrosion during shipping. Apply acetone to all steel parts & thoroughly clean before applying paint.

We recommend to paint or powder coat all steel parts prior to installation.

Factory Gladiator Bed Removal

1. Disconnect negative battery terminal.
2. Disconnect all wiring connecting rear bumper & bed to the frame. Unplug tail light connections at the frame, driver side rear above the tire & passenger side rear above the tire.
3. Remove factory rear bumper. If equipped, remove all sensors & wiring harness from inside the rear bumper.
4. Using a 15mm socket & socket extension, remove six (6) factory bolts that secure the factory bed to the frame. There are four (4) bolts behind the axle inside the frame tube. There are two (2) bolts in front of the axle inboard of the frame tube.
5. Unhook the fuel filler hose, breather hose & electrical connections from beneath the fuel fill cap location.
6. Due the weight of the factory Gladiator bed, you may need four (4) or more people to manually lift the bed off the frame. If using a forklift or crane, use approved slings & safe lifting practices to ensure everyone's safety during bed removal. You may need to lift the bed at an angle, rather than lifting straight up vertically, to avoid contact with the cab.
7. With the factory bed safely removed from the frame, remove all remaining wiring harnesses from the bed.

8. If equipped, remove the 120 volt receptacle from the factory bed.

9. If equipped, remove the factory rear camera from the tail gate.

10. Protect the cab, all painted areas & all glass using a fireproof (or welders) blanket or similar.

11. Seal & protect all open fuel hoses or connections from open flame or sparks.

Sensor Compatibility (if equipped)

The MB1178 Gladiator Bobbed Bed Kit is designed to **NOT** work with the blind spot sensors located in the tail lights. If your Gladiator is equipped with blind spot sensors in the tail light housing, they can be programmed to be turned off by using an aftermarket programmer.

The optional MB1180 Gladiator Rear Bumper **IS** designed to reuse the park assist sensors in the factory rear bumper.

MB1178 - Assembly JT Gladiator Bobbed Bed

CUTTING THE FRAME

This installation requires a permanent modification to the rear frame, wiring, tail lights, sensors, rear camera, weight distribution & handling of the vehicle. Consult your local laws & insurance company before making these modifications.

The function of this kit is to permanently shorten the bed length & cut off the rear frame to increase the rear departure angle of the vehicle.

You will not be able to return your vehicle back to stock after this modification.

Included with your kit is our MB1180 Gladiator Rear Bumper that was specifically designed to work with the new Gladiator Bed.

The dimensions & procedure shown here for the cutting & removal of the rear portion of the frame are very specific to our MB1180 Gladiator Rear Bumper. The frame will be cut so the frame sits approximately 1/4"-1/2" inset of the new MB1178 Bed Body.

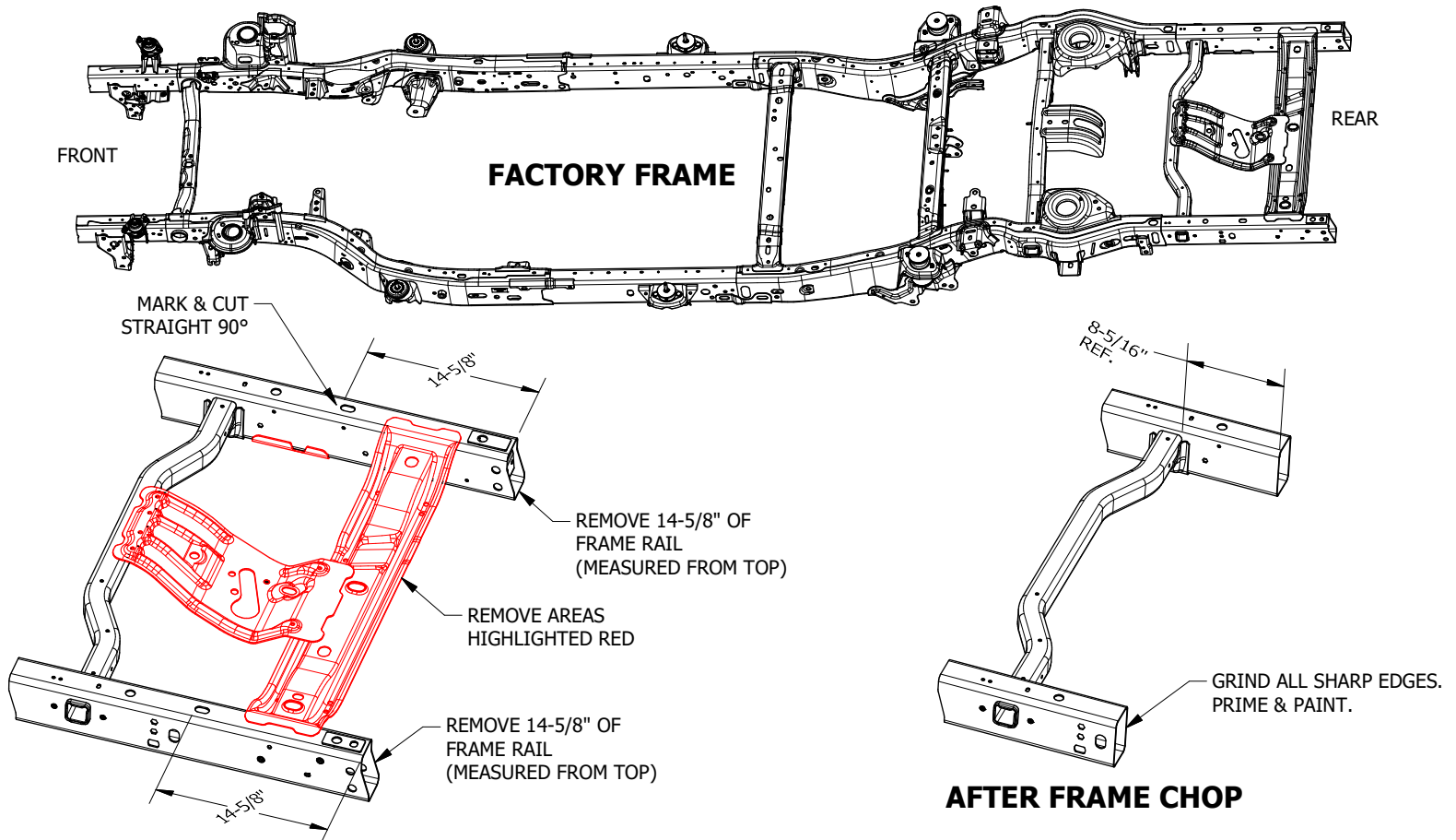

MB1178 - Assembly JT Gladiator Bobbed Bed

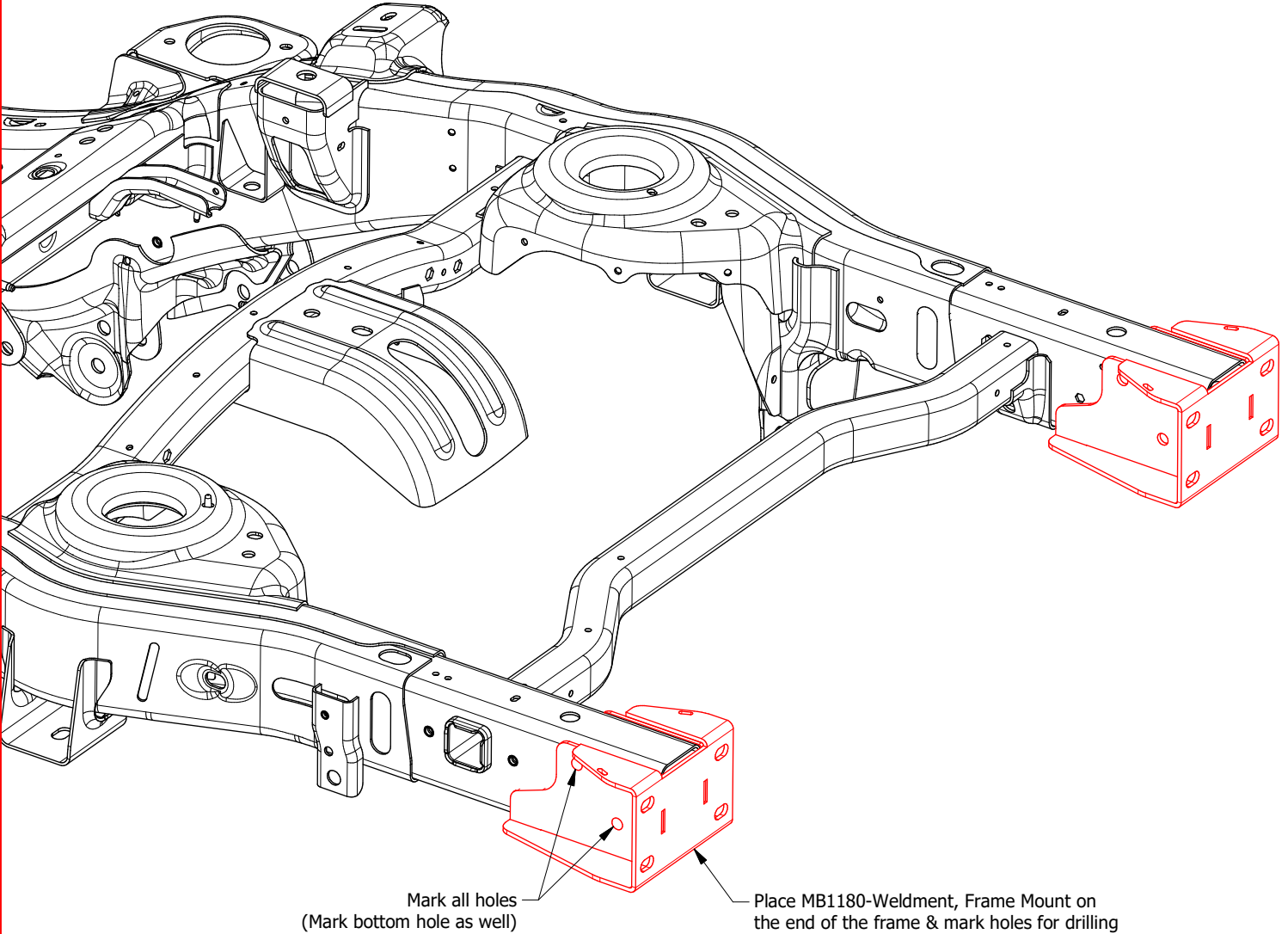
BUMPER ASSEMBLY STEP 1

After marking all holes, remove MB1180-Weldment Frame Mounts. Drill all holes to 1/2" diameter. Check fitment after drilling & ream as necessary. Remove brackets after fitting.

MB1178 - Assembly JT Gladiator Bobbed Bed

BUMPER ASSEMBLY STEP 2

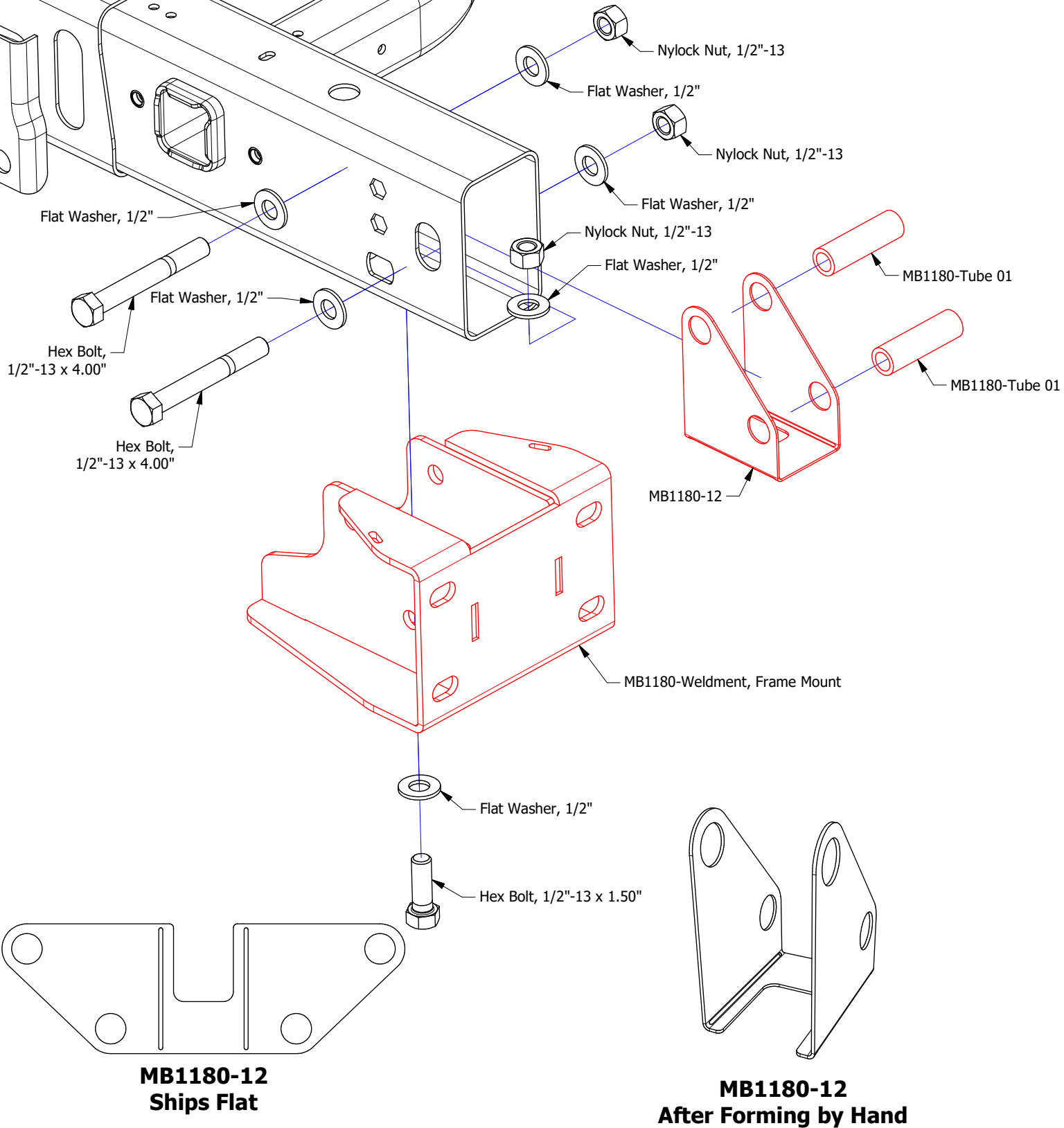

USE BAG LABELED AS
1180

MB1178 - Assembly JT Gladiator Bobbed Bed
BUMPER ASSEMBLY STEP 3

Place your factory rear bumper face down with the wiring facing up.

Label the positions of all wiring connections & park sensors. Example: Park Sensor - Outer Driver, Park Sensor - Middle Driver, Park Sensor - Outer Passenger, Park Sensor - Middle Passenger, Connector - Driver, Connector - Passenger, License Plate Light - Driver, License Plate Light - Passenger.

The wiring connectors that connect the bumper wiring harness to the vehicle's main wiring harness on the driver side are a different shape than the wiring connectors on the passenger side. Labeling them now will ensure you position the bumper wiring harness correctly into your new Motobilt bumper. Also, the positions of the park sensors must be placed back into their relative positions in the new bumper.

Disconnect the four (4) park sensors from the factory rear bumper by opening the plastic bezels slightly with a screwdriver to remove them. The factory plastic bezels will not be reused.

Remove the complete factory wiring & sensors from the factory bumper.



Park Sensor

MB1178 - Assembly JT Gladiator Bobbed Bed**BUMPER ASSEMBLY STEP 4**

Install the factory rear bumper wiring harness & factory rear park sensors in the new MB1180 Motobilt Rear Bumper. Place sensors back into their relative positions using your labeling from the previous step.

The sensor fits into the hole in the bumper. Use the provided sensor clamps (MB2117-01) to secure the park sensor. Repeat for the other three (3) park sensors.

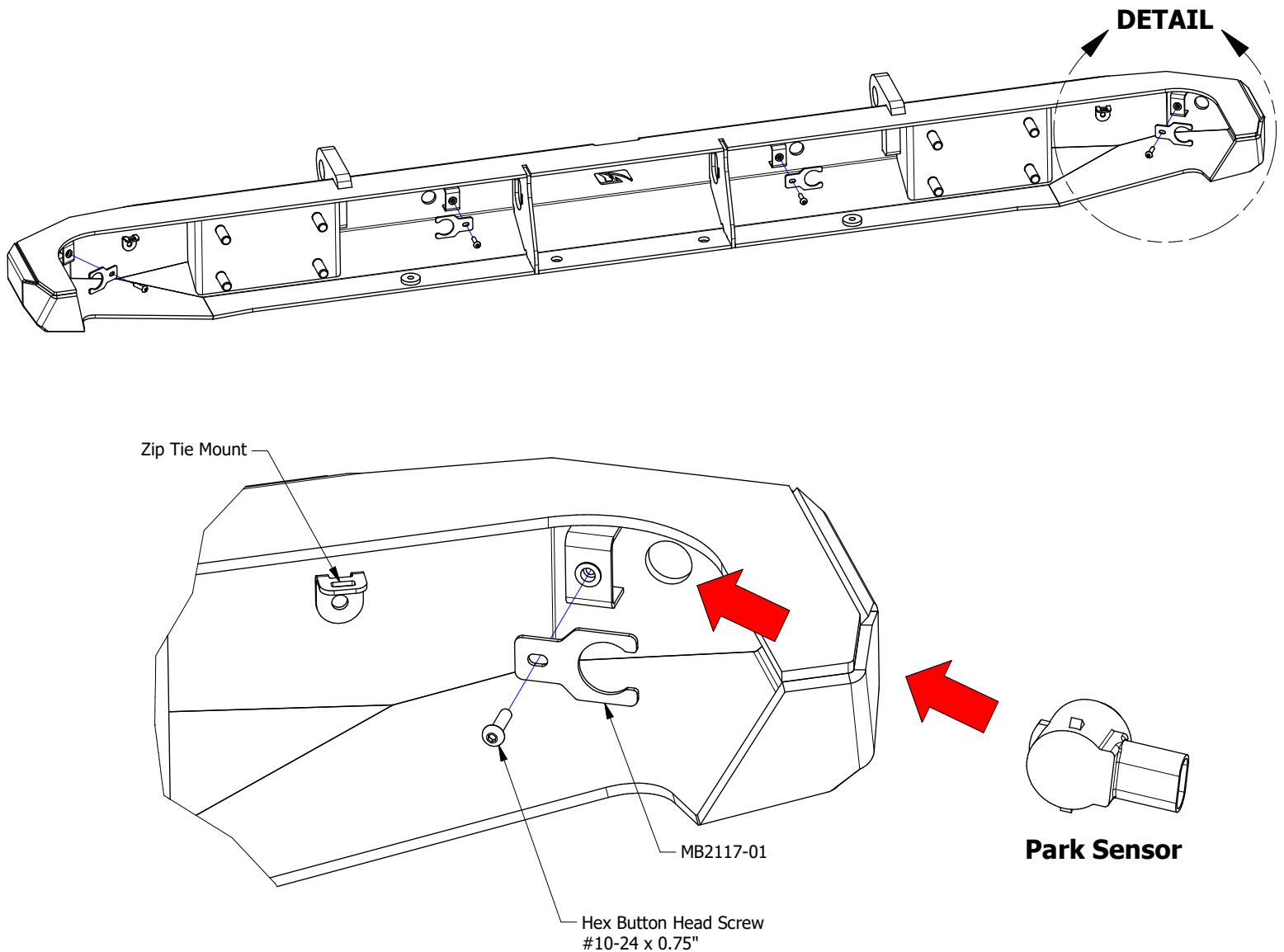

USE BAG LABELED AS
1180

MB1178 - Assembly JT Gladiator Bobbed Bed

BUMPER ASSEMBLY STEP 5A

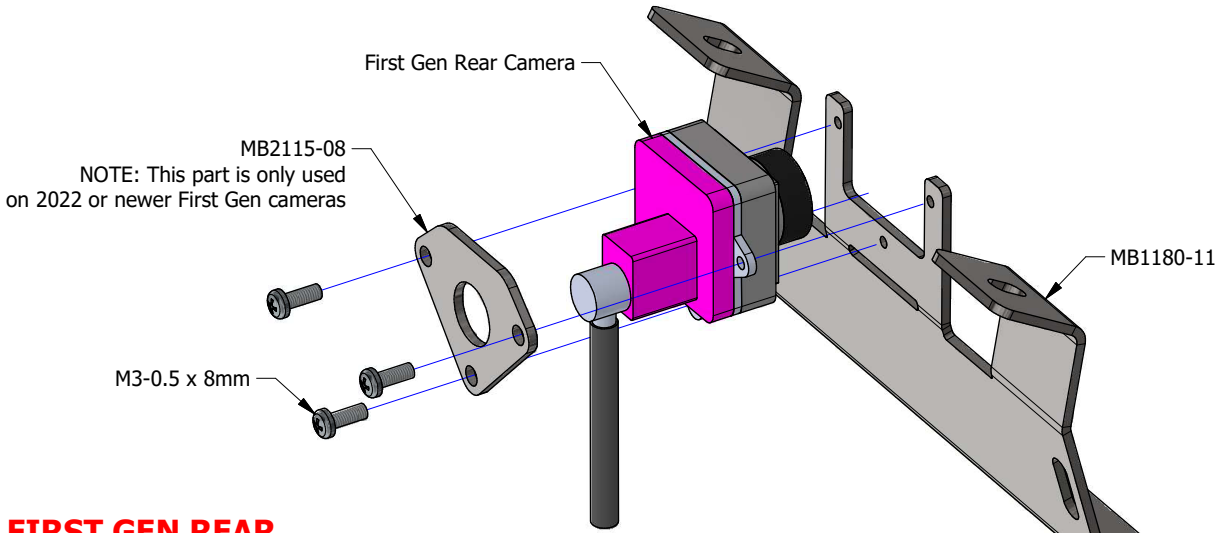

FIRST GEN REAR CAMERA SHOWN

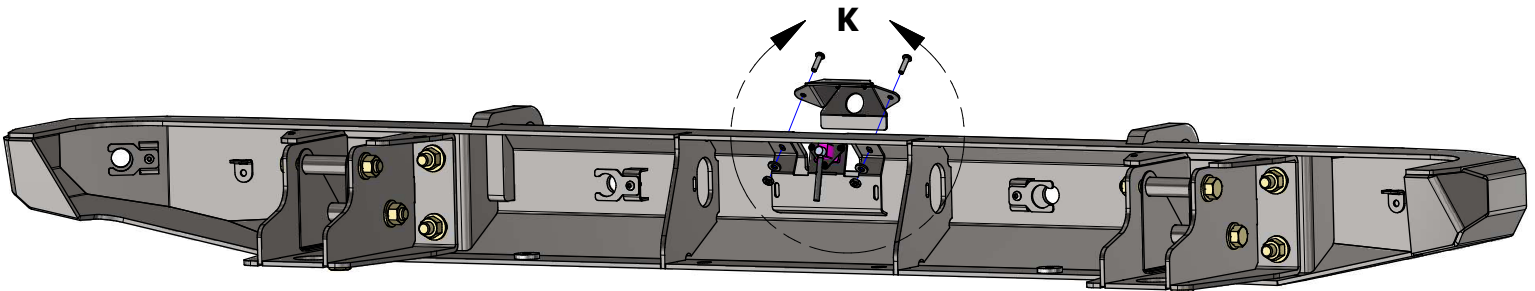
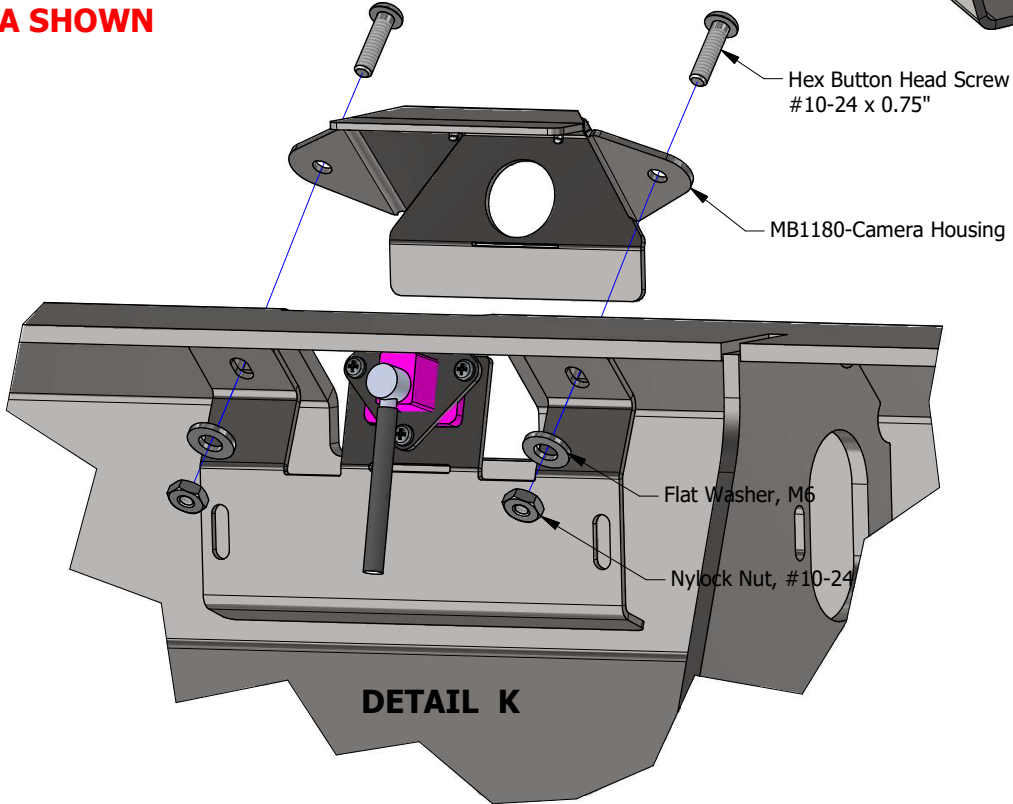

USE BAG LABELED AS
1180

MB1178 - Assembly JT Gladiator Bobbed Bed

BUMPER ASSEMBLY STEP 5B

**SECOND GEN REAR
CAMERA SHOWN**

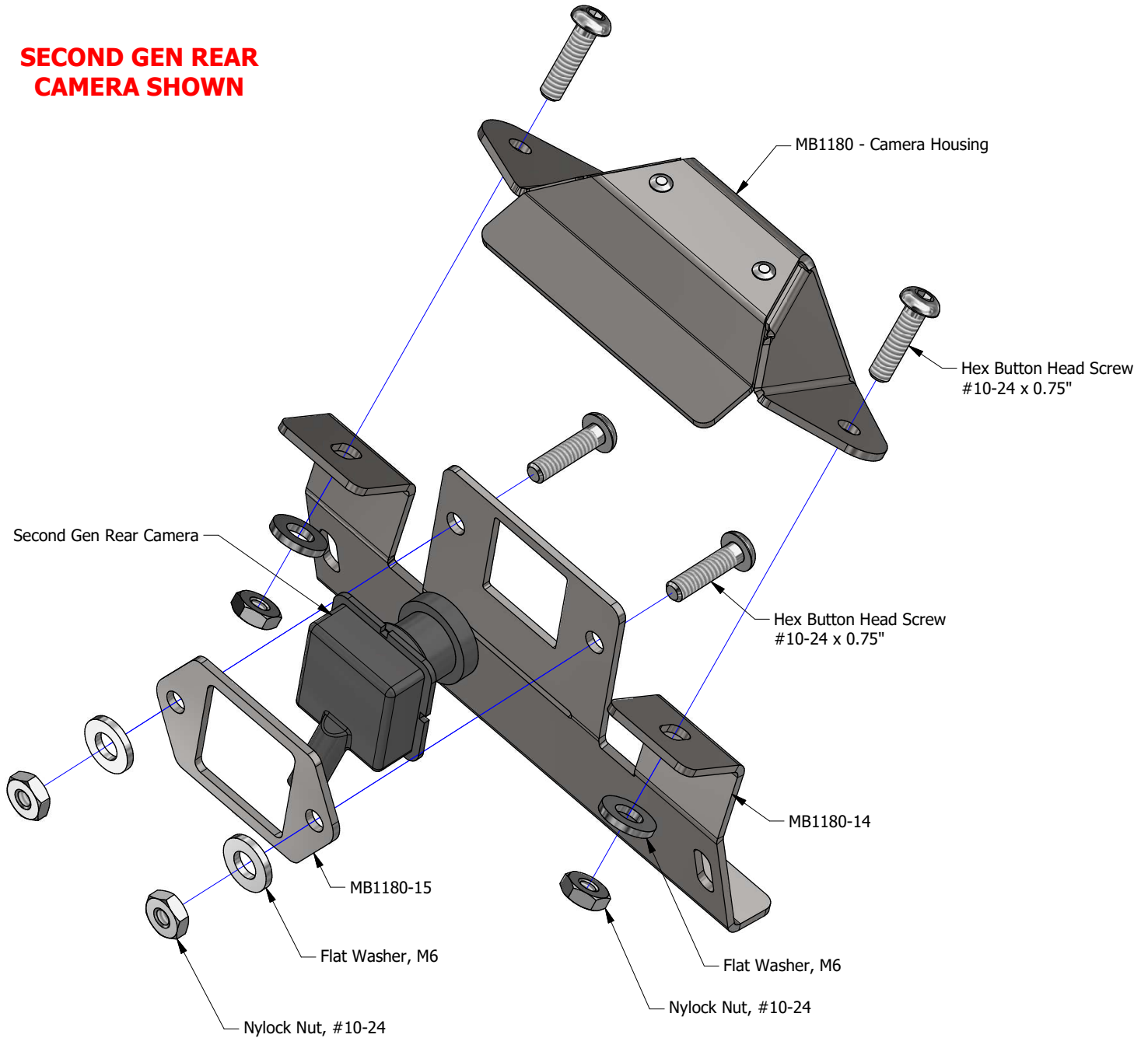

MB1178 - Assembly JT Gladiator Bobbed Bed

BUMPER ASSEMBLY STEP 6

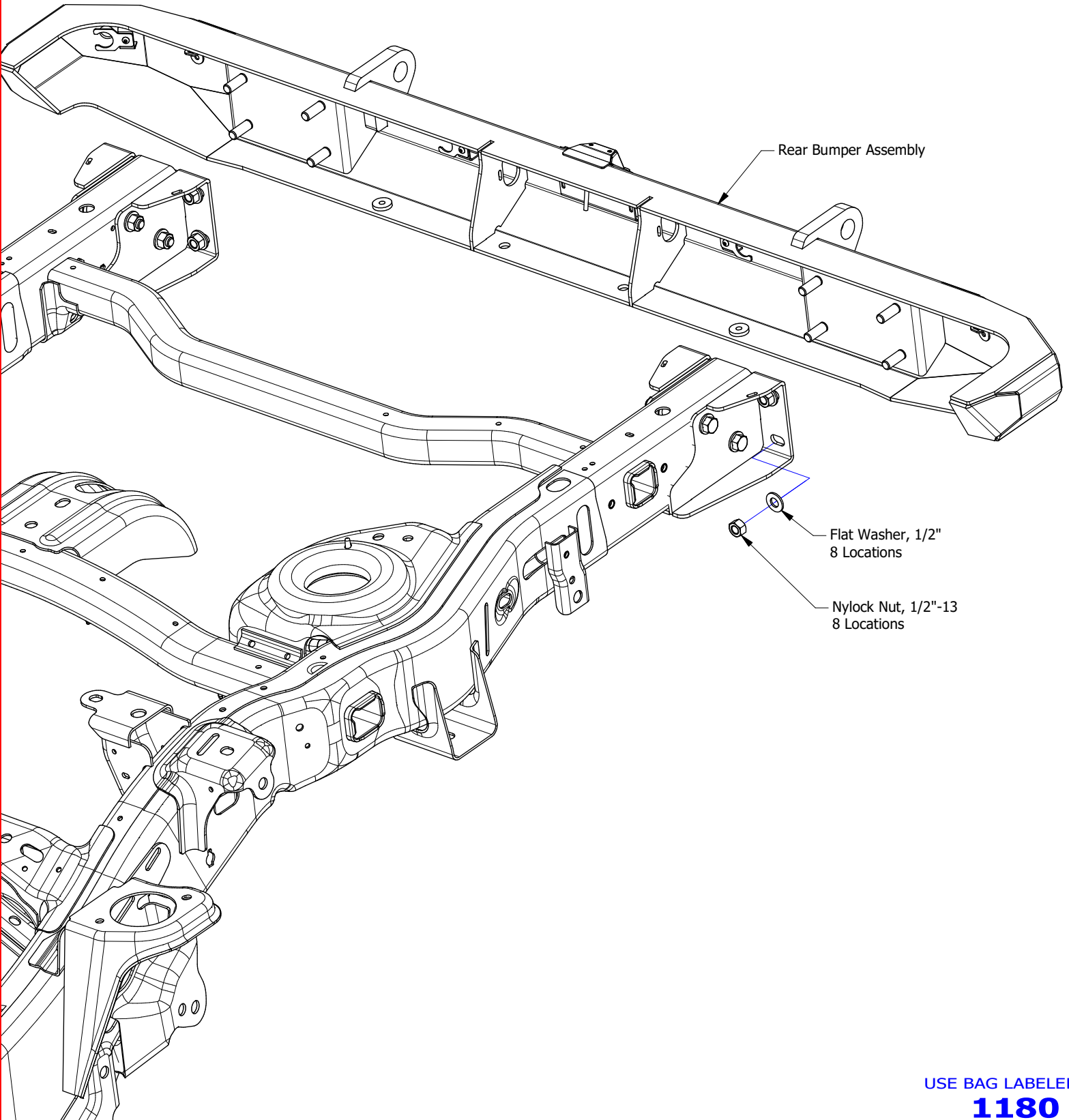

USE BAG LABELED AS
1180

MB1178 - Assembly JT Gladiator Bobbed Bed

BED ASSEMBLY STEP 1

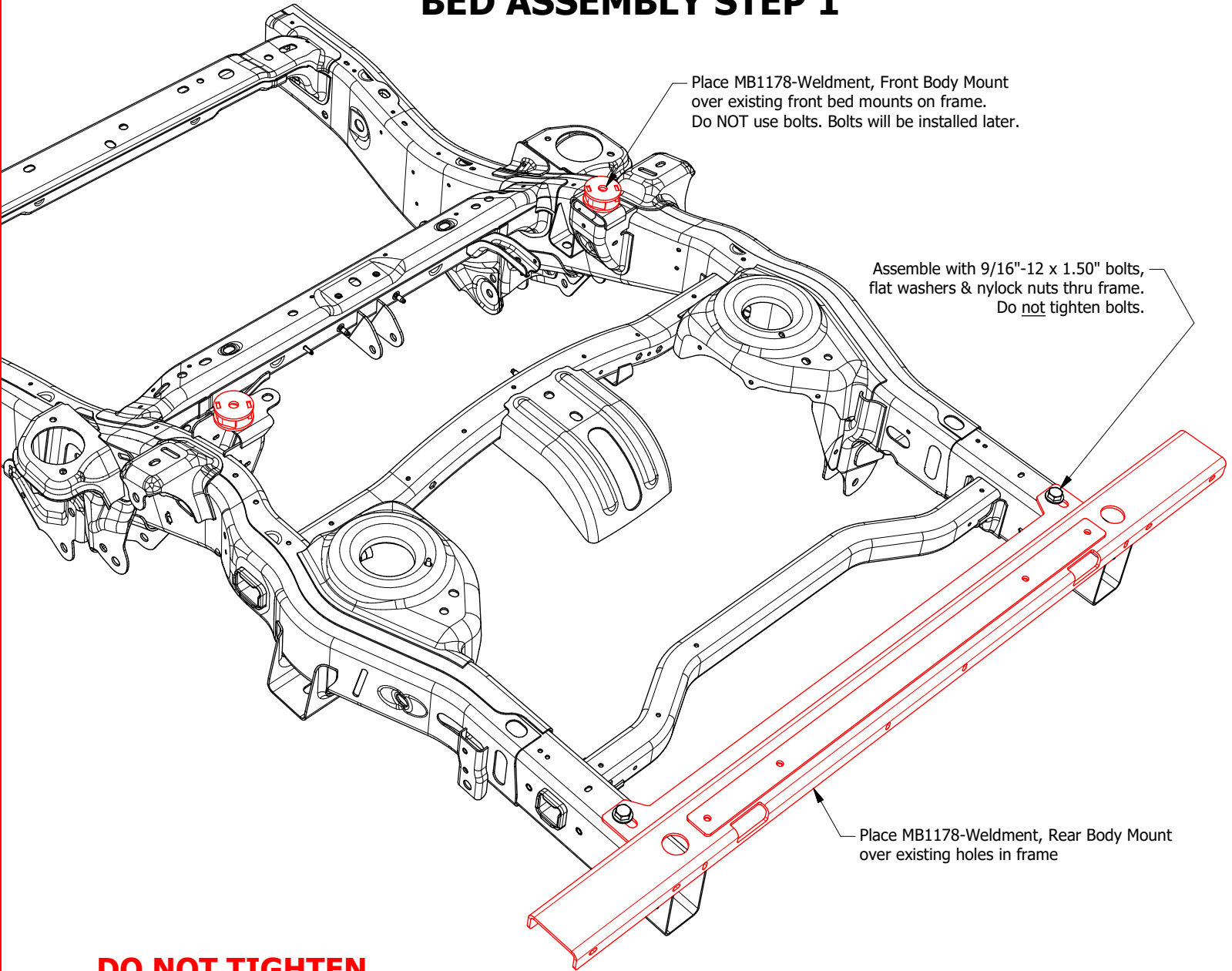

**DO NOT TIGHTEN
FASTENERS**

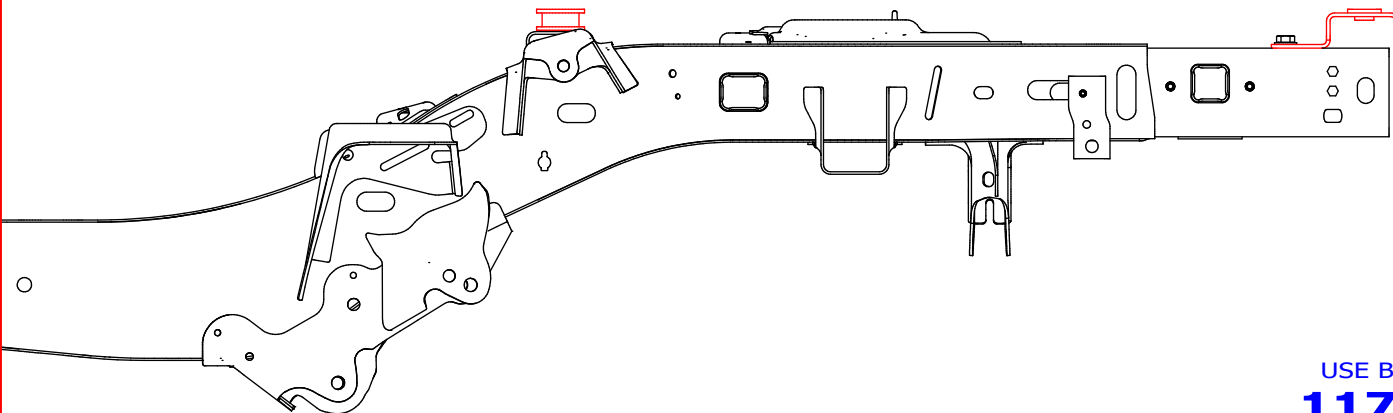

USE BAG LABELED AS
1178-KIT01

MB1178 - Assembly JT Gladiator Bobbed Bed

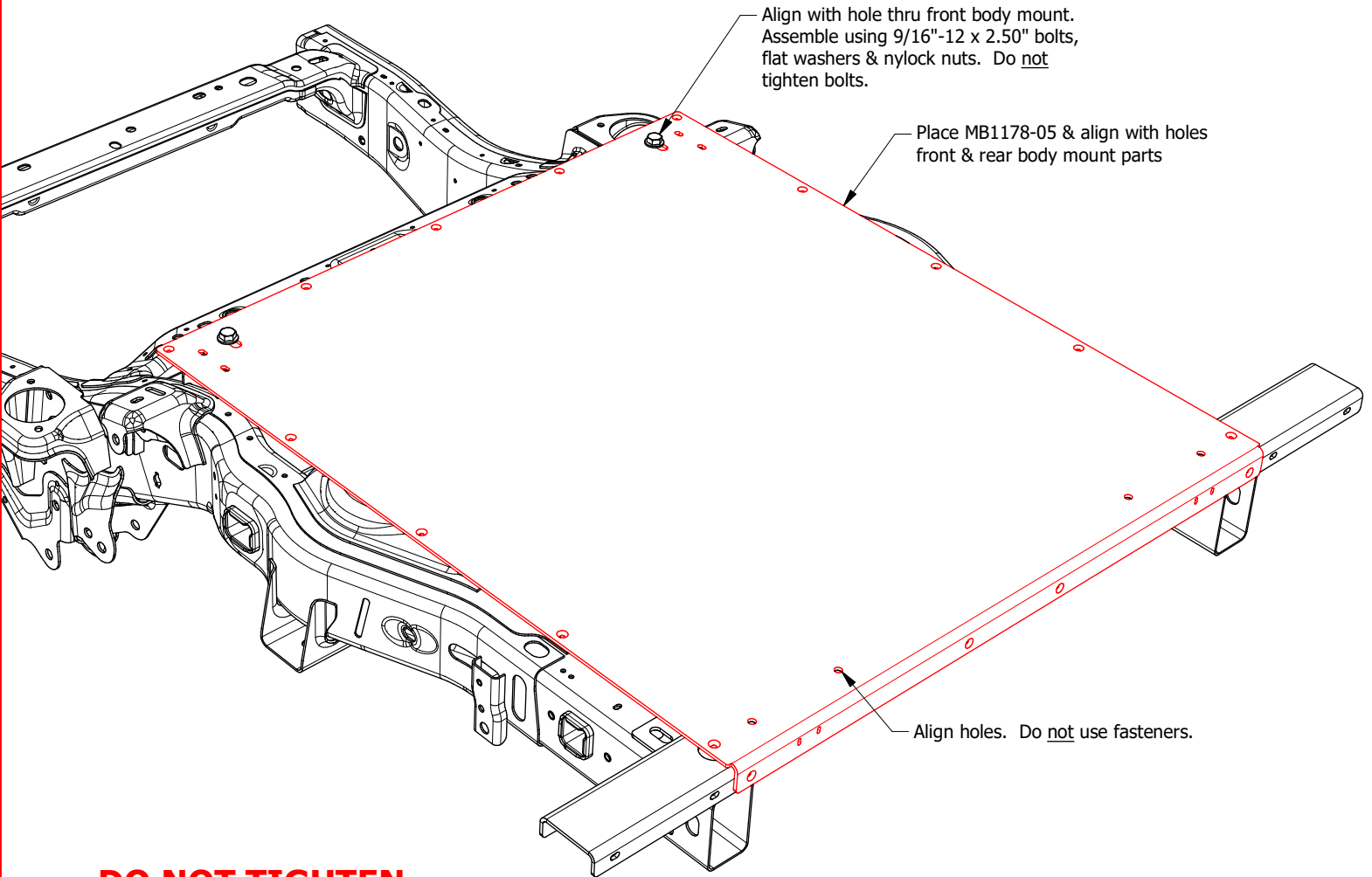
BED ASSEMBLY STEP 2

**DO NOT TIGHTEN
FASTENERS**

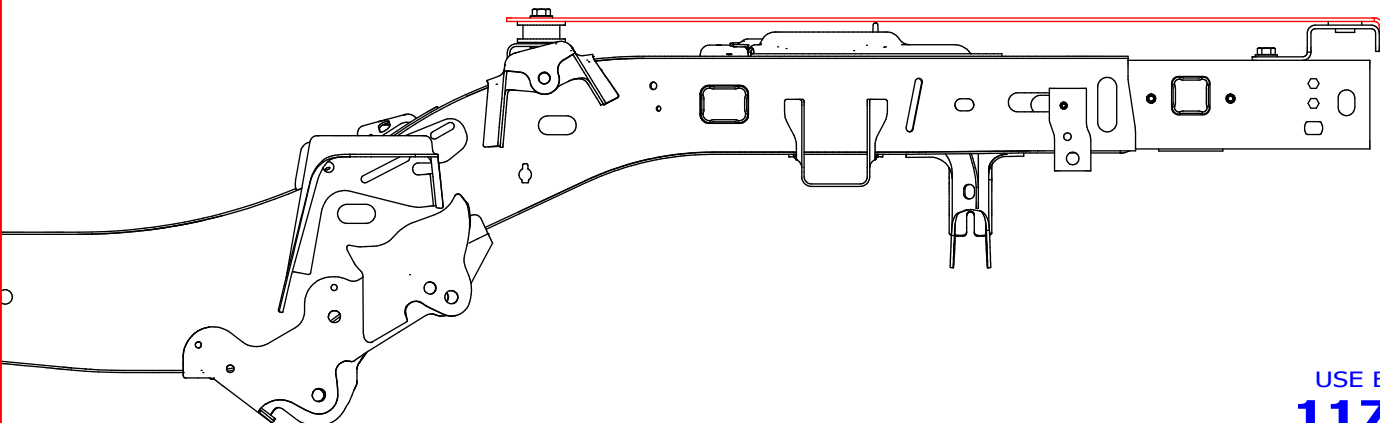

USE BAG LABELED AS
1178-KIT01

MB1178 - Assembly JT Gladiator Bobbed Bed

BED ASSEMBLY STEP 3

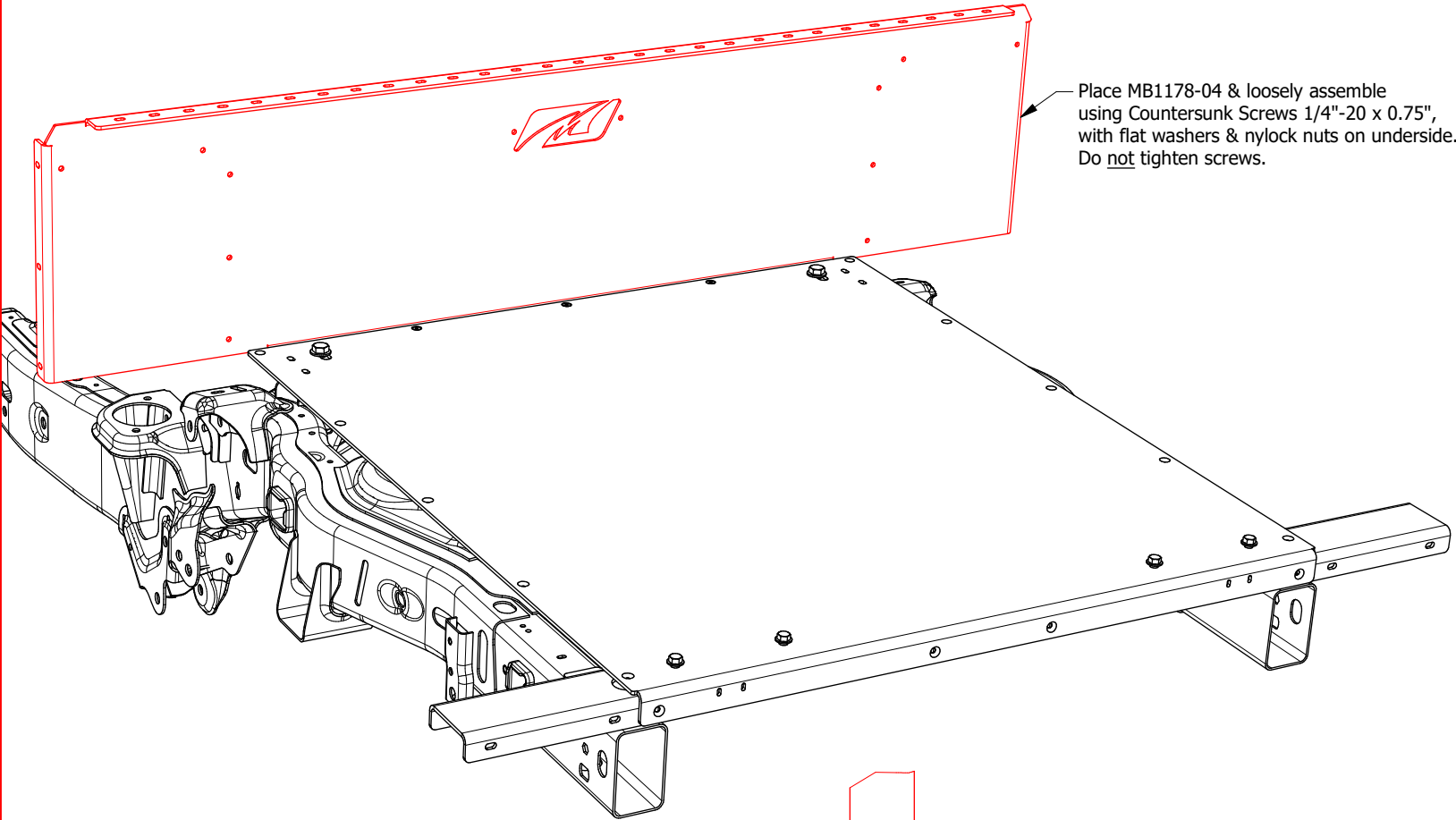

DO NOT TIGHTEN FASTENERS

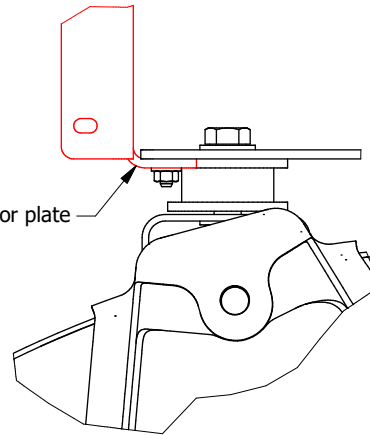

DETAIL A

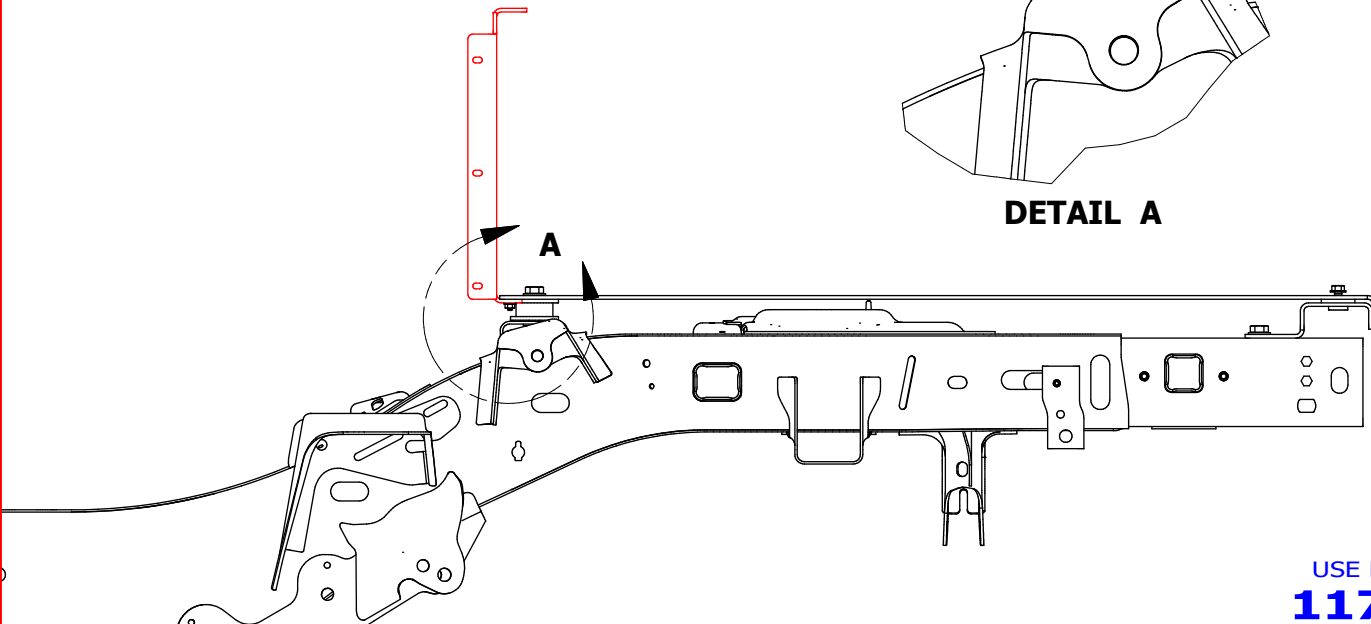

USE BAG LABELED AS
1178-KIT02

MB1178 - Assembly JT Gladiator Bobbed Bed

BED ASSEMBLY STEP 4

**DO NOT TIGHTEN
FASTENERS**

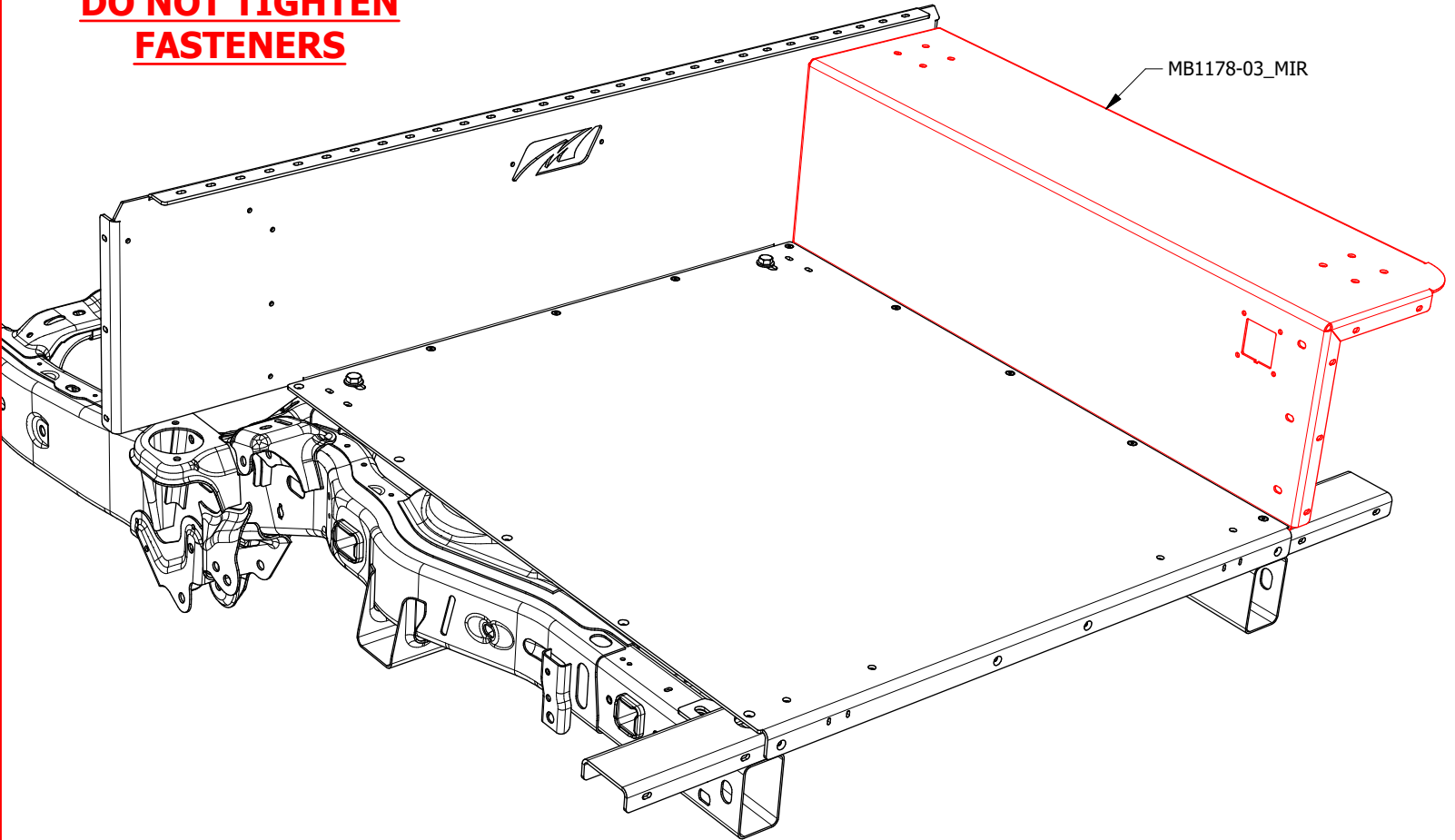

MB1178-03_MIR

Countersunk Screw 1/4"-20 x 0.75",
flat washer & nylock nut thru floor
plate. Do not tighten.

Hex Bolt 1/4"-20 x 0.75",
flat washer & nylock nut.
Do not tighten.

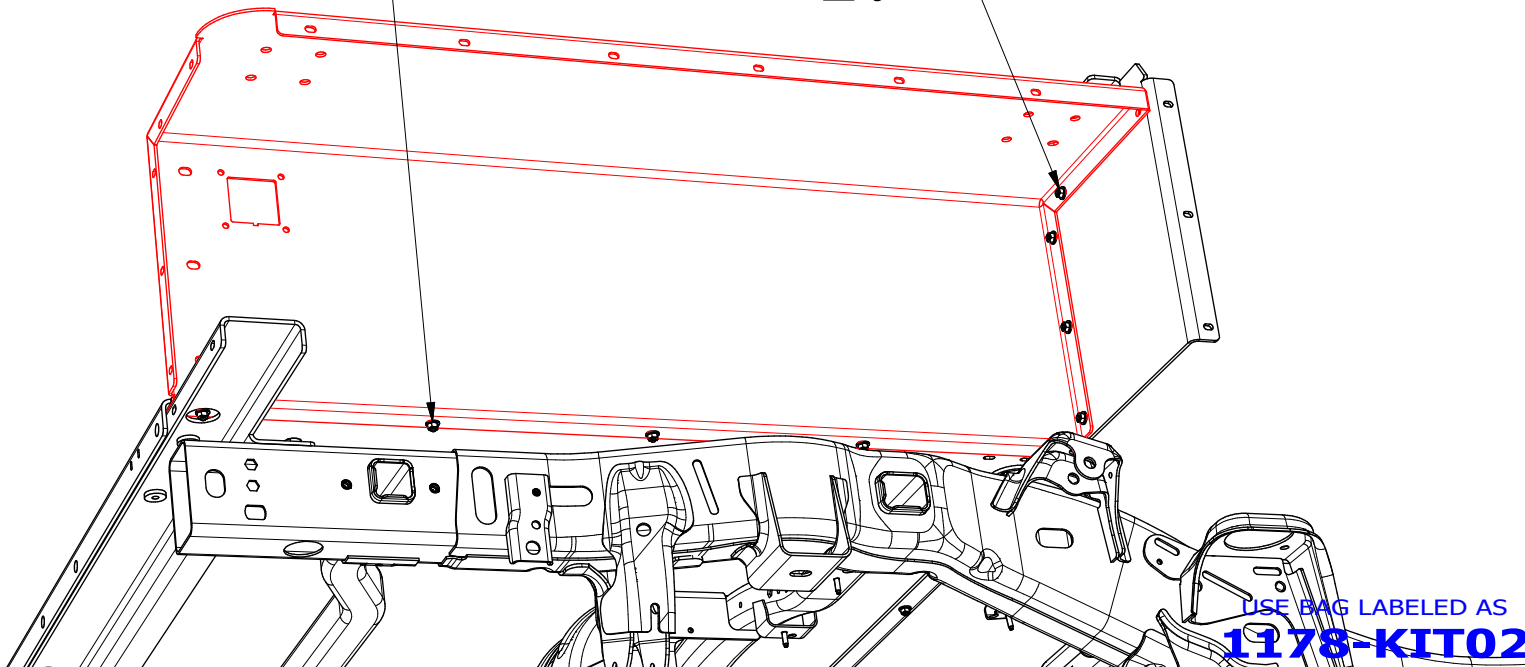

USE BAG LABELED AS
1178-KIT02

MB1178 - Assembly JT Gladiator Bobbed Bed

BED ASSEMBLY STEP 5

MB1178 - Weldment, Fender Passenger

Use Countersunk Screw
1/4"-20 x 1.25" for these
four (4) locations
SEE STEP 14 & 15**DO NOT TIGHTEN
FASTENERS**Countersunk Screw 1/4"-20 x 0.75",
Flat Washers & Nylocks Nuts
(12 Locations)USE BAG LABELED AS
1178-KIT02

MB1178 - Assembly JT Gladiator Bobbed Bed

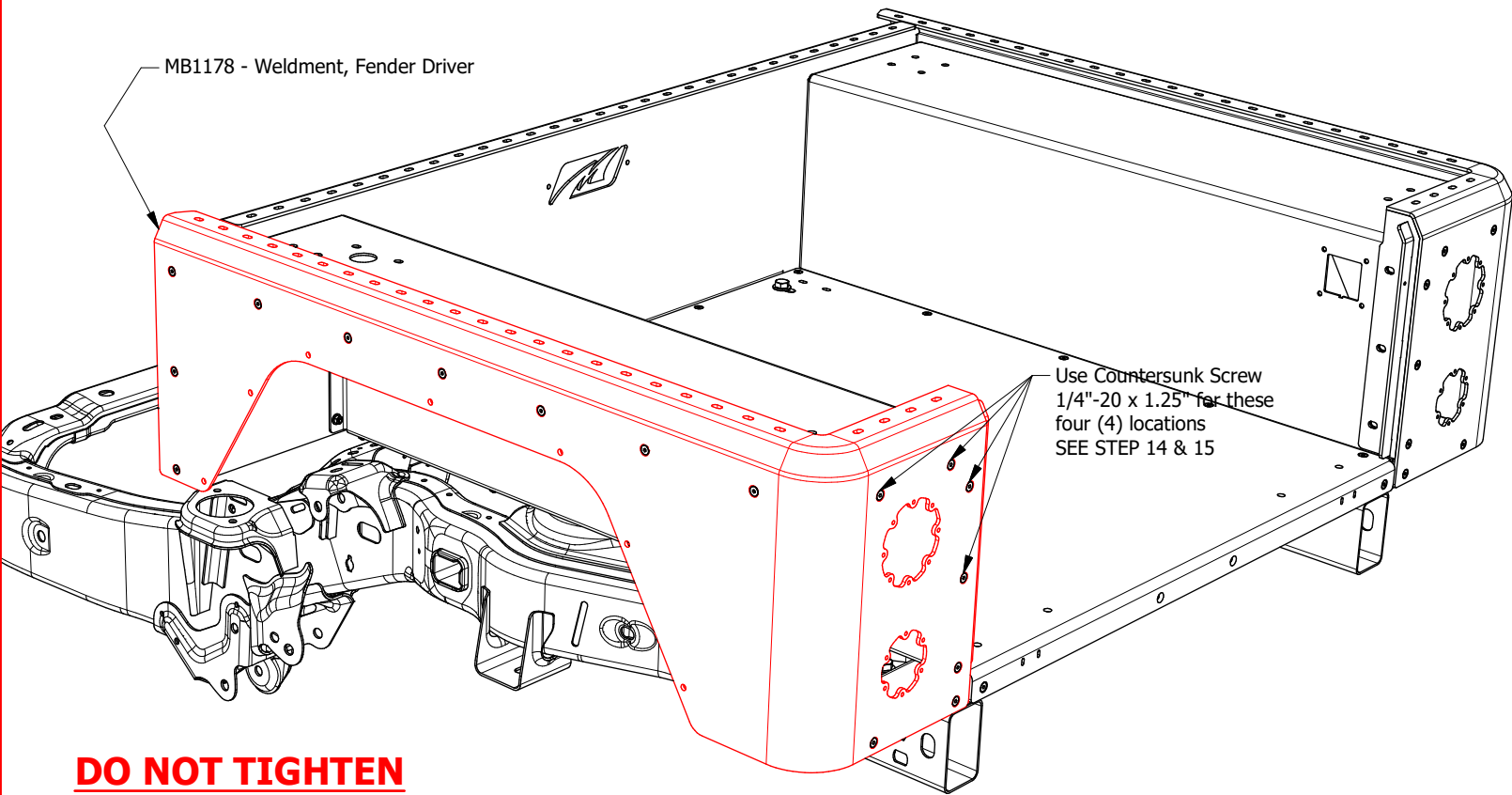
BED ASSEMBLY STEP 6

DO NOT TIGHTEN FASTENERS

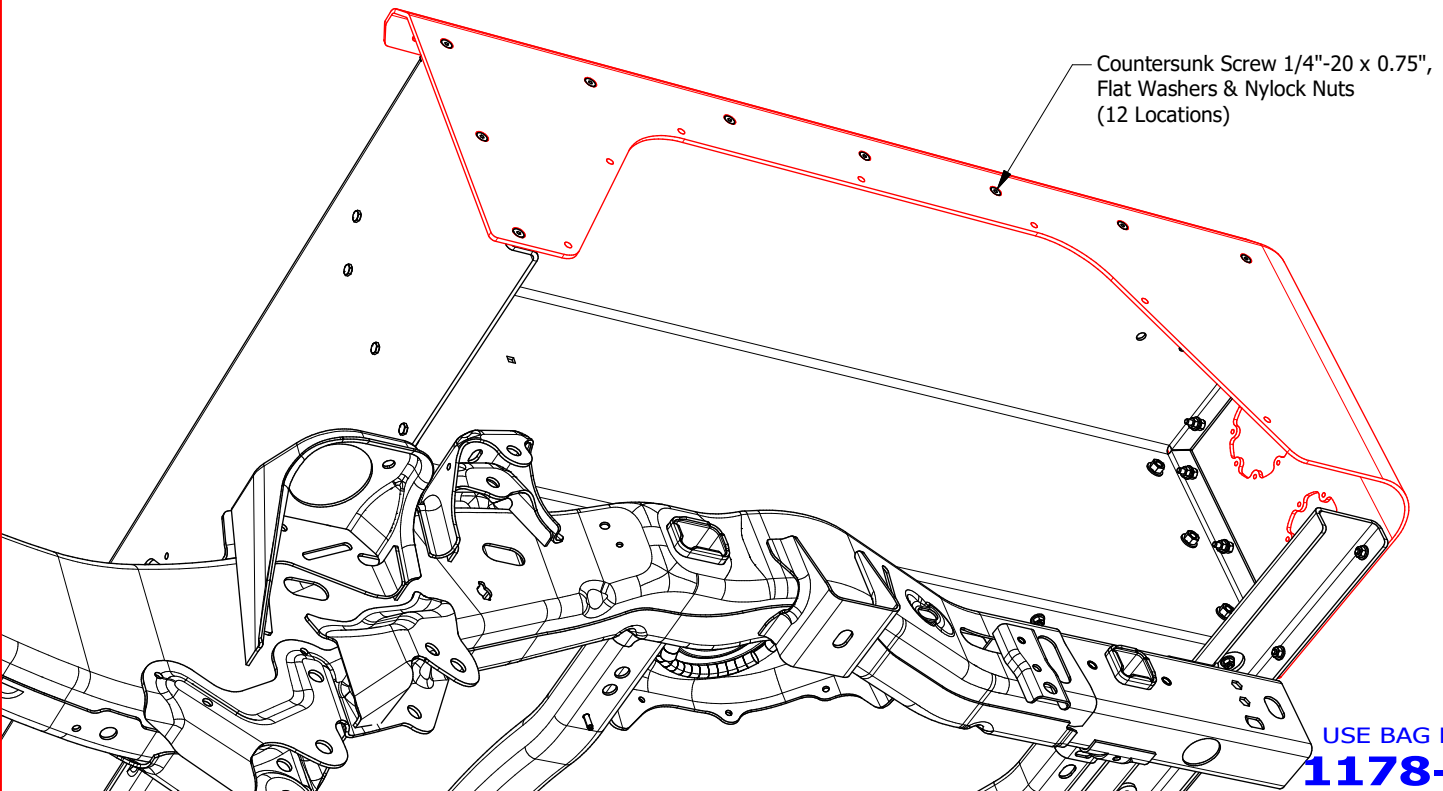

USE BAG LABELED AS
1178-KIT02

MB1178 - Assembly JT Gladiator Bobbed Bed

BED ASSEMBLY STEP 7

**DO NOT TIGHTEN
FASTENERS**

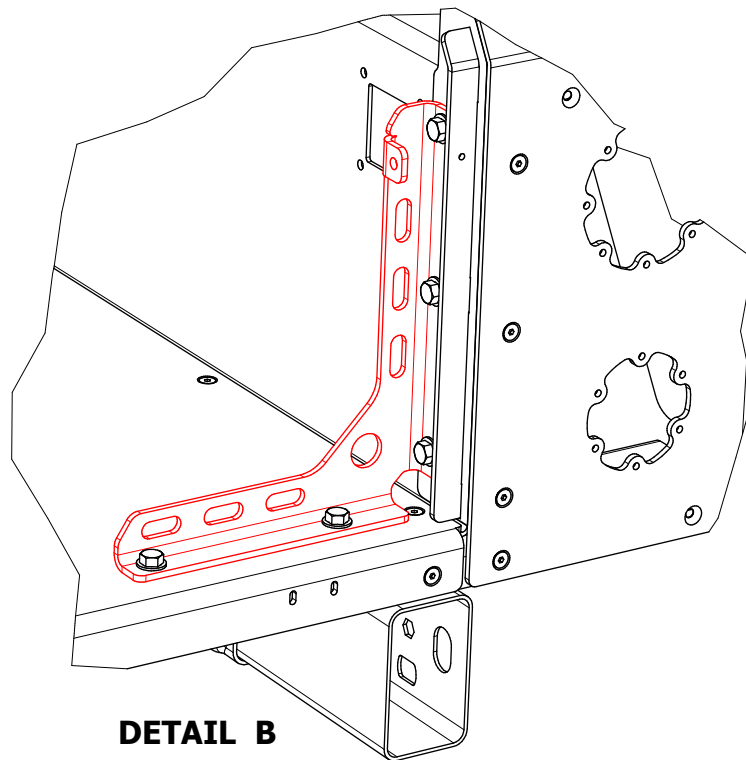
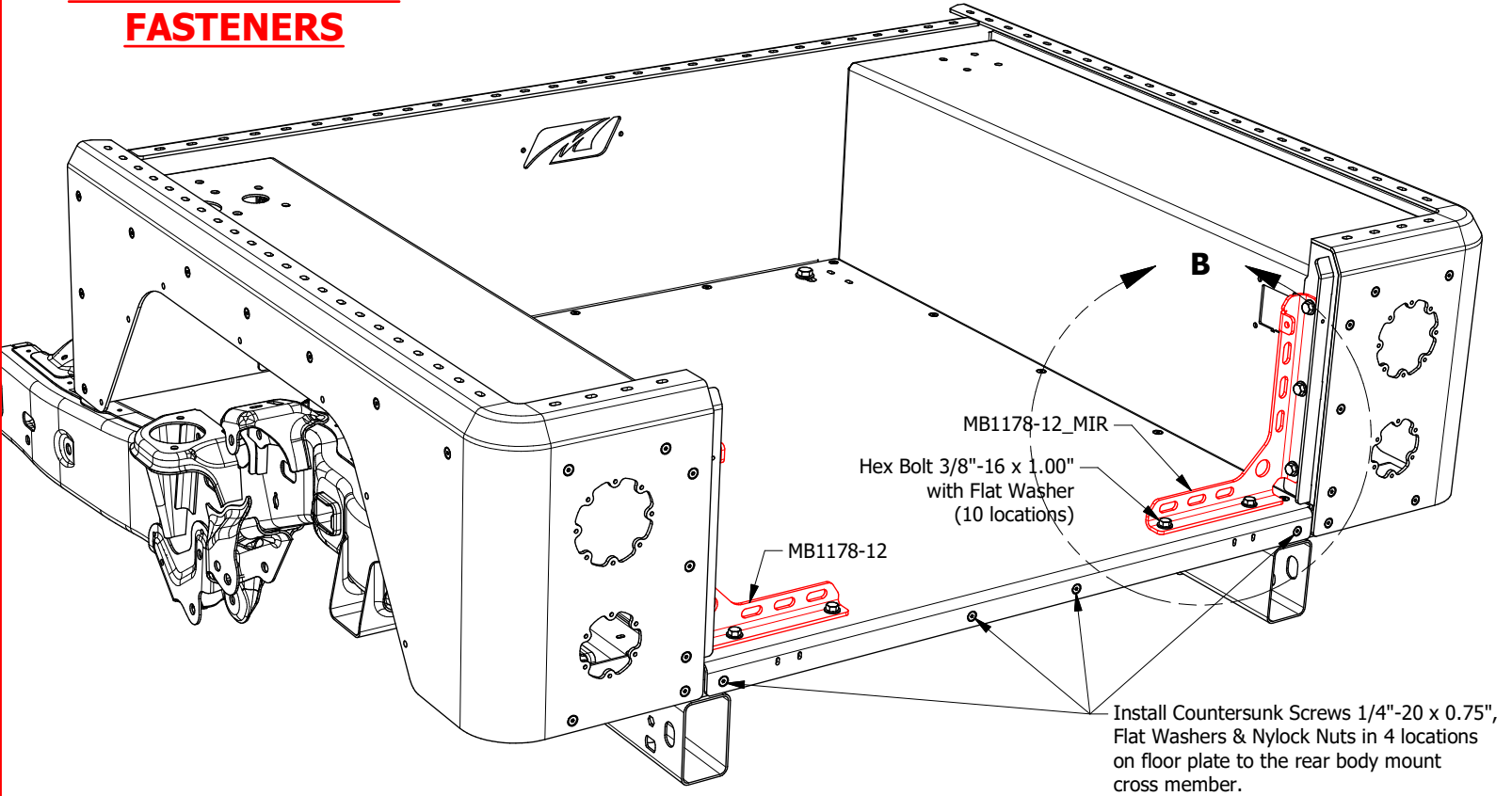

USE BAG LABELED AS
1178-KIT03

MB1178 - Assembly JT Gladiator Bobbed Bed

BED ASSEMBLY STEP 8

HOW TO SQUARE THE TAILGATE OPENING

Place a ratchet strap between the tail light openings. Place a carpenter's square between the floor plate & vertical plate of the outer fender. Tighten ratchet strap until square. Check both the left & right fenders for square.

Tighten the 3/8" bolts for #MB1178-12 & #MB1178-12_MIR (from Step 07) starting with the bolts going through the floor plates, then the vertical bolts going through the outer & inner fenders.



Measure the lower inside distance between the outer fenders.

Measure the upper inside distance between the outer fenders.

If both measurements are equal & the outer fenders are square to the floor plate, then **tighten all fasteners installed up to this point EXCEPT the fasteners securing the bed the frame.**

If both measurements are NOT equal, then you will need to check your squaring from above & adjust accordingly.



MB1178 - Assembly JT Gladiator Bobbed Bed

BED ASSEMBLY STEP 9

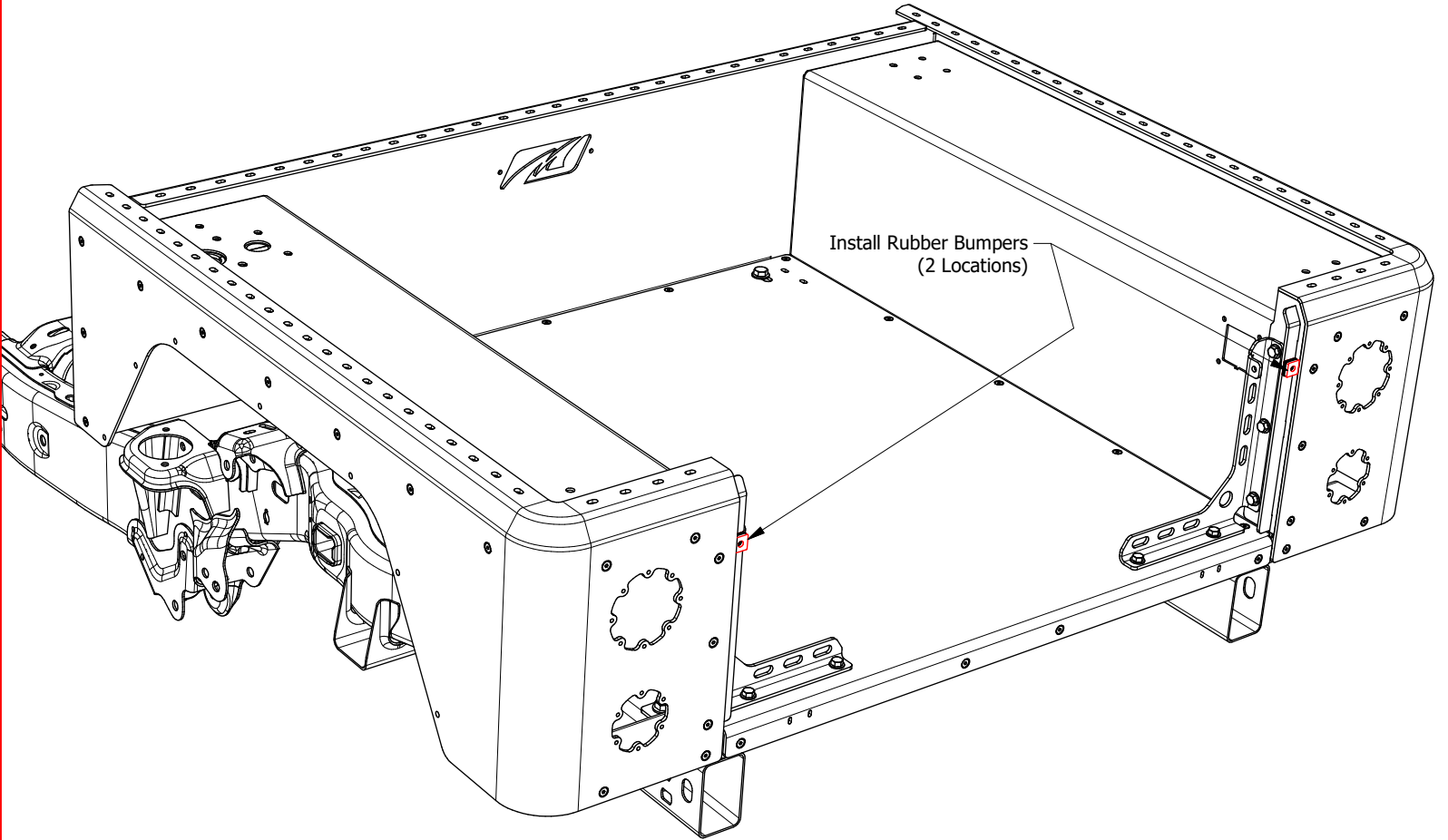

**TIGHTEN
FASTENERS**

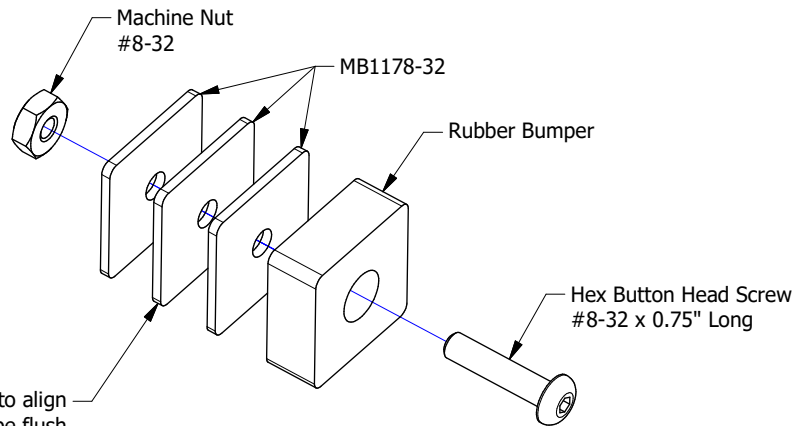

Use as many spacers as you need to align the outside edge of the tail gate to be flush with outside edge of the rear outer fenders.

USE BAG LABELED AS
1178-KIT04

MB1178 - Assembly JT Gladiator Bobbed Bed

BED ASSEMBLY STEP 10



Place the Tailgate MB1178-02 in the opening. Clamp so the top edge of Tailgate is flush with the top of the outer fenders (see photo). Driver side shown. Repeat for passenger side.

Adjust the Tailgate left or right until the reveal between the Tailgate & the fenders are equal on both sides.

Install Tailgate hinges & fasteners. Tighten all fasteners for hinges.

Test function of hinges by opening the Tailgate. Adjust hinges if necessary.

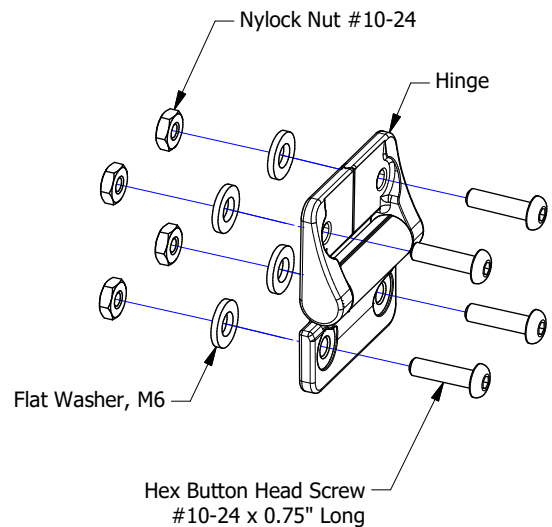

TIGHTEN
FASTENERS

USE BAG LABELED AS
1178-KIT05

MB1178 - Assembly JT Gladiator Bobbed Bed

BED ASSEMBLY STEP 11

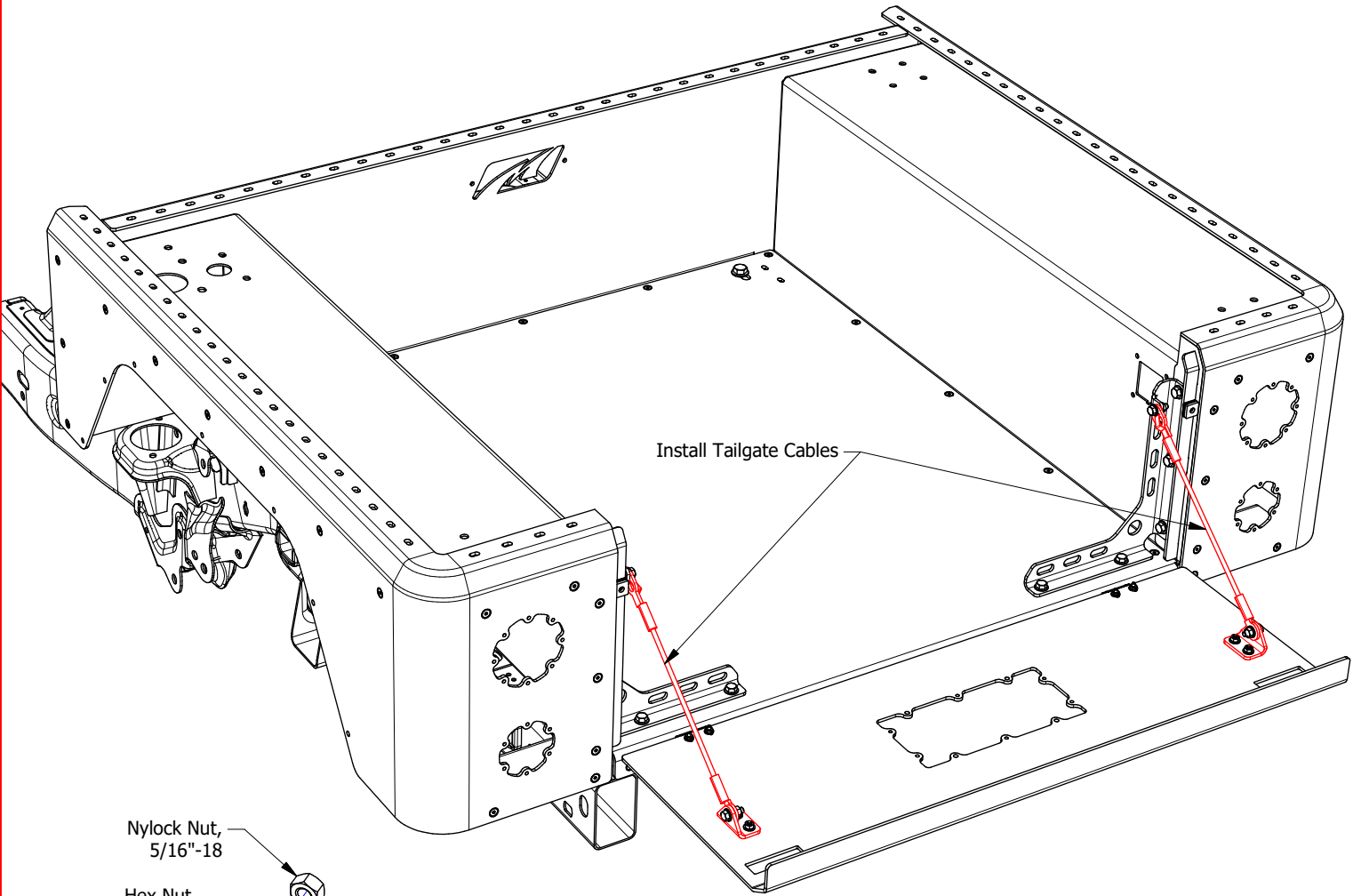

Nylock Nut,
5/16"-18

Hex Nut,
5/16"-18

NOTE:
Install Hex Nut first, then Nylock Nut second.
Ensure cable can still pivot, then tighten both
nuts together.

Flat Washer, 5/16"

Hex Bolt,
5/16"-18 x 1.00"

Tailgate Cable

Flat Washer, 1/4"

Nylock Nut,
1/4"-20

Hex Bolt,
5/16"-18 x 1.00"

Flat Washer, 5/16"

MB1178-26

MB1178-25
Cable Eye Spacer

Flat Washer, 5/16"

Countersunk Screw,
1/4"-20 x 0.75"

Nylock Nut,
5/16"-18

**TIGHTEN
FASTENERS**

**Tailgate Cable Assembly
(2 Locations)**

USE BAG LABELED AS
1178-KIT06

MB1178 - Assembly JT Gladiator Bobbed Bed

BED ASSEMBLY STEP 12

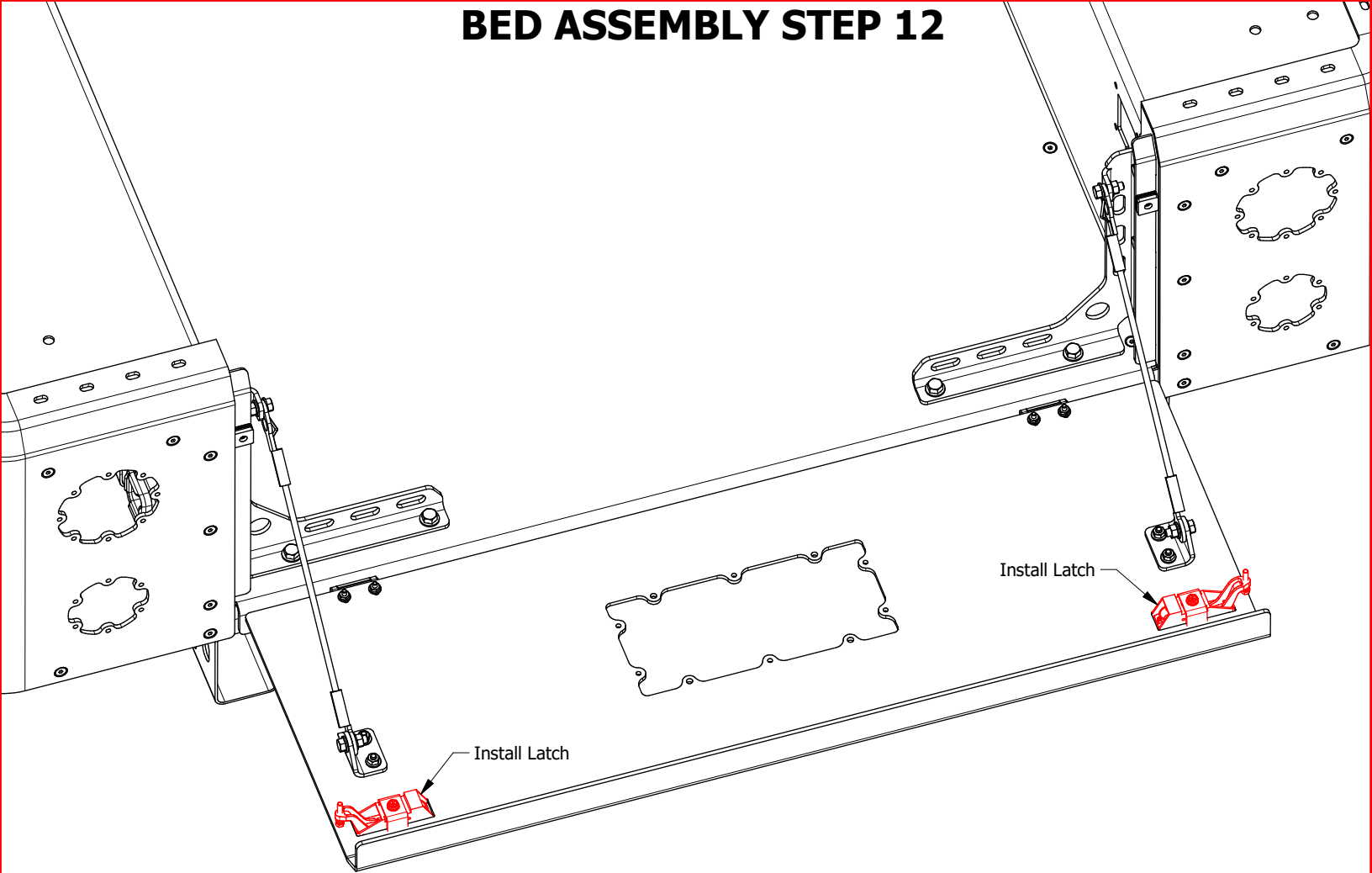

**TIGHTEN
FASTENERS**

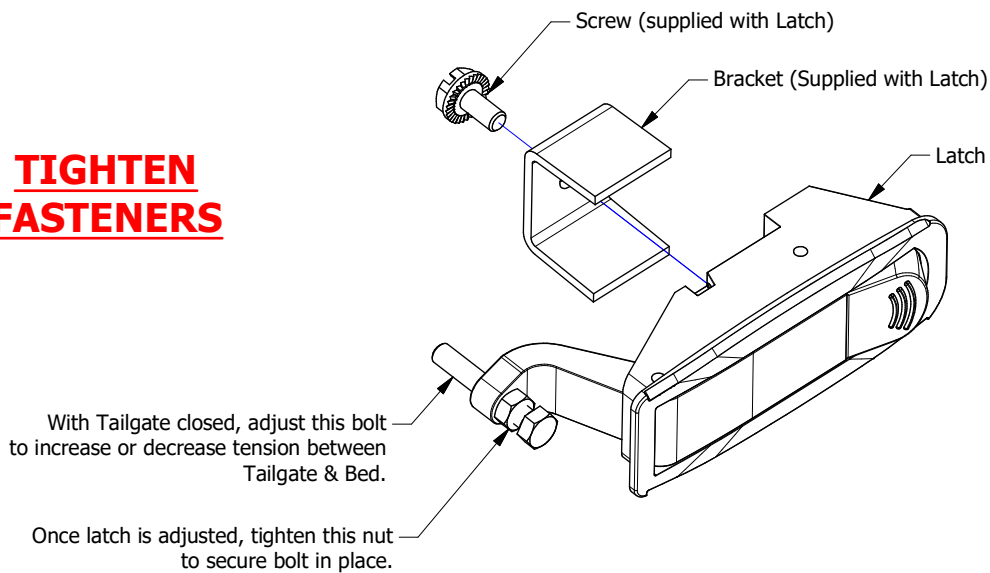

**Latch Assembly
(2 Locations)**

USE BAG LABELED AS
1178-KIT07

MB1178 - Assembly JT Gladiator Bobbed Bed

BED ASSEMBLY STEP 13

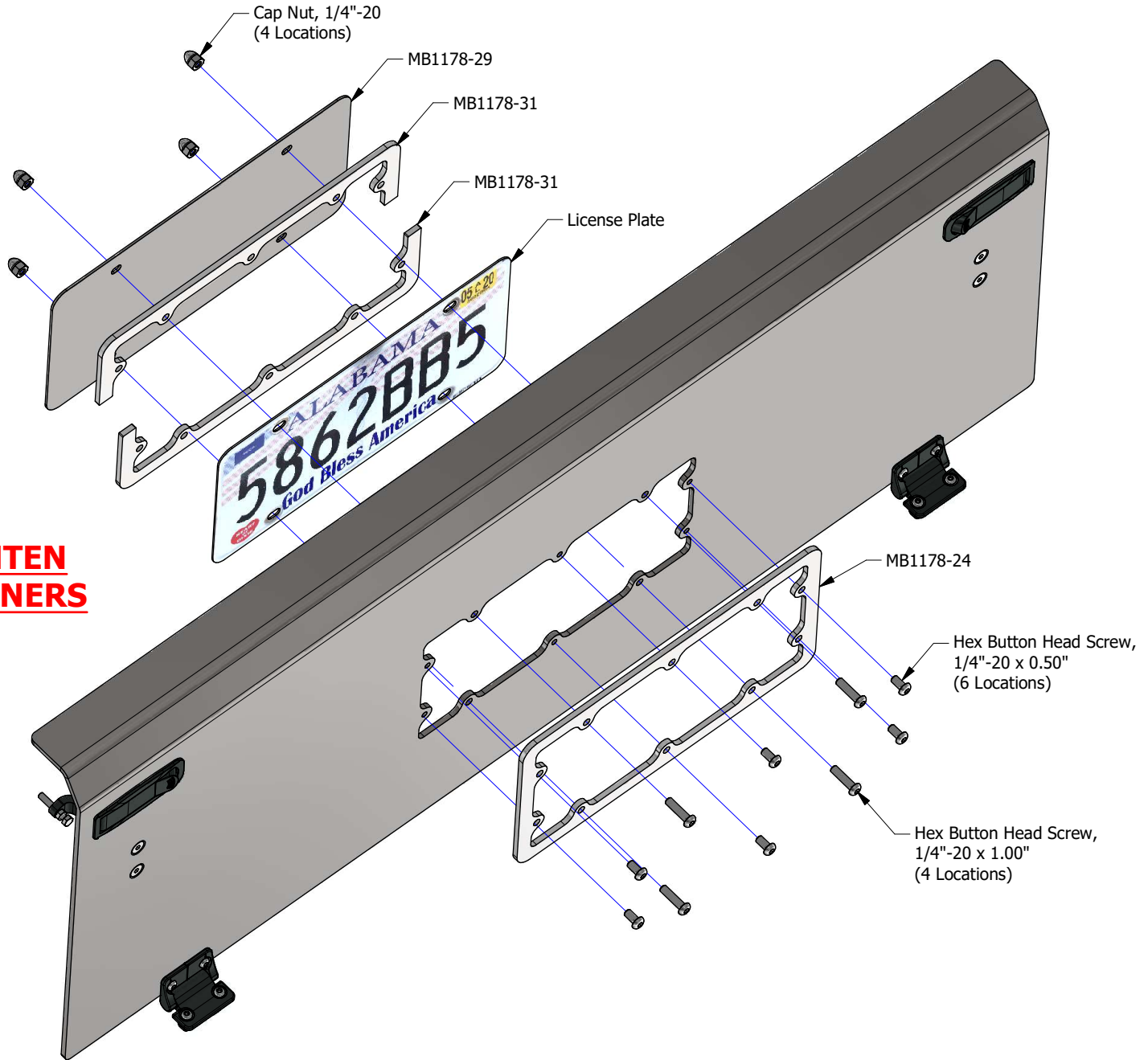

License Plate Assembly

USE BAG LABELED AS
1178-KIT08

MB1178 - Assembly JT Gladiator Bobbed Bed

BED ASSEMBLY STEP 14

NOTE: These fasteners bolt through the outer fender to the inner fender. Add the nylock nut to the countersunk screw to secure the fenders together. This nut will also act as a spacer for MB1178-22. The countersunk screw is extra long. Place MB1178-22 over the extended portion of the screw then fasten with the flat washer & nylock nut.

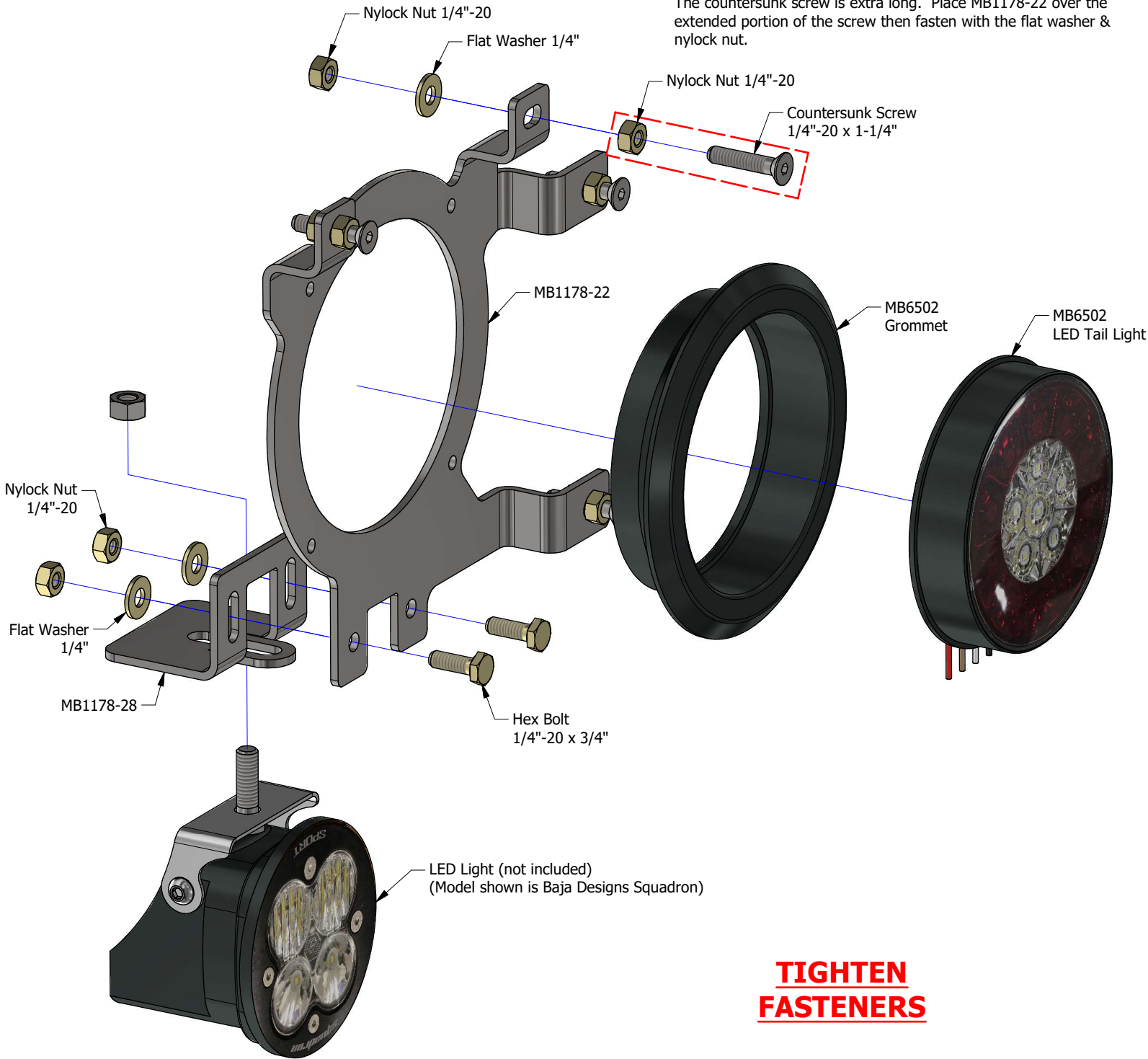

TIGHTEN
FASTENERS

USE BAG LABELED AS
1178-KIT09
USE BAG LABELED AS
1178-KIT17

MB1178 - Assembly JT Gladiator Bobbed Bed

BED ASSEMBLY STEP 15

TIGHTEN FASTENERS

NOTE: These fasteners bolt through the outer fender to the inner fender. Add the nylock nut to the countersunk screw to secure the fenders together. This nut will also act as a spacer for MB1178-22. The countersunk screw is extra long. Place MB1178-22 over the extended portion of the screw then fasten with the flat washer & nylock nut.

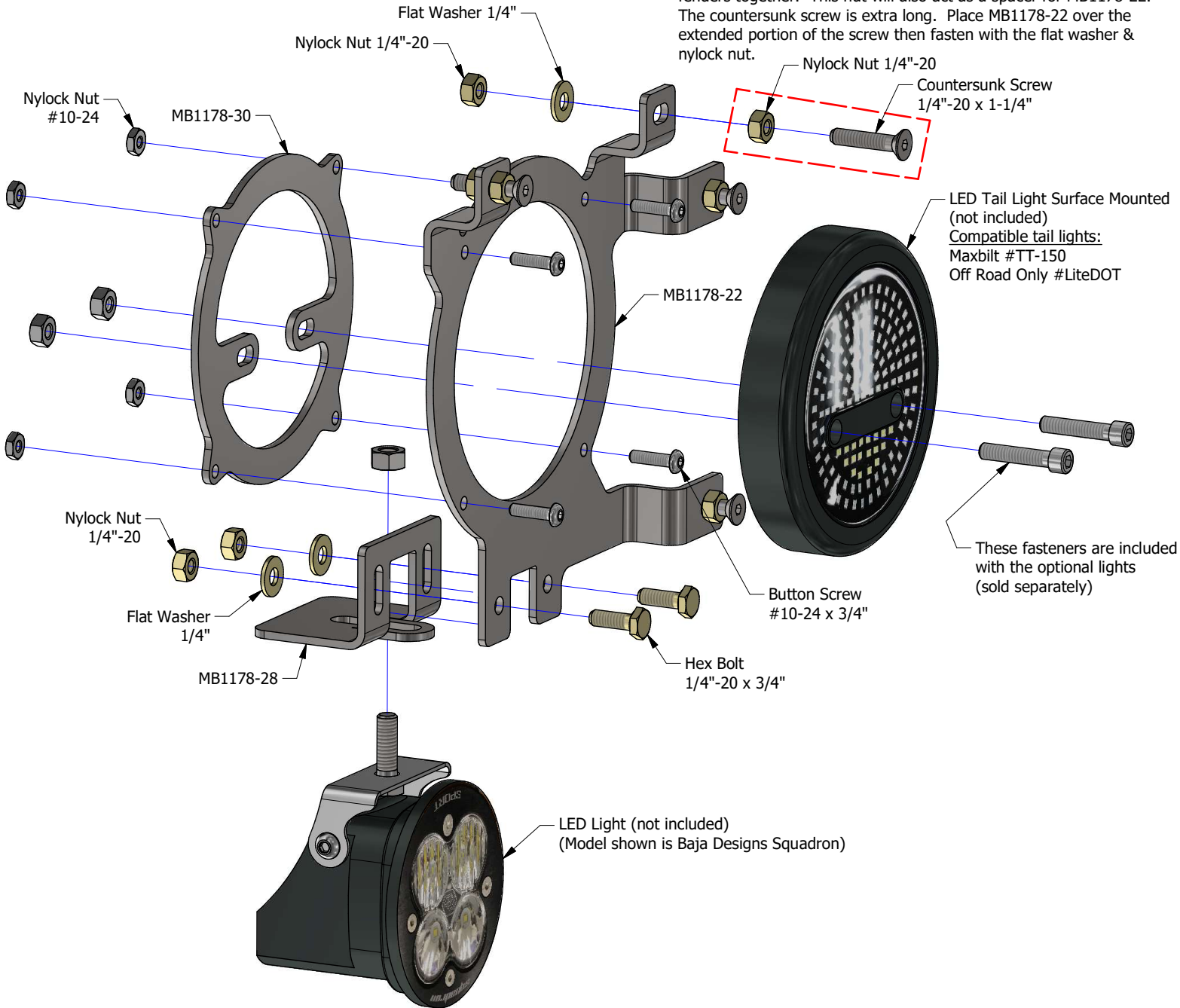

ALTERNATE LIGHT MOUNTING

USE BAG LABELED AS
1178-KIT09
USE BAG LABELED AS
1178-KIT17

MB1178 - Assembly JT Gladiator Bobbed Bed

BED ASSEMBLY STEP 16

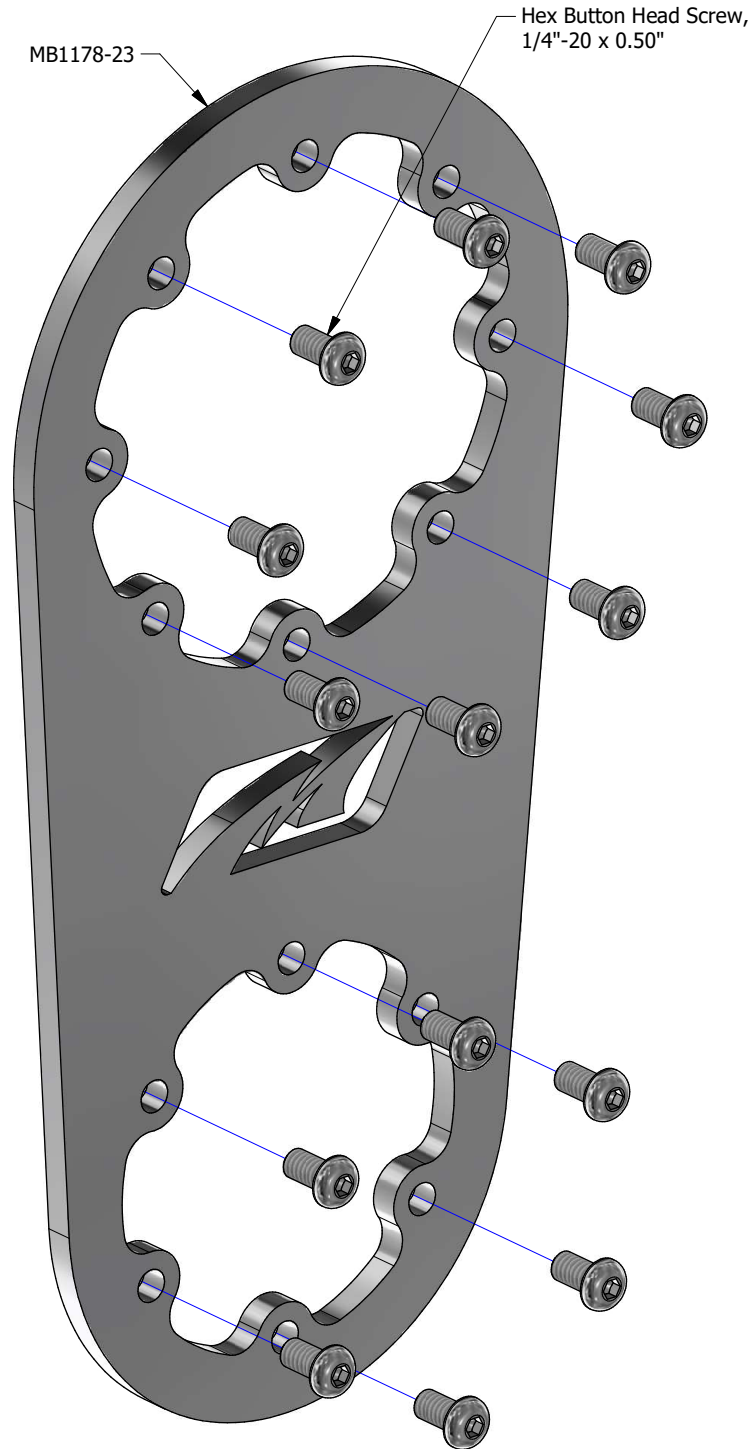
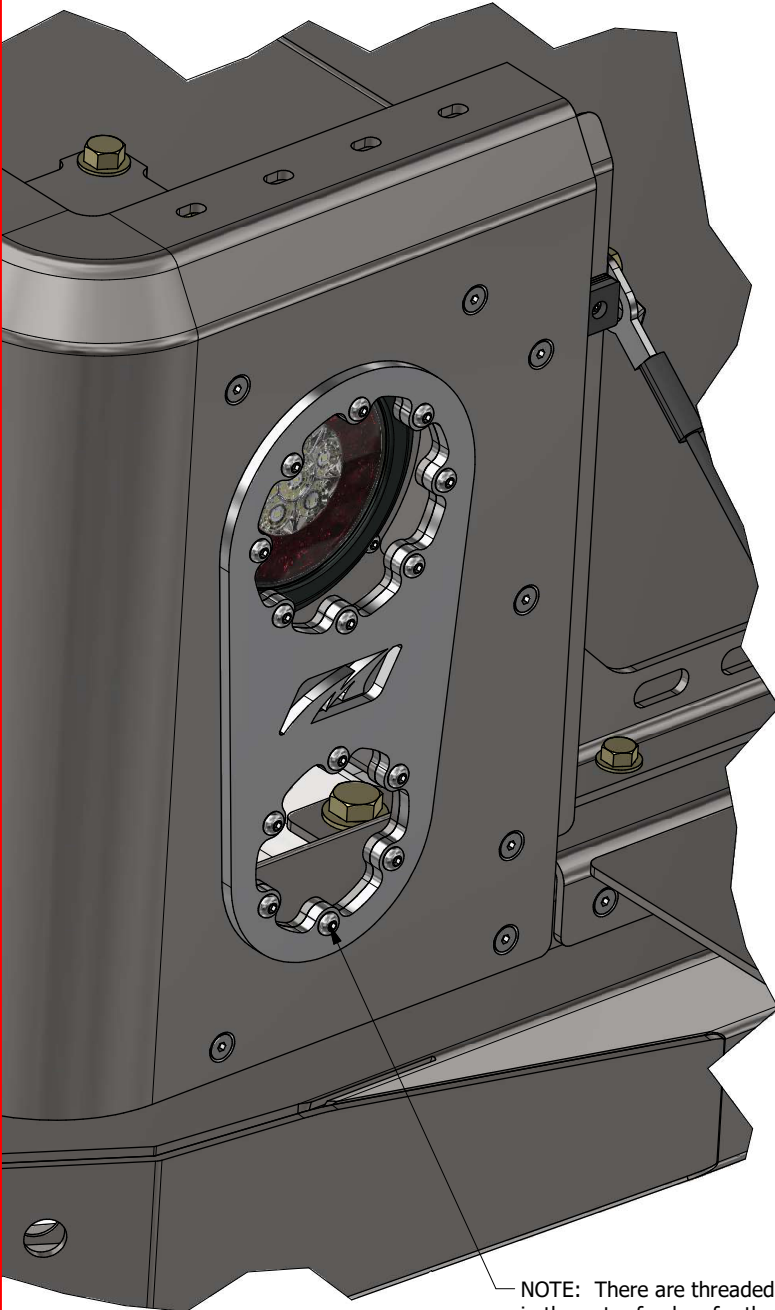

NOTE: There are threaded holes in the outer fenders for the screws to thread in. No nuts required.

**TIGHTEN
FASTENERS**

**EXTERIOR TAIL LIGHT TRIM ASSEMBLY
2 LOCATIONS**

USE BAG LABELED AS
1178-KIT10

MB1178 - Assembly JT Gladiator Bobbed Bed

BED ASSEMBLY STEP 17

This kit includes top & bottom mounting plates for you to add your own removable custom cage, rails or headache rack. The plates are designed for up to 2" O.D. tube. The top plates are mounted to the topside of the inner fenders & are intended to be the mounting points for your custom built cage (or similar). The bottom plates mount to the underside of the inner fenders & are intended for you to tie into the frame of the vehicle. This allows you to remove the custom accessory from the topside for painting, as well as, allows you to remove the underside mounted frame supports for painting & ease of future installation.

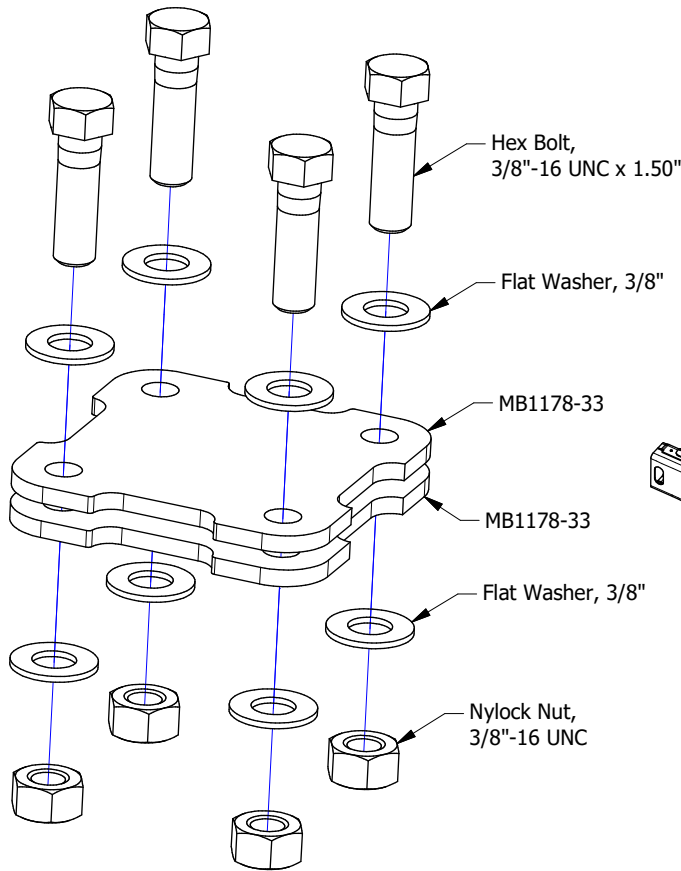

**Cage Plate Assembly
(3 Locations)**

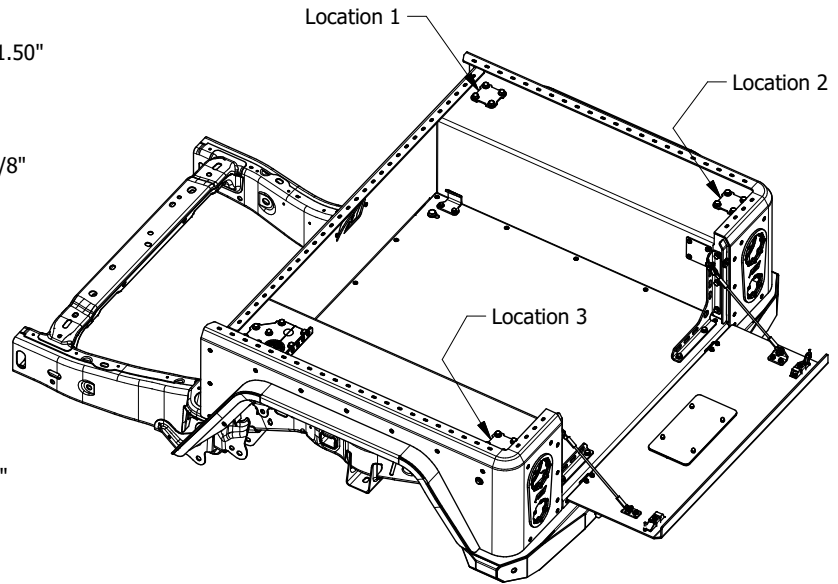

**TIGHTEN
FASTENERS**

USE BAG LABELED AS
1178-KIT11

MB1178 - Assembly JT Gladiator Bobbed Bed**FUEL FILLER ARRANGEMENTS**

This kit includes provisions for installing either a GASOLINE fuel filler or a DIESEL fuel filler with DEF filler tube & DEF cap. You will reuse and/or modify the factory fuel filler components for both fuel filler arrangements.

If you have a GASOLINE fuel vehicle, use the sections named "GASOLINE ARRANGEMENT". The 1178-KIT12 & 1178-KIT13 in the CONTENTS sections denotes GASOLINE compatible components as shown in RED. Components shown in BLACK are common to both GASOLINE or DIESEL & will be used for either arrangement.

If you have a DIESEL fuel vehicle, use the sections named "DIESEL ARRANGEMENT". The 1178-KIT12 & 1178-KIT13 in the CONTENTS sections denotes DIESEL compatible components as shown in GREEN. Components shown in BLACK are common to both GASOLINE or DIESEL & will be used for either arrangement.

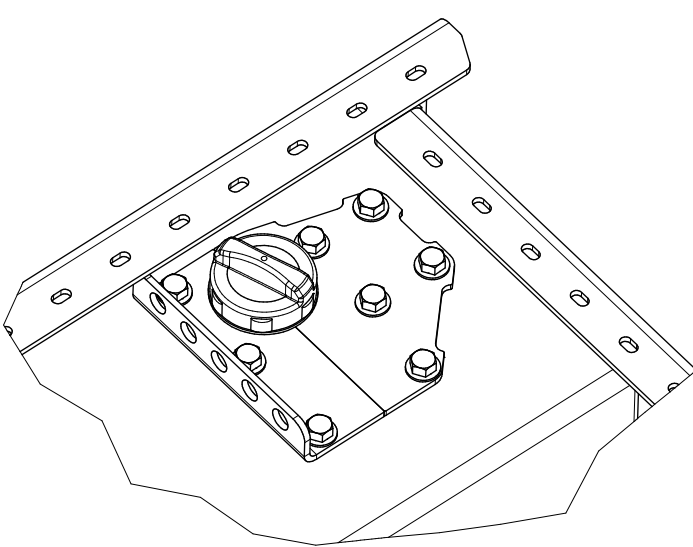
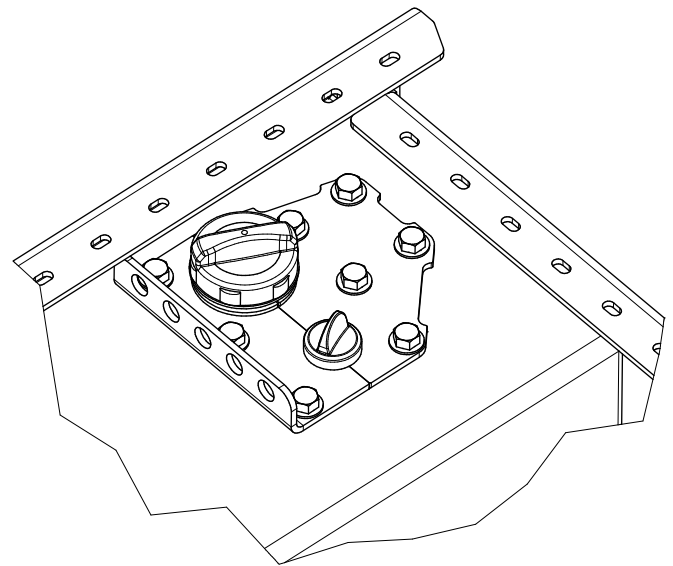
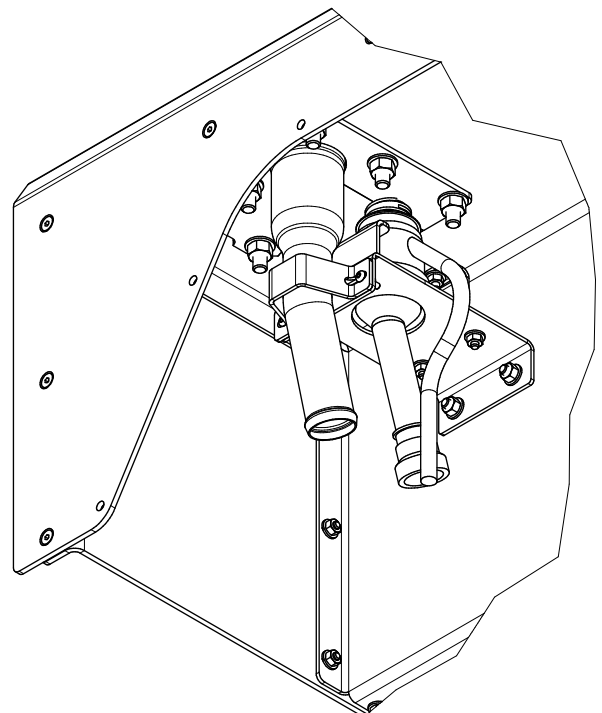
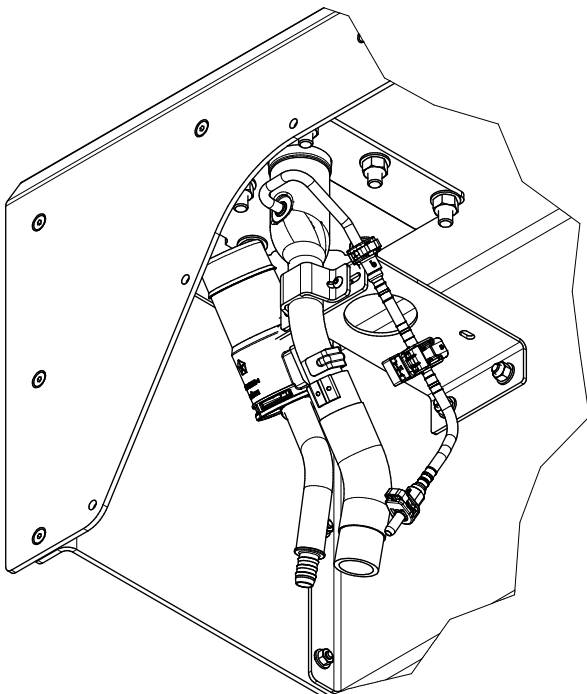
**GASOLINE ARRANGEMENT****DIESEL ARRANGEMENT**

MB1178 - Assembly JT Gladiator Bobbed Bed**GASOLINE ARRANGEMENT STEP 18
GAS FUEL FILLER MODIFICATION**

Disconnect the factory gasoline fuel filler from the factory filler hose. Cut off the brackets shown below. Ensure all cut edges are deburred & have no sharp edges.

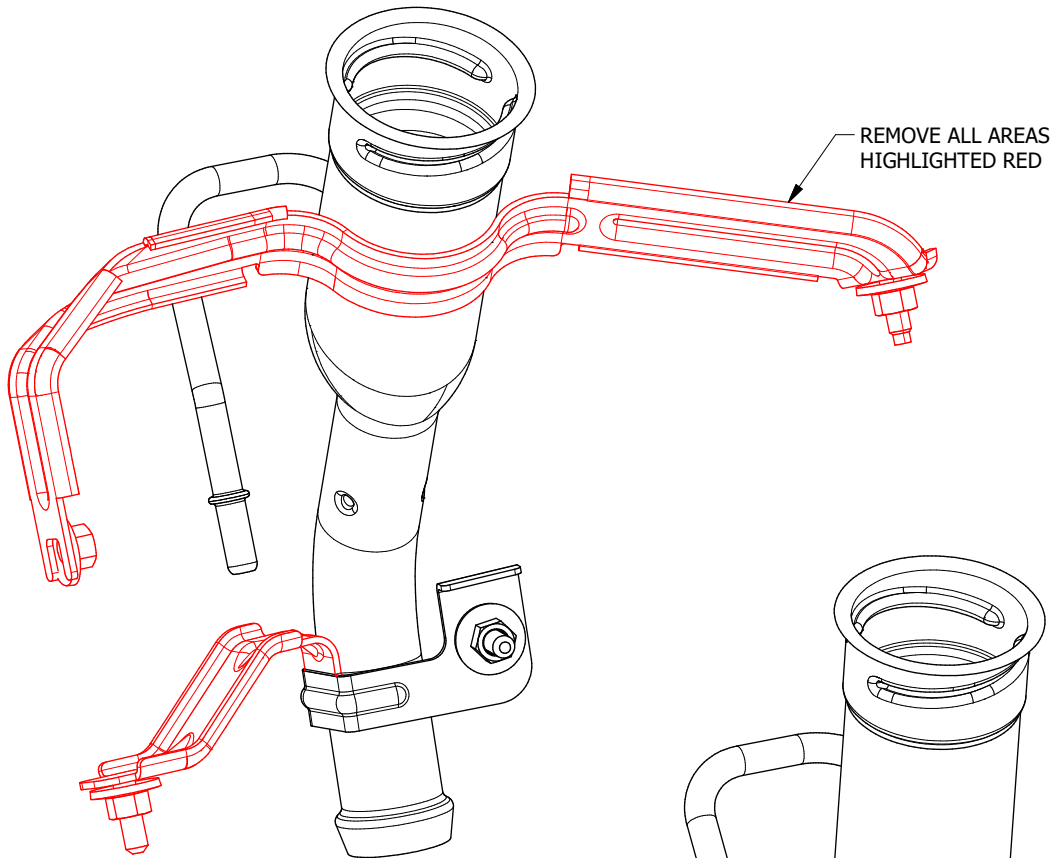
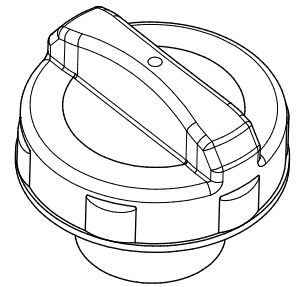
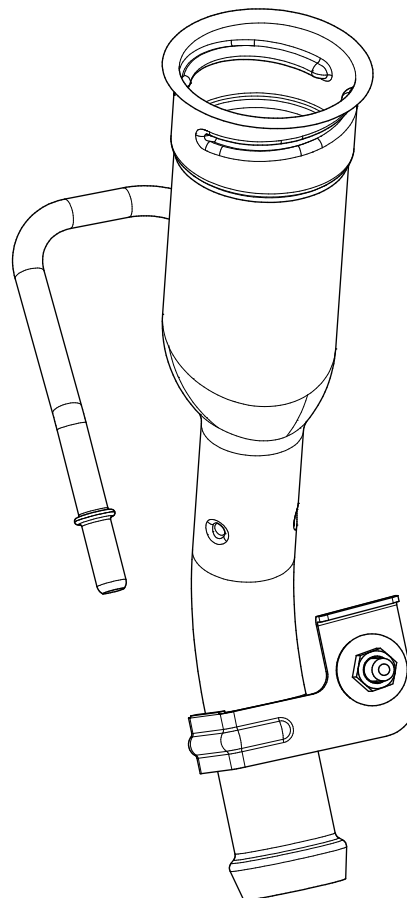
**BEFORE****FACTORY GAS CAP****AFTER**

MB1178 - Assembly JT Gladiator Bobbed Bed

GASOLINE ARRANGEMENT STEP 19

The fuel filler plates also serve as removable custom cage mounts. The plates are split in half both on the topside & bottom side. This is designed to support the modified factory fuel filler. The topside plates have a raised section welded to them. Place the raised section facing up. This provides the necessary support & spacing for the factory gas cap. The lower brackets mount inside the driver inner fender. The U-shaped clamp bracket supports the fuel filler neck.

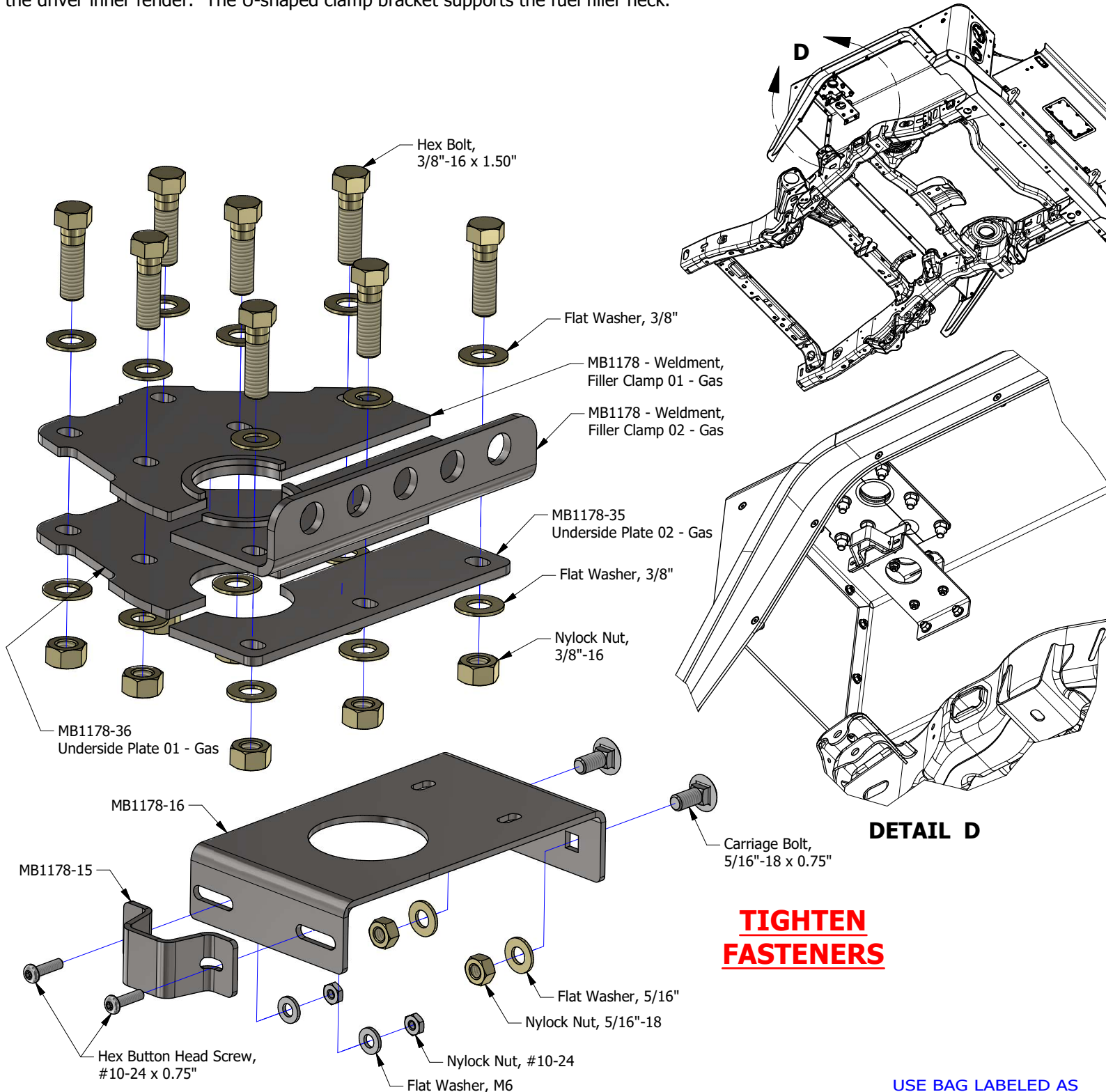

USE BAG LABELED AS
1178-KIT12
 USE BAG LABELED AS
1178-KIT13

MB1178 - Assembly JT Gladiator Bobbed Bed

GASOLINE ARRANGEMENT STEP 20

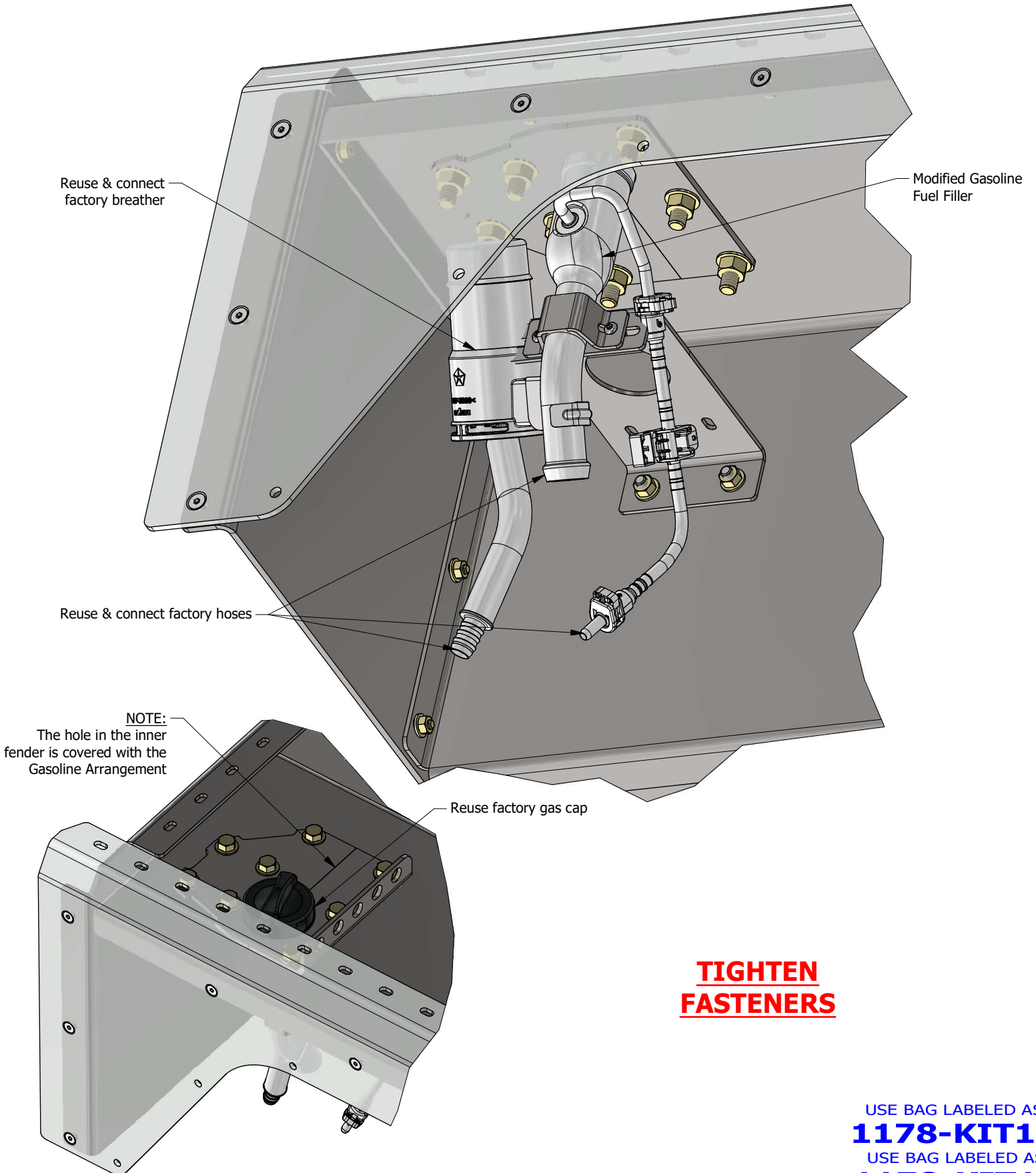

MB1178 - Assembly JT Gladiator Bobbed Bed**DIESEL ARRANGEMENT STEP 18
REUSE FACTORY DIESEL FUEL FILLER
& REUSE FACTORY DEF FILLER**

Disconnect the factory diesel fuel filler & the factory DEF filler from the factory filler hoses. No modification is needed.

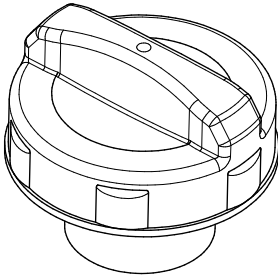
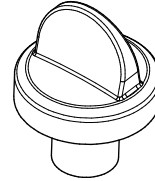
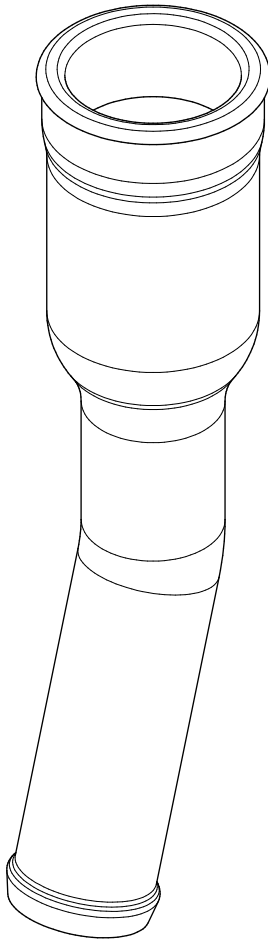
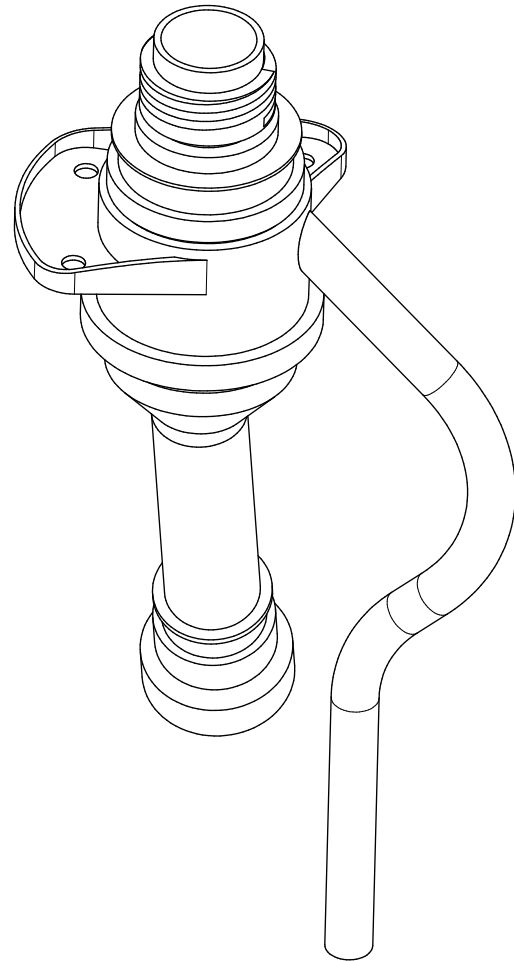
**FACTORY DIESEL CAP****FACTORY DEF CAP****FACTORY DIESEL FILLER****FACTORY DEF FILLER**

MB1178 - Assembly JT Gladiator Bobbed Bed

DIESEL ARRANGEMENT STEP 19

The fuel filler plates also serve as removable custom cage mounts. The plates are split in half both on the topside & bottom side. This is designed to support the factory fuel filler. The topside plates have a raised section welded to them. Place the raised section facing up. This provides the necessary support & spacing for the factory diesel cap. The lower brackets mount inside the driver inner fender. The U-shaped clamp bracket supports the fuel filler neck.

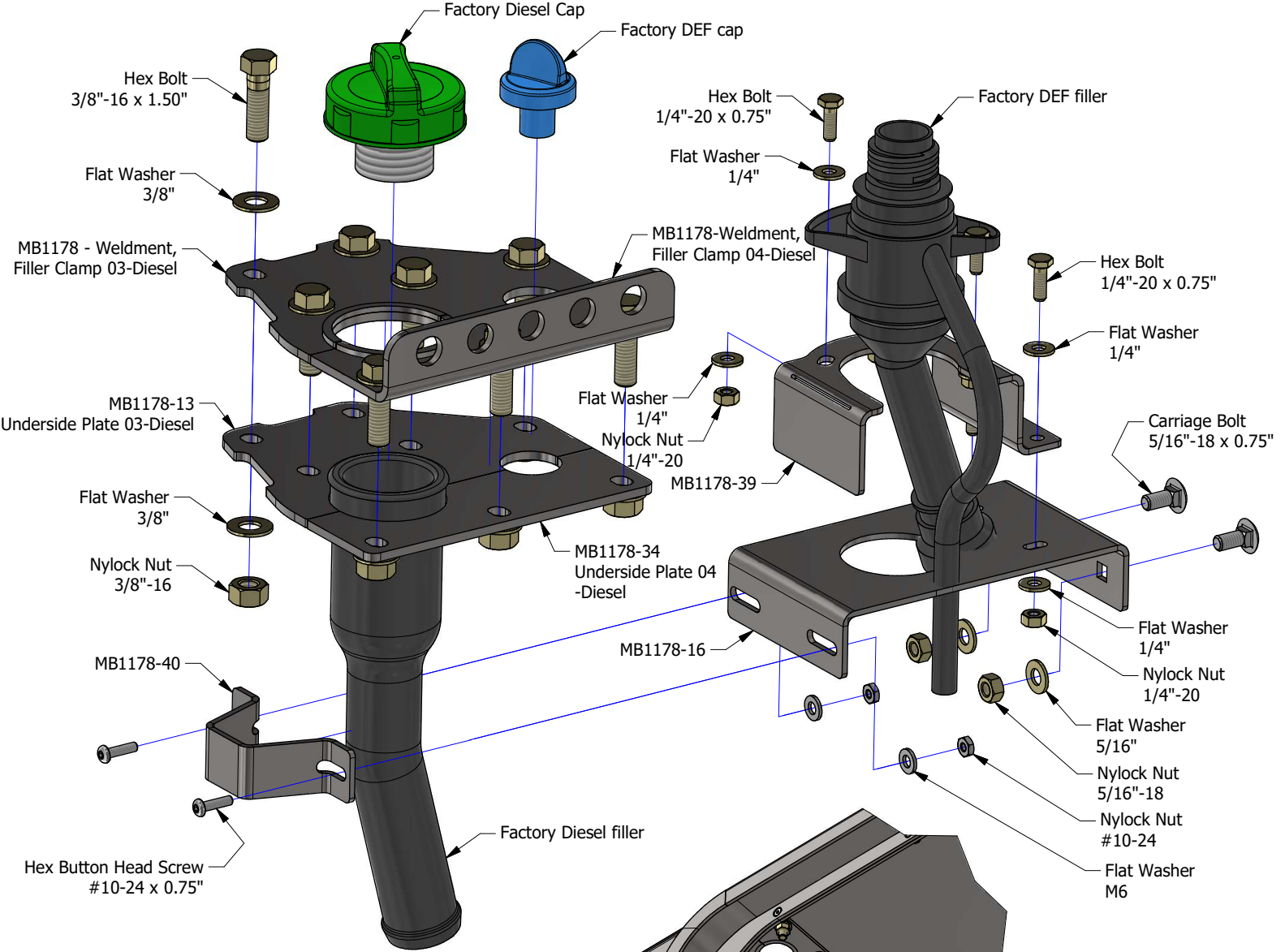

TIGHTEN FASTENERS

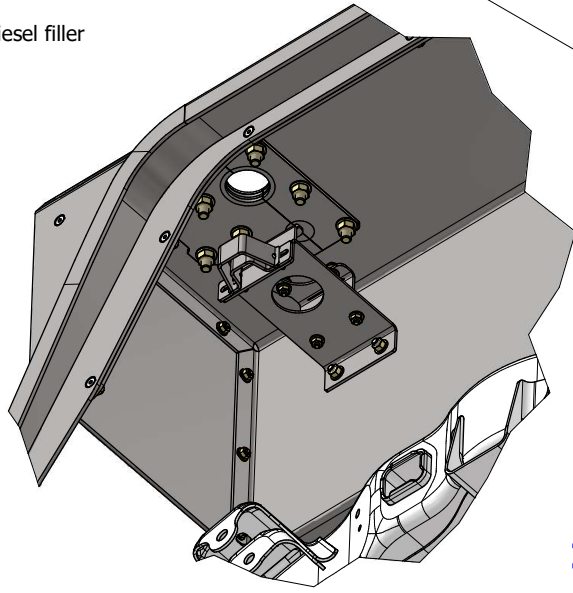
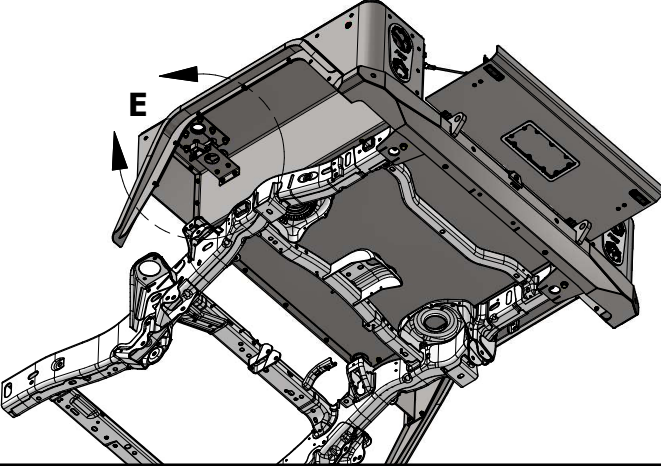

DETAIL E

USE BAG LABELED AS
1178-KIT12
USE BAG LABELED AS
1178-KIT13

MB1178 - Assembly JT Gladiator Bobbed Bed

DIESEL ARRANGEMENT STEP 20

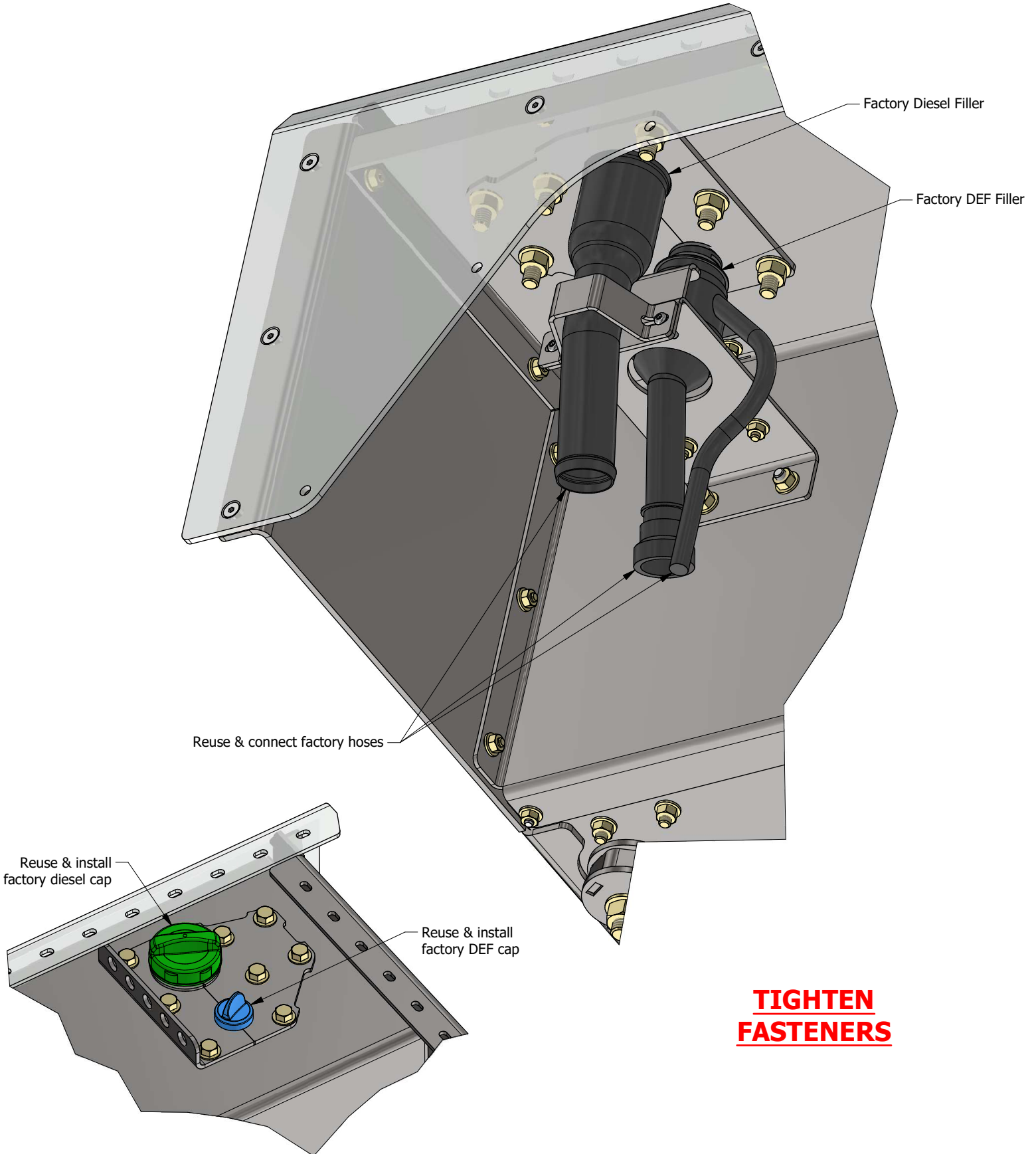

MB1178 - Assembly JT Gladiator Bobbed Bed

BED ASSEMBLY STEP 21

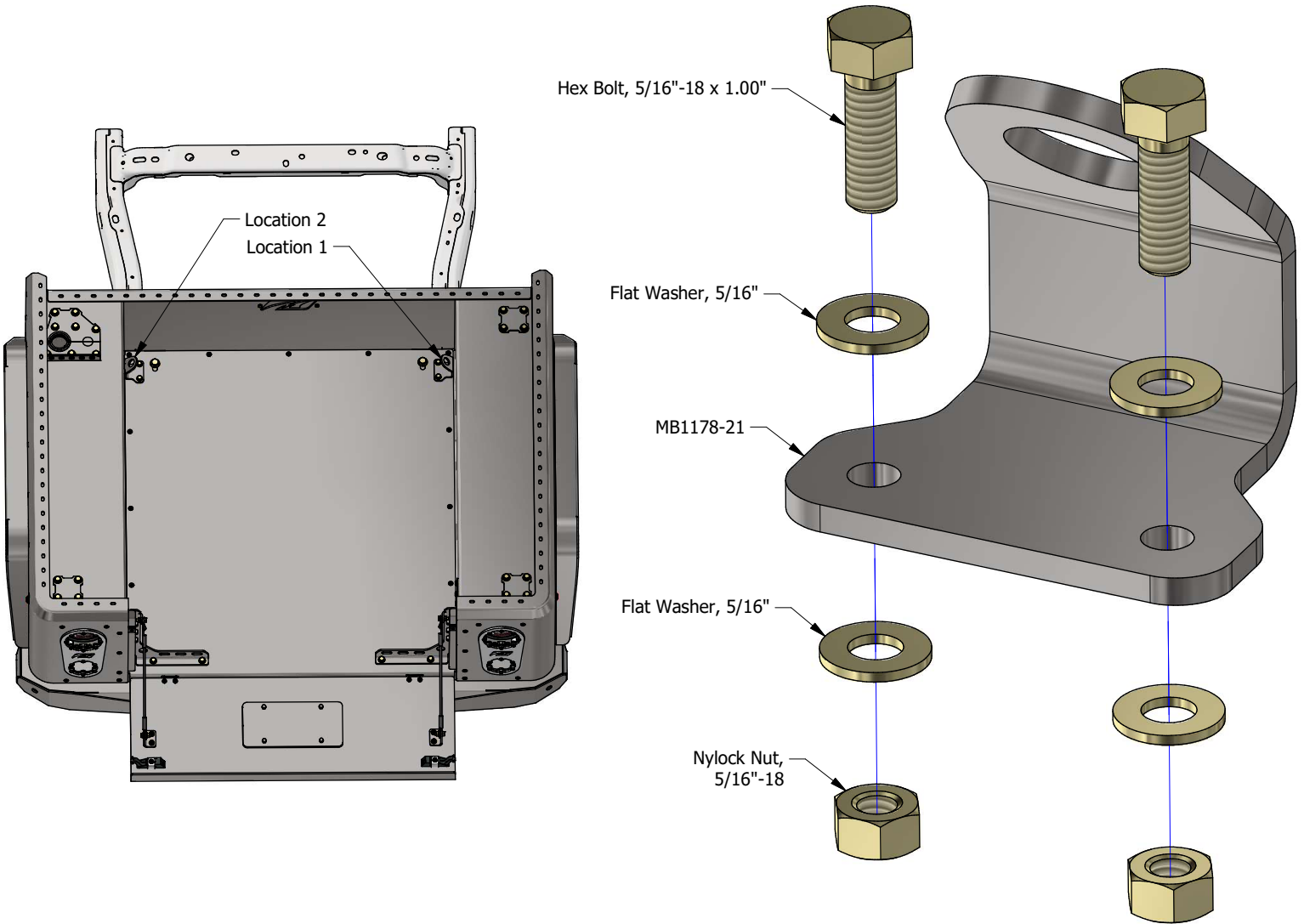

**FRONT TIE DOWN ASSEMBLY
2 LOCATIONS**

**TIGHTEN
FASTENERS**

USE BAG LABELED AS
1178-KIT14

MB1178 - Assembly JT Gladiator Bobbed Bed

BED ASSEMBLY STEP 22

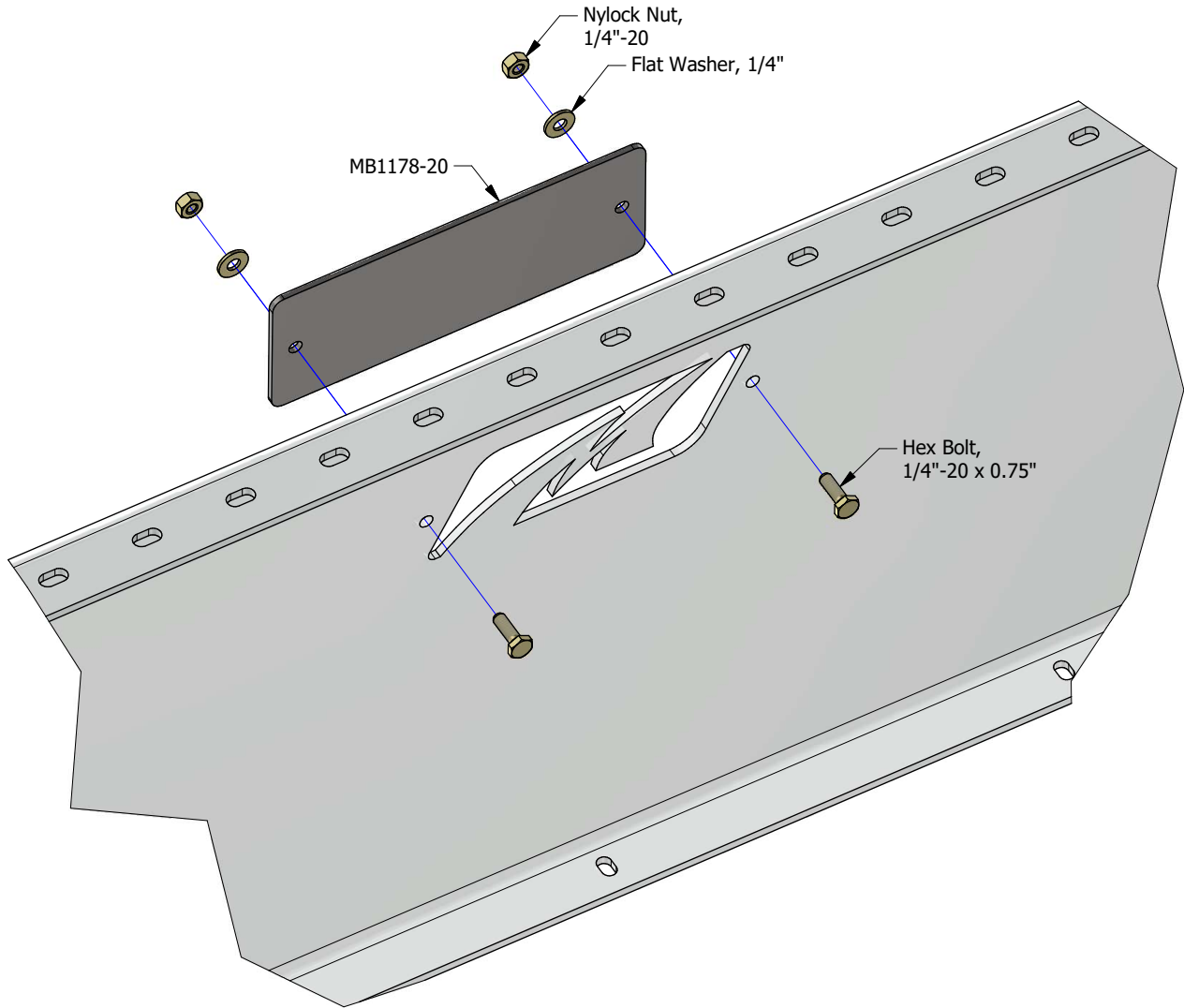

LOGO BACKING PLATE ASSEMBLY

TIGHTEN
FASTENERS

USE BAG LABELED AS
1178-KIT15

MB1178 - Assembly JT Gladiator Bobbed Bed

BED ASSEMBLY STEP 23

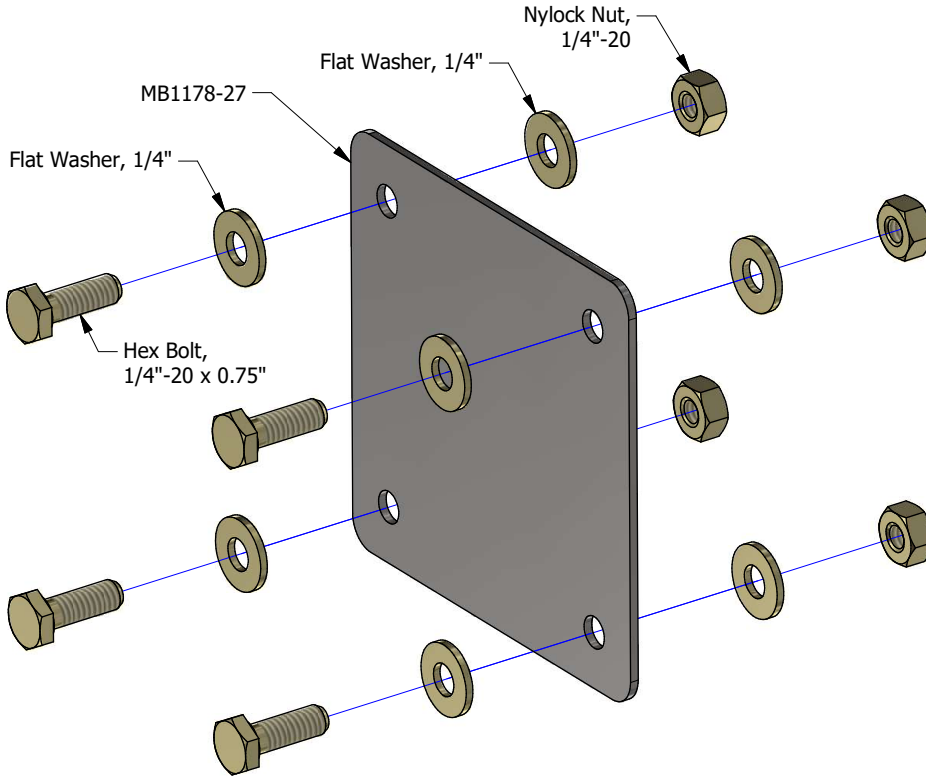

You can reuse the factory 120V receptacle from the bed of the Gladiator (if equipped). Substitute the receptacle in place of the cover plate MB1178-27 & use the supplied fasteners.

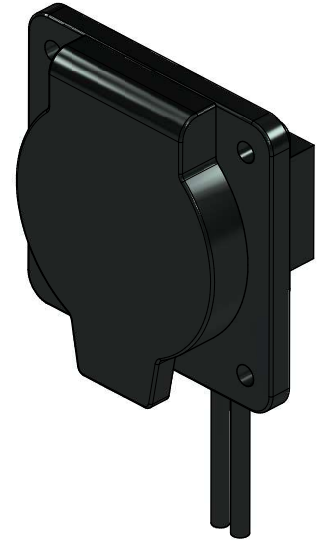

FACTORY RECEPTACLE

COVER PLATE ASSEMBLY

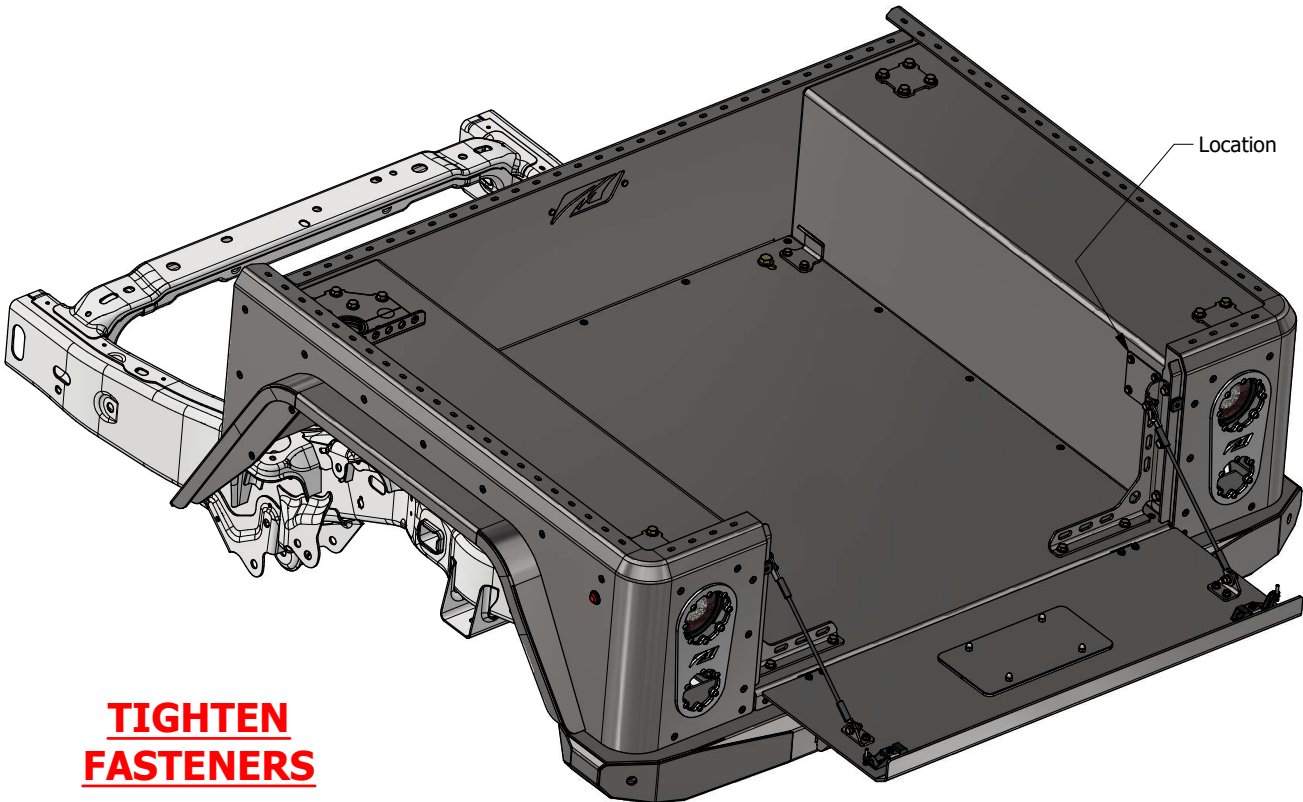

TIGHTEN
FASTENERS

USE BAG LABELED AS
1178-KIT16

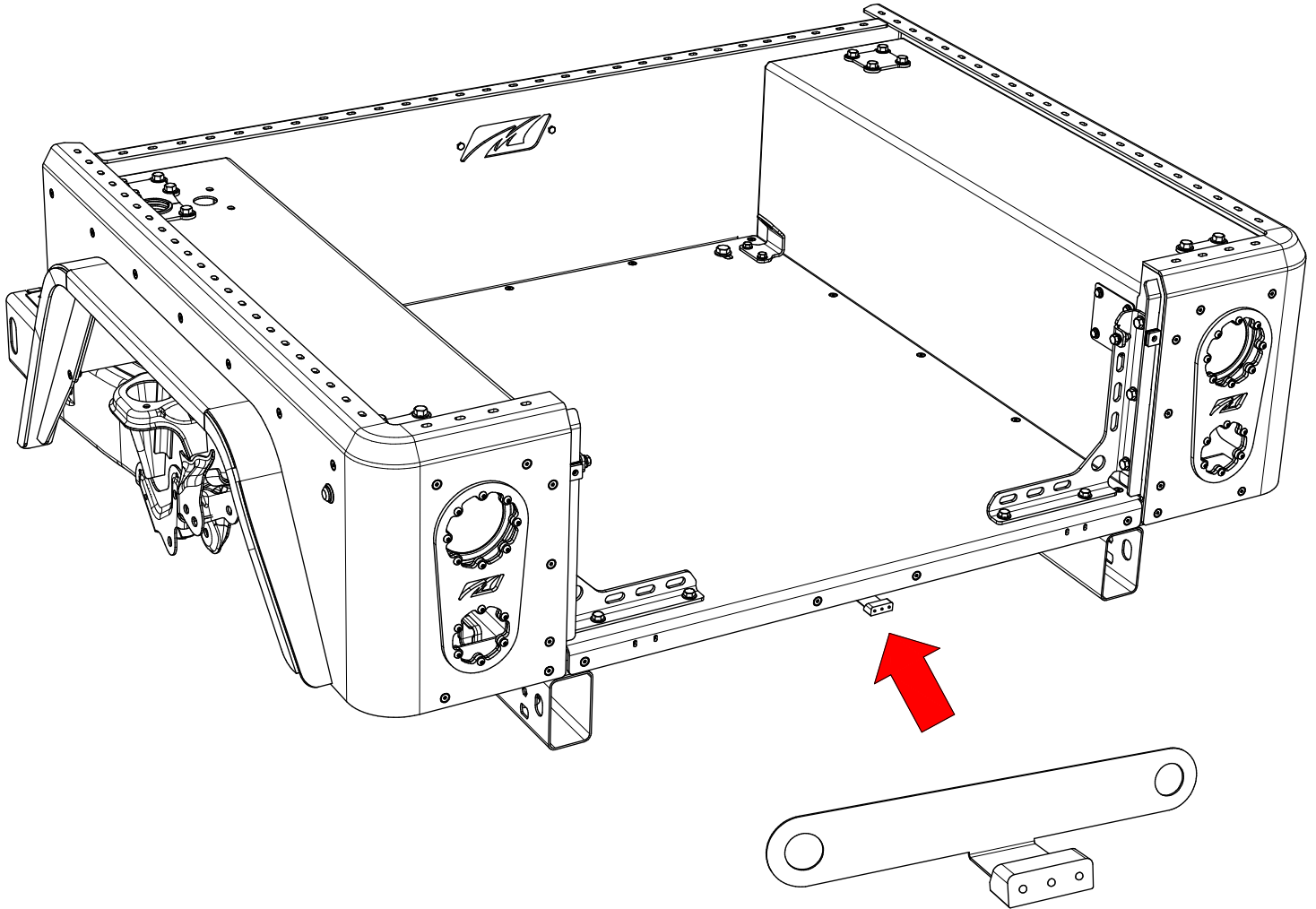
MB1178 - Assembly JT Gladiator Bobbed Bed**BED ASSEMBLY STEP 24****Light, License Plate**

The License Plate Light installs under & behind the back lip of the floor plate. Use the existing flat washers & nuts installed earlier to mount the light.

USE BAG LABELED AS
1178-KIT17

MB1178 - Assembly JT Gladiator Bobbed Bed**BED ASSEMBLY STEP 25**

Some jurisdictions may require Rear Side Marker Lights. If required in your area, determine your location needed, drill holes in the outer fenders & install the Side Marker Lights included with this kit.

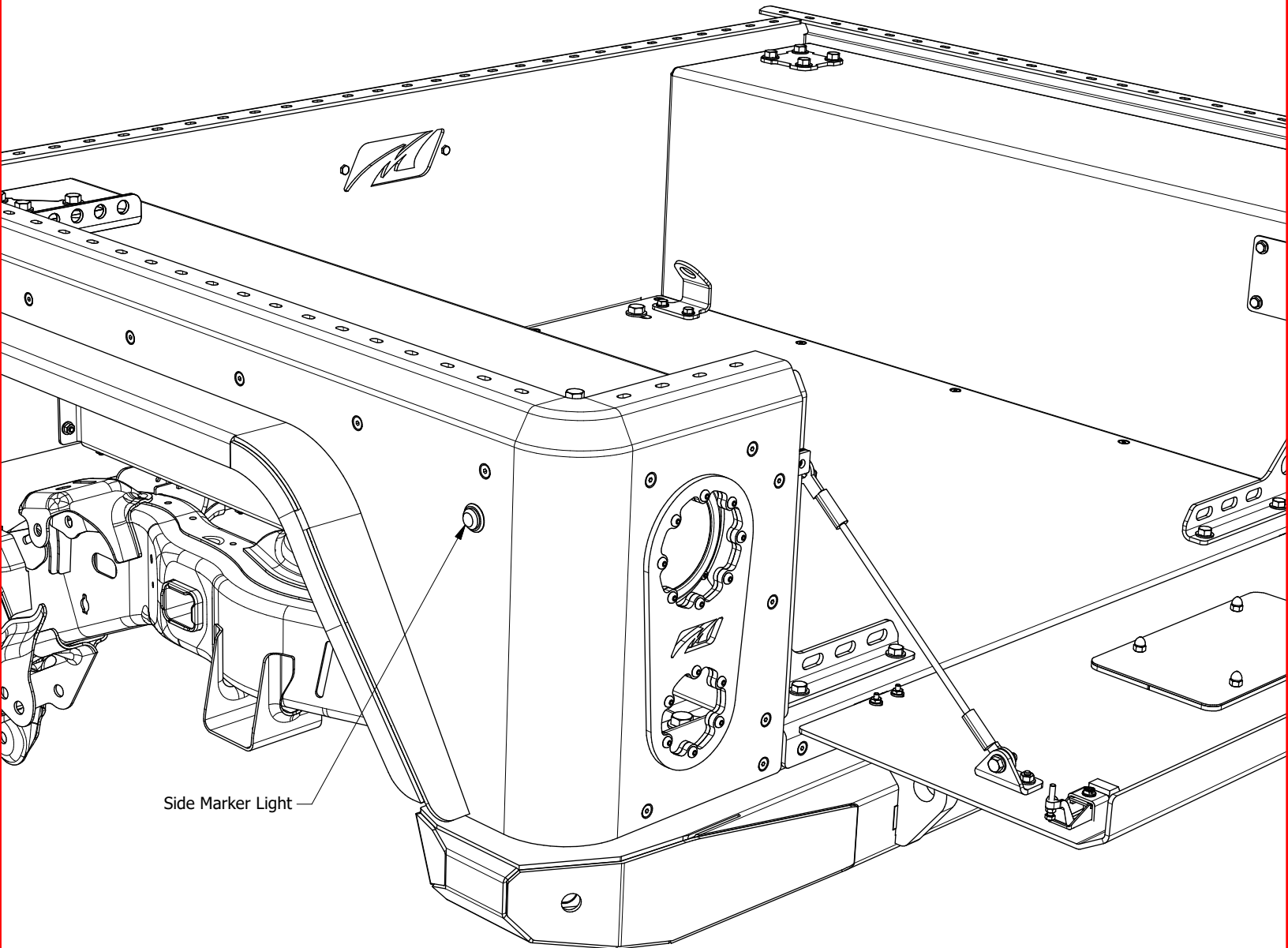

Side Marker Light

USE BAG LABELED AS
1178-KIT17

MB1178 - Assembly JT Gladiator Bobbed Bed

FENDER ASSEMBLY

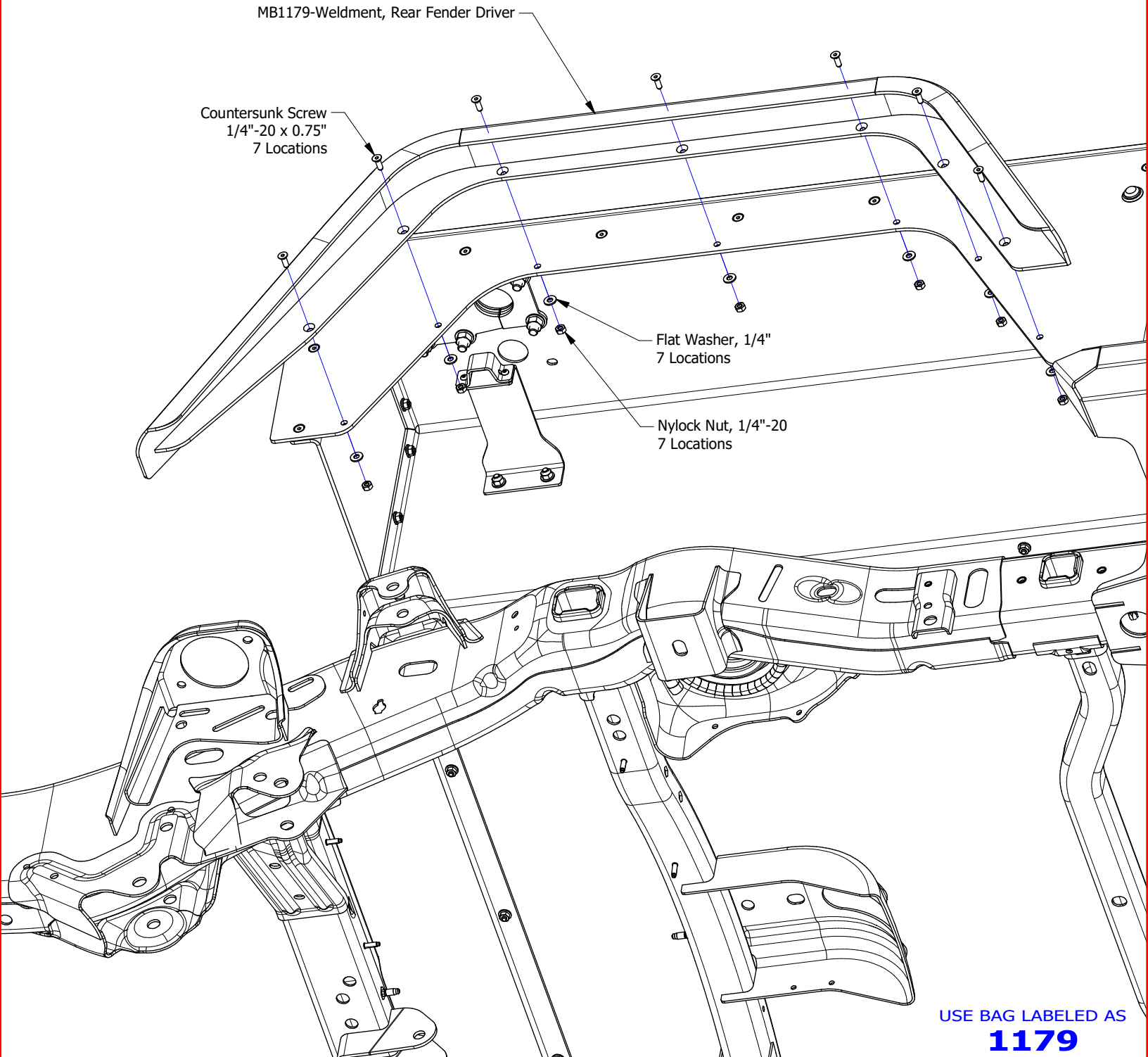

USE BAG LABELED AS
1179

MB1178 - Assembly JT Gladiator Bobbed Bed

WIRING FOR FACTORY NON-LED

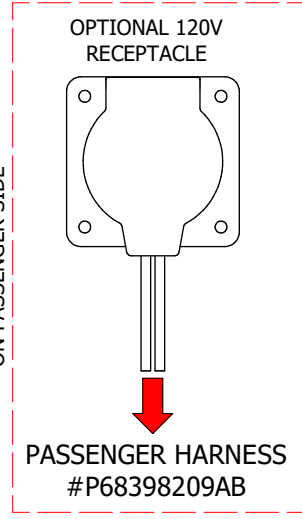
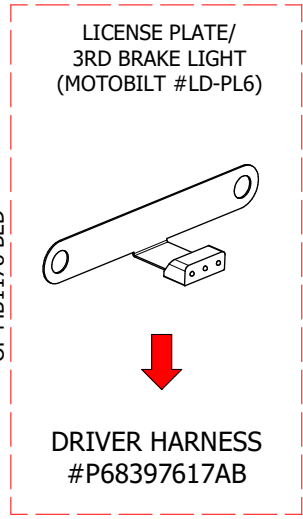
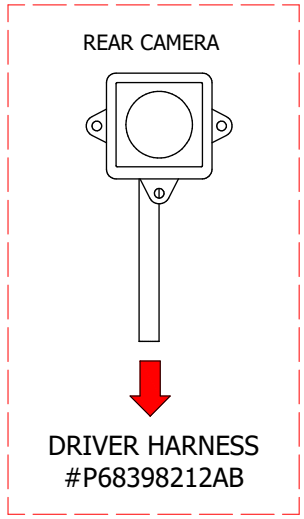
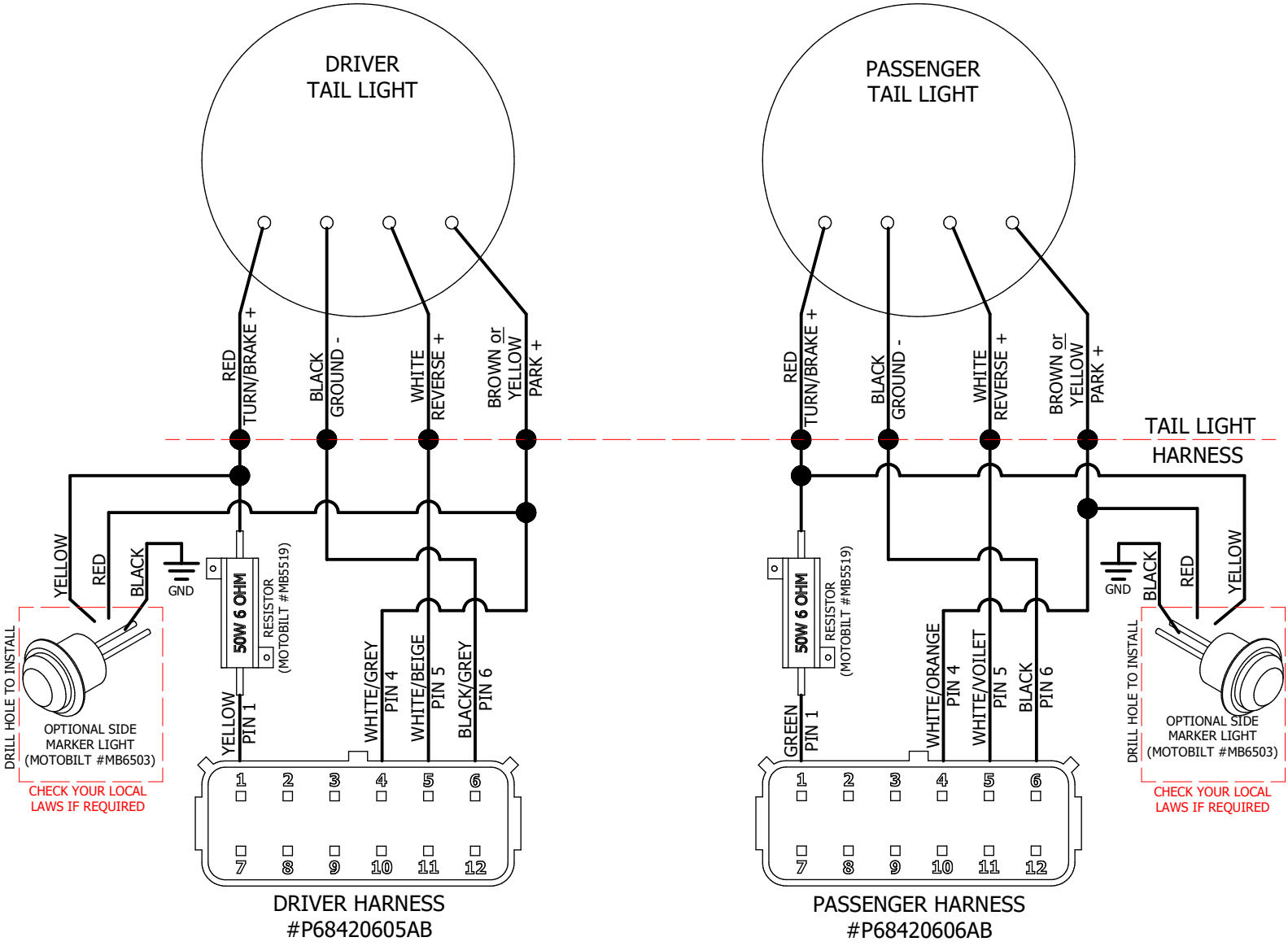

MB1178 - Assembly JT Gladiator Bobbed Bed

WIRING FOR FACTORY LED

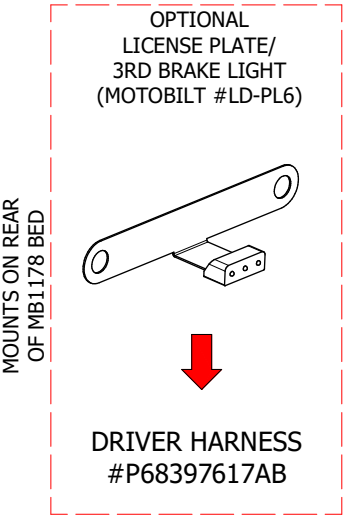
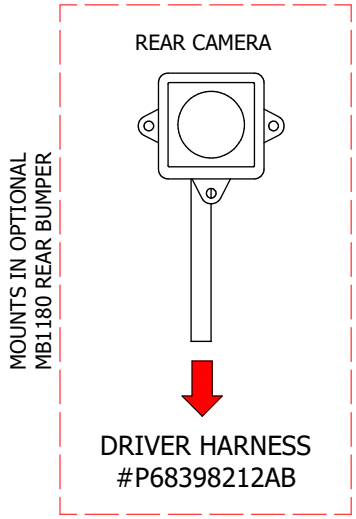
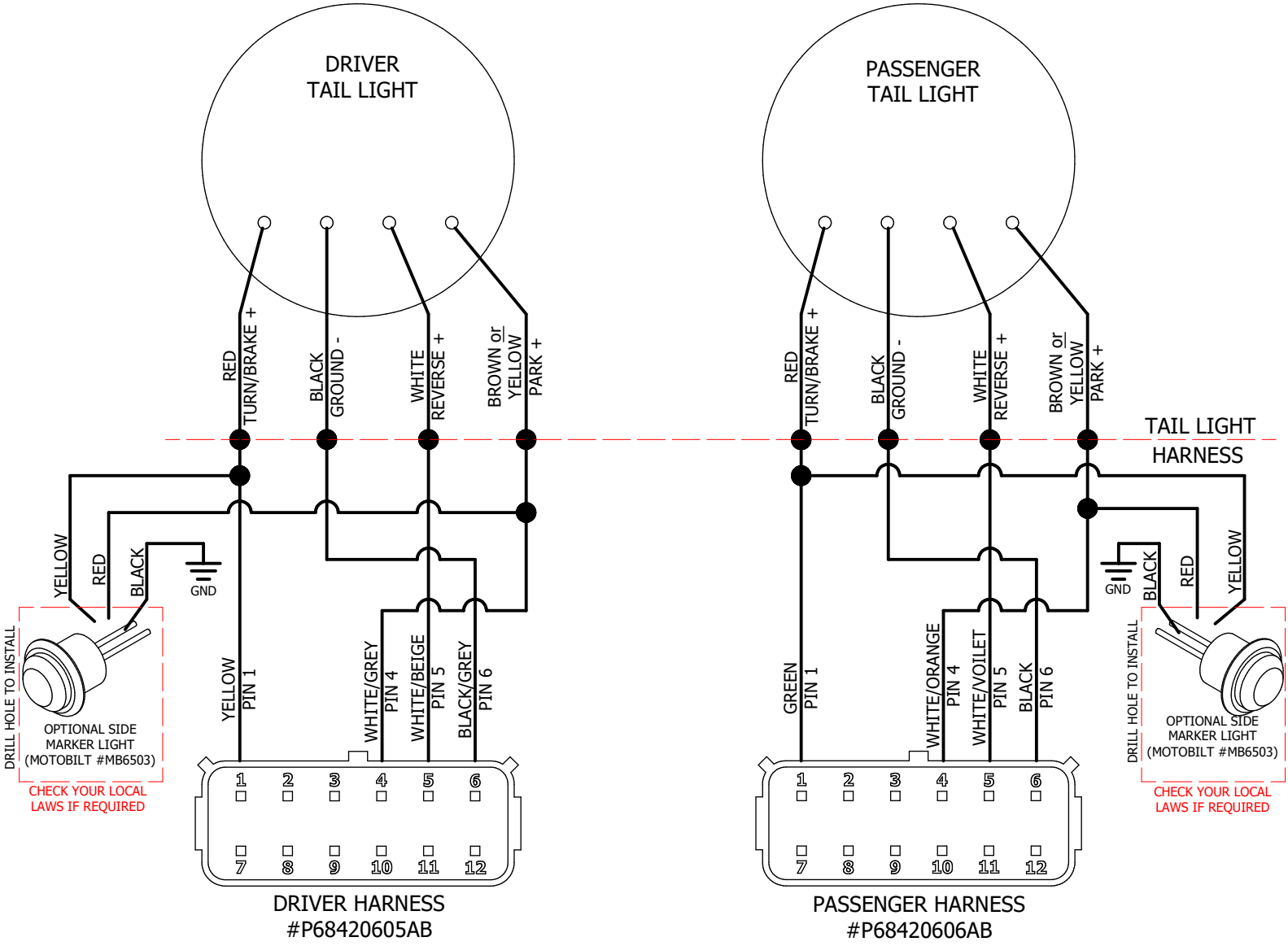

CHECK YOUR LOCAL LAWS IF REQUIRED

