

JLU FRAME MOUNTED ROCK RAILS

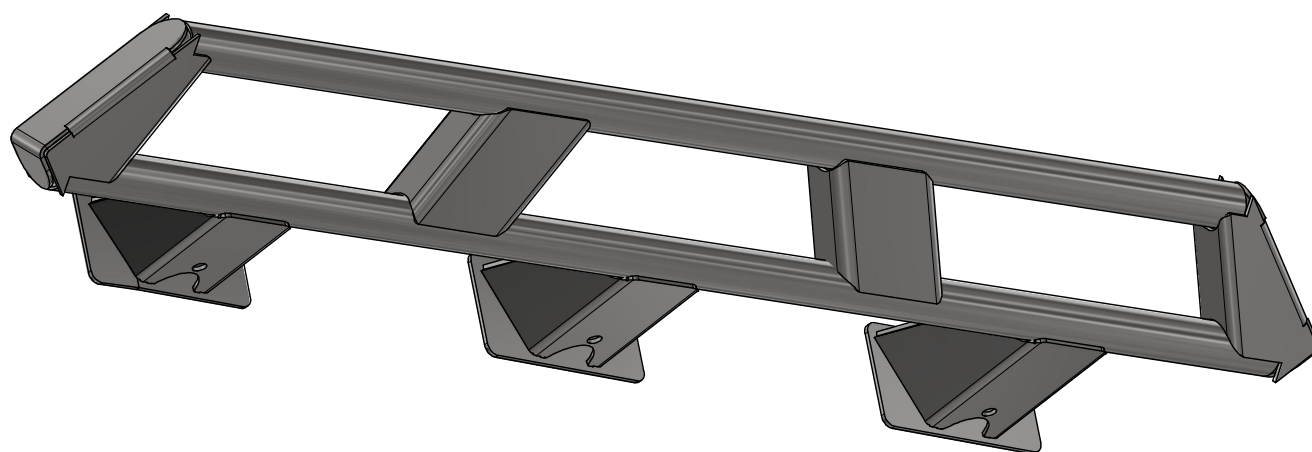
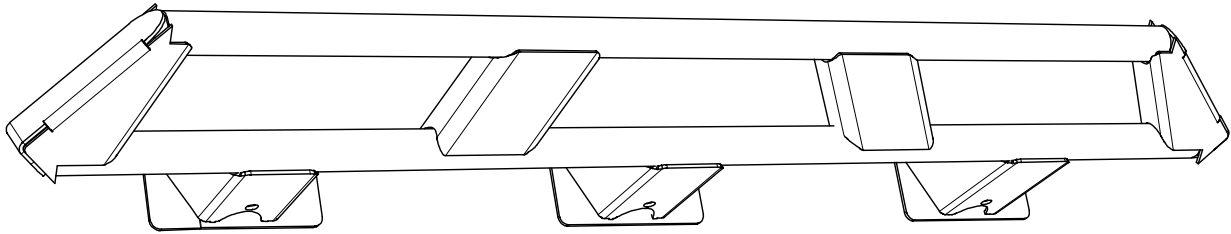
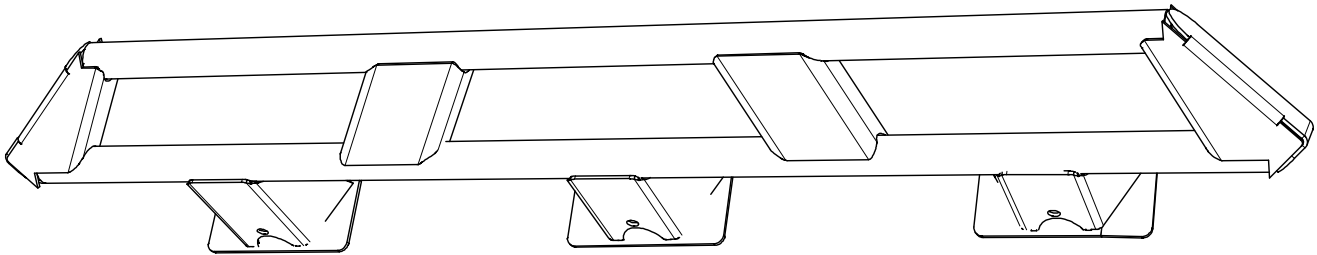

ASSEMBLY INSTRUCTIONS

MB1158 - Assembly Instructions JLU Frame Mounted Rock Rails**KIT COMPONENTS****MB1158 - DRIVER**
Qty: 1**MB1158 - PASSENGER**
Qty: 1

MB1158 - Assembly Instructions JLU Frame Mounted Rock Rails**POSITIONING**

POSITION THE SLIDER SO THAT THE LEADING EDGE OF THE FORWARD MOST MOUNTING PLATE IS 3" FROM THE REAR MOST POINT OF THE BODY MOUNT.

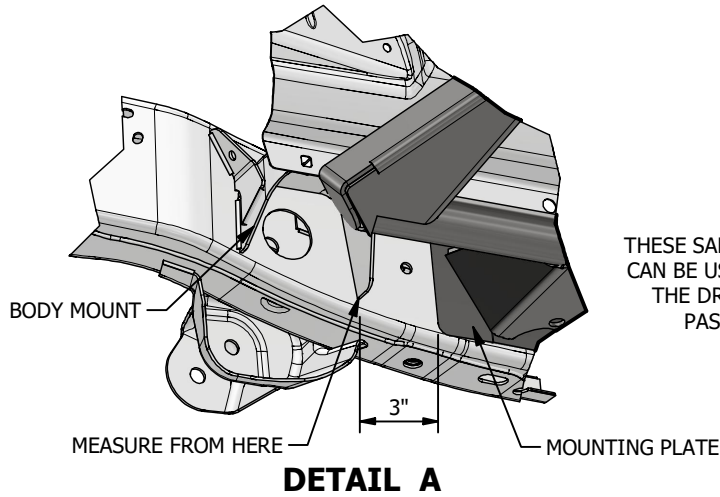

POSITION THE SLIDE SO THAT THE BOTTOM EDGE OF THE EACH MOUNTING PLATE IS AS LOW AS IT CAN GO ON THE FRAME WHILE STILL CONTACTING THE FRAME.

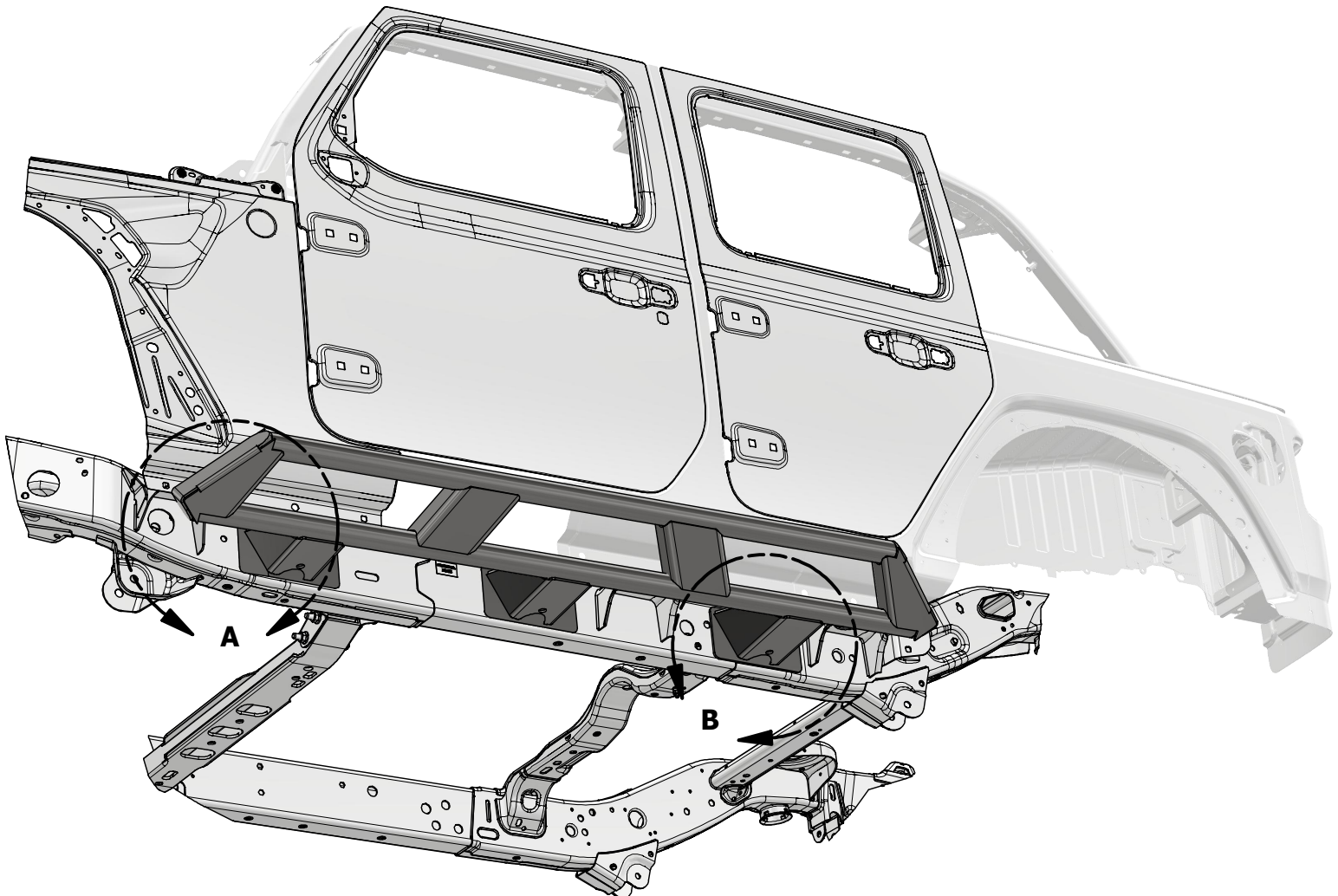
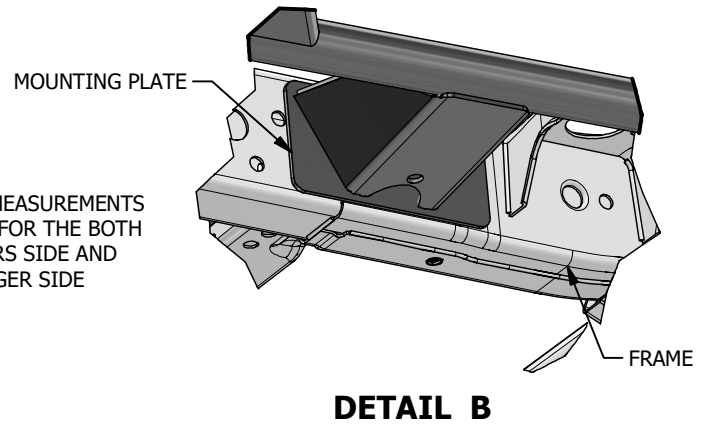

MB1158 - Assembly Instructions JLU Frame Mounted Rock Rails

WELDING

1. DISCONNECT THE NEGATIVE TERMINAL OF THE BATTERY
2. MARK THE AREAS WHERE THE MOUNTING PLATES WILL BE WELDED TO THE FRAME. REMOVE THE ROCK SLIDERS AND CLEAN THE AREA OF ANY PAINT OR DEBRIS.
3. REPOSITION THE ROCK SLIDERS AND TACK INTO PLACE.
4. CONFIRM THE POSITION OF THE ROCK SLIDER ON THE FRAME
5. WELD THE CIRCUMFERENCE OF EACH MOUNTING PLATE TO THE FRAME.
6. PAINT OR PROTECT THE ROCK SLIDER, FRAME, AND WELDS FROM CORROSION.

